

REV.NO.	REVISION DESCRIPTION	DRAWN / DATE	REVIEWED / DATE	APPROVED / DATE
	Previous versions omitted			
△	Correct switch type error	KYJ/20230308		
△	Range display changed ...	KCH/20241220	JCS/20241220	KTJ/20241220

Specifications

Model		<input type="checkbox"/> YT-870M	<input type="checkbox"/> YT-870P	<input type="checkbox"/> YT-870D	
Limit Switch	Switch Type	Mechanical Switch, 2 x SPDT	Inductive Proximity Sensor x 2		
	Model No. & Manufacturer	SS-5GL (Omron)	<input type="checkbox"/> <Standard> PSN17-5DNU (Autonics, NPN type)	<input type="checkbox"/> <Option> NJ2-V3-N (P&F, NC type)	
	Switch Rating	AC	250 V 3 A 125 V 5 A	-	125 or 250 V 10A
		DC	250 V 0.2 A, 125 V 0.4 A, 30 V 4 A, 14 V 5 A, 8 V 5 A	12 to 24 V	8 V 125 V 0.5 A, 250 V 0.25 A 30 V 10 A, 14 V 10 A, 8 V 10 A
Terminal		8 Point	8 Point	12 Point	
<input type="checkbox"/> Sptm In	Connection Type	2 wire			
	External Load Resistance	Rext ≤ (Vs-9) / 20 mA, 750 ohms @Vs = 24 V			
	Supply Voltage	Vs : 9 to 28 V DC			
Ingress Protection		Type 4, 4X (CSA), IP 67			
Explosion Protection		<input type="checkbox"/> KCs : Ex d IIC T6, Ex tb IIIC T85°C ATEX : II 2G Ex db IIC T6 Gb, II 2D Ex tb IIIC T85°C Db <input type="checkbox"/> IECEx, CCC : Ex db IIC T6 Gb, Ex tb IIIC T85°C Db CSA : Ex db IIC T6; Cl I, Zn 1, AEx db IIC T6; Cl II, Div I, Grps E, F and G; Zn 21, AEx tb IIIC T85°C <input type="checkbox"/> CCC : Ex db IIC T6 Gb, Ex tb IIIC T85°C Db			
Ambient Temp.		-20 to 60 °C(-4 to 140 °F)			
Conduit Entry		<input type="checkbox"/> 2-3/4 NPT	<input type="checkbox"/> 2-G 3/4	<input type="checkbox"/> 2-M20x1.5P <input type="checkbox"/> 2-1/2 NPT	
Mounting Bracket Standard		NAMUR VDI/VDE 3845, ISO 5211			
Housing Material		Aluminum			
Painting		Polyester powder coating			
Weight		1.5 kg (3.3 lb)			

No.	Part name	Material	Q'ty	Remarks
1	Indicator	ABS	1	
2	Indicator cover	PC(Poly carbonate)	1	
3	Base cover	ALDC12	1	
4	Base body	ALDC12	1	
5	Main shaft	STS303	1	
6	Name plate	STS304P	1	

SURFACE TEXTURE		PRODUCT NAME		PROJECT NAME	
FINISH TREATMENT		Limit switch box		-	
MATERIAL		MODEL		rotork® Rotork YTC Limited GMP0-SI, KOREA	
OTHERWISE NOTE		PROJECTION		TITLE	
GENERAL TOLERANCE		3rd		Standard	
		SCALE		DRAWING NO.	
		1 / 2.5		YTC-870-1	
		QUANTITY		REV.	
		1		6	
		SHEET No.			
		1 / 1			

Earth (External, Internal)

1. Minimum Size Wire 1mm² or 18AWG.
2. M4x5L, 0.7P Round Head Screw
3. M4 Spring washer

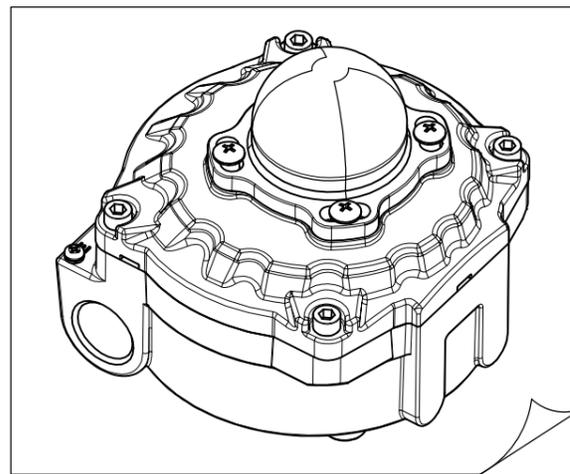
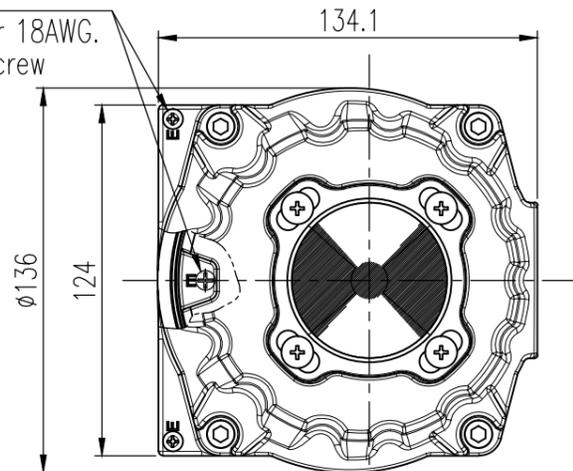

Indicator cover(PC)

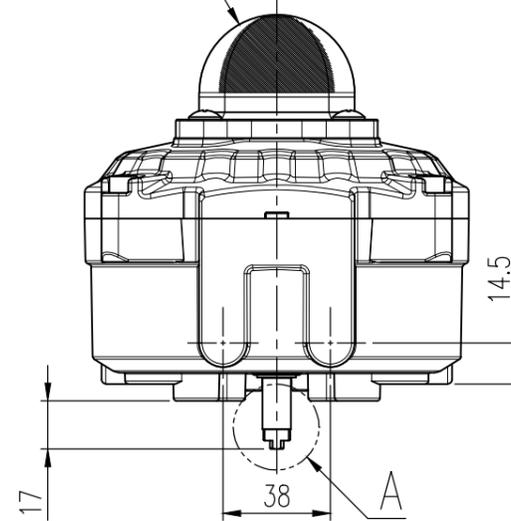
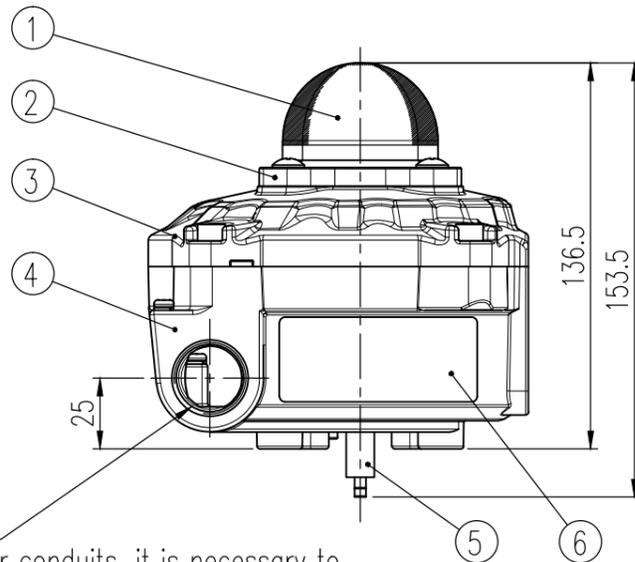

- 2-Conduit, 3/4 NPT, G 3/4, M20x1.5P, 1/2 NPT

During connecting cable or conduits, it is necessary to follow flame-proof certified procedure or flame-proof certified cable gland or flexible coupling.

