

YT-400S



YT-400D



YT-405S



YT-405D



YT-430S



YT-430D



YT-435S



YT-435D

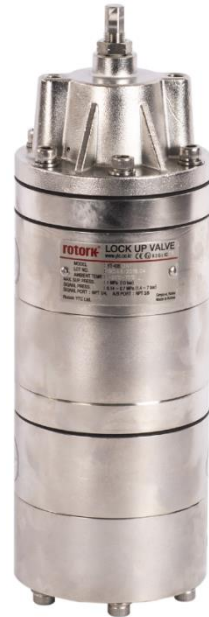

Contents

1	Introduction	3
1.1	General Information for the users	3
1.2	Manufacturer Warranty	3
2	Product Description	4
2.1	General	4
2.2	Main Features and Functions	4
2.3	Label Description	4
2.4	Product Code	6
2.5	Product Specification	6
2.6	Product Dimension	7
2.6.1	YT-400 / 405	7
2.6.2	YT-430 / 435	7
2.7	Operation Logic	8
2.8	Section drawings	9
2.8.1	YT-400 / 405	9
2.8.2	YT-430 / 435	10
3	Installation	11
3.1	Safety	11
3.2	Installation	12
3.3	Installation Example	13
4	Maintenance	14
4.1	Replacement of Parts (Repair kit)	14
4.2	Replacing Upper diaphragm ass'y	14
5	Trouble-Shooting	15

1 Introduction

1.1 General Information for the users

Thank you for purchasing Rotork YTC Limited products. Each product has been fully inspected after its production to offer you the highest quality and reliable performance. Please read the product manual carefully prior to installing and commissioning the product.

- Installation, commissioning, and maintenance of the product may only be performed by trained specialist personnel who have been authorized by the plant operator accordingly.
- The manual should be provided to the end-user.
- The manual can be altered or revised without any prior notice. Any changes in product's specification, design, and/or any components may not be printed immediately but until the following revision of the manual.
- The manual should not be duplicated or reproduced for any purpose without prior approval from Rotork YTC Limited, Gimpo-si, South Korea.
- In case of any other problems that are not stated in this manual, please make immediate contact to Rotork YTC Limited.

1.2 Manufacturer Warranty

- For the safety, it is important to follow the instructions in the manual. Manufacturer will not be responsible for any damages caused by user's negligence.
- Any modifications or repairs to the product may only be performed if expressed in this manual. Injuries and physical damages caused by customer's modifying or repairing the product without a prior consultation with Rotork YTC Limited will not be compensated. If any alterations or modifications are necessary, please contact Rotork YTC Limited directly.
- Standard type with NBR rubber (ambient temperature range option 1) is subject to damage by ozone. If you suspect that ozone may be present at the site or if supplied air is likely to contain ozone, select a high temperature version (ambient temperature range option 2) or a low temperature version (ambient temperature range option 3) with SILICONE rubber.
- The warranty period for the product is (12) months from the date of shipment unless otherwise stated. Customers can extend the warranty period by an additional (12) months by registering the product's serial number or lot number, customer information, and installation address on the warranty extension application site Product Registration (<https://www.rotork.com/en/service/product-registration>).
- Manufacturer warranty will not cover products that have been subjected to abuse, accidents, alterations, modifications, tampering, negligence, misuse, faulty installation, lack of reasonable care, repair or service in any way that is not contemplated in the documentation for the product, or if the model or serial number has been altered, tampered with, defaced or removed; damages that occurs in shipment, due to act of God, failure due to power surge, or cosmetic damage. Improper or incorrectly performed maintenance will void this limited warranty.

- For detailed warranty information, please contact the corresponding local Rotork YTC Limited office or main office in South Korea.

2 Product Description

2.1 General

The lock-up valve detects the plant's main pneumatic pressure as a signal pressure, and when the signal pressure drops below the set pressure, it blocks the flow path inside the lock-up valve to completely block the flow of pneumatic pressure. For general use, it is installed on the control valve, and when the main pneumatic pressure from the plant compressor is lower than the required pressure due to power failure or pipe breakage. It basically senses and blocks the flow path between the actuator and the positioner to maintain the current valve opening.

2.2 Main Features and Functions

- It can be installed using only piping without a separate bracket.
- Hysteresis is below 0.01 MPa.
- Built-in 80 mesh screen prevents foreign matter from entering and prevents malfunction.
- Highly corrosion-resistant polyester powder coated aluminum body or stainless steel body for high durability in various environments.

2.3 Label Description

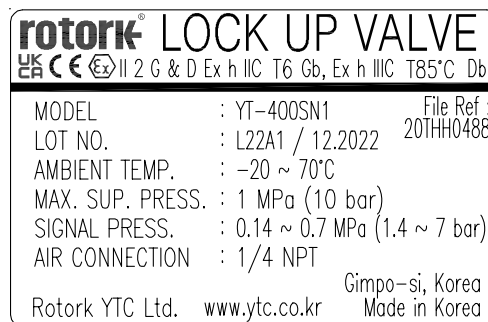

Fig. L-1: YT-400 (UKEX, ATEX)

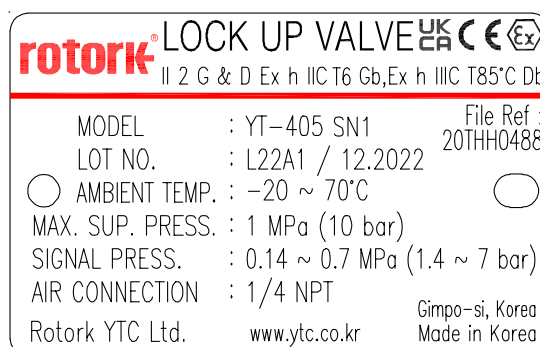

Fig. L-3: YT-405 (UKEX, ATEX)

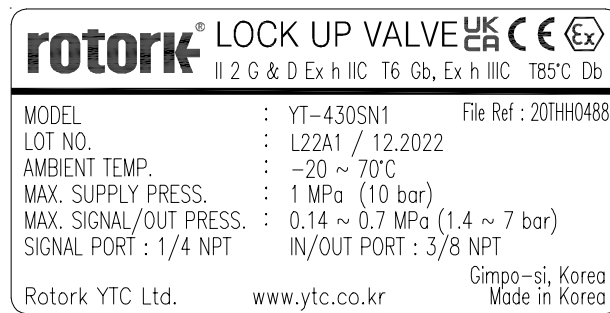

Fig. L-5: YT-430 (UKEX, ATEX)

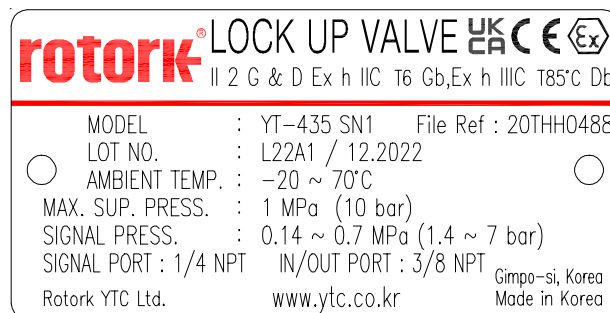

Fig. L-7: YT-435 (UKEX, ATEX)

- MODEL : Indicates the model number and additional symbols.
- LOT NO. : Indicates unique lot number.
- MONTH.YEAR : Indicates manufactured month and year.
- AMBIENT TEMP. : Indicates the allowable ambient temperature.
- MAX. SUPPLY : Indicates max. supply air pressure level.
- SIGNAL PRESSURE : Indicates the signal pressure range.
- AIR CONNECTION : Indicates connection thread type.

2.4 Product Code

YT-400 / 405 / 430 / 435 1 2 3

1	Acting type	S : Single acting
		D : Double acting
2	Air Connection type	P : Rc : N/A for YT-405 / 430 / 435
		N : NPT
3	Ambient Temperature	1 : -20 to 70 °C (-4 to 158 °F)
		2 : -20 to 120 °C (-4 to 248 °F)
		3 : -40 to 70 °C (-40 to 158 °F)
		4 : -50 to 70 °C (-58 to 158 °F)

2.5 Product Specification

Model		YT-400	YT-405	YT-430	YT-435
Max. Supply Pressure		Max. 1 MPa (10 bar)			
Signal Pressure Setting Range		0.14 to 0.7 MPa (1.4 to 7 bar)			
Hysteresis		Below 0.01 MPa (0.1 bar)			
Flow Capacity (CV)		0.9		1.8	
Input / Output Connection		Rc 1/4 or 1/4 NPT	1/4 NPT	3/8 NPT	
Signal Connection		Rc 1/4 or 1/4 NPT	1/4 NPT	1/4 NPT	
Ambient Temperature	Standard	-20 to 70 °C (-4 to 158 °F)			
	High	-20 to 120 °C (-4 to 248 °F)			
	Low	-40 to 70 °C (-40 to 158 °F)			
	Arctic	-50 to 70 °C (-58 to 158 °F)			
Housing Material		Aluminum	Stainless Steel 316	Aluminum	Stainless Steel 316
Weight	Single	0.47 kg (1.1 lb)	1.3 kg (2.2 lb)	1.5 kg (3.3 lb)	3.3 kg (7.3 lb)
	Double	0.66 kg (1.5 lb)	1.5 kg (3.3 lb)	2.7 kg (6 lb)	5.8 kg (12.8 lb)



Tested under ambient temperature of 20 °C, absolute pressure of 760 mmHg, and humidity of 65 %.

Please contact Rotork YTC Limited for detailed testing specification.

2.6 Product Dimension

2.6.1 YT-400 / 405

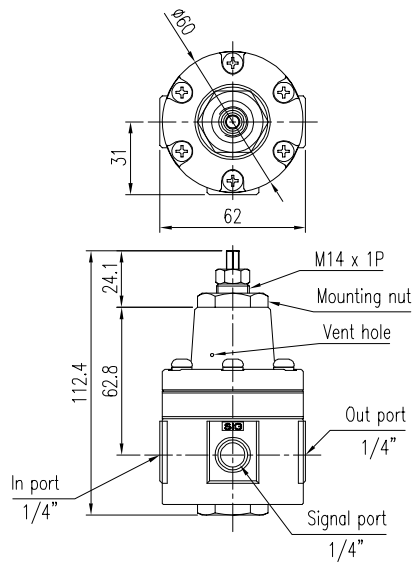

Single

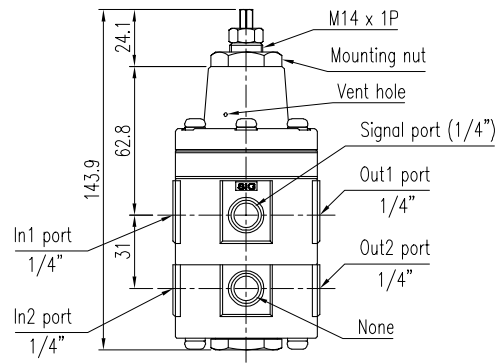

Double

2.6.2 YT-430 / 435

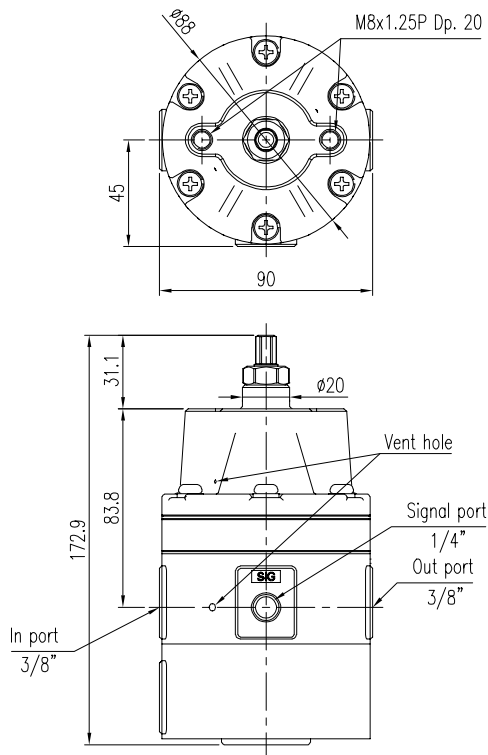

Single

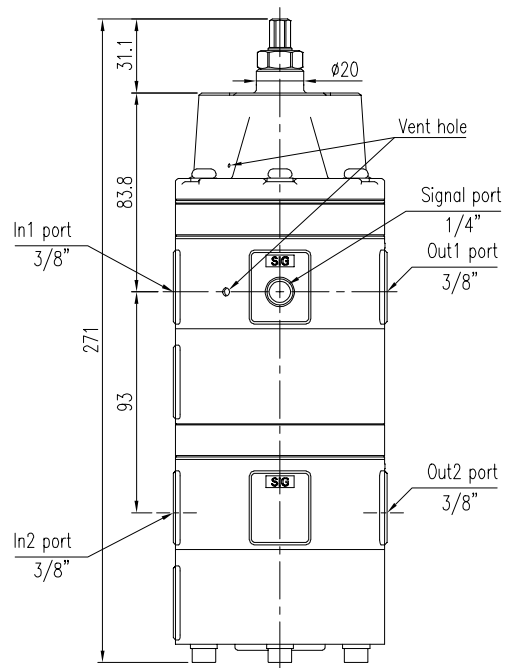

Double

2.7 Operation Logic

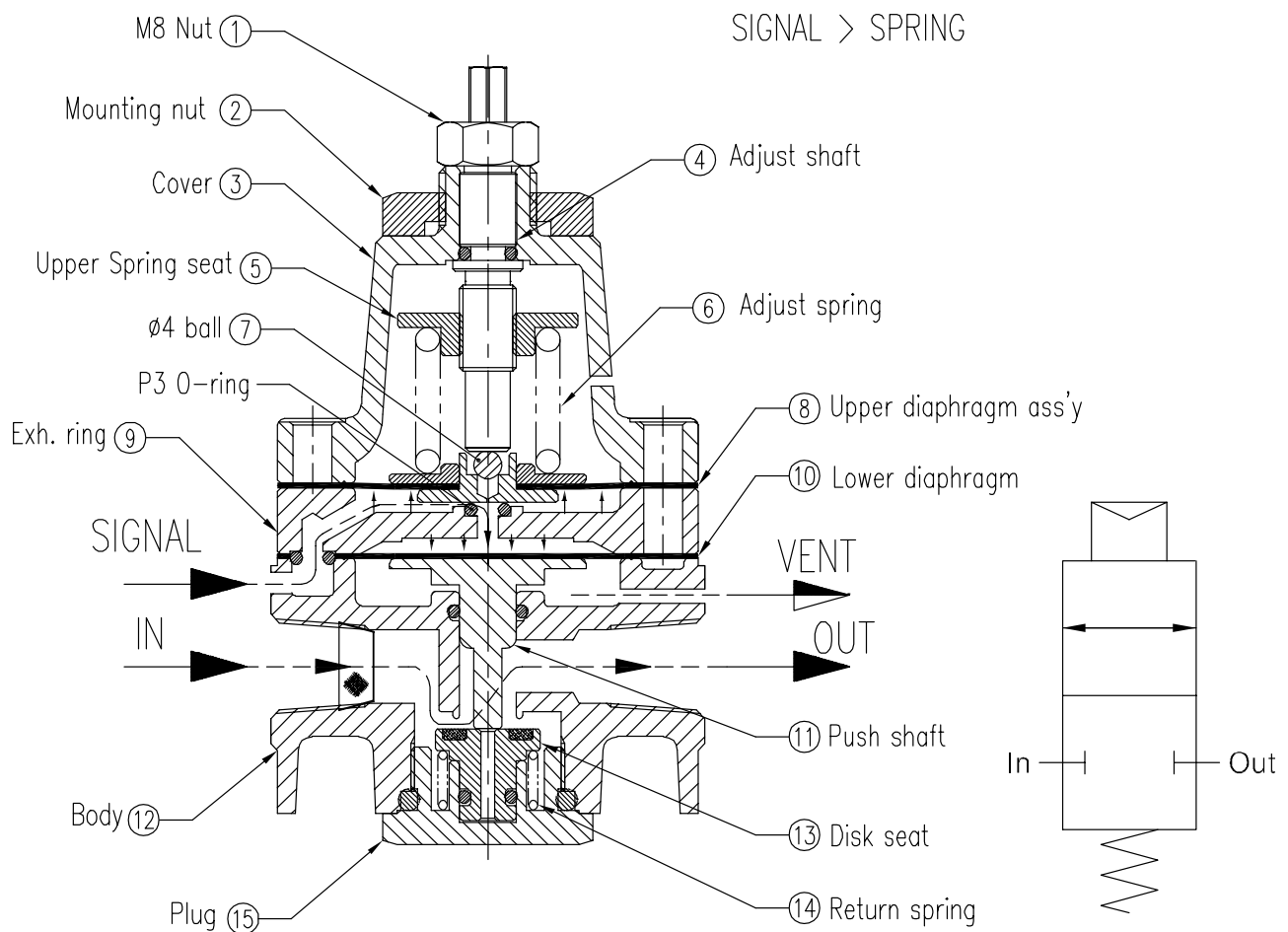

If the signal pressure is larger than the setting pressure (⑥adjustment spring force), the signal pressure lifts the ⑧upper diaphragm assembly upward. The signal pressure pushes the ⑪push shaft and ⑬disc seat down while pushing the ⑩lower diaphragm through the middle hole. As a result, the IN port is connected to the OUT port.

On the contrary, if the signal pressure is smaller than the setting pressure (⑥adjustment spring force), ⑧the upper diaphragm assembly will come down and the signal pressure will not go to the ⑩lower diaphragm, and the ⑦Ø4 ball will be separated from the ⑧upper diaphragm assembly. As a result, the air that has pushed down through the ⑩lower diaphragm is exhausted through the ⑦Ø4 ball, and the ⑭return spring raises the ⑬disc seat. As a result, the IN and OUT ports are blocked.

2.8 Section drawings

2.8.1 YT-400 / 405

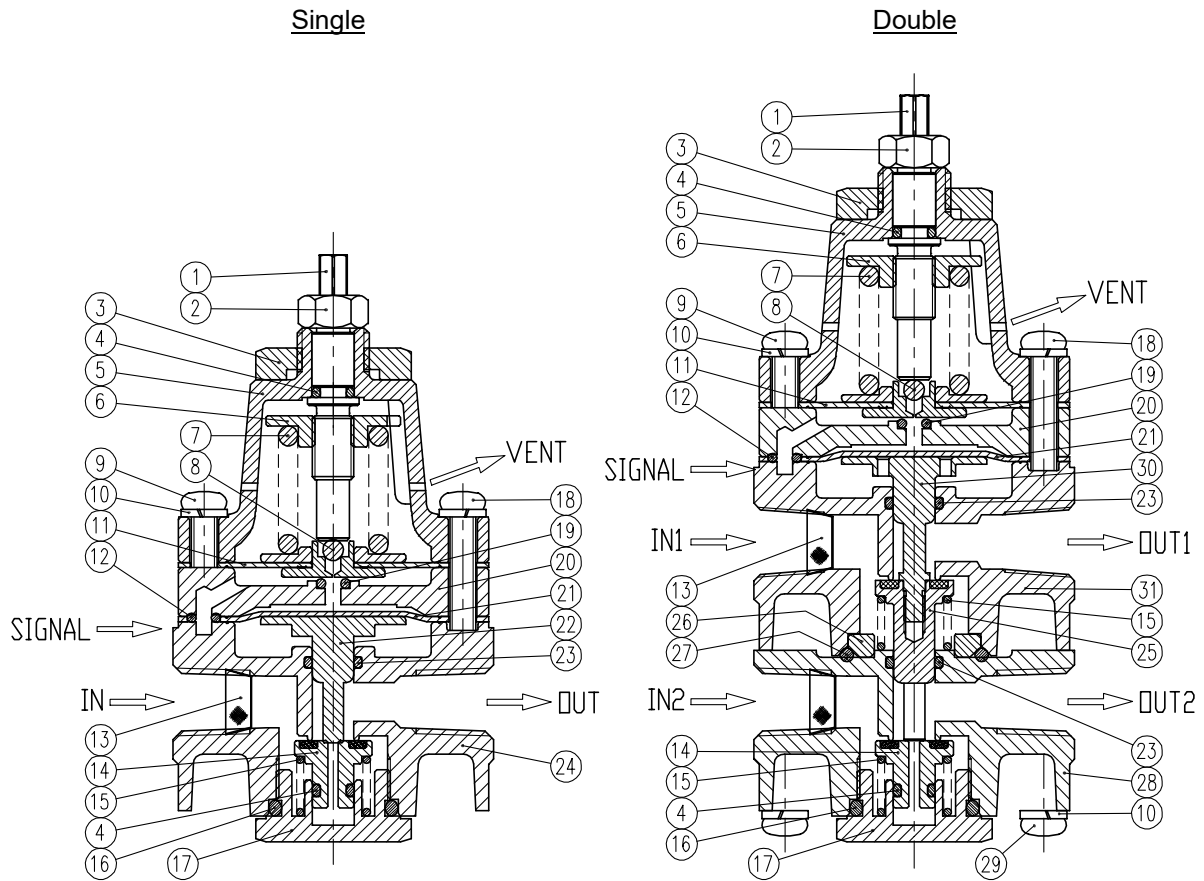

NO.	PART NAME
1	ADJUST SHAFT
2	NUT (M8x1P)
3	MOUNTING NUT
4	O-RING (P5)
5	BASE COVER
6	UPPER SPRING SEAT
7	ADJUST SPRING
8	BALL(φ4)
9	BOLT (M5x27, RH, 幸기공)
10	SPRING WASHER (M5)

NO.	PART NAME
11	UPPER DIAPHRAGM ASS'Y
12	O-RING(P3)
13	SCREEN (80MESH, 1/4")
14	LOWER SEAT
15	RETURN SPRING
16	O-RING (G20)
17	PLUG
18	BOLT(M5x30, RH, W/S)
19	O-RING (P3)
20	EXHAUST RING

NO.	PART NAME
21	LOWER DIAPHRAGM
22	SINGLE PUSH SHAFT
23	O-RING (P8)
24	SINGLE BASE BODY
25	LOWER PUSH SHAFT
26	SPRING BUSH
27	O-RING (AN119)
28	LOWER BASE BODY
29	BOLT (M5x40, RH)
30	DOUBLE PUSH SHAFT
31	UPPER BASE BODY

2.8.2 YT-430 / 435

Single

Double

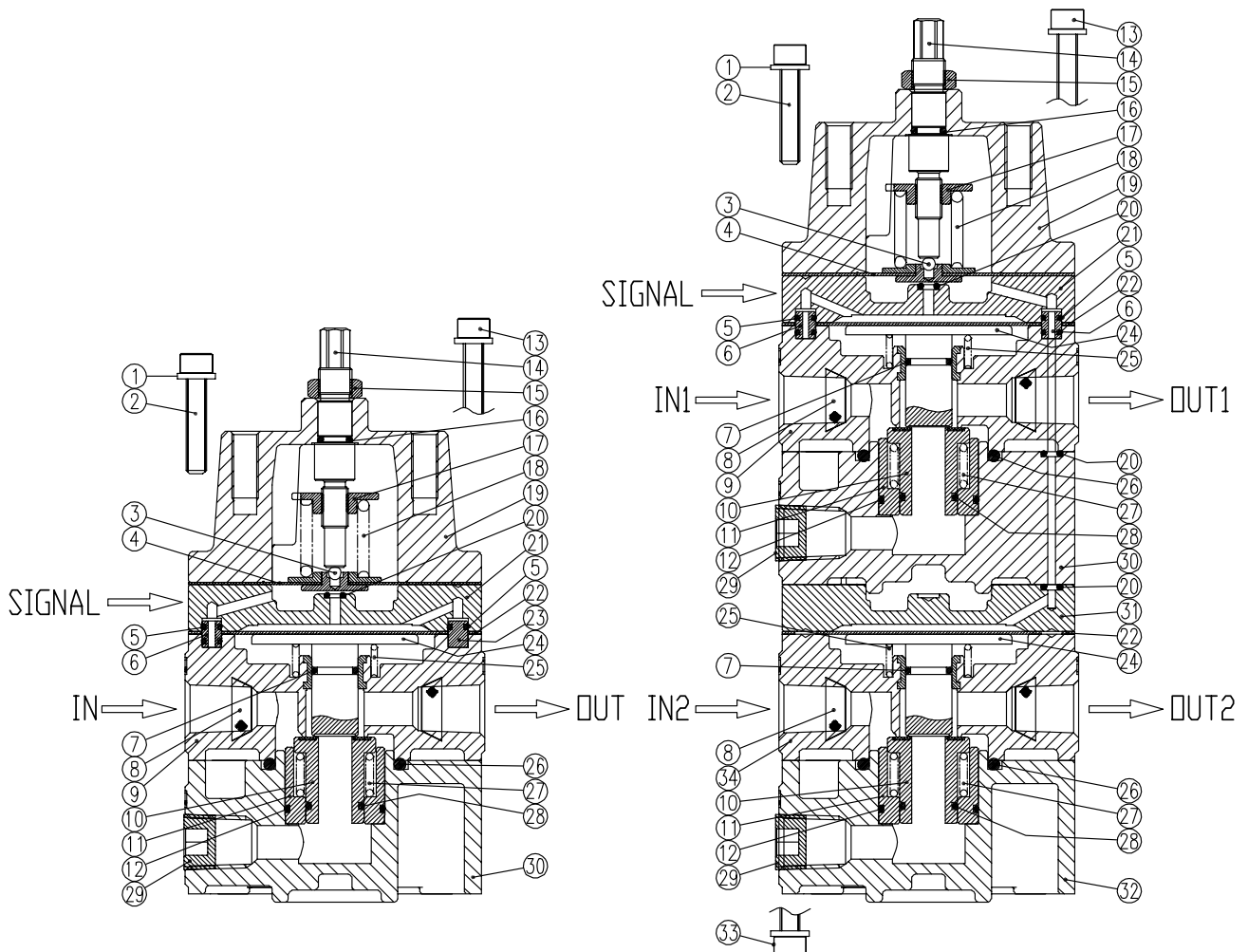

NO.	PART NAME
1	SPRING WASHER (M6)
2	BOLT (M6*30, WH)
3	BALL(φ4)
4	UPPER DIAPHRAGM ASS'Y
5	O-RING (S4)
6	SIGNAL TUBE-1
7	O-RING (P10)
8	SCREEN
9	BASE BODY-1
10	SEAT
11	LOWER BODY INSERT

NO.	PART NAME
12	O-RING (S26)
13	BOLT (M6*70, WH)
14	ADJUST SHAFT
15	LOCK NUT
16	O-RING (P7)
17	UPPER SPRING SEAT
18	ADJUST SPRING
19	BASE COVER
20	O-RING (P3)
21	EXHAUST RING-1
22	LOWER DIAPHRAGM

NO.	PART NAME
23	SIGNAL TUBE-2
24	PUSHER
25	PUSHER SPRING
26	O-RING(P36)
27	SEAT SPRING
28	O-RING(AN015)
29	PLUG (NPT 3/8")
30	LOWER BODY-1
31	EXHAUST RING-2
32	LOWER BODY-2
33	BOLT (M6*110, WH)
34	BASE BODY-2

3 Installation

3.1 Safety

When installing a unit, please ensure to read and follow safety instructions.

- Be sure to have protective equipment and comply with safety regulations.
- Use within specifications specified in the manual. Exceeding the specification may result in damage to the product or accident.
- The supply pressure must be clean, dry air and non-corrosive gas and must be filtered.
- Do not let impurities or foreign materials enter the lock-up valve, especially to the signal pressure port.
- Do not apply the signal pressure beyond the specified specification after piping connection. If the signal pressure exceeds the specified specification, the diaphragm may be damaged and the product may malfunction.
- When adjusting the set pressure after installation, temporarily install a pressure gauge or other equipment that can read the signal pressure and adjust the set pressure while reading the signal pressure. If the set pressure is adjusted without an instrument such as a pressure gauge, the product may be damaged by exceeding the specified specification or turning the adjustment screw too much.
- Be sure that the difference between setting pressure and signal pressure is over 0.1MPa.
- After setting the pressure, secure the nut so that the adjustment bolt does not turn.
- If there is any impact on the product, it may cause malfunction or failure, so be careful during handling, installation and operation.
- Install the product with the adjustment bolt facing up. Otherwise, the life cycle of the product may be shortened or moisture and foreign substance may enter into the vent hole, leading to damaging internal parts.

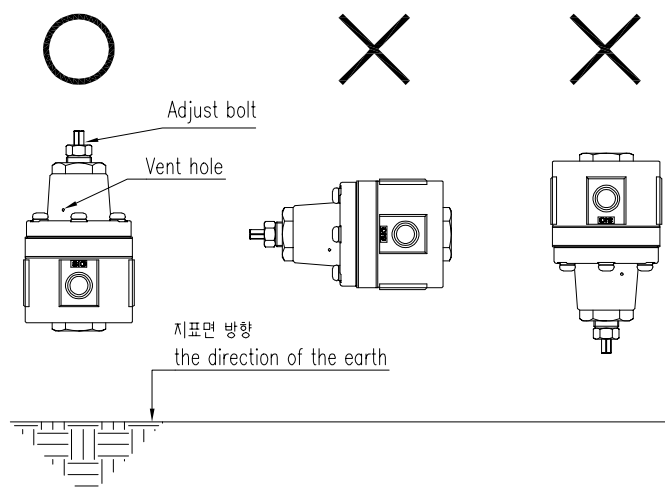

3.2 Installation

- The lock up valve can be installed with or without a bracket depending on the field conditions. The product can be installed using only pneumatic piping without a separate bracket.
- If you require brackets for installation, you can check the dimensions mentioned in the diagram on previous page and make the desired bracket type to suit each models. Below is an example of the lock up valve with bracket installation.

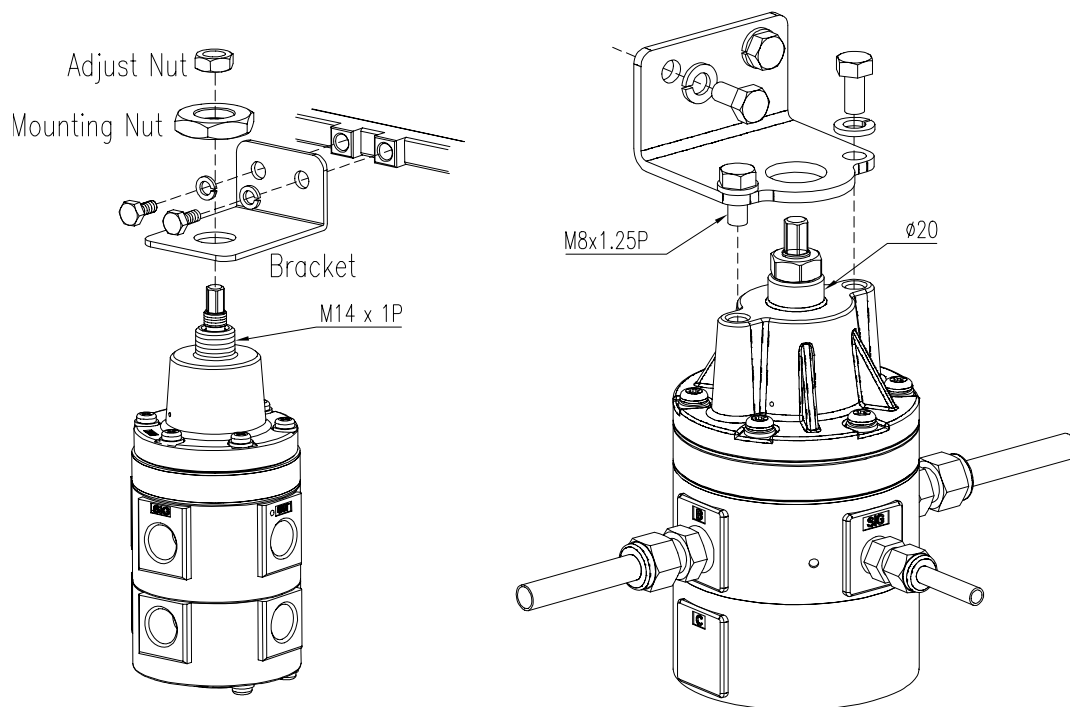

- Before connecting, be sure to blow out all piping to prevent impurities from entering in to the product and ensure that it is the right size meeting the required capacity.
- Turning the adjustment bolt clockwise increases the signal pressure setting.

3.3 Installation Example

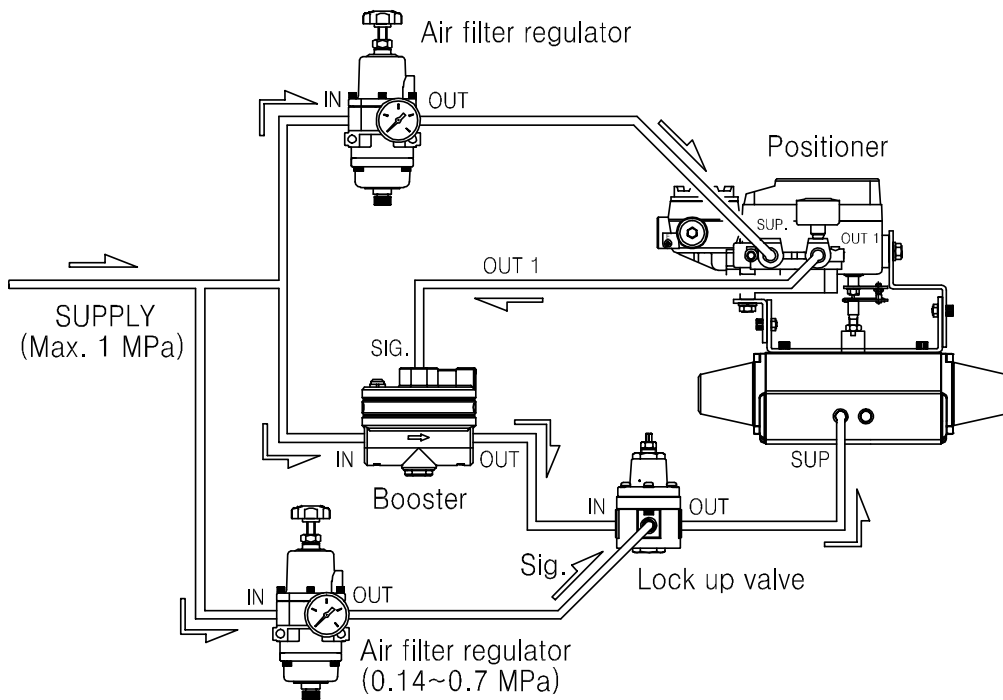

Single

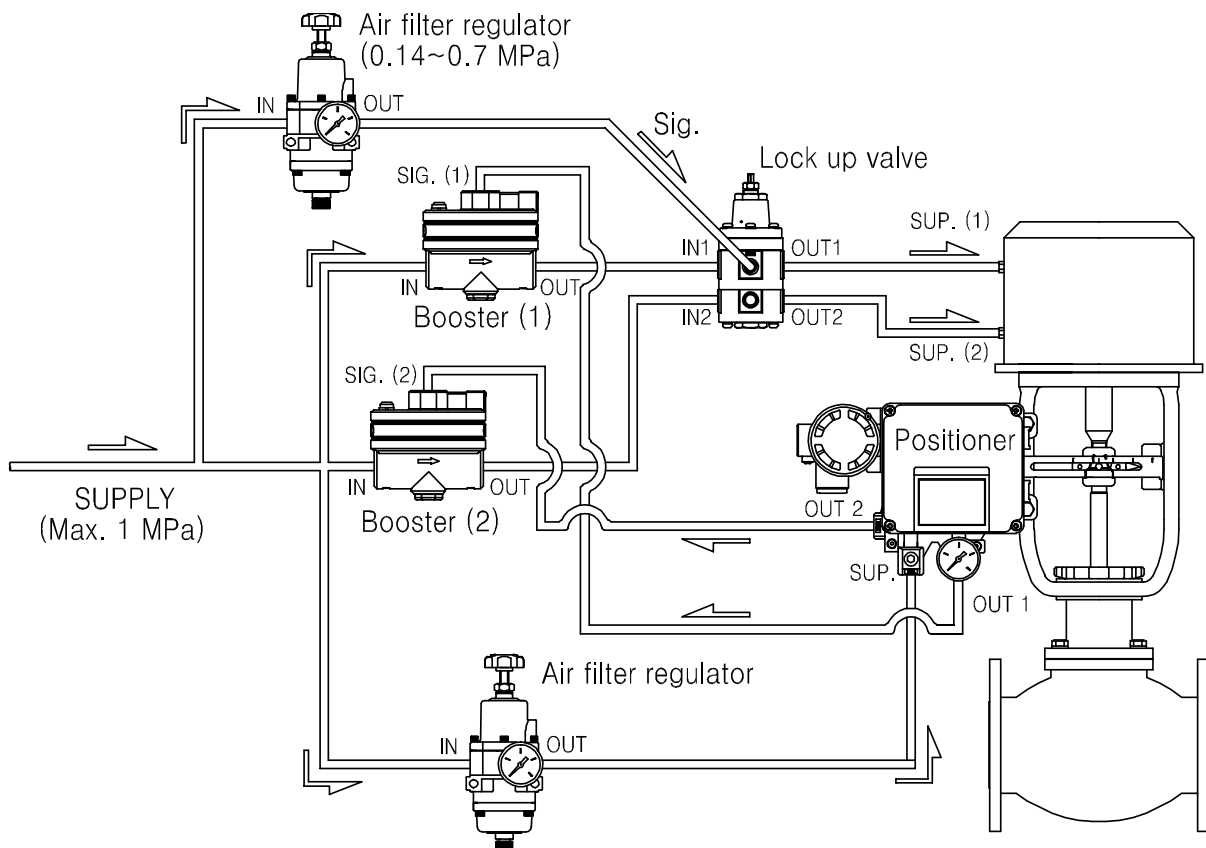

Double

4 Maintenance

4.1 Replacement of Parts (Repair kit)

The lock up valves require regular maintenance. If necessary, replace the following part.

- Upper diaphragm ass'y : 1 ea

4.2 Replacing Upper diaphragm ass'y

- When replacing the upper diaphragm ass'y, the main supply pressure to the product must be shut down completely.
- Loosen the nut of the adjust bolt and turn the adjust bolt counterclockwise until it does not feel repulsive force.
- Unscrew 6 bolts on spring case assembly in diagonal direction.
- Replace the upper diaphragm assembly with a new one and be careful not to lose the 4-pie steel ball on the top diaphragm assembly and the O-ring (P3) on the bottom.
- Lock the six bolts back on the base cover. Be careful not to damage the diaphragm due to excessive torque when tightening.
- Turn the adjust bolt to adjust the signal pressure setting. Then, lock the locking nut.

5 Trouble-Shooting

- 1) Lock up valve does not block pressure when signal pressure is lower than setting pressure level.
 - Please check if the setting pressure level is correct. If the setting pressure level is extremely high, please lower the setting pressure level. The factory default setting pressure level is 0.3 MPa

- 2) Lock up valve blocks pressure when signal pressure is higher than setting pressure level.
 - Please check if the setting pressure level is correct. If the setting pressure level is extremely low, please raise the setting pressure level.

- 3) When the air pressure is continuously discharged from the exhaust hole of the base cover.
 - The upper diaphragm may be damaged or foreign material may be attached to the steel ball placed in the middle of the upper diaphragm assembly. Replace the upper diaphragm assembly or clean any debris from the steel ball and reassemble.

- 4) When the air pressure is continuously discharged from the exhaust hole in the lock-up valve body.
 - The inner rubber part may be damaged. Please contact our Customer Support Department for repair.

Manufacturer: Rotork YTC Limited

Address: 81, Hwanggeum-ro, 89 Beon-gil, Yangchon-eup, Gimpo-si, Gyeonggi-do, South Korea

Postal code: 10048

Tel: +82-31-986-8545

Fax: +82-70-4170-4927

Email: ytic.sales@rotork.com

Homepage : <http://www.ytc.co.kr>

Issued : 2025-02-18

Copyright © Rotork YTC Limited. All Rights Reserved.