

REV.NO.	REVISION DESCRIPTION	DRAWN / DATE	REVIEWED / DATE	APPROVED / DATE
	Previous versions omitted			
4	PTM line modified	KCH/20191206	JJS/20191206	KTJ/20191206
5	Number range displys changed	KYJ/20241119	JJS/20241119	KTJ/20241119

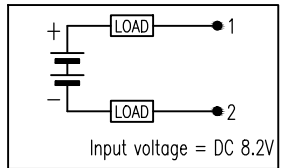

<PROXIMITY SENSOR(P&F) TERMINAL>

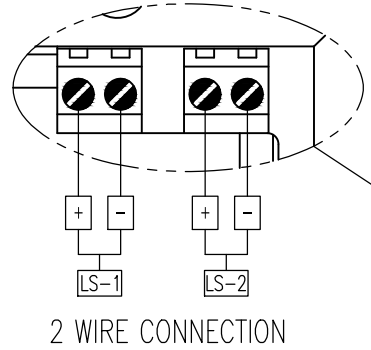
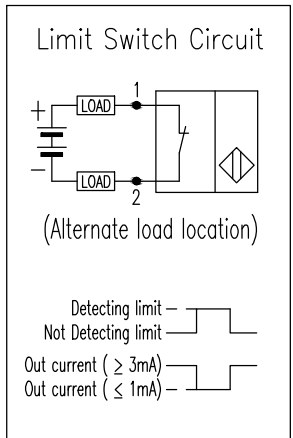
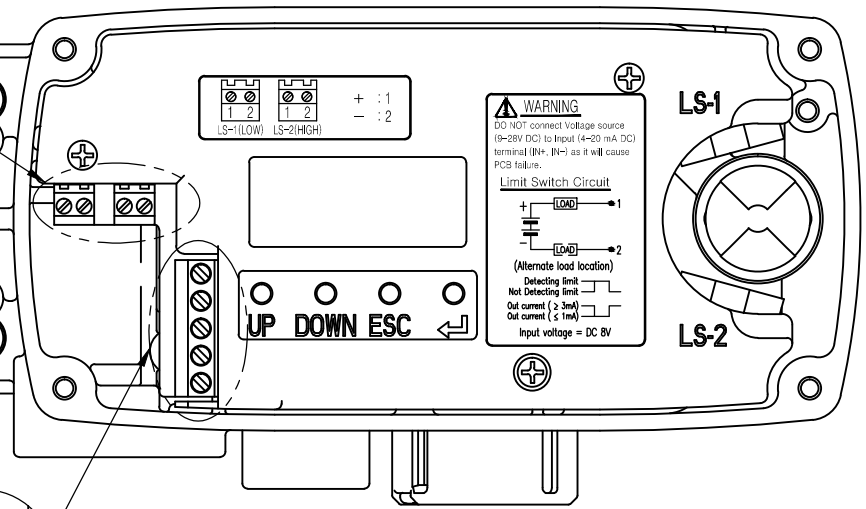

$$R_L \leq \frac{V_s[V] - 9[V]}{I [mA]}$$

R_L = Resistance value
(Power + Wire +
Monitoring system)

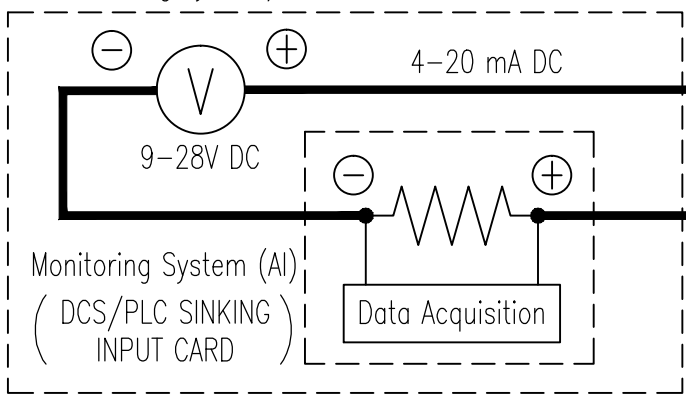
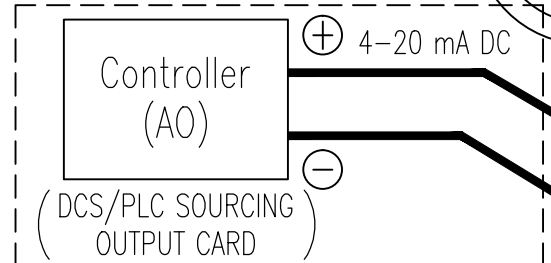

* P&F Proximity Sensor Spec.

Supply Voltage	DC 8.2V
Output Current	Not Detected : ≥ 3 mA, Detected : ≤ 1 mA
Type	Namur, NC

SURFACE TEXTURE	PRODUCT NAME	SMART POSITIONER	
FINISH TREATMENT	MODEL	YT-2500, 2550	
MATERIAL	PROJECTION	SCALE	
OTHERWISE NOTE	GENERAL TOLERANCE	QUANTITY	SHEET No.
		1	1 / 1

PROJECT NAME	
rotork Rotork YTC Limited GIMPO-SI., KOREA	
TITLE YT-2500/2550 + Analog Output + L/S(2xProximity) WIRING DIAGRAM	
DRAWING NO.	REV.
2500-09	5