



Contents

1	Introduction	5
1.1	General Information for the users	5
1.2	Manufacturer Warranty	5
1.3	Explosion Proof Warning (Only for Intrinsic safety type positioners)	6
2	Product Description	7
2.1	General	7
2.2	Main Features and Functions	7
2.3	Label Description	8
2.4	Product Code	11
2.4.1	YT-2500 / 2550 series follows suffix symbols as follows	11
2.4.2	YT-2501 series follows suffix symbols as follows	12
2.5	Product Specification	13
2.5.1	YT-2500 / 2550 Specification	13
2.5.2	YT-2501 Specification	14
2.6	Certifications	15
2.7	Parts and Assembly	16
2.8	Product Dimension	18
2.8.1	YT-2500	18
2.8.2	YT-2550	19
2.8.3	YT-2501	19
3	Installation	20
3.1	Safety	20
3.2	Tools for installation	20
3.3	Linear positioner Installation	21
3.3.1	Safety	21
3.3.2	Linear positioner Installation Steps	22
3.4	Rotary positioner Installation	25
3.4.1	YT-2500R / 2550R Components	25
3.4.2	YT-2501R remote sensor Components	25
3.4.3	Rotary Bracket information (Only YT-2500 / 2550)	26
3.4.4	Rotary positioner Installation Steps	27
4	Connection - Air	29
4.1	Safety	29
4.2	Supply Pressure Condition	29
4.3	Piping Condition	29
4.4	Connection – Piping with actuator	30
4.4.1	Single acting actuator	30
4.4.2	Double acting actuator	31
5	Connection – Power	32

5.1	Safety	32
5.2	Connection.....	32
5.3	Ground	34
6	Adjustments	35
6.1	Limit Switch Adjustment.....	35
6.2	Variable Orifice Adjustment	36
7	Optional Sub-PCB Installment	37
7.1	Installation steps	37
8	Maintenance	38
8.1	Supply air	38
8.2	Seals	38
9	Auto Calibration and Operation	39
9.1	Warning.....	39
9.2	Button Description	39
9.3	Run Mode (RUN)	40
9.4	Auto Calibration mode (AUTO CAL).....	40
9.4.1	AUTO1 Calibration (AUTO1)	41
9.4.2	AUTO2 Calibration (AUTO2)	41
9.4.3	AUTO3 Calibration (AUTO3)	41
9.5	Manual Mode (MANUAL).....	42
9.6	Parameter Mode (PARAM).....	42
9.6.1	Dead-Zone (dEAdZONE, %)	43
9.6.2	P1 Value (KP1)	43
9.6.3	D1 Value (Kd1)	44
9.6.4	P2 (KP2) and D2 (Kd2) values	44
9.6.5	P_ (KP_) and D_ (Kd_) Values.....	44
9.6.6	PT1 (PT1) and PT2 (PT2) Values.....	44
9.6.7	Period T (PERIOd T)	45
9.6.8	Auto DZ (AUTO dZ)	45
9.7	Hand Calibration Mode (HAND CAL)	46
9.7.1	Zero-Point (PV_ZERO) and End-Point (PV_END) for Valves.....	46
9.7.2	Zero-Point (TR_ZERO) and End-Point (TR_END) for 4-20 mA Analog Output.....	47
9.7.3	Normal / Reverse 4-20 mA Analog Output (TR NORM / REVS).....	48
9.7.4	Normal / Reverse HART Signal (HT NORM / REVS).....	48
9.8	Valve Mode (VALVE).....	48
9.8.1	Acting Adjustment (ACT RA / dA).....	49
9.8.2	Valve flow Characteristic Adjustment (CHAR).....	49
9.8.3	User defining flow Characteristics (USER SET).....	50
9.8.4	Tight Shut Open (TSHUT OP)	51
9.8.5	Tight Shut Close (TSHUT CL)	52

9.8.6	Split Range Mode (SPLIT).....	52
9.9	View Mode (VIEW)	53
10	Error and Warning Code	55
10.1	Error code which is displayed during Auto calibration	55
10.2	Error code which is displayed while using the product	56
10.3	Error code which can be checked from View mode	56
10.4	Warning code which can be checked from View mode	57
11	Main Software Map	58

1 Introduction

1.1 General Information for the users

Thank you for purchasing Rotork YTC Limited products. Each product has been fully inspected after its production to offer you the highest quality and reliable performance. Please read the product manual carefully prior to installing and commissioning the product.

- Installation, commissioning, and maintenance of the product may only be performed by trained specialist personnel who have been authorized by the plant operator accordingly.
- The manual should be provided to the end-user.
- The manual can be altered or revised without any prior notice. Any changes in product's specification, design, and/or any components may not be printed immediately but until the following revision of the manual.
- When the manual refers to "**Valve Zero / Zero**" means the final valve position upon pneumatic pressure has been fully exhausted from positioner's OUT1 port. For example, the valve zero position may differ between linear direct and reverse actions. (DA/RA)
- The manual should not be duplicated or reproduced for any purpose without prior approval from Rotork YTC Limited, Gimpo-si, South Korea.
- In case of any other problems that are not stated in this manual, please make immediate contact to Rotork YTC Limited.
- Positioner is an accessory of the control valve, so please make sure to read the applicable instruction manual of the control valve prior to installation and operation.

1.2 Manufacturer Warranty

- For the safety, it is important to follow the instructions in the manual. Manufacturer will not be responsible for any damages caused by user's negligence.
- Any modifications or repairs to the product may only be performed if expressed in this manual. Injuries and physical damages caused by customer's modifying or repairing the product without a prior consultation with Rotork YTC Limited will not be compensated. If any alterations or modifications are necessary, please contact Rotork YTC Limited directly.
- The warranty period for the product is (12) months from the date of shipment unless otherwise stated. Customers can extend the warranty period by an additional (12) months by registering the product's serial number or lot number, customer information, and installation address on the warranty extension application site Product Registration (<https://www.rotork.com/en/service/product-registration>).
- Manufacturer warranty will not cover products that have been subjected to abuse, accidents, alterations, modifications, tampering, negligence, misuse, faulty installation, lack of reasonable care, repair or service in any way that is not contemplated in the documentation for the product, or if the model or serial number has been altered, tampered with, defaced or removed; damages that occurs in shipment, due to act of God, failure due to power surge, or cosmetic damage.

Improper or incorrectly performed maintenance will void this limited warranty.

- In case of Fail Freeze product, it keeps the position of current valve in case of input current signal failure. However, please do not leave it in that state for a long time and take immediate action to restore the system. There is no fault in the positioner, but it is often reported that the valve is out of position due to an unexpected leak in the pipe or actuator.
- For detailed warranty information, please contact the corresponding local Rotork YTC Limited office or main office in South Korea.

1.3 Explosion Proof Warning (Only for Intrinsic safety type positioners)

Please ensure the unit is being used and installed in conformity with local, regional, and national explosion proof within the proper safety barrier environment.

- Refer to “2.6 Certifications”
- Explosion proof type of cables and gaskets should be used, when explosion gases are present at the installation site.
- Positioner has 2 ports for power connection. Explosion proof type wires and packing should be used. Blind plug is required when any port is not being used.
- Ring terminal with surface area of more than 1.25 mm² with M4 spring washer should be used to connect the power.
- For external ground terminal, ring terminal with surface area of more than 5.5 mm² should be used.
- Some of the enclosure parts are made of non-metallic materials. To prevent the risk of Electrostatic sparking, clean the enclosure only with a damp cloth.
- The product must be installed in such a manner as to minimize the risk of impact or friction with other metal surfaces.
- For Intrinsically Safe installations, the product must be connected to suitably rated intrinsically safe equipment, and must be installed in accordance with applicable intrinsically safe installation standards.
- Special conditions for safe use of sign “X” of ATEX / IECEx:

The ambient temperature range deviates from the standard temperature range and amounts:

Temperature class T5 / T100 °C: -30 °C to +60 °C

Temperature class T6 / T85 °C: -30 °C to +40 °C

Impact testing on light transmitting parts was carried out with low impact energy. Applications with a high risk of impact or with risk of high impact energies are to be avoided.



2 Product Description

2.1 General

YT-2500 / 2550 / 2501 series Smart Valve Positioner accurately controls valve stroke in response to an input signal of 4-20 mA from the controller. Built-in micro-processor optimizes the positioner's performance and provides unique functions such as **Auto-Calibration, PD Control, and HART Protocol Communications.**

2.2 Main Features and Functions

- When Input signal or supply pressure fails, Positioner keeps the current position of the valve stroke without any additional device. (Fail Freeze option)
- LCD display enables users to monitor the positioner status.
- User will easily understand the method of using 4 buttons because it work same in all versions of firmware interfaces.
- Positioner operates normally even there are sudden changes in supply pressure and / or high vibration environment.
- YT-2501 is stronger on high temperature and vibration environment because it is separated into remote sensor and positioner.
- The method of Auto Calibration is very simple.
- As an advantage of having very low air consumption, it could greatly reduce operating costs in large-scale plants.
- It is compatible with most of controllers.
- Variable orifices can be used to minimize the hunting occurrence and optimize operating conditions.
- Various information about positioner can be processed by HART communication. (option)
- Valve system becomes more stable by using 4-20 mA analog output function (option).
- Different valve characteristics can be adjusted – Linear, Quick Open, Equal Percentage, and User Set which user can make 5 points or 18 points characterizations.
- Tight Shut – Close and Shut - Open can be set.
- PD parameters can be adjusted in the field without any additional communicator.
- Split range 4 to 12 mA or 12 to 20 mA can be set.
- Operating temperature for remote sensor of YT-2501 series is -40 to 120 °C.
Operating temperature for positioners is -30 to 80 °C (Please check certified explosion proof temperature)
- Hand calibration function can set Zero point or End point manually.
- It has IP66 protection grade. (excluding the pressure gauges)
- Polyester powder coating resists the corrosion process. (except YT-2550)
- Maintenance of the positioner is easy because of modularized inner structure.

2.3 Label Description

- MODEL : Indicates the model number and additional options.
- EXPLOSION PROOF : Indicates certified explosion proof grade.
- INGRESS PROTECTION : Indicates enclosure protection grade.
- INPUT SIGNAL : Indicates input signal range.
- OPERATING TEMP. : Indicates the allowable operating temperature.
- SUPPLY PRESSURE : Indicates the supply pressure range.
- SERIAL NUMBER : Indicates unique serial number.
- MONTH.YEAR : Indicates manufactured month and year.

- INTRINSIC SAFETY / NONINCENDIVE : Indicates intrinsic safety explosion proof grade.
- AMBIENT TEMP. : Indicates the allowable ambient temperature for explosion proof
- Ui, li, Pi, Ci, Li : Indicates the allowable electrical data in the certificate. You can see the details in the certificate.

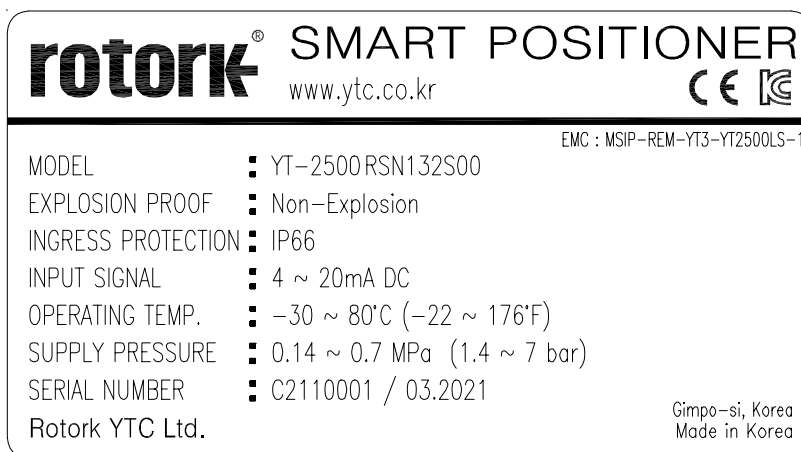

Fig. L-1: YT-2500 Non-explosion proof

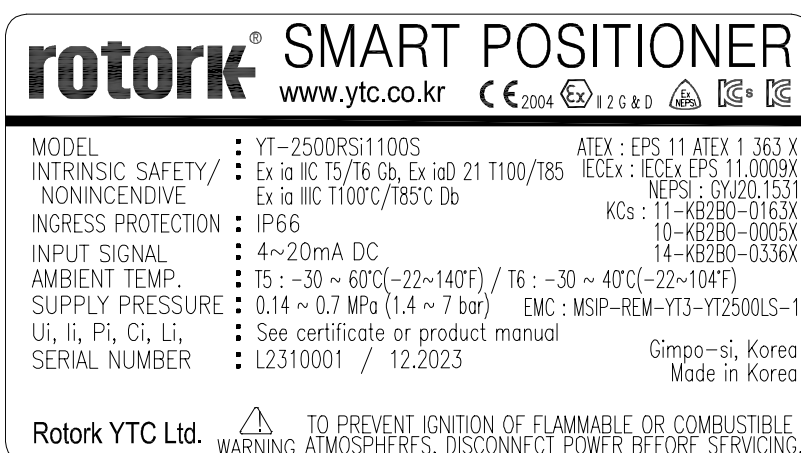

Fig. L-2: YT-2500 Intrinsic safety type (ATEX, IECEx, NEPSI, KCs)

rotork 智能阀门定位器		CE 2004 Ex II 2 G & D
www.ytc.co.kr		CCC NEPSI KCS
型号	: YT-2500RSZ1100S	ATEX :EPS 11 ATEX 1 363 X
本安/非易燃	: Ex ia IIC T5/T6 Gb, Ex iaD 21 T100/T85	IECEX : IECEx EPS 11.0009X
	Ex ia IIIC T85°C/T100°C Db	NEPSI : GYJ20.1531
防护等级	: IP66	KCs : 11-KB2BO-0163X
输入信号	: 4~20mA DC	10-KB2BO-0005X
防爆环境温度	: T5 : -30 ~ 60°C(-22~140°F) / T6 : -30 ~ 40°C(-22~104°F)	14-KB2BO-0336X
供给压力	: 0.14 ~ 0.7 MPa (1.4 ~ 7 bar)	EMC : MSIP-REM-YT3-YT2500LS-1
Ui, li, Pi, Ci, Li,	: 请参阅证书或产品手册	金浦市, 韩国
序列号	: L2310001 / 12.2023	韩国制造
Rotork YTC Ltd.  为防止点燃易燃或可燃气体, 请在维修之前断开电源。		

Fig. L-3: YT-2500 Intrinsic safety type (CCC, NEPSI)

rotork SMART POSITIONER		CE
www.ytc.co.kr		
MODEL	: YT-2550 RSN1100S	
EXPLOSION PROOF	: Non-Explosion	
INGRESS PROTECTION	: IP66	
INPUT SIGNAL	: 4 ~ 20mA DC	
OPERATING TEMP.	: -30 ~ 80°C (-22 ~ 176°F)	
SUPPLY PRESSURE	: 0.14 ~ 0.7 MPa (1.4 ~ 7 bar)	
SERIAL NUMBER	: C2110001 / 03.2021	
Rotork YTC Ltd.		Gimpo-si, Korea Made in Korea

Fig. L-4: YT-2550 Non-explosion proof

rotork SMART POSITIONER		CE 2004 Ex II 2 G & D
www.ytc.co.kr		NEPSI KCS
MODEL	: YT-2550 RSi1100S	ATEX : EPS 11 ATEX 1 363 X
INTRINSIC SAFETY/	: Ex ia IIC T5/T6 Gb, Ex iaD 21 T100/T85	IECEX : IECEx EPS 11.0009X
NONINCENDIVE	: Ex ia IIIC T100°C/T85°C Db	NEPSI : GYJ20.1531
INGRESS PROTECTION	: IP66	KCs : 11-KB2BO-0165X
INPUT SIGNAL	: 4~20mA DC	11-KB2BO-0166X
AMBIENT TEMP.	: T5 : -30 ~ 60°C(-22 ~ 140°F) / T6 : -30 ~ 40°C(-22 ~ 104°F)	14-KB2BO-0337X
SUPPLY PRESSURE	: 0.14 ~ 0.7 MPa (1.4 ~ 7 bar)	
Ui, li, Pi, Ci, Li,	: See certificate or product manual	
SERIAL NUMBER	: L2310001 / 12.2023	
Rotork YTC Ltd.		Gimpo-si, Korea Made in Korea
 TO PREVENT IGNITION OF FLAMMABLE OR COMBUSTIBLE ATMOSPHERES, DISCONNECT POWER BEFORE SERVICING.		

Fig. L-5: YT-2550 Intrinsic safety type (ATEX, IECEx, NEPSI, KCs)

rotork 智能阀门定位器		CE 2004 Ex II 2 G & D
www.ytc.co.kr		CCC NEPSI KCS
型号	: YT-2550 RSi1100S	ATEX : EPS 11 ATEX 1 363 X
本安/非易燃	: Ex ia IIC T5/T6 Gb, Ex iaD 21 T100/T85	IECEX : IECEx EPS 11.0009X
	Ex ia IIIC T85°C/T100°C Db	NEPSI : GYJ20.1531
防护等级	: IP66	KCs : 11-KB2BO-0165X
输入信号	: 4~20mA DC	11-KB2BO-0166X
防爆环境温度	: T5 : -30 ~ 60°C(-22 ~ 140°F) / T6 : -30 ~ 40°C(-22 ~ 104°F)	14-KB2BO-0337X
供给压力	: 0.14 ~ 0.7 MPa (1.4 ~ 7 bar)	
Ui, li, Pi, Ci, Li,	: 请参阅证书或产品手册	
序列号	: L2310001 / 12.2023	
Rotork YTC Ltd.		金浦市, 韩国 韩国制造
 为防止点燃易燃或可燃气体, 请在维修之前断开电源。		

Fig. L-6: YT-2550 Intrinsic safety type (CCC, NEPSI)

rotork ® SMART POSITIONER		www.ytc.co.kr	CE
MODEL	:	YT-2501RSN1100S	
EXPLOSION PROOF	:	Non-Explosion	
INGRESS PROTECTION	:	IP66	
INPUT SIGNAL	:	4 ~ 20mA DC	
OPERATING TEMP.	:	-30 ~ 80°C (-22 ~ 176°F)	
SUPPLY PRESSURE	:	0.14 ~ 0.7 MPa (1.4 ~ 7 bar)	
SERIAL NUMBER	:	C2110001 / 03.2021	
Rotork YTC Ltd.			Gimpo-si, Korea Made in Korea

Fig. L-7: YT-2501 Non-explosion proof

rotork ® SMART POSITIONER		www.ytc.co.kr	CE 2004	Ex II 2 G & D	NEPSI	KCS
MODEL	:	YT-2501RSI1100S	ATEX :	EPS 11 ATEX 1 363 X		
INTRINSIC SAFETY/ NONINCENDIVE	:	Ex ia IIC T5/T6 Gb, Ex iaD 21 T100/T85	IECEX :	IECEX EPS 11.0009X	NEPSI :	GYJ20.1531
		Ex ia IIIC T100°C/T85°C Db			KCs :	11-KB2BO-0164X
INGRESS PROTECTION	:	IP66				
INPUT SIGNAL	:	4 ~ 20mA DC				
AMBIENT TEMP.	:	T5 : -30 ~ 60°C (-22~140°F) / T6 : -30 ~ 40°C (-22~104°F)				
SUPPLY PRESSURE	:	0.14 ~ 0.7 MPa (1.4 ~ 7 bar)				
Ui, li, Pi, Ci, Li,	:	See certificate or product manual			Gimpo-si, Korea	
SERIAL NUMBER	:	L2310001 / 12.2023			Made in Korea	
Rotork YTC Ltd.			 TO PREVENT IGNITION OF FLAMMABLE OR COMBUSTIBLE WARNING ATMOSPHERES, DISCONNECT POWER BEFORE SERVICING.			

Fig. L-8: YT-2501 Intrinsic safety type (ATEX, IECEX, NEPSI, KCs)

rotork ® 智能阀门定位器		www.ytc.co.kr	CE 2004	Ex II 2 G & D	CCC	NEPSI	KCS
型号	:	YT-2501RSZ1100S	ATEX :	EPS 11 ATEX 1 363 X			
本安/非易燃	:	Ex ia IIC T5/T6 Gb, Ex iaD 21 T100/T85	IECEX :	IECEX EPS 11.0009X	NEPSI :	GYJ20.1531	
		Ex ia IIIC T85°C/T100°C Db			KCs :	11-KB2BO-0164X	
防护等级	:	IP66					
输入信号	:	4~20mA DC					
防爆环境温度	:	T5 : -30 ~ 60°C (-22~140°F) / T6 : -30 ~ 40°C (-22~104°F)					
供给压力	:	0.14 ~ 0.7 MPa (1.4 ~ 7 bar)					
Ui, li, Pi, Ci, Li,	:	请参阅证书或产品手册			金浦市, 韩国		
序列号	:	L2310001 / 12.2023			韩国制造		
Rotork YTC Ltd.			 警告 为防止点燃易燃或可燃气体, 请在维修之前断开电源。				

Fig. L-9: YT-2501 Intrinsic safety type (CCC, NEPSI)

2.4 Product Code

2.4.1 YT-2500 / 2550 series follows suffix symbols as follows.

YT-2500 / 2550 1 2 3 4 5 6 7 8

1	Motion Type	L : Linear R : Rotary
2	Acting type	S : Single D : Double
3	Explosion Protection	N : Non-Explosion proof i : Intrinsic safety : KCs, ATEX, IECEx, NEPSI Z : Intrinsic safety : CCC, NEPSI
4	Lever Type	Linear 1 : 10 to 40 mm 2 : 20 to 70 mm 3 : 50 to 100 mm 4 : 100 to 150 mm
		Rotary 1 : M6 x 34L 2 : M6 x 63L 3 : M8 x 34L 4 : M8 x 63L 5 : Namur
5	Conduit – Air Connection Type	1 : G 1/2 – Rc 1/4 2 : G 1/2 – 1/4 NPT (YT-2550 is available for No. 2 ONLY) 3 : G 1/2 – G 1/4 4 : M20x1.5P – 1/4 NPT 5 : 1/2 NPT – 1/4 NPT
6	Communication	0 : None 2 : HART Communication
7	Option ¹⁾	0 : None 1 : 4-20 mA Analog Output 2 : Limit Switch(Mechanical Type, 2ea) 3 : Limit Switch(Inductive proximity Type, 2ea) ²⁾ 4 : 4-20 mA Analog Output and Limit Switch(Mechanical Type, 2ea) 5 : 4-20 mA Analog Output and Limit Switch(Inductive proximity Type, 2ea) ³⁾
8	Fail Option	F : Fail Freeze S : Fail Safe

- 1) In case of YT-2550 Linear, Limit Switch options(2 to 5 in 7) cannot be selected.
 2) 3) Operating temp. of inductive proximity limit switch is from 25 to 80 °C (-13 to 176 °F).

2.4.2 YT-2501 series follows suffix symbols as follows.

YT-2501 1 2 3 4 5 6 7 8 9

1 Motion Type	L : Linear R : Rotary				
2 Acting type	S : Single D : Double				
3 Explosion Protection	N : Non-Explosion proof i : Intrinsic safety : KCs, ATEX, IECEx, NEPSI Z : Intrinsic safety : CCC, NEPSI				
4 Lever Type	<table border="1" style="width: 100%; border-collapse: collapse;"> <tr> <td style="border: none;">Linear</td> <td style="border: none;">1 : 10 to 40 mm 2 : 20 to 70 mm 3 : 50 to 100 mm 4 : 100 to 150 mm</td> </tr> <tr> <td style="border: none;">Rotary</td> <td style="border: none;">5 : Namur</td> </tr> </table>	Linear	1 : 10 to 40 mm 2 : 20 to 70 mm 3 : 50 to 100 mm 4 : 100 to 150 mm	Rotary	5 : Namur
Linear	1 : 10 to 40 mm 2 : 20 to 70 mm 3 : 50 to 100 mm 4 : 100 to 150 mm				
Rotary	5 : Namur				
5 Conduit – Air Connection Type	1 : G 1/2 – Rc 1/4 2 : G 1/2 – 1/4 NPT 3 : G 1/2 – G 1/4 4 : M20x1.5P(Adapter type) – 1/4 NPT 5 : 1/2 NPT(Adapter type) – 1/4 NPT				
6 Communication	0 : None 2 : HART Communication				
7 Option	0 : None 1 : 4-20 mA Analog Output				
8 Fail Option	F : Fail Freeze S : Fail Safe				
9 Cable Length ¹⁾	1 : 5 m 2 : 10 m 3 : 15 m 4 : 20 m				

¹⁾ Maximum cable length is 20 m.

2.5 Product Specification

2.5.1 YT-2500 / 2550 Specification

Model		YT-2500		YT-2550	
Housing Material		Aluminum		Stainless steel 316	
Motion Type		Linear	Rotary	Linear	Rotary
Acting Type		Single / Double			
Input Signal		4-20 mA DC			
Minimum Current Signal		3.5 mA(Standard), 3.8 mA(HART option)			
Supply Pressure		0.14 to 0.7 MPa (1.4 to 7 bar)			
Stroke		10 to 150 mm	55 to 110°	10 to 150 mm	55 to 110°
Impedance		Max. 500 Ω @ 20 mA DC			
Conduit Entry		G 1/2 or 1/2 NPT or M20x1.5P		G 1/2	
Air Connection		Rc 1/4 or G 1/4 or 1/4 NPT		1/4 NPT	
Gauge Connection		Rc 1/8 or 1/8 NPT		1/8 NPT	
Ingress Protection		IP66 (excluding the pressure gauges)			
Explosion Protection		1. Non-Explosion proof 2. Ex ia IIC T5/T6 Gb, Ex ia IIIC T100°C/T85°C Db Ex iaD 21 T100/T85 ※ See "2.6 Certificates" for details			
Operating Temperature		-30 to 80 °C (-22 to 176 °F) Inductive proximity limit switch internal type :-25 to 80 °C (-13 to 176 °F)			
Ambient Temperature Of Explosion proof	T5	-30 to 60 °C (-22 to 140 °F)			
	T6	-30 to 40 °C (-22 to 104 °F)			
Linearity		± 0.5 % F.S.			
Hysteresis		± 0.5 % F.S.			
Sensitivity		± 0.2 % F.S.			
Repeatability		± 0.3 % F.S.			
Flow Capacity	Fail Freeze	60 LPM (Sup. = 0.14 MPa)			
	Fail Safe	40 LPM (Sup. = 0.14 MPa)			
Air Consumption	Fail Freeze	0.01 LPM (Sup. = 0.14 MPa)			
	Fail Safe	0.06 LPM (Sup. = 0.14 MPa)			
Output Characteristic		Linear, Quick Open, EQ%, User Set			
Vibration		No Resonance up to 100 Hz @ 6 G			
Humidity		5 to 95 % RH @ 40 °C			
Communication (Option)		HART Communication (HART 5)			
Analog Output (Option)		4-20 mA (DC 9 to 28 V)			
L/S Rating (Option)	Mechanical	AC 125 V 3 A / DC 30 V 2 A (2ea)			
	Inductive Proximity	DC 8.2 V 8.2 mA (2ea)			
Weight		1.5 kg (3.3 lb)		2.9 kg (6.4 lb)	

Painting	Polyester Powder Coating	-
-----------------	--------------------------	---



Tested under ambient temperature of 20 °C, absolute pressure of 760 mmHg, and humidity of 65 %.

Please contact Rotork YTC Limited for detailed testing specification.

2.5.2 YT-2501 Specification

Model	YT-2501	
Housing Material	Aluminum	
Motion Type	Linear	Rotary
Acting Type	Single / Double	
Input Signal	4-20 mA DC	
Minimum Current Signal	3.5 mA(Standard), 3.8 mA(HART option)	
Supply Pressure	0.14 to 0.7 MPa (1.4 to 7 bar)	
Stroke	10 to 150 mm	55 to 110°
Impedance	Max. 500 Ω @ 20 mA DC	
Conduit Entry	G 1/2 or 1/2 NPT 1/2 or M20x1.5P	
Air Connection	Rc 1/4 or G 1/4 or 1/4 NPT	
Gauge Connection	Rc 1/8 or 1/8 NPT	
Ingress Protection	IP66 (excluding the pressure gauges)	
Explosion Protection	3. Non-Explosion proof 4. Ex ia IIC T5/T6 Gb, Ex ia IIIC T100°C/T85°C Db Ex iaD 21 T100/T85 ※ See "2.6 Certificates" for details	
Operating Temperature	Sensor	-55 to 120 °C (-67 to 248 °F)
	Body	-30 to 80 °C (-22 to 176 °F)
Ambient Temperature Of Explosion proof	T5	-30 to 60 °C (-22 to 140 °F)
	T6	-30 to 40 °C (-22 to 104 °F)
Linearity	± 0.5 % F.S.	
Hysteresis	± 0.5 % F.S.	
Sensitivity	± 0.2 % F.S.	
Repeatability	± 0.3 % F.S.	
Flow Capacity	Fail Freeze	60 LPM (Sup. = 0.14 MPa)
	Fail Safe	40 LPM (Sup. = 0.14 MPa)
Air Consumption	Fail Freeze	0.01 LPM (Sup. = 0.14 MPa)
	Fail Safe	0.06 LPM (Sup. = 0.14 MPa)
Output Characteristic	Linear, Quick Open, EQ%, User Set	
Vibration	No Resonance up to 100 Hz @ 6 G	
Humidity	5 to 95 % RH @ 40 °C	
Communication (Option)	HART Communication (HART 5)	
Analog Output (Option)	4-20 mA (DC 9 to 28 V)	

Weight	Positioner	1.6 kg (3.4 lb)	
	Sensor	0.6 kg (1.2 lb)	1.0 kg (2.1 lb)
	Cable(5M)	0.6 kg (1.3 lb)	
Painting		Polyester Powder Coating	



Tested under ambient temperature of 20 °C, absolute pressure of 760 mmHg, and humidity of 65 %

Please contact Rotork YTC Limited for detailed testing specification.

2.6 Certifications

※ All certifications below are posted on Rotork YTC Limited homepage(www.ytc.co.kr).

➤ **KCs (Korea)**

Type : Intrinsic safety

Rating : Ex ia IIC T5/T6, Ex iaD IIIC T100°C/T85°C

Certification No. : 11-KB2BO-0163X(YT-2500)

10-KB2BO-0005X(YT-2500+LS(Dry contact))

14-KB2BO-0336X(YT-2500+LS(Non-contact))

11-KB2BO-0165X(YT-2550)

11-KB2BO-0166X(YT-2550+LS(Dry contact))

14-KB2BO-0337X(YT-2550+LS(Non-contact))

11-KB2BO-0164X(YT-2501)

Ambient temperature : -30 to +60°C (T5/T100°C), -30 to +40°C (T6/T85°C)

➤ **ATEX**

Type : Intrinsic safety

Rating : II 2G Ex ia IIC T5/T6 Gb, II 2D Ex ia IIIC T100°C/T85°C Db IP6X

Certification No. : EPS 11 ATEX 1 363 X

Ambient temperature : -30 to +60°C (T5), -30 to +40°C (T6)

➤ **IECEX**

Type : Intrinsic safety

Rating : Ex II 2G Ex ia IIC T5/T6 Gb, Ex II 2D Ex ia IIIC T100°C/T85°C Db IP6X

Certification No. : IECEx EPS 11.0009X

Ambient temperature : -30 to +60°C (T5/T100°C), -30 to +40°C (T6/T85°C)

➤ **NEPSI**

Type : Intrinsic safety

Rating : Ex ia IIC T5/T6 Gb, Ex iaD 21 T100/T85

Certification No. : GYJ20.1531

➤ **CCC (China)**

Type : Intrinsic safety

Rating : Ex ia IIC T5/T6 Gb, Ex ia IIIC T85°C/T100°C Db

Certification No. : 20200322307000618

Ambient temperature : -30 to +60°C (T5/T100°C), -30 to +40°C (T6/T85°C)

➤ **Electromagnetic Compatibility (EMC)**

- EMC directive 2014/30/EC from April 2016
- EC Directive for CE conformity marking

2.7 Parts and Assembly

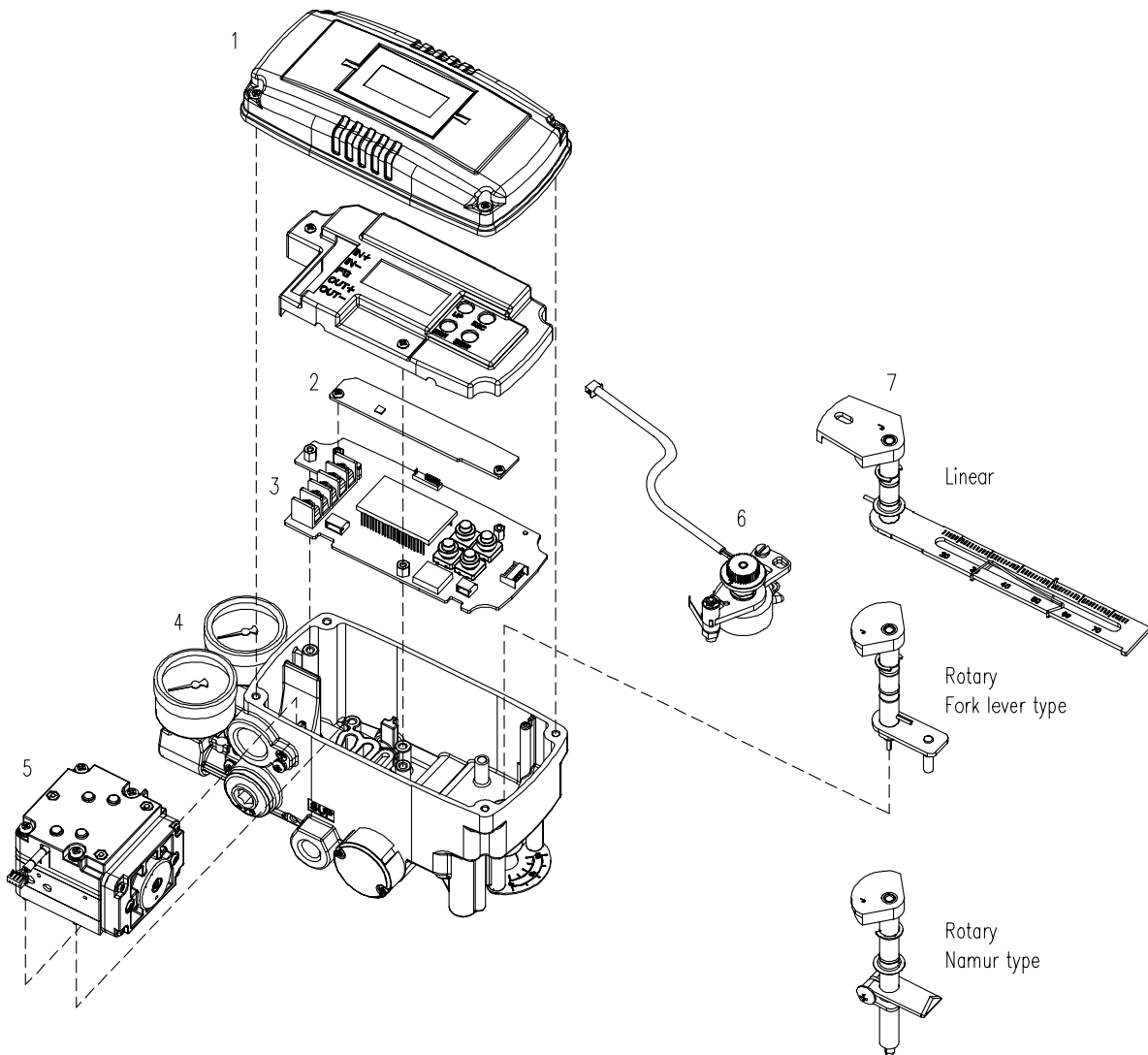

Fig. 2-1: YT-2500 / 2550 series exploded view

- | | |
|-------------------|-------------------|
| 1. Base Cover | 6. Potentiometer |
| 2. Option PCB | 7. Main shaft |
| 3. Main PCB | 8. Base body |
| 4. Pressure Gauge | 9. Feedback Lever |
| 5. Pilot | |

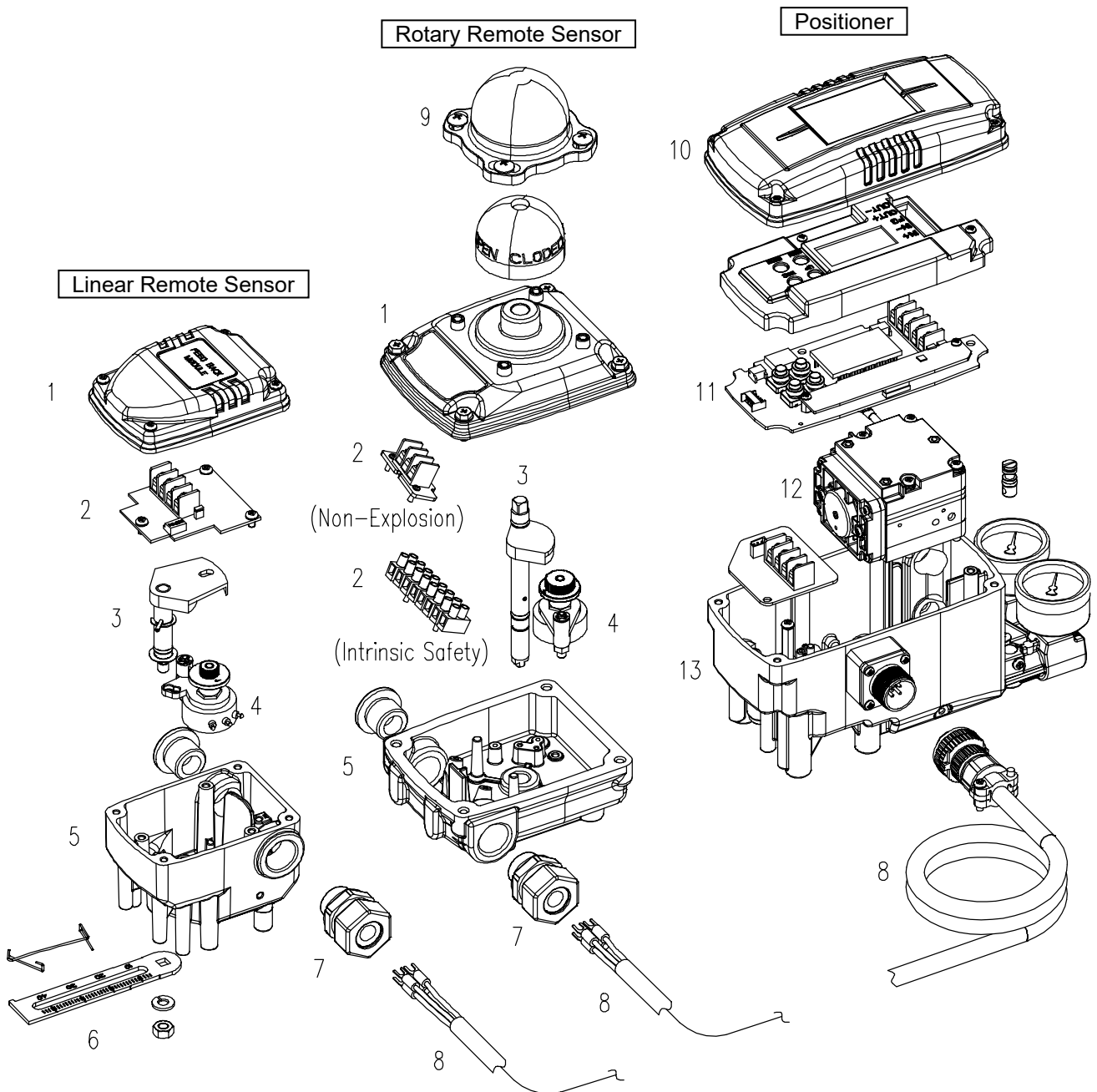

Fig. 2-2: YT-2501 exploded view

- | | |
|-------------------------------------|------------------------------|
| 1. Base cover of Remote sensor | 10. Base cover of Positioner |
| 2. Terminal of Remote sensor | 11. PCB of Positioner |
| 3. Main shaft of Remote sensor | 12. Pilot of Positioner |
| 4. Potentiometer of Remote sensor | 13. Base body of Positioner |
| 5. Base body of Remote sensor | |
| 6. Lever of Remote sensor | |
| 7. Cable connector of Remote sensor | |
| 8. Remote cable | |
| 9. Dome cover of Remote sensor | |

2.8 Product Dimension

2.8.1 YT-2500

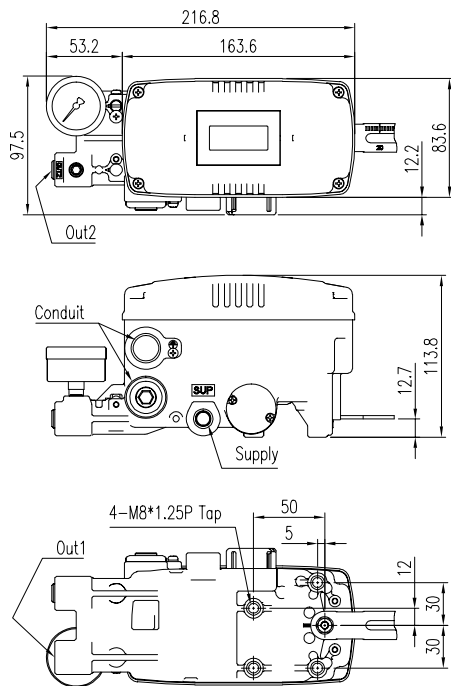

Fig. 2-3: YT-2500L

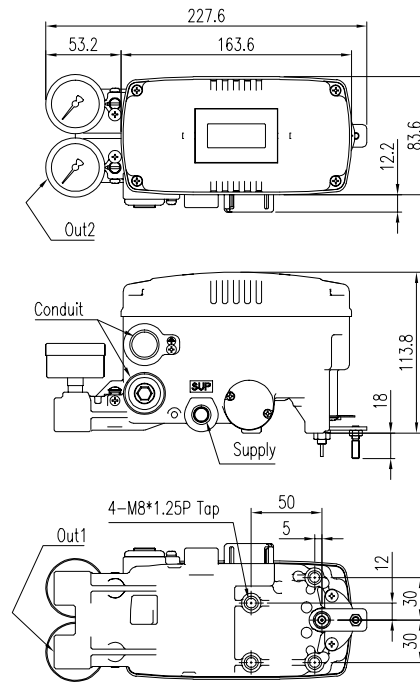

Fig. 2-4: YT-2500R (Fork Lever Type)

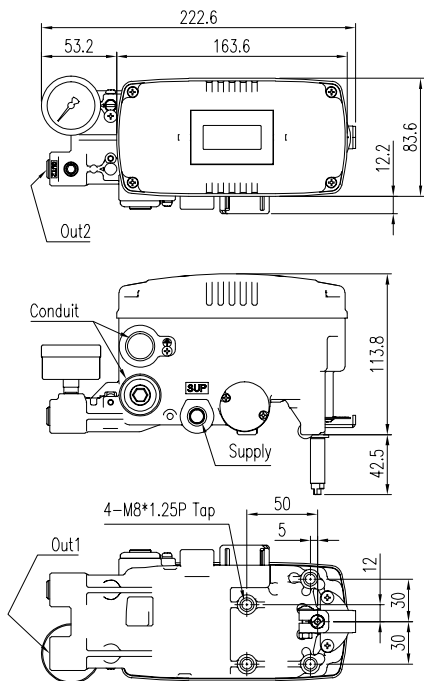

Fig. 2-5: YT-2500R (Namur Type)

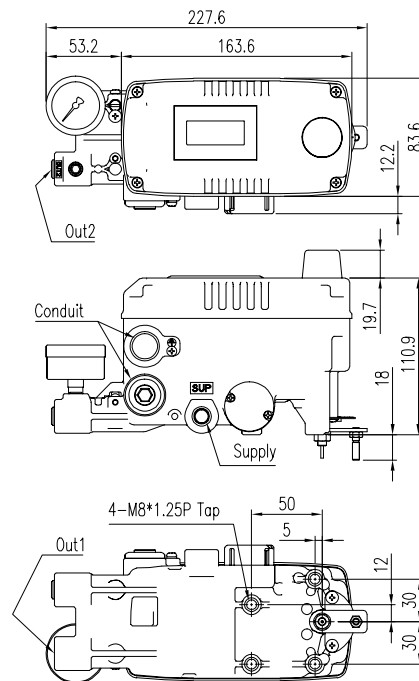

Fig. 2-6: YT-2500R (L/S Option)

2.8.2 YT-2550

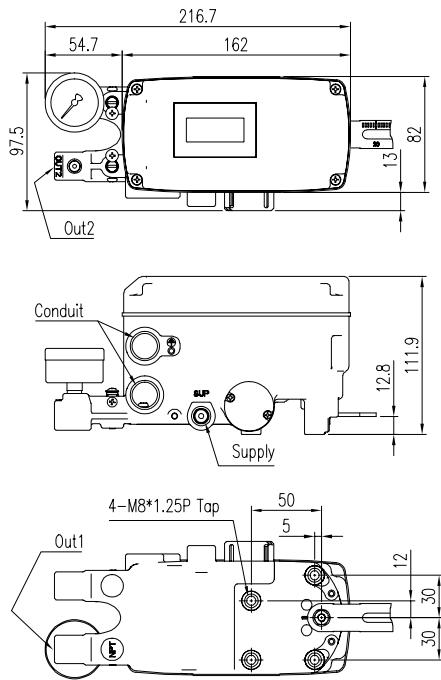

Fig. 2-7: YT-2550L

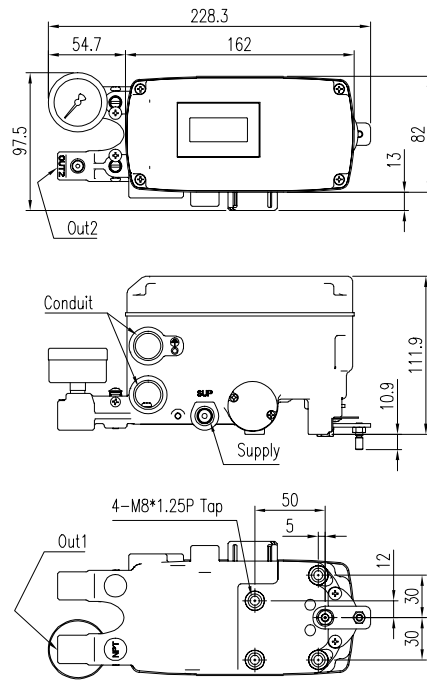

Fig. 2-8: YT-2550R

2.8.3 YT-2501

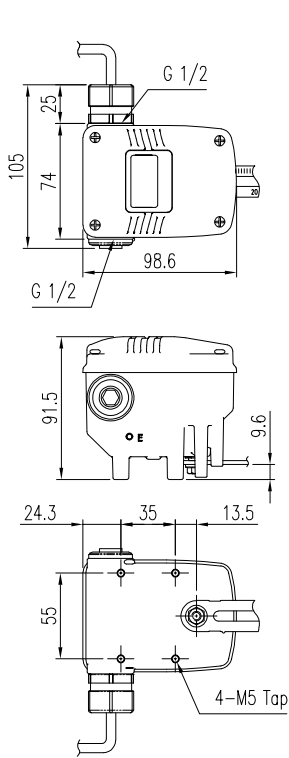

Fig. 2-9: Linear Remote Sensor

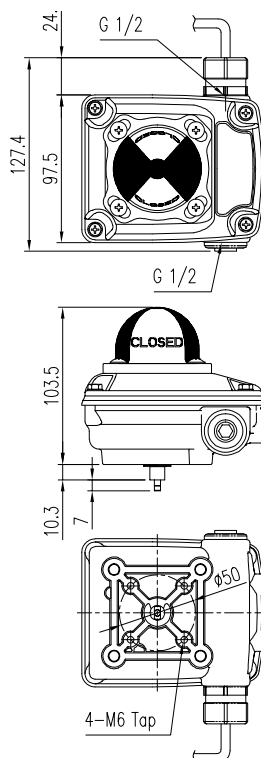

Fig. 2-10: Rotary Remote Sensor

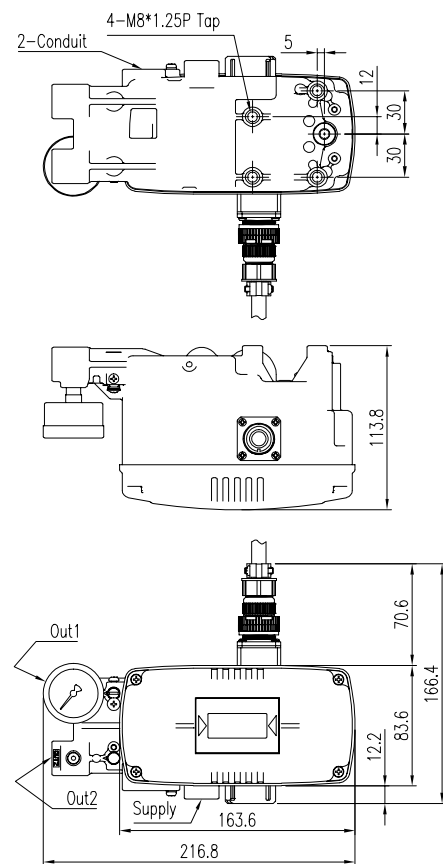

Fig. 2-11: YT-2501 Positioner

3 Installation

3.1 Safety

When installing a positioner, please ensure to read and follow safety instructions.



- Any input or supply pressures to valve, actuator, and / or to other related devices must be turned off.
- Use bypass valve or other supportive equipment to avoid entire system “shut down”.
- Ensure there is no remaining pressure in the actuator.
- The positioner has a vent cover to exhaust internal air and drain internal condensation water. When installing the positioner, make sure the vent cover must be facing downward. Otherwise, the condensation water could cause damages to PCB.

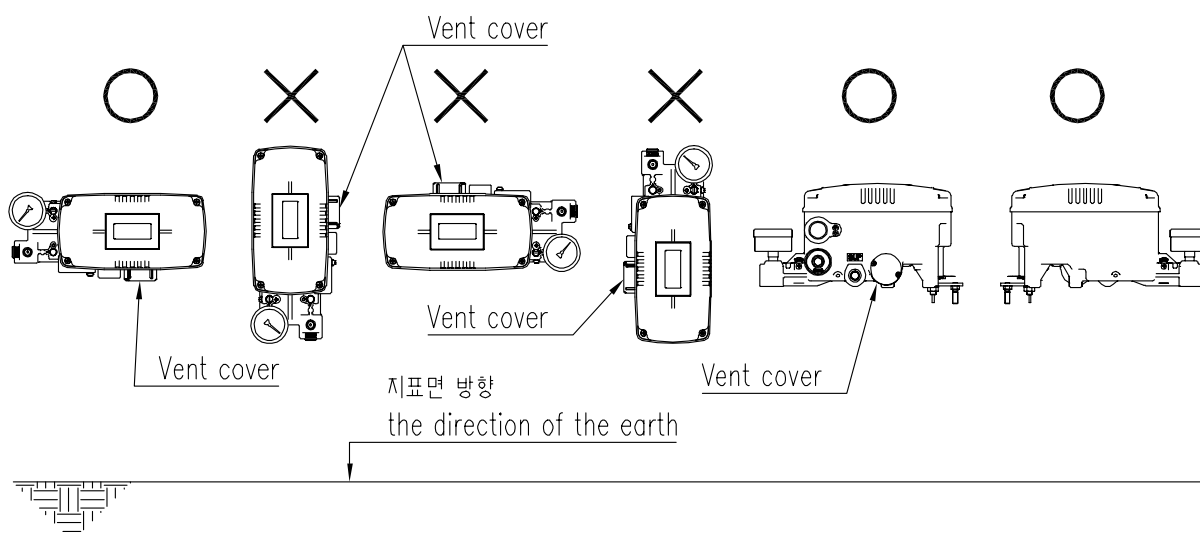

Fig. 3-1: The correct positions of a vent cover

3.2 Tools for installation

- Hex key set for hex socket cap bolts
- (+) & (-) Screw drivers
- Spanners for hexagonal-head bolts

3.3 Linear positioner Installation

Linear positioner should be installed on linear motion valves such as globe or gate type which uses spring return type diaphragm or piston actuators.

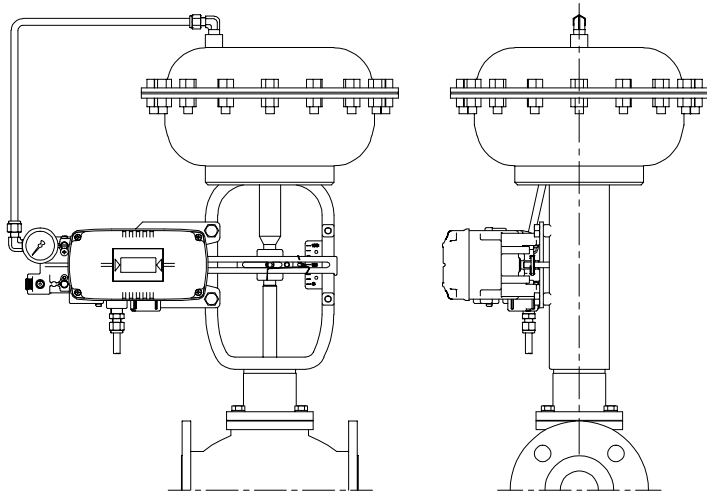

Fig. 3-2: YT-2500L / 2550L installation example

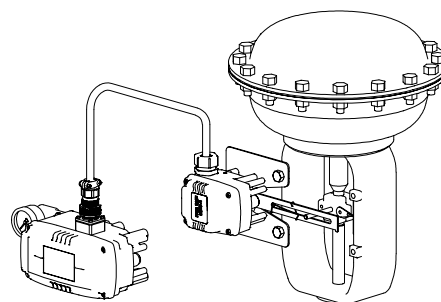

Fig. 3-3: YT-2501L installation example

Before proceeding with the installation, ensure following components are available.

- Positioner
- Linear remote sensor (Only YT-2501)
- Remote cable (Only YT-2501)
- Feedback lever and lever spring
- M6 nut and spring washer (fastening feedback lever to a main shaft)
- Bracket, bolts and washers for positioner or sensor – not supplied with the positioner
- Connection bar – not supplied with the positioner

3.3.1 Safety

Proper bracket must be made in order to adapt the positioner on the actuator yoke.

Please consider following important points when a bracket is being designed.

- Positioner's feedback lever must be vertical to the valve stem at 50 % of the valve stroke.
- The connection bar of the actuator clamp for the feedback lever should be installed in such a way that the valve stroke length coincides with the corresponding figure in "mm" marked on the feedback lever. Improper setting may cause poor linearity



3.3.2 Linear positioner Installation Steps

- 1) Assemble the positioner with the bracket made in previous step by fastening the bolts. The bolt size is M8 x 1.25P.

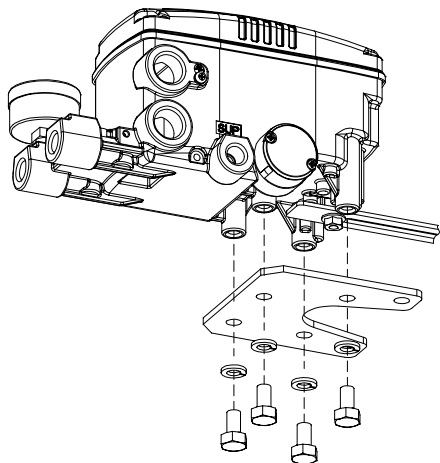

Fig. 3-4: Attaching to bracket

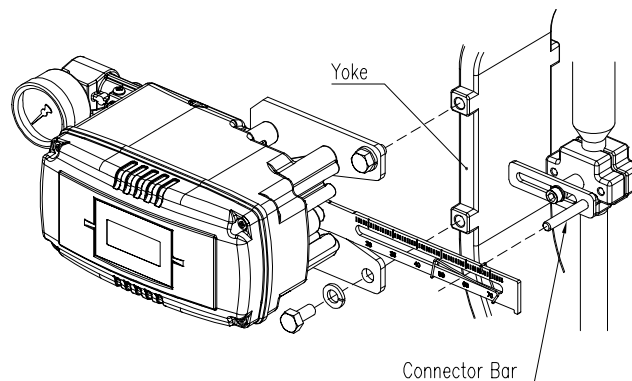

Fig. 3-5: Attaching the bracket to actuator yoke

- 2) Attach the positioner (or remote sensor) with the bracket to the actuator yoke – **DO NOT TIGHTEN THE BRACKET COMPLETELY.**
- 3) Connect connection bar to the actuator clamp. The hole gap on the feedback lever is 6.5 mm so the connection bar's outer diameter should be less than 6 mm.
- 4) Connect an air-filter regulator to the actuator temporarily. Supply enough air pressure to the actuator in order to position the valve stroke at 50 % of the total stroke.

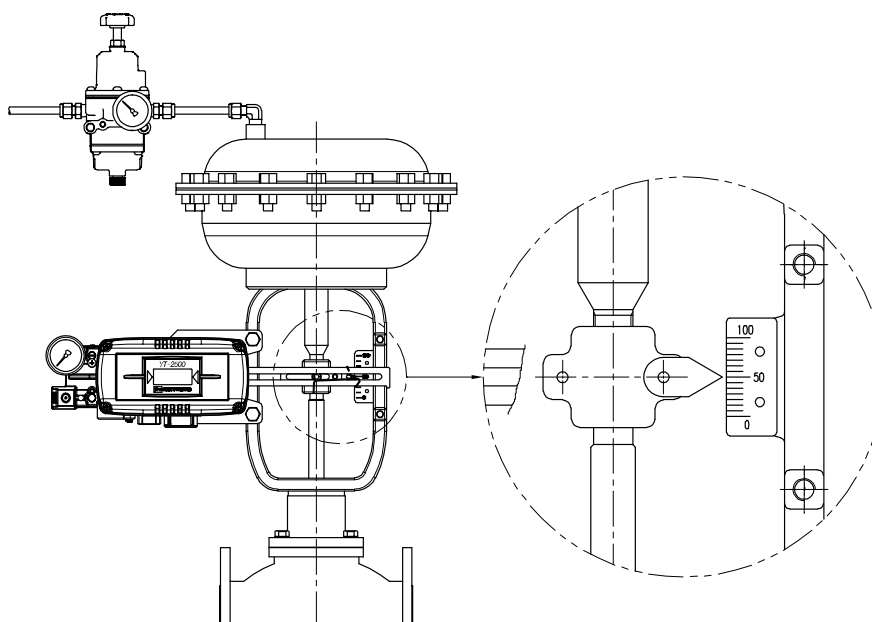

Fig. 3-6: Supplying proper regulated air to the actuator to position the valve at 50 %

- 5) Insert the connection bar between the feedback lever and lever spring. The connection bar must be located upward from the lever spring as shown below left figure. If it is located downward from the lever spring as shown below right figure, the connection bar or the lever spring will be worn out quickly because of excessive strong tension.

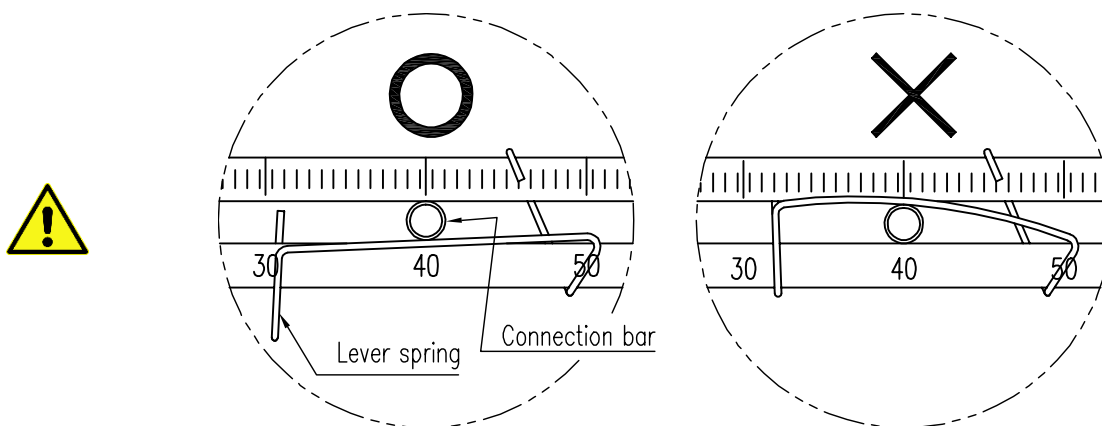

Fig. 3-7: Proper way to insert connection bar between feedback lever and lever spring

- 6) Check if feedback lever is vertical to the valve stem at 50 % of the valve stroke. If it is not vertical, adjust the bracket or the connection bar to make vertical. Improper installation may cause poor linearity.

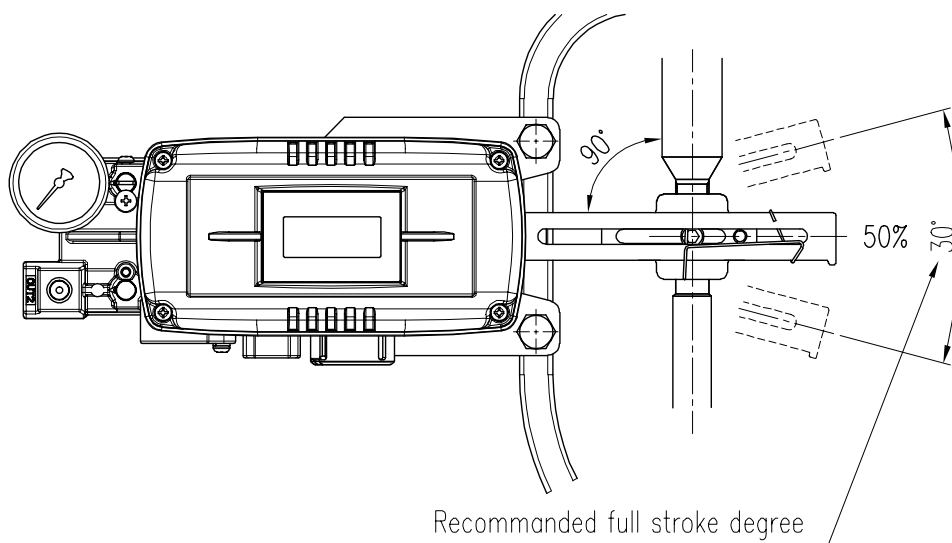

Fig. 3-8: Feedback lever and valve stem

- 7) Check the valve stroke. The stroke numbers are engraved on the feedback lever of the positioner. Position the connection bar at the number on the feedback lever which corresponds with the desired valve stroke. To adjust, move the bracket, the connection bar or both.

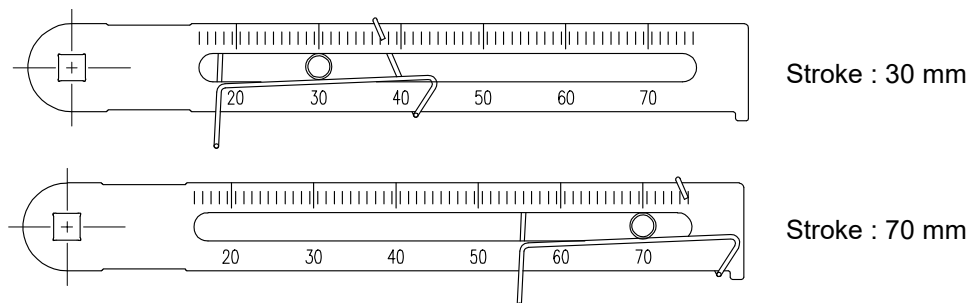

Fig. 3-9: Feedback lever and location of the connection bar

※ The effective linear lever angle of YT-2500 series is 30 degree.



- 8) After installing the positioner, operate the valve from 0 % to 100 % stroke by using direct air to the actuator. On both 0 % and 100 %, the feedback lever should not touch the lever stopper, which is located on the backside of the positioner. If the feedback lever touches the stopper, the positioner should be installed further away from center of the actuator.

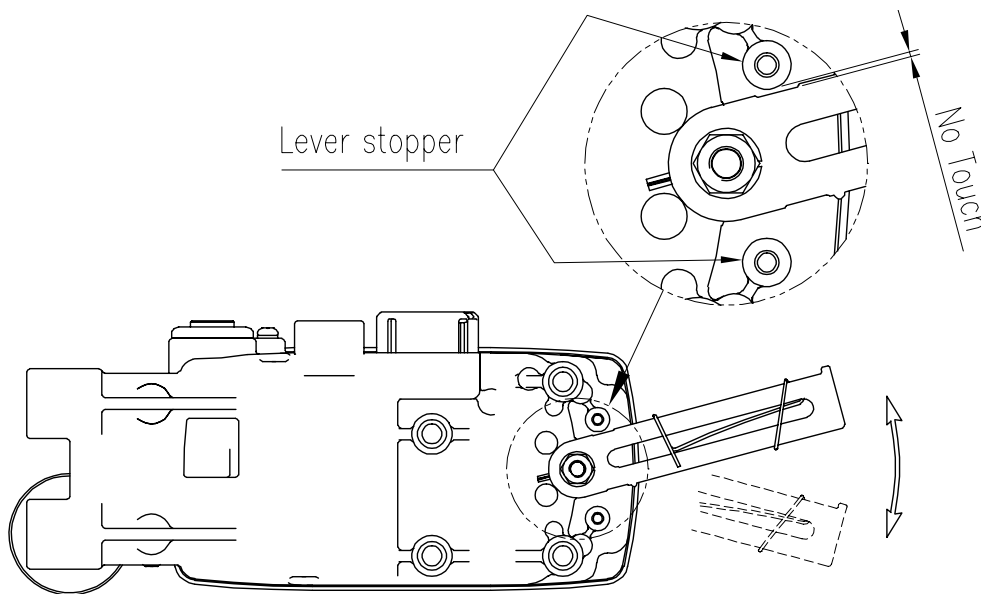

Fig. 3-10: Feedback lever should not touch lever stopper on 0 % to 100 % valve stroke.

- 9) After the installation, tighten all of the bolts on the bracket and the connection bar.

3.4 Rotary positioner Installation

Rotary positioner should be installed on rotary motion valve such as ball or butterfly type which uses rack and pinion, scotch yoke or other type of actuators which its stem rotates 90 degrees. Before proceeding with the installation, ensure following components are available.

3.4.1 YT-2500R / 2550R Components

- Positioner
- Fork lever (Only Fork lever type)
- Rotary bracket set (2 pieces)
- 4 pcs x hexagonal headed bolts (M8 x 1.25P x 15L) : For the positioner and the upper bracket
- 4 pcs x M8 plate washers : For the positioner and the upper bracket
- 4 pcs x wrench headed bolts (M6 x 1P x 15L) : For the brackets
- 4 pcs x M6 nuts : For the brackets
- 4 pcs x M6 spring washers : For the brackets
- Bolts and washers to attach the lower bracket to actuator – not supplied with the positioner

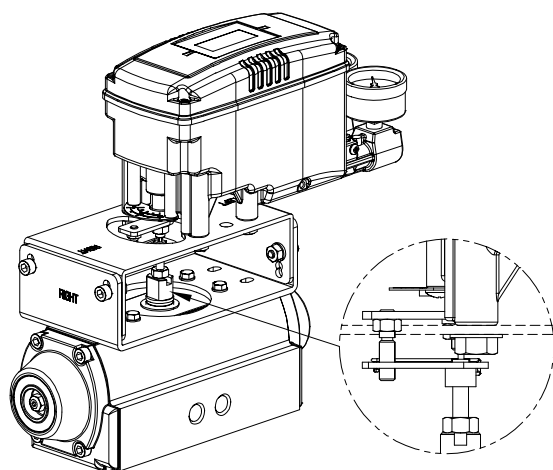

Fig. 3-11: YT-2500R / 2550R Fork lever type

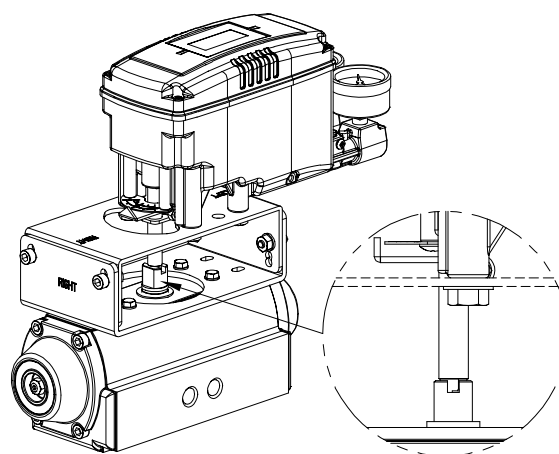

Fig. 3-12: YT-2500R / 2550R Namur type

3.4.2 YT-2501R remote sensor Components

- Rotary remote sensor
- Bracket for actuator stem height 20 mm (1 piece)
- 4 pcs x hexagonal headed bolts (M6 x 1P x 10L)
: For the positioner and the bracket
- 4 pcs x M6 spring washers: For the positioner and the bracket
- 4 pcs x hexagonal headed bolts (M5 x 0.8P x 10L)
: For the bracket and the actuator
- 4 pcs x M6 spring washers : For the bracket and the actuator

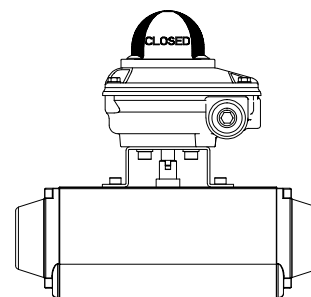

Fig. 3-13: YT-2501R Rotary remote sensor

3.4.3 Rotary Bracket information (Only YT-2500 / 2550)



The rotary bracket set (included with the positioner) contains two components. The bracket is designed to fit onto the actuator with 20 mm, 30 mm and 50 mm stem height (H) according to VDI/VDE 3845 standard. Please refer to below table how to adjust the height of the bracket.

Actuator stem height (H)	Markings of bolt holes			
	A-L	B-L	A-R	B-R
20 mm	H : 20	H : 20, 30	H : 20	H : 20, 30
30 mm	H : 30	H : 20, 30	H : 30	H : 20, 30
50 mm	H : 50	H : 50	H : 50	H : 50

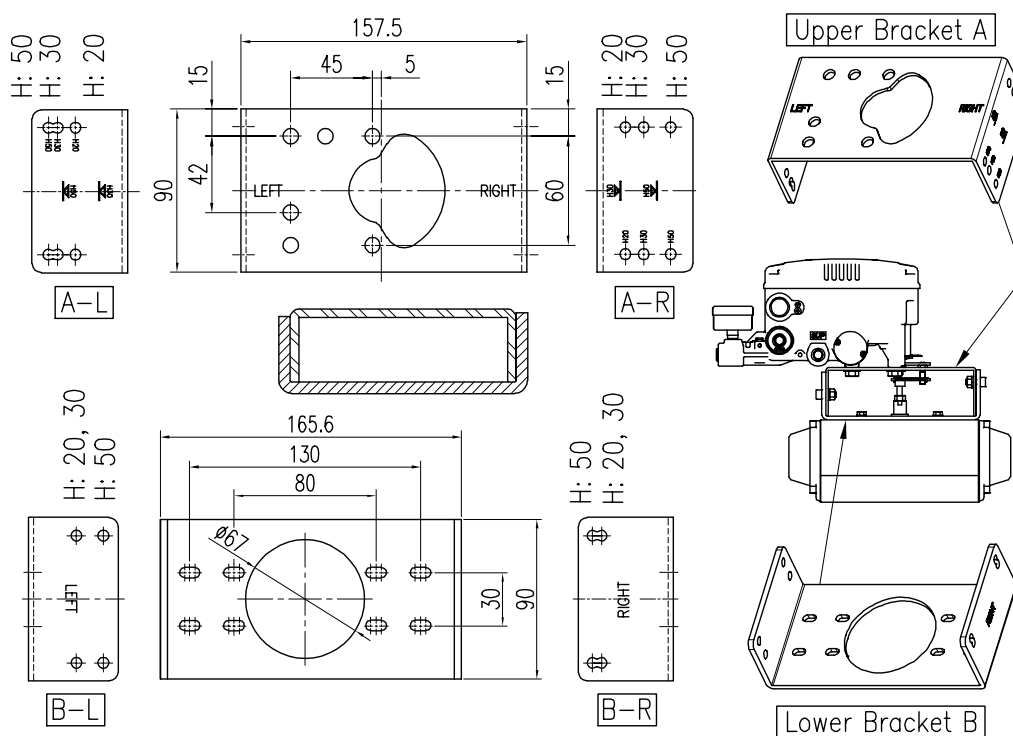

Fig. 3-14: YT-2500R / 2550R Brackets and positioner

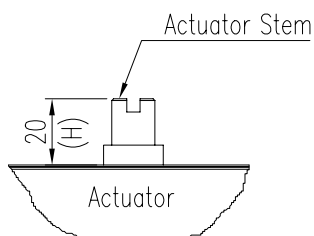

Fig. 3-15: Actuator stem Height

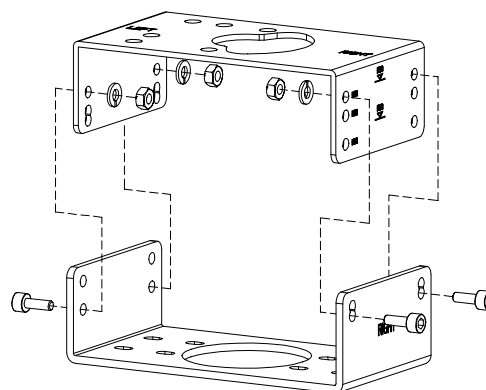

Fig. 3-16: Exploded Brackets

3.4.4 Rotary positioner Installation Steps

- 1) Please check the actuator's stem height and adjust the brackets by referring to the above bracket table.
- 2) Attached the brackets onto the actuator. It is recommended to use spring washer so the bolts will not be loosen from vibration.
- 3) Set rotation position of the actuator stem at 0 %. For single acting actuator, it is easy to check 0 % point by supplying no pressure to the actuator. For double acting actuator, check actuator stem's rotation direction – clockwise or counter-clockwise - by supplying pressure to the actuator.
- 4) (Only Fork lever type of YT-2500 / 2550) Install the fork lever after setting actuator's stem at 0 %. Check the actuator stem's rotation direction – clockwise or counter-clockwise. Installation angle of the fork lever should be 45° to the longitudinal direction of the actuator.

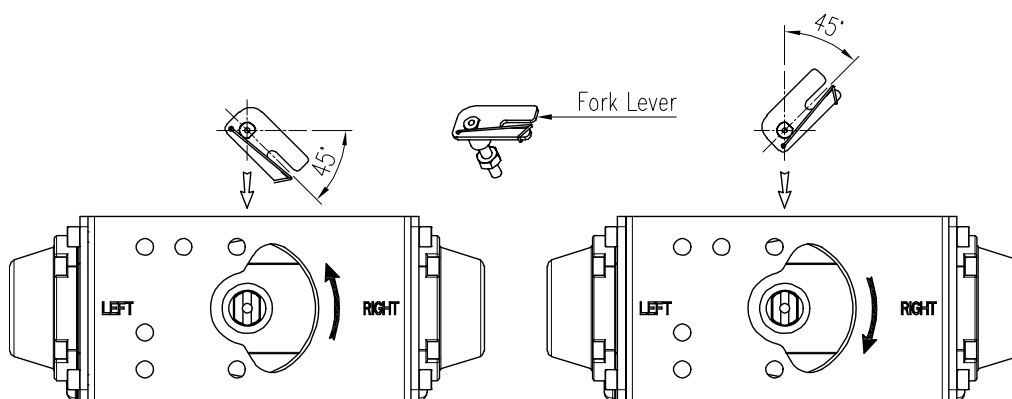

Fig. 3-17: Counter-clockwise and clockwise rotation.

- 5) (Only Fork lever type of YT-2500 / 2550) After setting fork lever position, fasten lock nuts which are located on the bottom of the fork lever. Ensure to set the gap between the top of upper bracket and the top of the fork lever within **6 to 11 mm**.

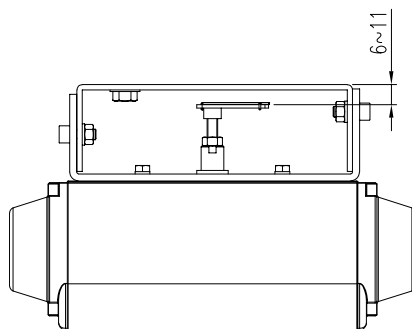

Fig. 3-18: Height to the bracket (fork lever type)



- 6) Attach the positioner to the bracket. *<Only fork lever type of YT-2500 / 2550: Fix the clamping pin (5 mm Dia.) into the fork lever slot and insert center pin (2 mm Dia.) of the main shaft of the positioner into the hole of center of the fork lever. The clamping pin will be locked to the fork lever spring.>* Setting alignment of center of main shaft of the positioner and center of the actuator's stem is very important. Poor alignment of the main shaft and the actuator's stem decreases the positioner's durability due to unnecessary forces on the main shaft.

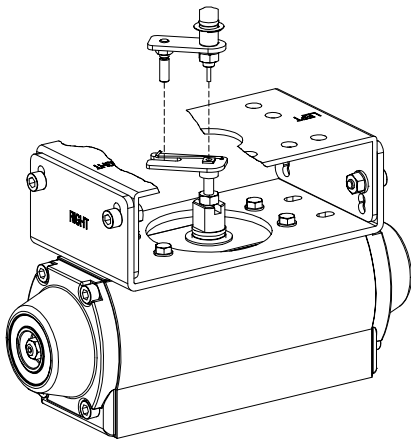

Fig. 3-19: Main shaft center alignment (Fork lever)

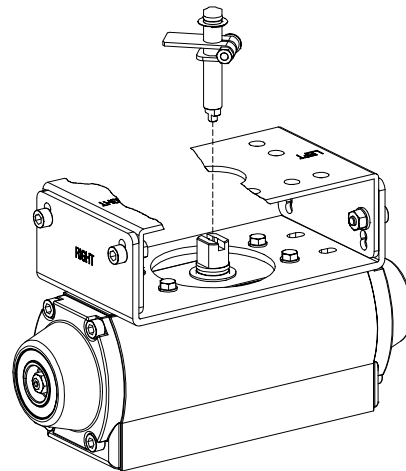

Fig. 3-20: Main shaft center alignment (Namur)

- 7) Tighten the positioner and the bracket with bolts **after checking the positioner's position.**

4 Connection - Air

4.1 Safety

- Supply pressure should be clean and dry air – avoiding moisture, oil and dust.
- Always recommended to use air filter regulator (i.e. YT-200 series).
- Rotork YTC Limited **has not tested positioner's operation with any other gases other than clean air. Please contact Rotork YTC Limited for any questions.**

4.2 Supply Pressure Condition



- Dry air with dew point of at least 10 °C lower than ambient temperature.
- Avoid from dusty air. Use 5 micron or smaller filter.
- Avoid oil.
- Comply with ISO 8573-1 or ISA 7.0.01.
- Supply pressure range is 0.14 to 0.7 MPa (1.4 to 7 bar)
- Set air filter regulator's pressure level 10% higher than actuator's spring range pressure.

4.3 Piping Condition



- Ensure inside of pipe is clean of obstructions.
- Do not use pipeline that is squeezed or shows any type of damamges.
- Pipeline should have more than 6 mm of inner diameter (10 mm outer diameter) to maintain flow rate.
- The length of pipeline system should not be extremely long. Longer pipeline system may affect flow rate due to the friction inside of the pipeline.

4.4 Connection – Piping with actuator

4.4.1 Single acting actuator

Single acting type positioner is set to use only OUT1 port. OUT1 port of positioner should be connected with supply port of actuator when using spring return actuator of single acting type.

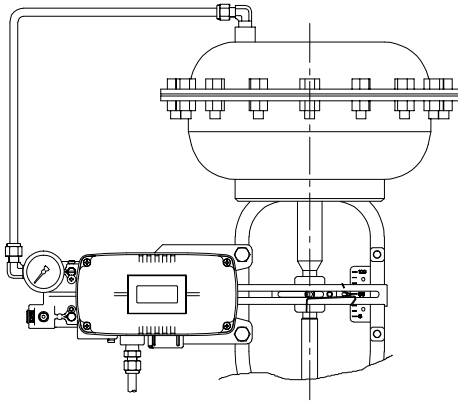

Fig. 4-1: Single acting linear actuator (YT-2500L / 2550L)

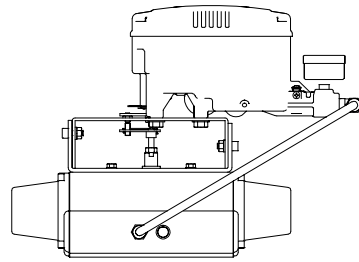

Fig. 4-2: Single acting rotary actuator (YT-2500R / 2550R)

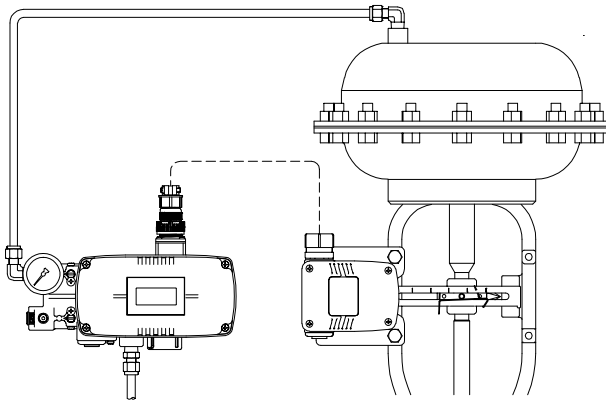

Fig. 4-3: Single acting linear actuator (YT-2501L)

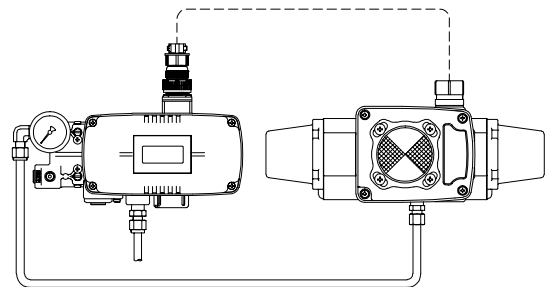

Fig. 4-4: Single acting rotary actuator (YT-2501R)

4.4.2 Double acting actuator

Double acting type positioner is set to use OUT1 and OUT2 port. As input signal increases, the supply pressure will be supplied through OUT1 port.

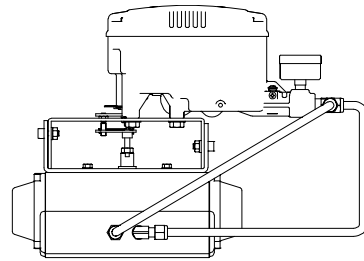
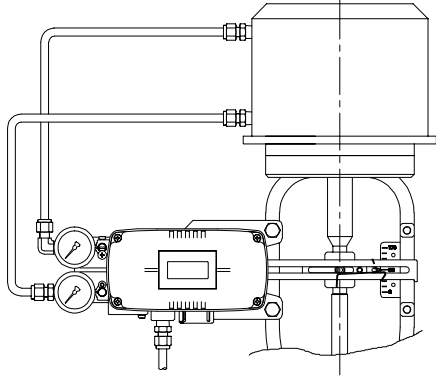

Fig. 4-5: Double acting linear actuator (YT-2500L / 2550L) Fig. 4-6: Double acting rotary actuator (YT-2500R / 2550R)

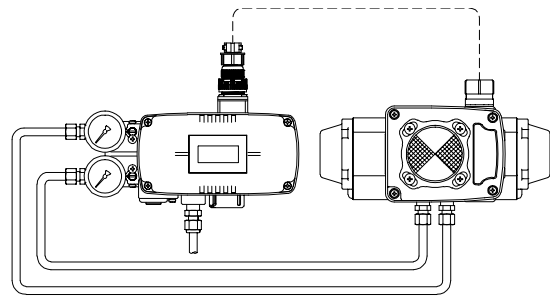
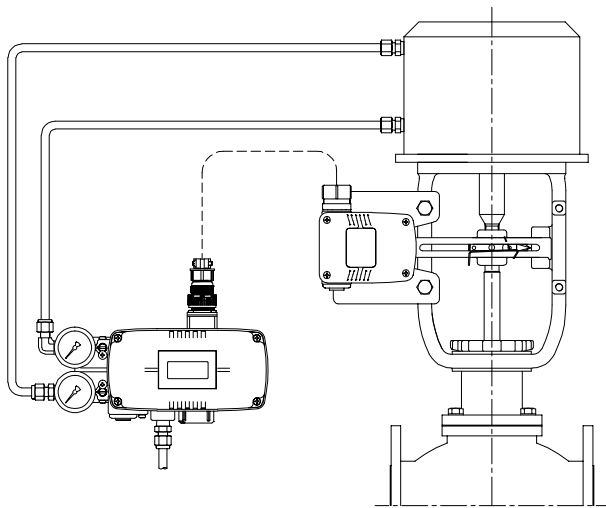

Fig. 4-7: Double acting linear actuator (YT-2501L)

Fig. 4-8: Double acting rotary actuator (YT-2501R)

5 Connection – Power

5.1 Safety



- There are two conduit entries on the product. See “2.4 Product Code” for conduit entry threads.
- Before connecting terminal, ensure that the power is off completely.
- Please use ring terminal to protect against vibration or any other external impact.
- Positioner usually uses 4-20 mA DC. Minimum ampere of input signal of standard type positioner is 3.5 mA and HART option positioner’s minimum ampere of input signal is 3.8 mA but maximum ampere of input signal should be 24 mA or under.
- Compliance voltage of current source must be Min. 10 V and Max. 28 V. If the length of the supply cable between the current source and the positioner is long, or if there is a filter or safety barrier, then consider using a current source which could supply higher Compliance voltage.
- Positioner with 4-20 mA Analog Output option must be supplied with **9 to 28 V DC** separately. For mechanical limit switch option, separate **12 to 30 V DC** must be supplied. For inductive proximity limit switch option, separate **8.2 V DC** must be supplied.
- **DO NOT connect Voltage source (9 to 28 V DC) to Input (4-20 mA DC) terminal (IN+, IN-) as it will cause PCB failure.**
- Positioner should be grounded.
- Please use twisted cable with conductor section are 1.25 mm² and that is suitable for 600 V (complying with the conductor table of NEC Article 310). The outer diameter of the cable should be between 6.35 to 10 mm. Use shield wire to protect against electro-magnetic field and noise.
- Please do not install the cable near high noise equipment, such as high-capacity transformer or motor.

5.2 Connection

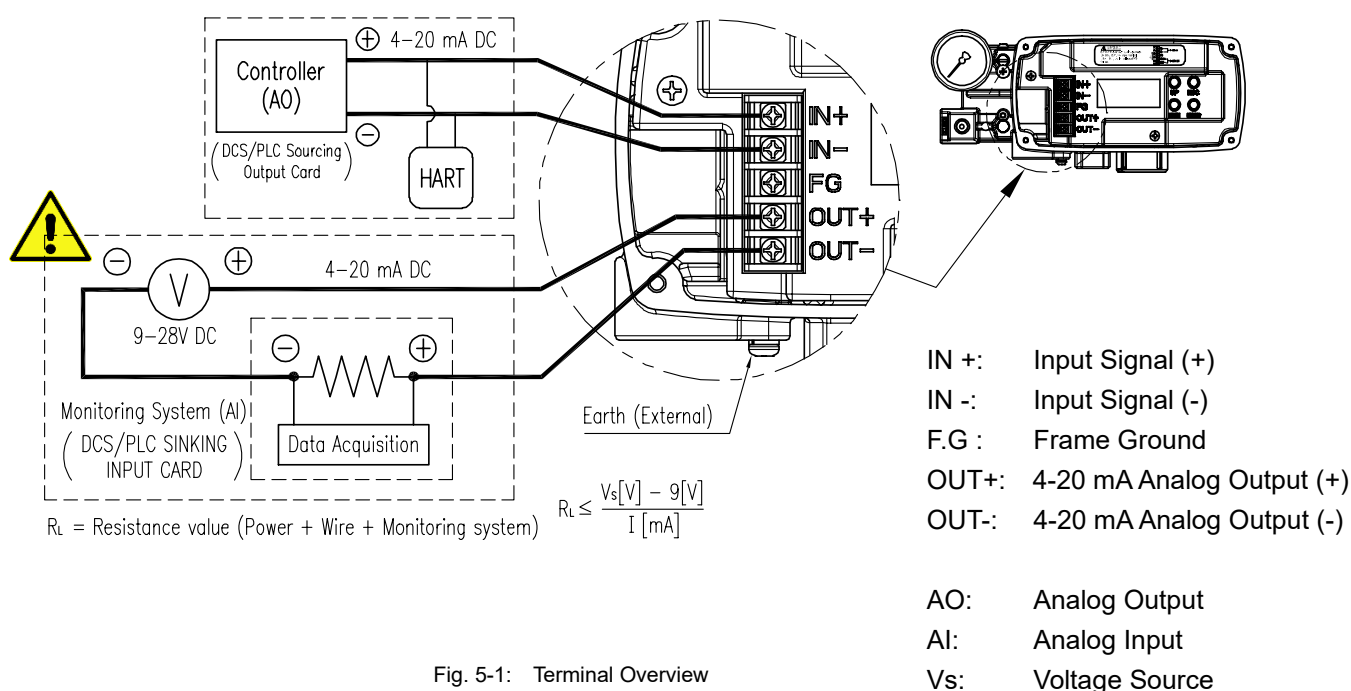

Fig. 5-1: Terminal Overview

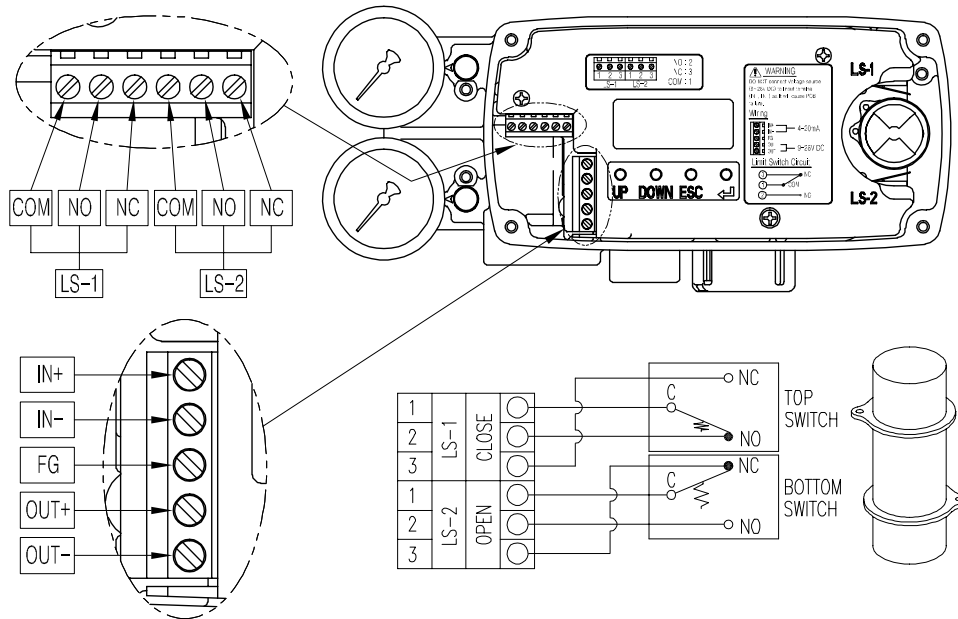

Fig. 5-2: Terminal of two Mechanical Limit Switches (Only YT-2500 / 2550)

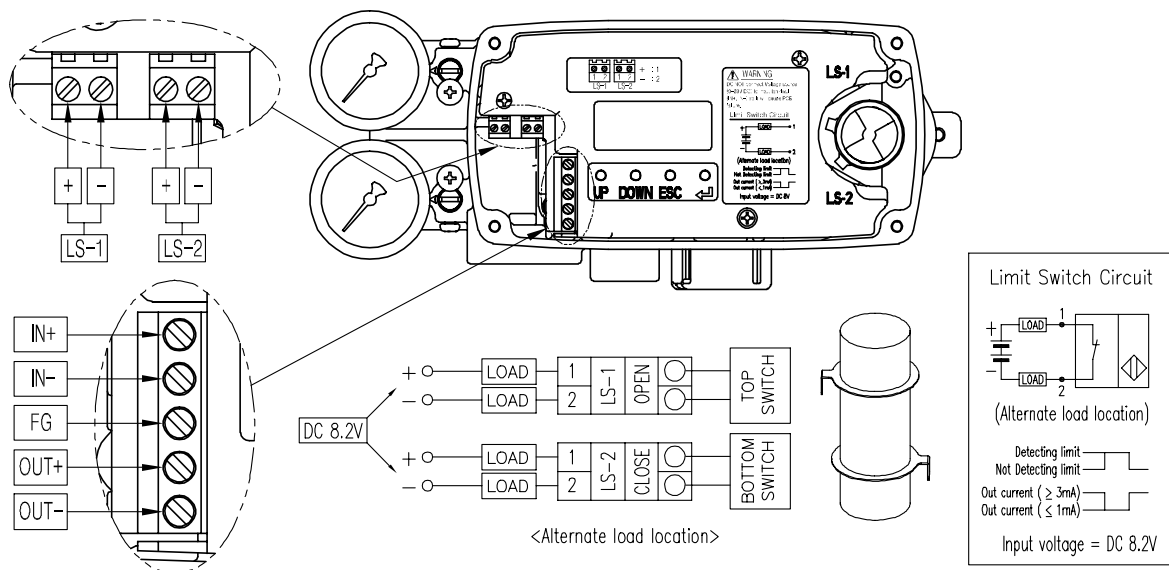

Fig. 5-3: Terminal of two Inductive Proximity Limit Switches (Only YT-2500 / 2550)

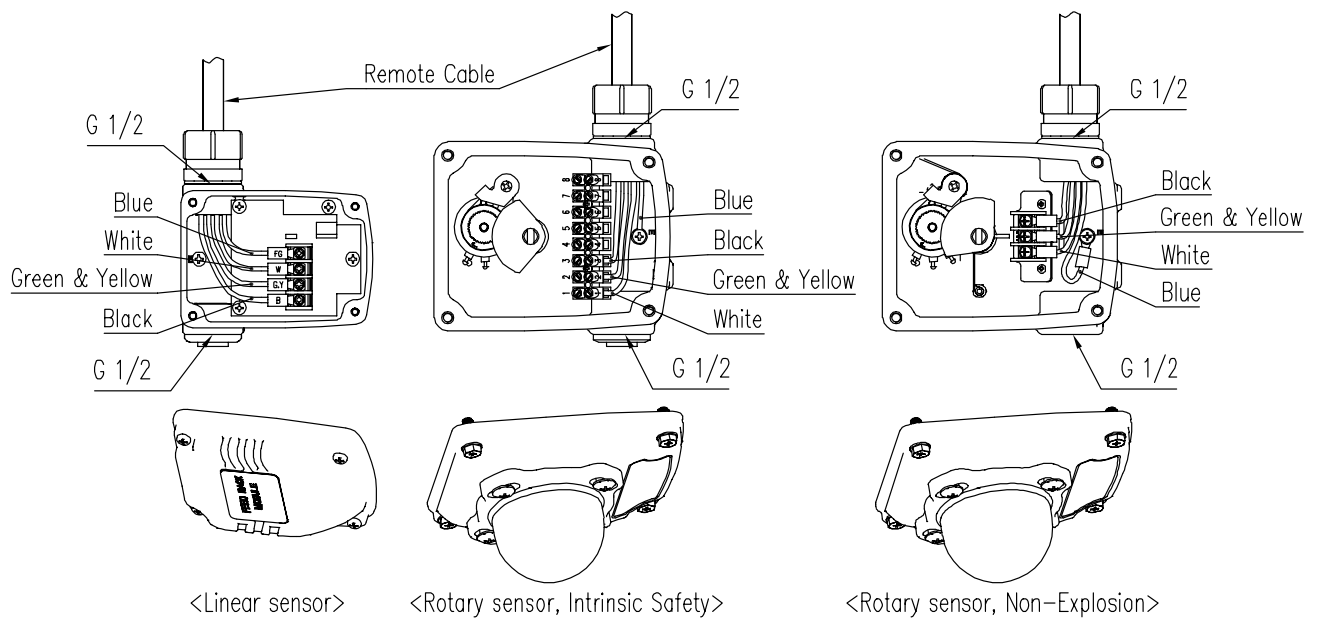

Fig. 5-4: Remote sensor and cables (Only YT-2501)

5.3 Ground

- 1) Ground must be done before operating the positioner.
- 2) Open base cover and there is an internal ground "F.G" on the left hand.
An external ground bolt is located next to the conduit entry. Please make sure that the resistance is less than 100 ohm.

6 Adjustments

6.1 Limit Switch Adjustment

YT-2500 / 2550 can have limit switch option. If user wants to adjust the sensing positions, please loosen bolts and adjust cam.

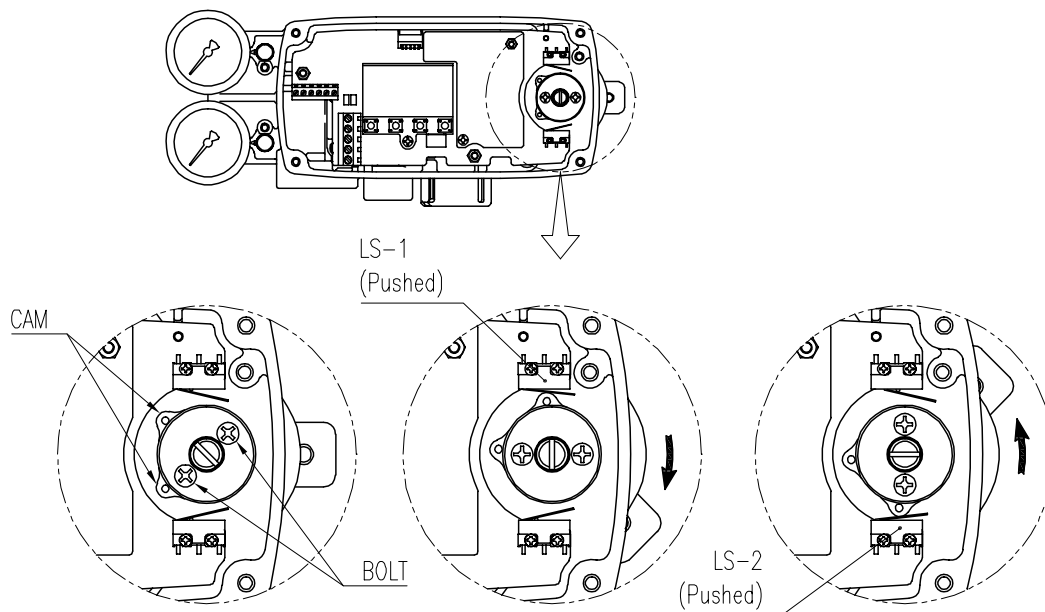

Fig. 6-1: Mechanical Type

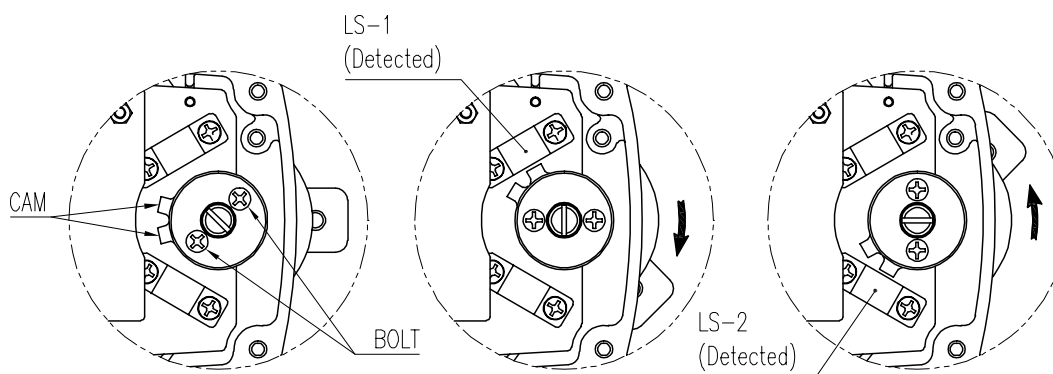

Fig. 6-2: Inductive proximity Type

6.2 Variable Orifice Adjustment

Hunting can be occurred when the actuator's volume is too small. In order to prevent hunting, orifice can be adjusted. By adjusting the orifice, the flow rate of the supply pressure to actuator can be adjusted. Please use (-) driver to adjust the orifice. When slot (-) of the orifice is horizontal, the flow rate becomes maximum. When slot (-) of the orifice is vertical, the flow rate becomes minimum.

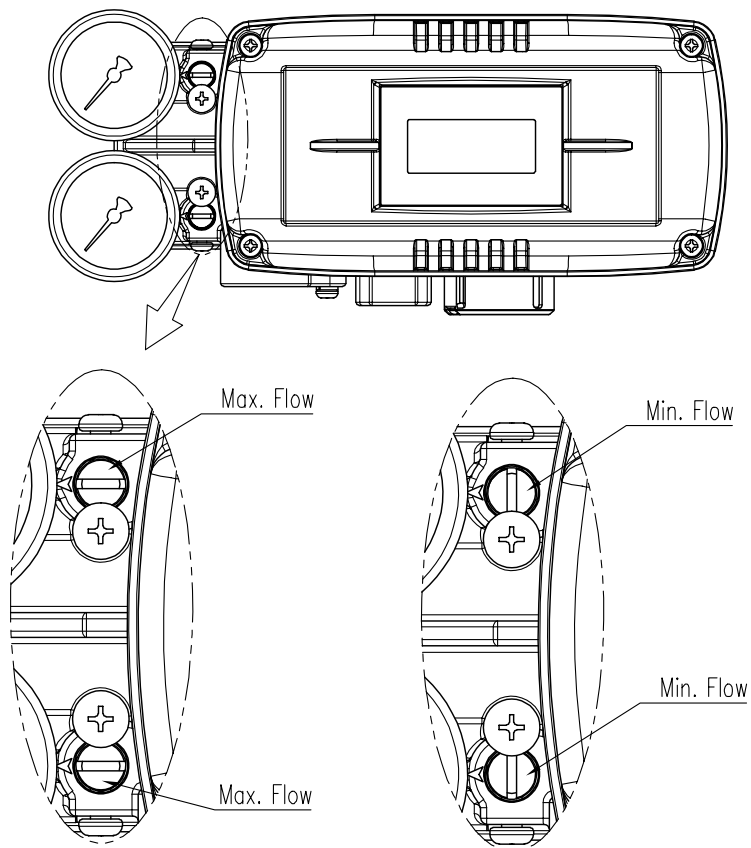

Fig. 6-3: Variable orifice adjustment

7 Optional Sub-PCB Installment

By adding sub-PCB, the positioner can have additional functions. There are 3 types of sub-PCB.

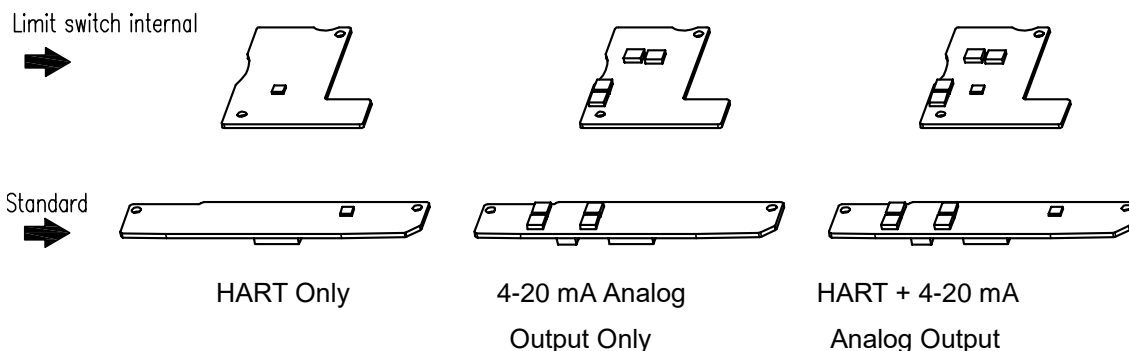

Fig. 7-1: Types of Sub-PCB

When purchasing option sub-PCBs separately, 4 Bolts and 2 supports (3 at Limit switch internal option) are supplied together with sub-PCB.

7.1 Installation steps

- 1) Open base cover, PCB cover. Separate the Main PCB from base body.
- 2) Mount 2ea of sub-PCB support on Main PCB with 2ea of bolt.
- 3) Insert connector of sub-PCB into connector of main PCB correctly.
- 4) Fasten sub-PCB with the rest of bolts or Pcb cover support.

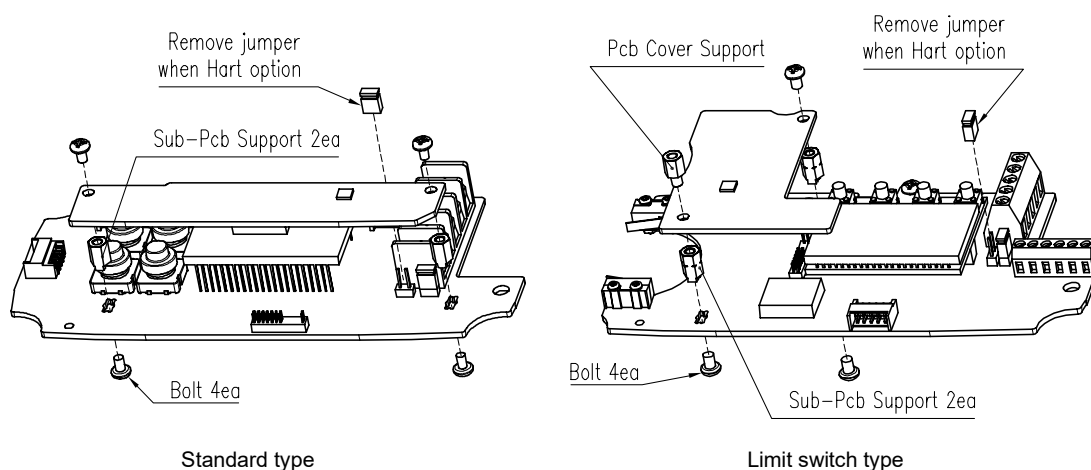

Fig. 7-2: Installation of Optional sub-PCB on Main PCBs



JP1 jumper must be removed, when HART option included sub-PCB is being mounted.

- 5) After 4-20 mA Analog Output sub-PCB is installed newly, values of TR_ZERO and TR_END must be calibrated for correct output signals. For the calibration of TR_ZERO and TR_END, please refer to section 9.7.2 of this manual.

8 Maintenance

8.1 Supply air

If Supply air pressure is not stable or Supply air is not clean, the positioner may not function properly. Air quality and pressure should be checked regularly to see if the air is clean and pressure set is normal.

8.2 Seals

Once a year, it is recommend to check if there are any damaged parts of the positioner. If there are damaged rubber parts such as diaphragms, o-rings and packings, replace with new ones.

9 Auto Calibration and Operation

9.1 Warning



- **Auto Calibration must be performed after the valve and positioner are installed in the facility/process during the commissioning phase or when the positioner is dismantled and then newly mounted on the actuator.**
- **Since the Auto Calibration moves the valve and actuator, the valve must be isolated from the process before Auto Calibration to avoid process interruption.**

9.2 Button Description

Positioner has 4 buttons, and they enable to perform various functions.

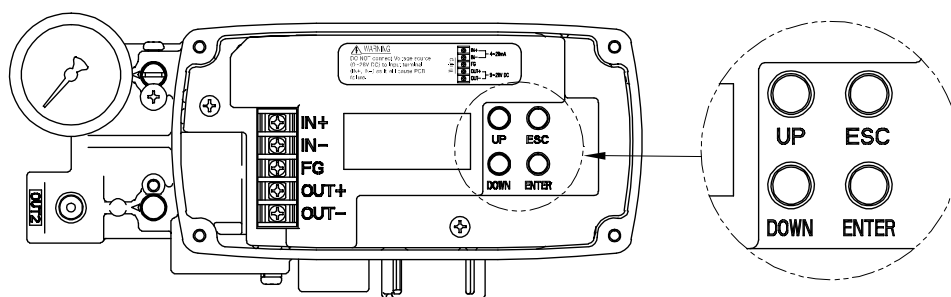

Fig. 9-1: Standard type

<UP> & <DOWN>: Move to next menu, and adjust.

<ENTER, ↵>: Enter to main and sub menus, and save

<ESC>: Return to previous menu

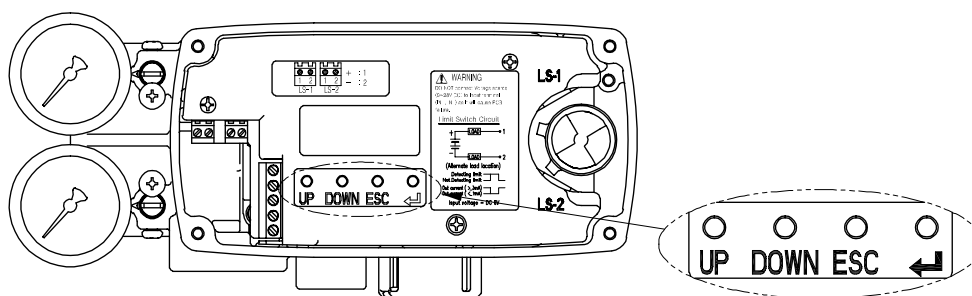
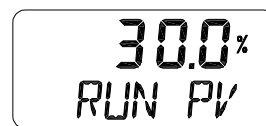

Fig. 9-2: Limit switch type

9.3 Run Mode (RUN)

After power connection to the positioner, Run Mode will be appeared on positioner’s LCD screen in about 4 seconds. “RUN” indicates that the positioner adjusts the valve stroke according to the receiving signal. There are six types of display message in “RUN” Mode.



- 1) Run PV (%): Process Value - valve stroke
- 2) Run SV (%): Set Value – input signal 0 to 100 %
- 3) Run SV (mA): Set Value – input signal 4-20 mA
- 4) Run MV: Manipulate Value – Motor Manipulate Value (Digit)
- 5) Run VEL: Velocity – Current valve stem’s velocity (Digit)
- 6) Run ERR (%): Error – Difference between SV and PV

To change display, Press and hold <ESC>, press <DOWN> several times until a desired display appears. The display will change in the order indicated above. If <ESC> + <UP> pushed, the order will be appeared in opposite order. By pressing <ESC>, the display will return to “RUN PV” mode.

※ Please note that the screen will return to “RUN PV” mode if 100 seconds elapse from the last button pressed.

※ By pressing <ESC> button several times from any MODES, it will return to “RUN PV” mode. Therefore, if the users have entered into wrong modes by mistake or do not wish to proceed with their current work, they could return to “RUN PV” mode.

9.4 Auto Calibration mode (AUTO CAL)

Auto Calibration mode (AUTO CAL) automatically calibrates the positioner. “AUTO CAL” process takes about 2 to 3 minutes, and the duration of the process varies upon the size of the actuator. There are 3 types of AUTO CAL.

	Zero Point	End Point	Dead Zone, P, D	RA / DA
AUTO 1	O	O	X	X
AUTO 2	O	O	O	O
AUTO 3	X	X	O	O



It is recommend to perform AUTO2 calibration for initial positioner setting.

9.4.1 AUTO1 Calibration (AUTO1)

AUTO1 changes only zero and end points; however other parameters(P, D etc.) will not be adjusted. It is recommended to perform AUTO1 when the positioner has been set by the valve manufacturer already, and the field user wants to re-calibrate the positioner.

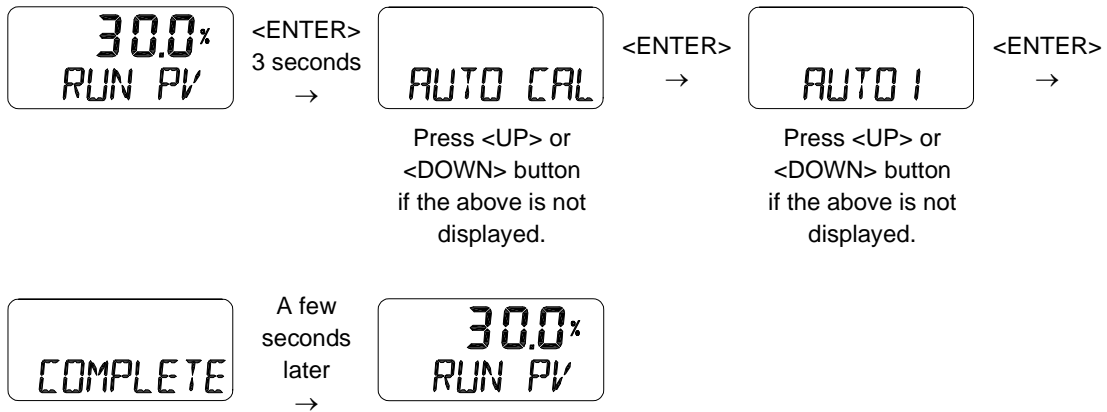

9.4.2 AUTO2 Calibration (AUTO2)

AUTO2 changes all of the parameters. It is recommended to perform AUTO2 when the positioner has been installed on the valve for the first time or the positioner has been reinstalled after disassemble from an actuator.

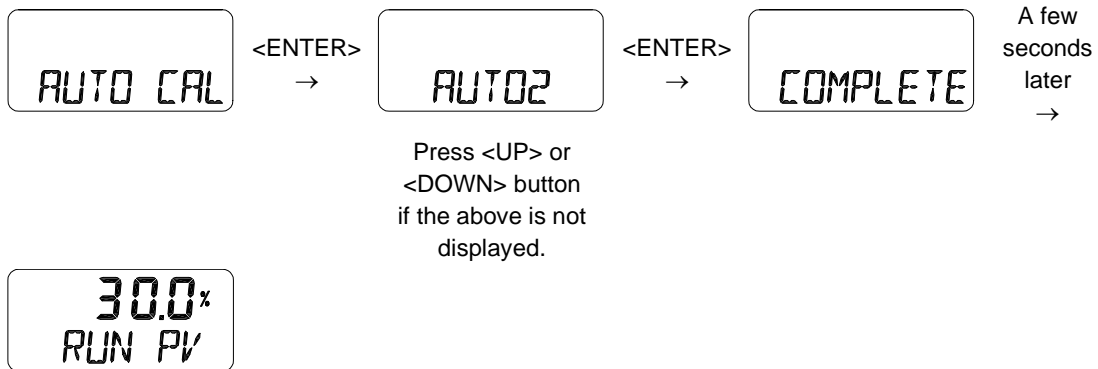

9.4.3 AUTO3 Calibration (AUTO3)

AUTO3 changes other parameters except zero and end points.

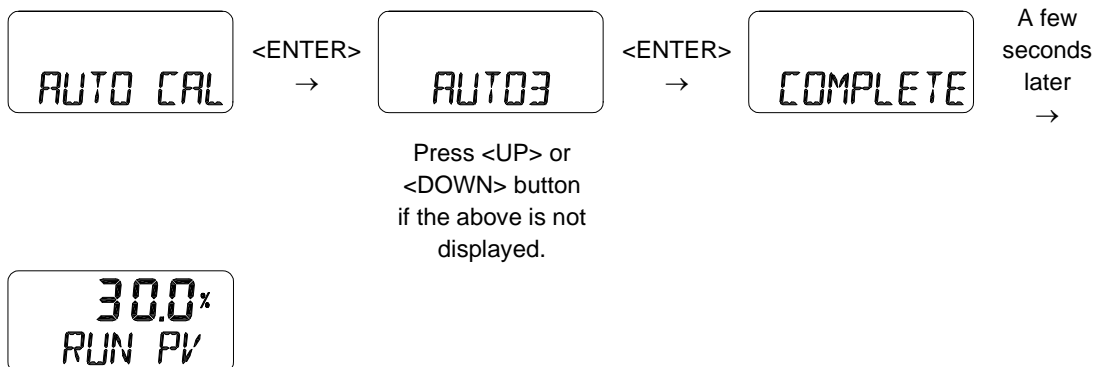

9.5 Manual Mode (MANUAL)

Manual mode is used to maneuver valve stem manually. In Manual mode, the positioner does not control the valve by the signal received from outside, but it could be controlled to move up and down by pressing <UP> and <DOWN> button.

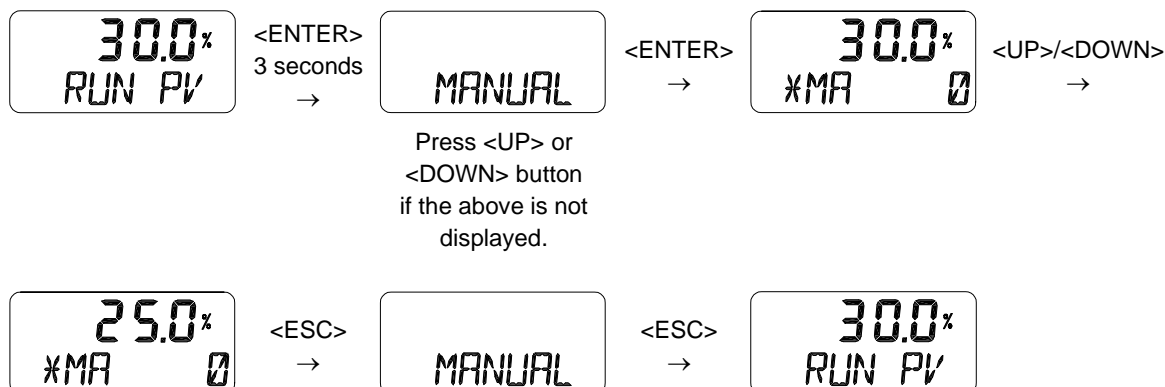

9.6 Parameter Mode (PARAM)

AUTO CAL optimizes most of the valve actuator control values. However, in some instances, hunting or oscillation may occur when the valve actuator control values are not optimized. Hunting or oscillation can be prevented by adjusting parameter values.



If you change the parameter values with <UP> <DOWN> buttons, the changed value is immediately applied to the positioner control. When the desired control status is reached, you must press <ENTER> button to save the values.

Below are the list of features which could be set from Parameter mode.

- 1) Dead-Zone (dEAdZONE)
- 2) P1 Value (KP1)
- 3) D1 Value (Kd1)
- 4) P2 (KP2) and D2 (Kd2) values
- 5) P_ (KP_) and D_ (Kd_) Values
- 6) PT1 (PT1) and PT2 (PT2) Values
- 7) Period T (PERIOd T)
- 8) Auto DZ (AUTO dZ)

9.6.1 Dead-Zone (dEAdZONE, %)

Dead-Zone indicates the percentage of error allowance. When AUTO 2 or AUTO 3 calibration are done, this value would be set automatically and moderately. But if hunting still occur after AUTO 2 or AUTO 3 calibration for the reason such as high level of packing friction, increasing the value of Dead-Zone can stable the valve operation.

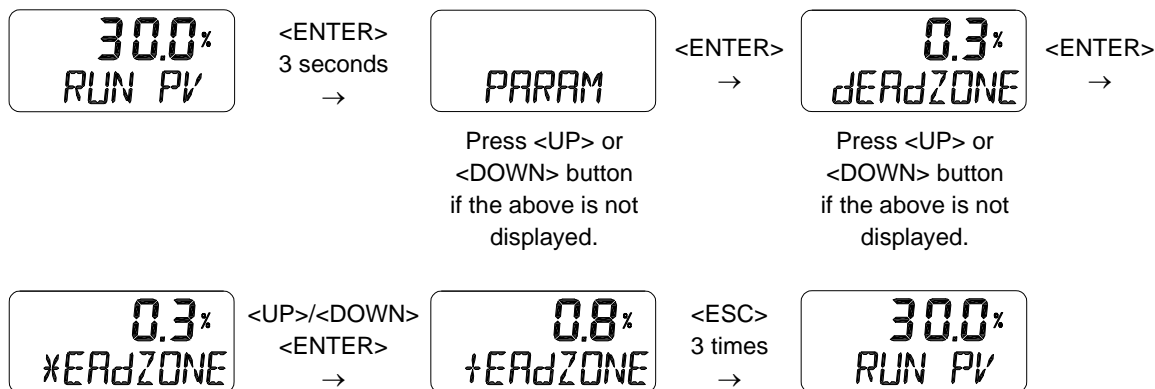

9.6.2 P1 Value (KP1)

P value indicates the ratio of the compensation signal based on the percentage of error allowance. As the value increase, the positioner finds the target point quickly, but it is more likely to have hunting. As the value decrease, the stability of the positioner is higher, but it finds the target point slowly. But these values are applicable for only when input signal is increasing.

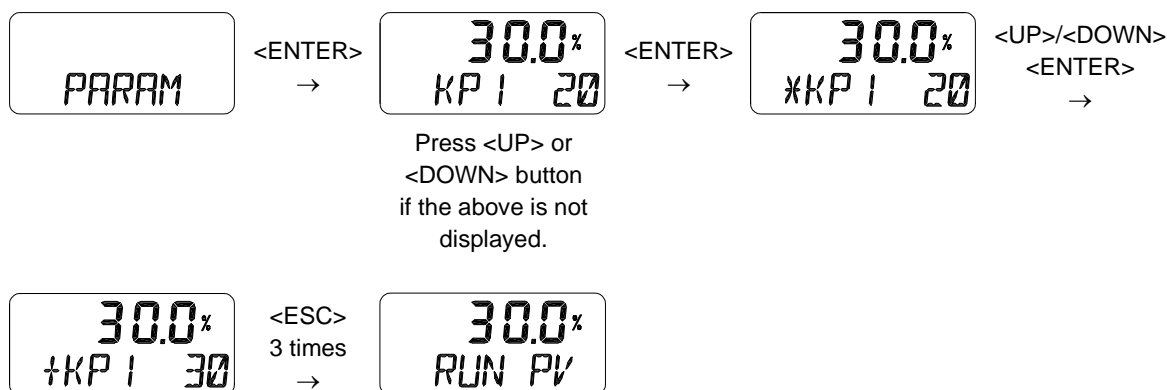

9.6.3 D1 Value (Kd1)

D value indicates the derivative value of the compensation signal based on the percentage of error allowance. As the value increase, it is more likely to have hunting. As the value decreases, it can have poor linearity or dynamic characteristic. but these values are applicable for only when input signal is increasing.

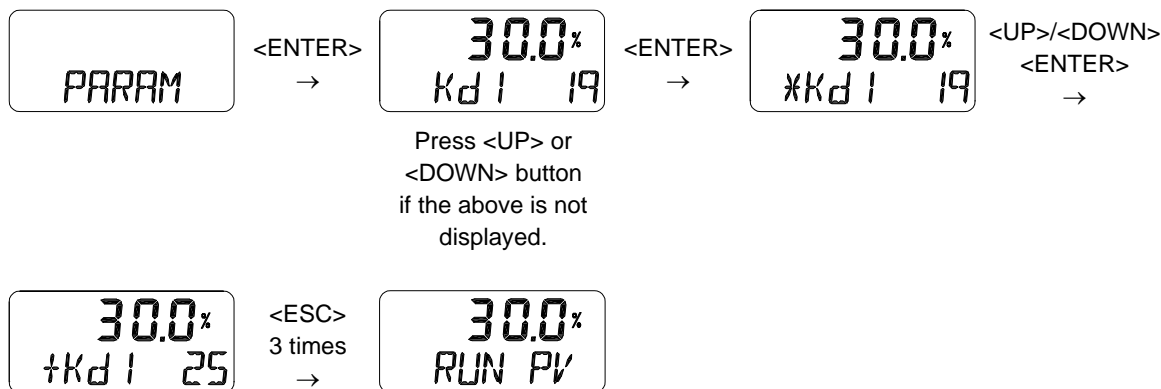

9.6.4 P2 (KP2) and D2 (Kd2) values

P2 and D2 values' principles are same as P1 and D1, but these values are applicable for only when input signal is decreasing.

9.6.5 P_ (KP_) and D_ (Kd_) Values

P_ and D_ values' principles are same as P and D values, but these values will be activated when the error percentage of the actual stroke per input signal reaches within 1 %.

9.6.6 PT1 (PT1) and PT2 (PT2) Values

PT value indicates the minimum time duration(unit: 0.1 mSec) of internal signal controlling pilot valve. PT1 is for increased input signal, and PT2 is for decreased input signal's PT values.

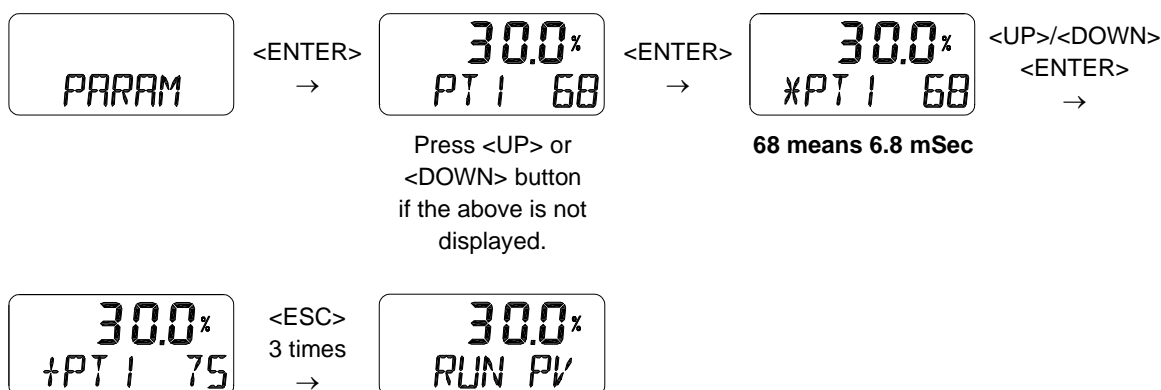

9.6.7 Period T (PERIOd T)

Period T indicates the positioner's internal control time interval. As default, positioner will check current position respective to current input signal in every 100 msec.

9.6.8 Auto DZ (AUTO dZ)

After the auto calibration, the positioner will create deadzone automatically. However, depending on the valve's period of use, hunting or oscillation may occur due to packing friction or other reasons and this function stabilizes the valve by detecting them automatically and increasing the deadzone at the time of its occurrence. This will stabilize the valve but deadzone is increased.

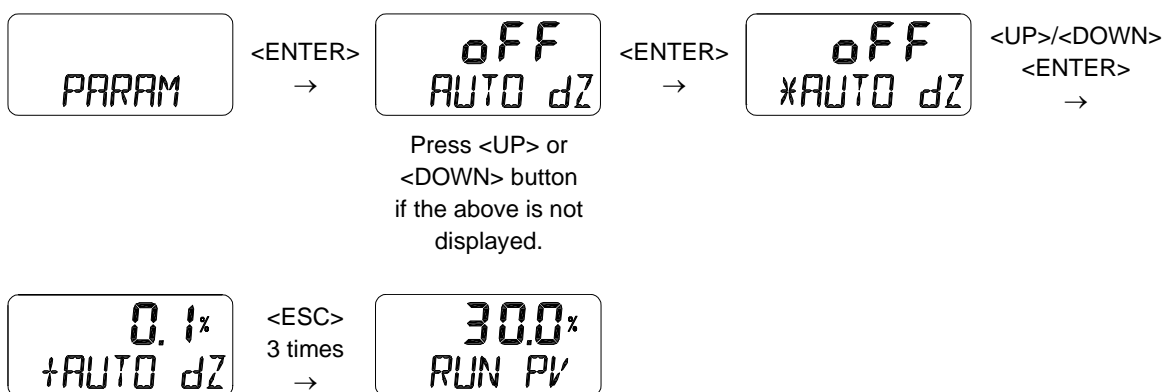

9.7 Hand Calibration Mode (HAND CAL)

Hand Calibration mode is used when zero-point and end-point require re-adjustment to use partial range of total strokes after Auto Calibration has been performed.

Below are the list of features which could be set from Hand CAL mode.

- 1) Zero-Point (PV_ZERO) and End-Point (PV_END) for Valves
- 2) Zero-Point (TR_ZERO) and End-Point (TR_END) for 4-20 mA Analog Output
- 3) Normal / Reverse 4-20 mA Analog Output (TR NORM / REVS)
- 4) Normal / Reverse HART Signal (HT NORM / REVS)

9.7.1 Zero-Point (PV_ZERO) and End-Point (PV_END) for Valves

PZ_ZERO adjusts the zero point of the valve, and PV_END adjusts the end point of the valve.

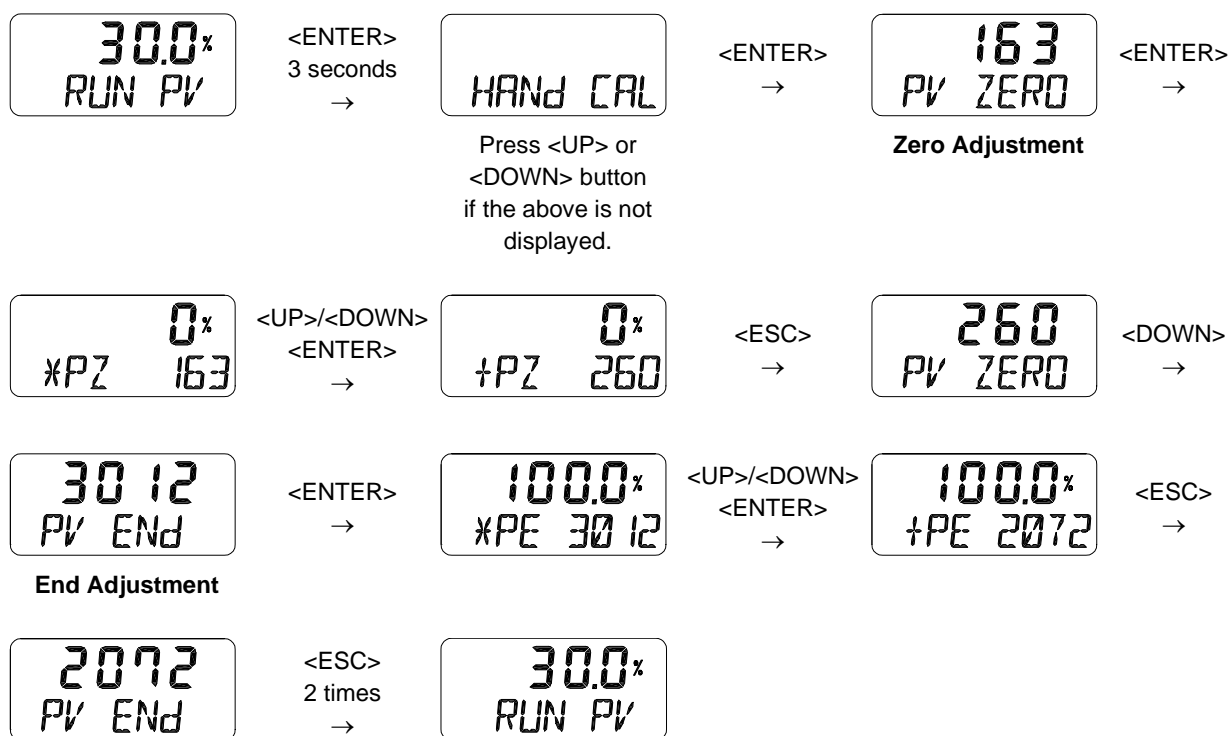

9.7.2 Zero-Point (TR_ZERO) and End-Point (TR_END) for 4-20 mA Analog Output

TR_ZERO adjusts the zero point of the Analog Output (4mA output), and TR_END adjusts the end point of the Analog Output (20 mA output). This is used when output signal becomes unstable and requires re-adjustment or when 4-20 mA Analog Output and actual stroke need to be used differently.

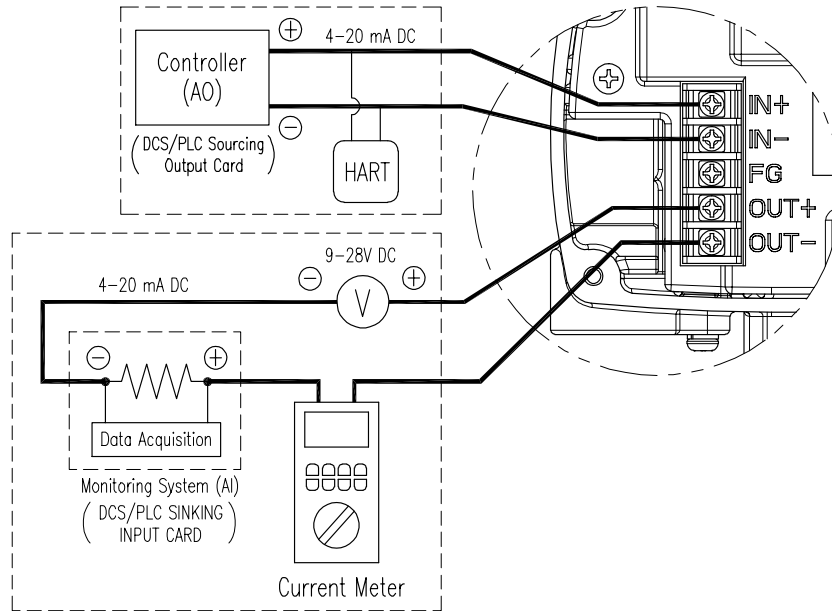
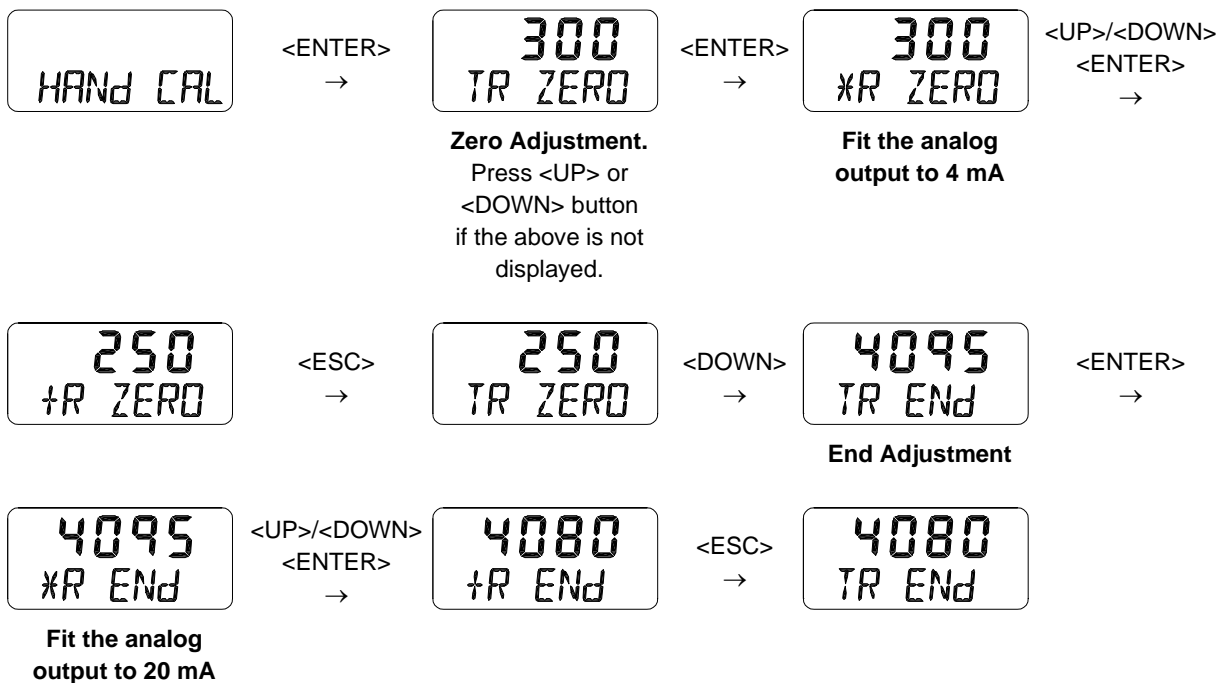
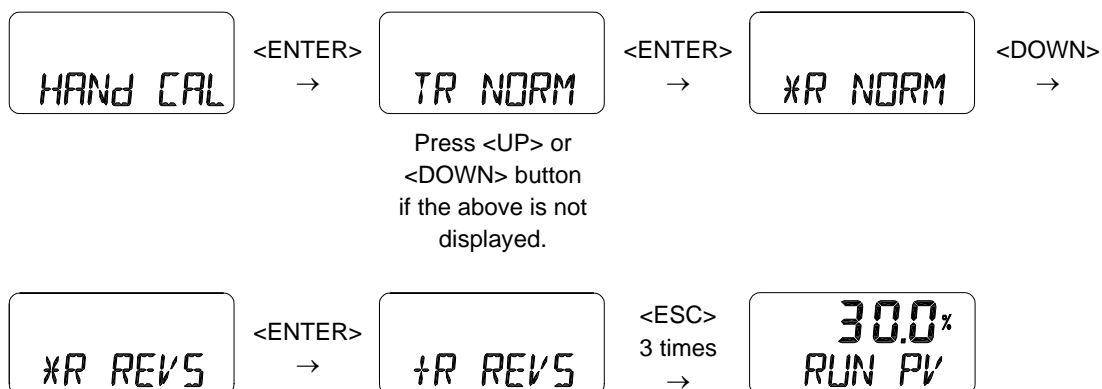

Fig. 9-3: Setting 4-20 mA Analog Output



9.7.3 Normal / Reverse 4-20 mA Analog Output (TR NORM / REVS)

The 4-20 mA Analog Output from the positioner can be changed to normal or reverse.



9.7.4 Normal / Reverse HART Signal (HT NORM / REVS)

Feedback signal of HART communication from the positioner can be changed to normal or reverse.

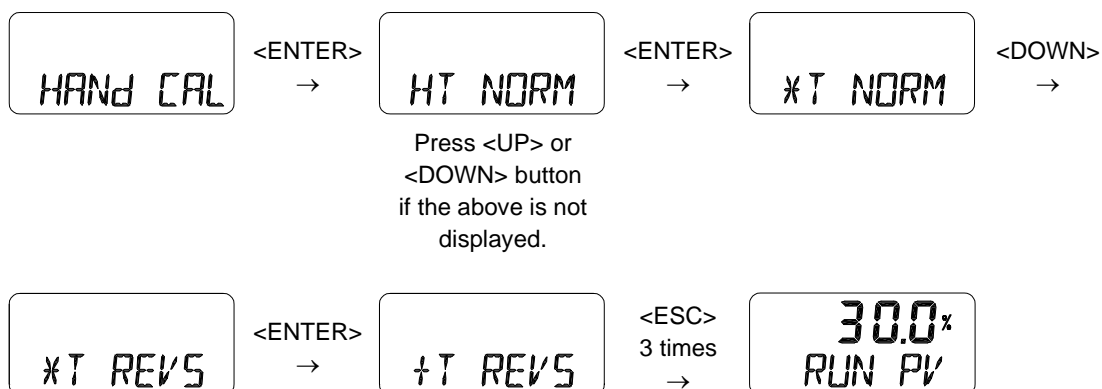

9.8 Valve Mode (VALVE)

Valve mode offers useful and various function settings for operating the control valve.

Below are the list of functions which could be set from Valve mode.

- 1) Acting Adjustment (ACT RA / dA)
- 2) Characteristic Adjustment (CHAR)
- 3) User Characteristics (USER SET)
- 4) Tight Shut Open (TSHUT OP)
- 5) Tight Shut Close (TSHUT CL)
- 6) Split Range Mode (SPLIT)

9.8.1 Acting Adjustment (ACT RA / dA)

RA & DA are automatically set by performing “AUTO 2” from Auto Calibration. However, this function is used when the user wants to change RA & DA.

The positioner can be set as Direct Action (DA) or Reverse Action (RA).

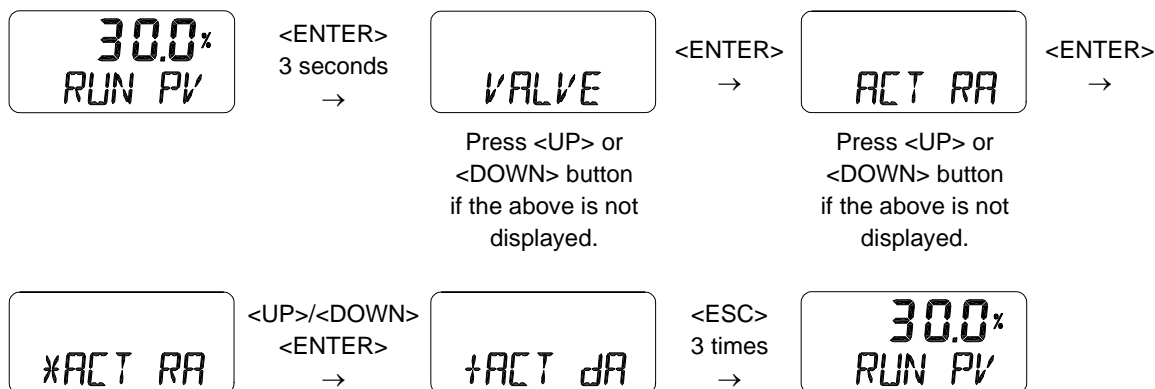

9.8.2 Valve flow Characteristic Adjustment (CHAR)

The valve flow characteristic can be set on the field's requirement. There are 4 types of characteristics – linear (LIN), user setting (USR), quick open (QO), and equal percentage (EQ).

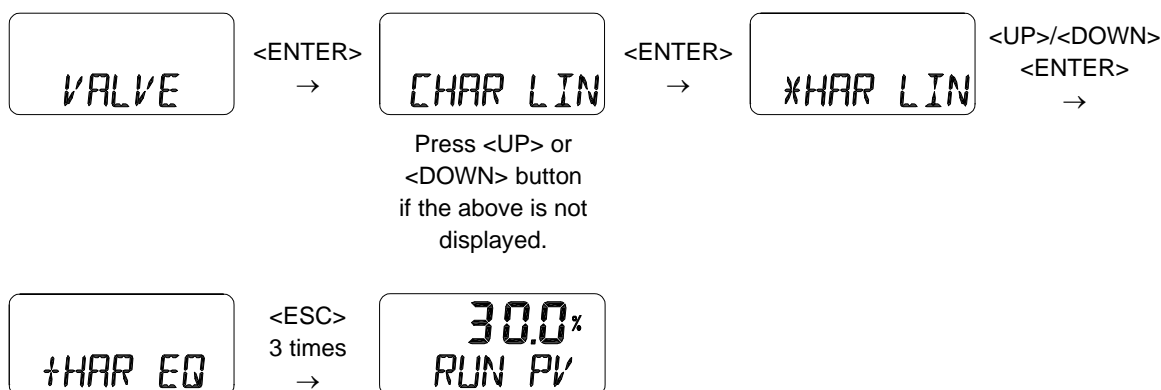
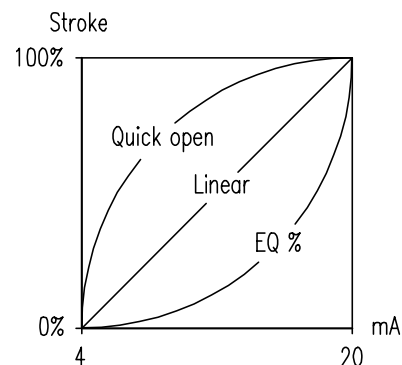

9.8.3 User defining flow Characteristics (USER SET)

User can make its own flow characteristic curve with this mode. USER SET can be set in two ways, 5 points and 18 points. User can choose whichever is more suitable for their application.

- 1) 5 points setting can be set with 4mA intervals. The initial positions are P0(4 mA = 0 %), P1(8 mA = 25 %), P2(12 mA = 50 %), P3(16 mA = 75 %) and P4(20 mA = 100 %) but user can change the % values to different values. User can change all 5 points or only change partially and exit the menu by pressing <ESC> button.

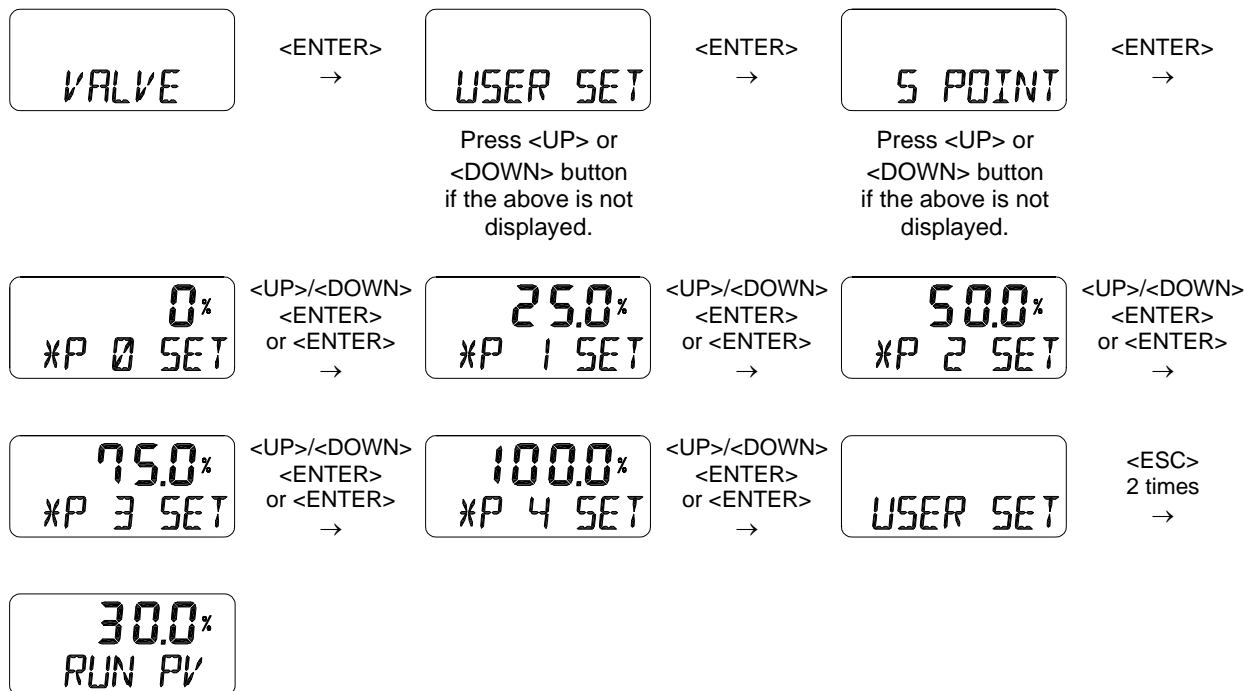

This function can be activated by selecting “CHAR USR” mode of above 9.8.2 Valve flow Characteristic Adjustment (CHAR).

- 2) 18 points setting can be set with 1mA intervals. The initial positions are P0(4 mA = 0 %), P1(5 mA = 6.25 %), P2(6 mA = 12.5 %), ... P16(20 mA = 100 %) and P17(21 mA = 106.25 %) but user can change the % values to different values. User can change all 18 points or only change partially and exit the menu by pressing <ESC> button.

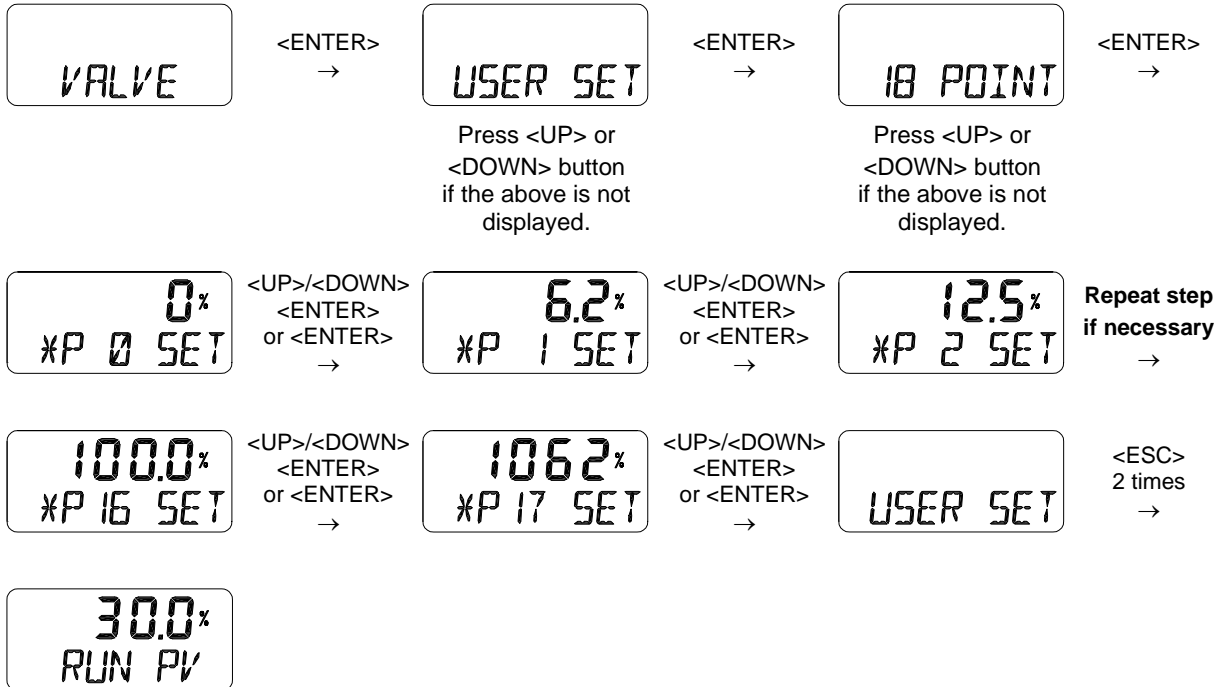

This function can be activated by selecting “CHAR USR” mode of above 9.8.2 Valve flow Characteristic Adjustment (CHAR).

9.8.4 Tight Shut Open (TSHUT OP)

Tight shut open shows the current value in percentage (%). Input current of 4 mA is 0 %, 20 mA is 100 %. If temporary Tight shut open value (≤ 100 %) is set and input current value is above the set % value, the valve’s position is immediately moved to 100 %. For example, if linear actuator is used and the valve’s closing direction is 100 % and input value of the current is above Tight shut open set value, the set pressure from the regulator will be transferred to the actuator which will enhance the power to close the valve and keep it from any leakage.

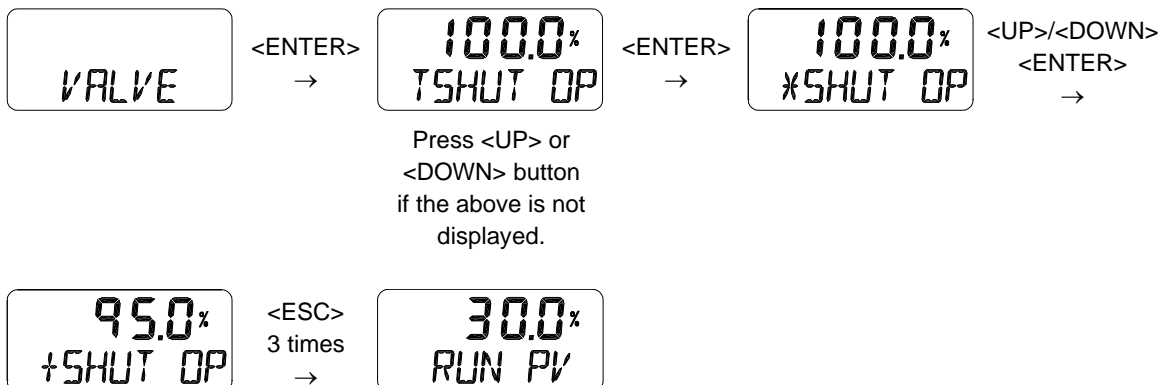

9.8.5 Tight Shut Close (TSHUT CL)

Tight shut close shows the current value in percentage (%). Input current of 4 mA is 0 %, 20 mA is 100 %. If temporary Tight shut close value (≤ 100 %) is set and input current value is below the set % value, the valve's position is immediately moved to 0 %. For example, if rotary actuator is used and the valve's closing direction is 0 % and input value of the current is above Tight shut open set value, it will release all the remaining pressure from Out1 of the actuator which will have the return spring power of the actuator or Out2 pressure to close the valve and keep it from any leakage.

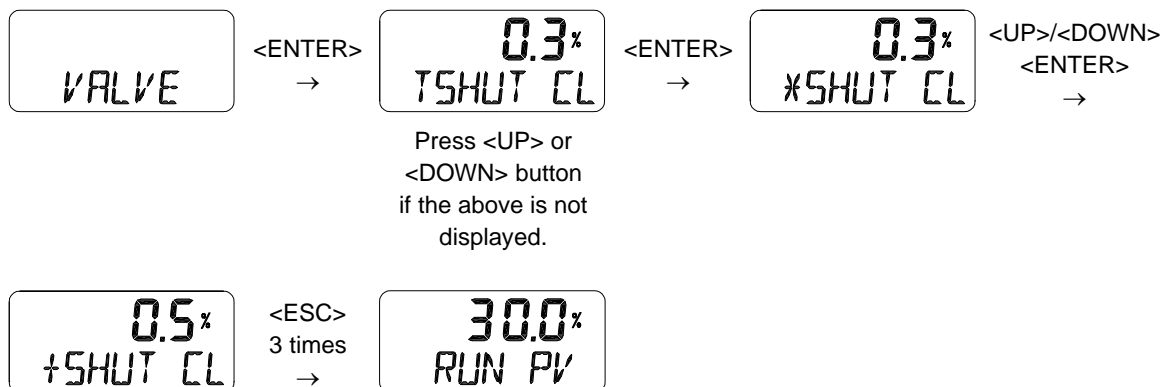

9.8.6 Split Range Mode (SPLIT)

The valve can be operated in full stroke by split range control of input signal as 4 to 12 mA or 12 to 20 mA.

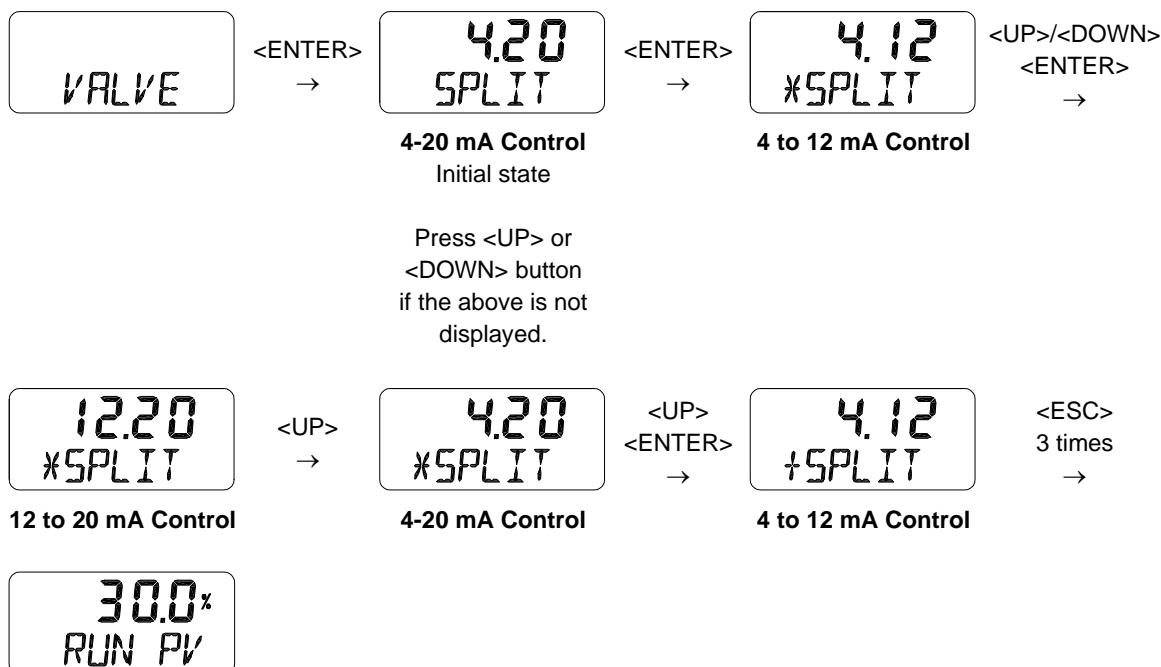

9.9 View Mode (VIEW)

Displays various information of the positioner.

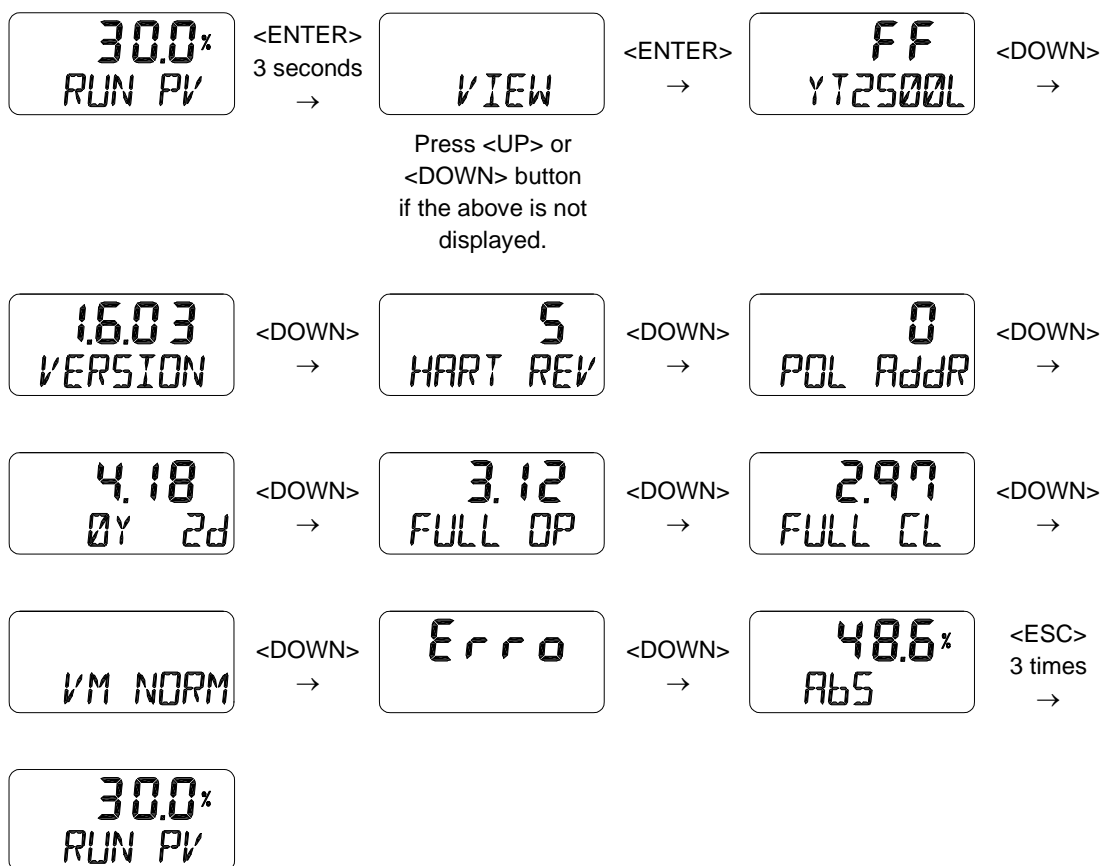

ITEM	Description
FF / FS YT-2500L	1'st row→FF: Fail Freeze / FS: Fail Safe. 2'nd row→Positioner model.
1.6.03 VERSION / 2020DC31	1'st row→version number of firmware. 2'nd row→VERSION: Main software version / 2020-12(DC)-31: loading date of software. (January JA, February FB, March MR, April AR, May MY, June JN, July JL, August AG, September SP, October OT, November NV, December DC) ※ You can toggle them, pushing <ENTER>
HART REV	HART protocol version
POL Addr	HART protocol channel address. ※ You can change it, pushing <ENTER>
4.18 0Y 0d	Total used time duration. If a unit was used less than 1 hour, the time will not accumulate. 1'st row→"4.18" means 4 hours and 18 minutes. 2'nd row→0Y: years, 0d: days
3.12 FULL OP	Time required (seconds) to fully open the current valve from the closed state. Saved after AUTO 2 or AUTO 3 Calibration.
2.97 FULL CL	Time required (seconds) to fully close the current valve from the opened state. Saved after AUTO 2 or AUTO 3 Calibration.
VM NOR / VM dIZ / VM REV	Display types of valve stroke on LCD. VM NOR : View Mode Normal. 4 mA → 0 %, 20 mA → 100 % display. VM dIZ : Raw data VM REV : View Mode Reverse. 4 mA → 100 %, 20 mA → 0 % display. ※ You can change it, pushing <ENTER>
Erro	Error code(C, D) or warning code(B, F, G, H). Refer to 10.3 or 10.4 sections
AbS	Absolute resistance value.

10 Error and Warning Code

Error or Warning code occur if there is a problem during Auto calibration or using the product.

- Error code : These are indicated if the positioner cannot be controlled, malfunctions or becomes imprecise.
- Warning code : These are indicated when the positioner can be controlled, but there is a possibility of malfunctioning or degree of precision has dropped.

10.1 Error code which is displayed during Auto calibration

Error Code	Code Description and Cause	Action
MT ERR L	<ul style="list-style-type: none"> ➤ Indicates that due to wrong positioning and installation of the positioner, there is a chance that the feedback lever and the positioner's stopper could collide when the lever is at 0 % during auto calibration. ➤ When this error is detected, auto calibration is aborted and this message is indicated immediately on LCD display. 	<ul style="list-style-type: none"> ➤ Set the feedback lever horizontally when at 50 %. ➤ Re-adjust the position of the positioner by referring to the following effective range of the feedback lever's angle (Linear : 30 deg., Rotary : 90 deg.)
MT ERR H	<ul style="list-style-type: none"> ➤ Indicates that due to wrong positioning and installation of the positioner, there is a chance that the feedback lever and the positioner's stopper could collide when the lever is at 100 % during auto calibration. ➤ When this error is detected, auto calibration is aborted and this message is indicated immediately on LCD display. 	
CHK AIR	<ul style="list-style-type: none"> ➤ Indicated when the valve is not moving despite the positioner has given "Full Open" signal during auto calibration. ➤ When this error is detected, auto calibration is aborted and this message is indicated immediately on LCD display. 	<ul style="list-style-type: none"> ➤ Check if pressure is being supplied normally to the positioner.

RNG ERR	<ul style="list-style-type: none"> ➤ Indicated when the feedback lever's angle used is excessively small during auto calibration. ➤ When this error is detected, auto calibration is aborted and this message is indicated immediately on LCD display. 	<ul style="list-style-type: none"> ➤ Re-install the positioner by moving it towards the actuator stem so that the angle use of the feedback lever becomes larger.
LEAK	<ul style="list-style-type: none"> ➤ Indicated when movement of feedback lever is detected without any pneumatic action of positioner during auto calibration. ➤ When this error is detected, auto calibration is aborted and this message is indicated immediately on LCD display. 	<ul style="list-style-type: none"> ➤ Check for leaks from output port of the positioner and piping.
PT ERR	<ul style="list-style-type: none"> ➤ Indicated when a leak is detected in "PT TIME" during AUTO 2 or 3 calibration. Auto calibration will stop and the error message will display on the LCD. 	<ul style="list-style-type: none"> ➤ Make sure there are no leak in the out ports of the positioner or pipe lines

10.2 Error code which is displayed while using the product

Error Code	Code Description and Cause	Action
OVER CUR	<ul style="list-style-type: none"> ➤ Indicated and blinked when 24 mA or more current is detected to the demand input terminal. ➤ Buttons will not work while this error message is displayed. 	<ul style="list-style-type: none"> ➤ Check the connection status to the demand input terminal. (miswiring, overcurrent input, etc.)

10.3 Error code which can be checked from View mode

Error Code	Code Description and Cause	Action
C	<ul style="list-style-type: none"> ➤ Indicated if the deviation between SV and PV is above 10 % and is continued for over one minute. ➤ Indicated when the valve does not operate, friction is extremely high or when the air regulator's set pressure is too low. ➤ Can be checked from "Error" category in View mode. (Refer to section 9.9) 	<ul style="list-style-type: none"> ➤ Re-perform auto-calibration. ➤ Check air regulator's set pressure and re-adjust to appropriate pressure.

D	<ul style="list-style-type: none"> ➤ Accumulated I value is I max or min's limit. ➤ Degree of precision is low. ➤ Indicated if valve's friction is extremely high or set pressure of air regulator has been changed. ➤ Can be checked from "Error" category in View mode. (Refer to section 9.9) 	<ul style="list-style-type: none"> ➤ Re-perform auto-calibration. ➤ Check air regulator's set pressure and re-adjust to appropriate pressure.
----------	--	---

10.4 Warning code which can be checked from View mode

Warning Code	Code Description and Cause	Action
B	<ul style="list-style-type: none"> ➤ PV Span – PV Zero range is below 500. ➤ Feedback lever's angle use is too low. ➤ Can be checked from "Error" category in View mode. (Refer to section 9.9) 	<ul style="list-style-type: none"> ➤ Re-position the positioner so that the angle use of the feedback lever is larger than current angle. Then, perform AUTO1 calibration.
F	<ul style="list-style-type: none"> ➤ Full open & Full close time is less than 1 second. ➤ Size of the actuator is too small. ➤ Can be checked from "Error" category in View mode. (Refer to section 9.9) 	<ul style="list-style-type: none"> ➤ Use orifice and lower the flow rate. ➤ Or replace the actuator with bigger size.
G	<ul style="list-style-type: none"> ➤ PV is set below 100. ➤ Feedback lever's angle use is set too high. ➤ Can be checked from "Error" category in View mode. (Refer to section 9.9) 	<ul style="list-style-type: none"> ➤ Re-position the positioner so that the angle use of the feedback lever is smaller than current angle. Then, perform AUTO1 calibration.
H	<ul style="list-style-type: none"> ➤ PV is set above 4000. ➤ Feedback lever's angle use is set too high. ➤ Can be checked from "Error" category in View mode. (Refer to section 9.9) 	

11 Main Software Map

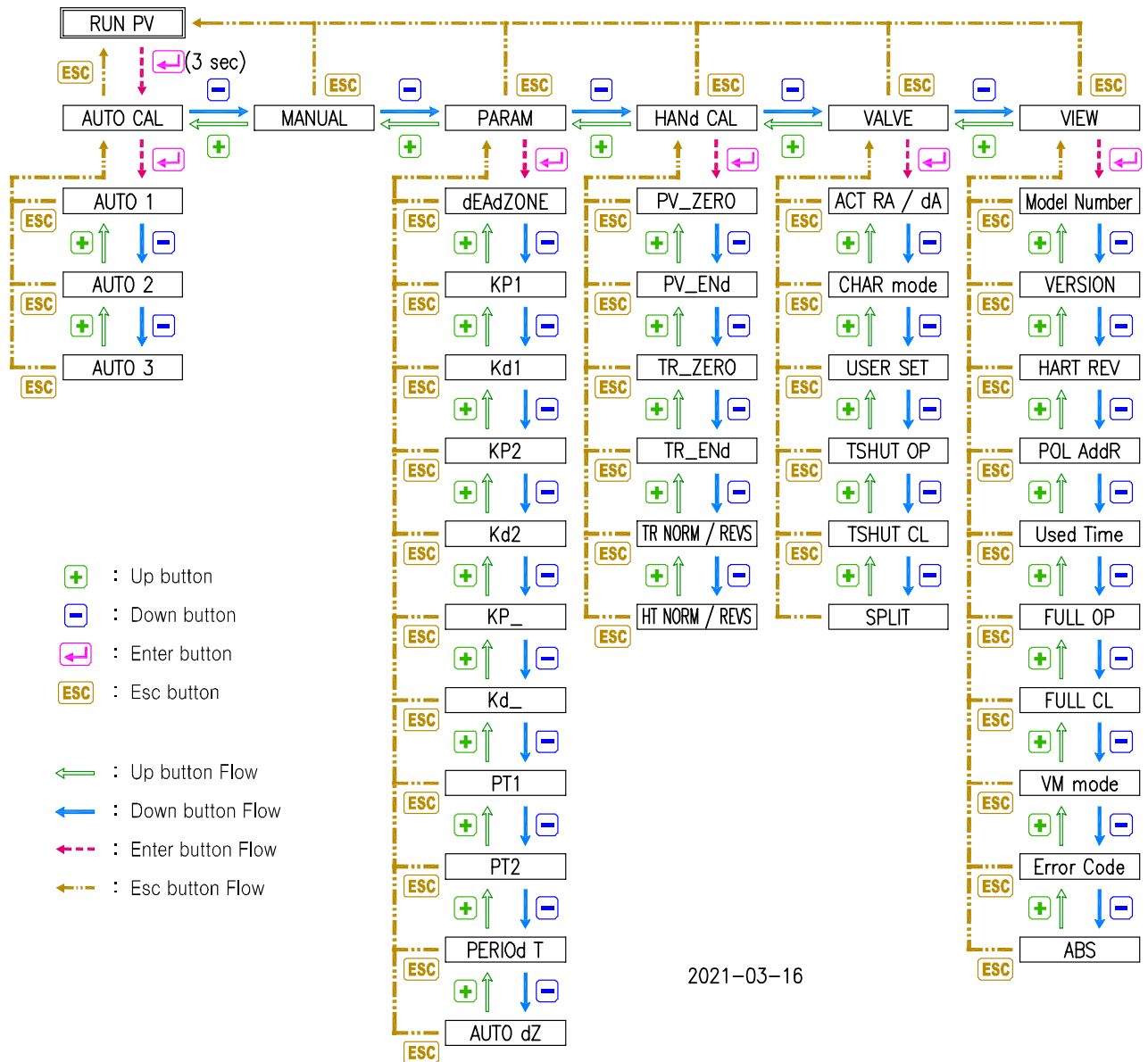

Manufacturer: Rotork YTC Limited

Address: 81, Hwanggeum-ro, 89 Beon-gil, Yangchon-eup, Gimpo-si, Gyeonggi-do, South Korea

Postal code: 10048

Tel: +82-31-986-8545

Fax: +82-70-4170-4927

Email: ytic.sales@rotork.com

Homepage : <http://www.ytc.co.kr>

Issued : 2025-02-19

Copyright © Rotork YTC Limited. All Rights Reserved.