

REV.NO.	REVISION DESCRIPTION	DRAWN / DATE	REVIEWED / DATE	APPROVED / DATE
	Previous versions omitted			
△	Operating → Ambient	KYJ/20201127	JCS/20201127	KTJ/20201127
△	Gauge threads integrated ...	KCH/20250116	JCS/20250116	KTJ/20250116

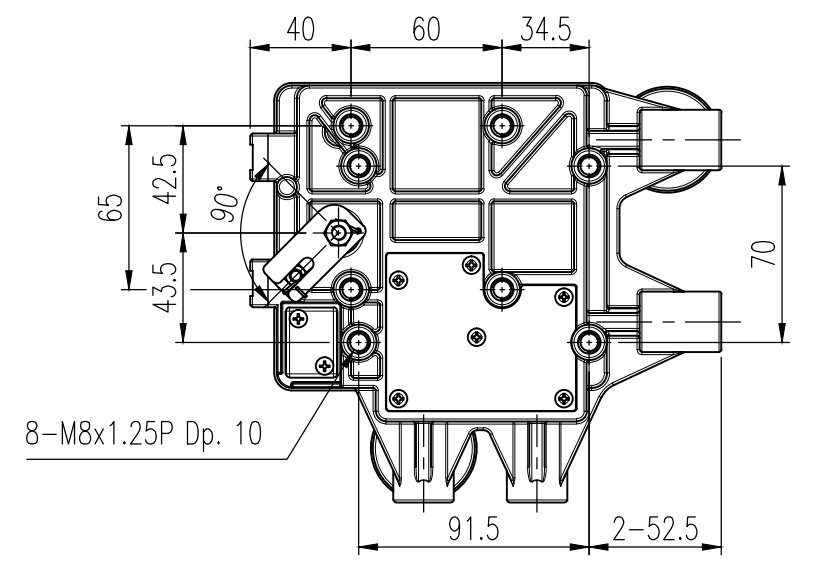
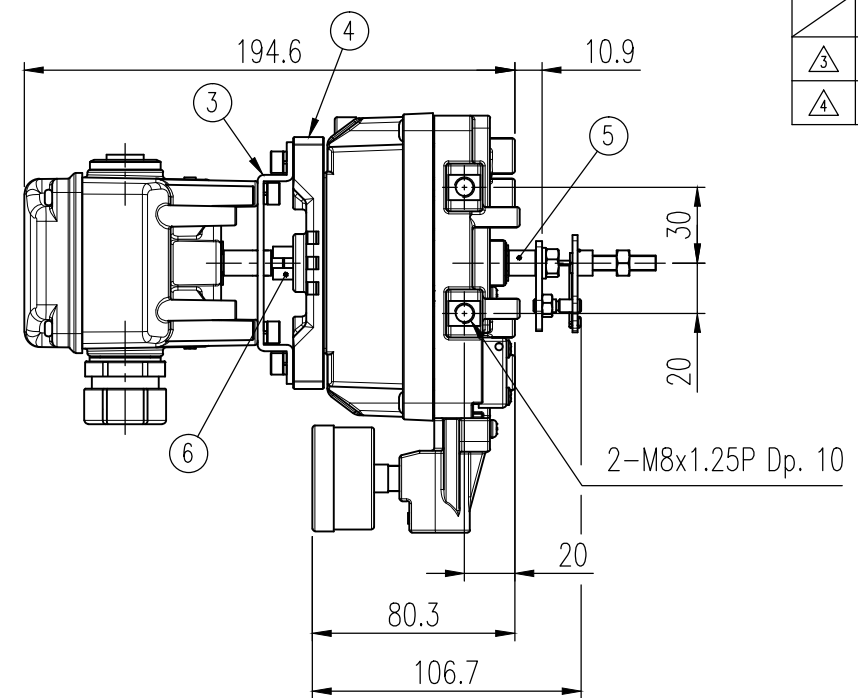
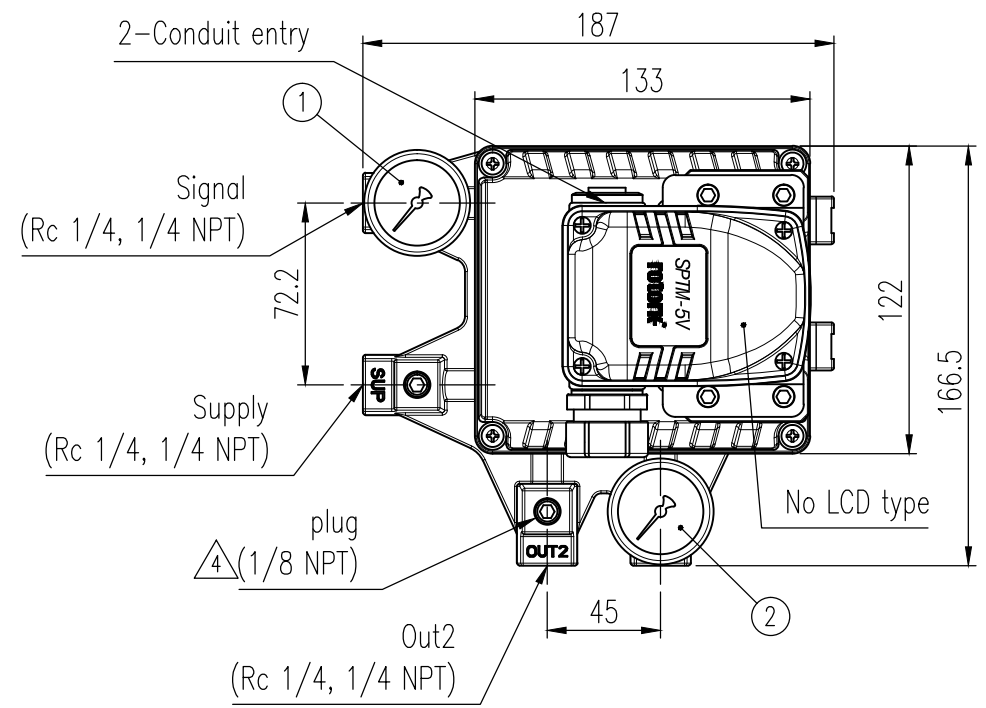

No.	Part name	Material	Q'ty	Remark
1	Pressure gauge	STS304	1	Signal, 0.2 MPa
2	Pressure gauge	STS304	1	Out1, 0.8 MPa
3	Bracket	STS304	1	
4	Bracket block	ALDC12	1	
5	Main shaft	STS303	1	
6	Adapter	STS303	1	
7	SPTM-5V	-	1	
8	Base cover	ALDC12	1	
9	Base body	ALDC12	1	

Specifications (SPTM-5V External)

Smart Position Transmitter	
Connection Type	2 Wire
Input Stroke	55 to 100°
LCD Option	<input type="checkbox"/> LCD <input type="checkbox"/> No LCD
Output Signal	4-20 mA DC
External Load Resistance	$R_{ext} \leq (V_s - 9) / 20 \text{ mA}$, 750 ohms @ $V_s = 24 \text{ V}$
Supply Voltage	9 to 28V DC
Conduit Entry	G 1/2
Explosion Protection	Non-Explosion proof
Ingress Protection	IP 67
Ambient temperature	-40 to 85°C (-40 to 185°F)
Linearity	± 1 % F.S.
Hysteresis	± 0.2 % F.S.
Sensitivity	± 0.2 % F.S.
Housing Material	Aluminum
Weight	0.6 kg (1.3 lb)

Specification (Positioner)

Motion type		Rotary	
Acting Type		<input type="checkbox"/> Single	<input type="checkbox"/> Double
Input Signal		0.02 to 0.1 MPa (0.2 to 1 bar)	
Supply Pressure		0.14 to 0.7 MPa (1.4 to 7 bar)	
Stroke		55 to 100°	
Air Connection		<input type="checkbox"/> Rc 1/4	<input type="checkbox"/> 1/4 NPT
Gauge Connection		1/8 NPT	
Ambient Temp.	Standard	<input type="checkbox"/> -20 to 70 °C (-4 to 158 °F)	
	Low	<input type="checkbox"/> -40 to 70 °C (-40 to 158 °F)	
Pressure Gauge	Signal	0.2 MPa	
	Output 1	0.8 MPa	
Linearity		± 2.0 % F.S.	
Hysteresis		± 1.0 % F.S.	
Sensitivity		± 0.5 % F.S.	
Repeatability		± 0.5 % F.S.	
Flow Capacity		> 80 LPM (Sup. = 0.14 MPa, 1.4 bar)	
Air Consumption		< 2.5 LPM (Sup. = 0.14 MPa, 1.4 bar)	
Ingress Protection		IP66 (excluding the pressure gauges)	
Weight		1.7 kg (3.1 lb)	
Feedback connection type		<input type="checkbox"/> M6x34L	<input type="checkbox"/> M6x63L
		<input type="checkbox"/> M8x34L	<input type="checkbox"/> M8x63L
		<input type="checkbox"/> NAMUR	
Housing Material		Aluminum	
Painting		Polyester Powder Coating	

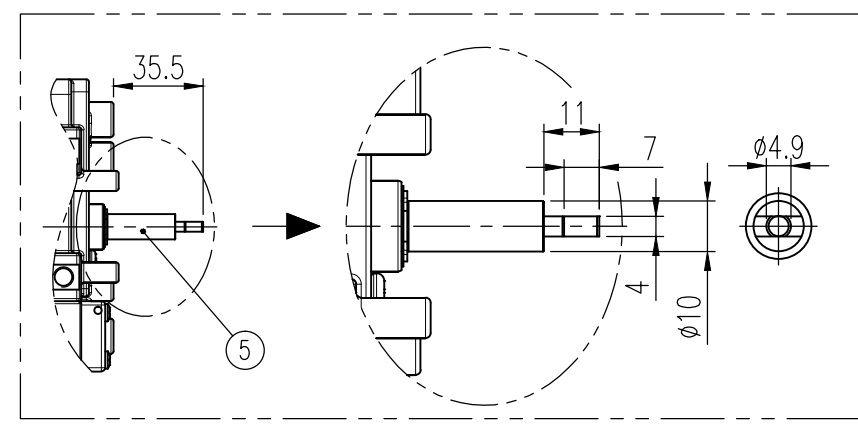
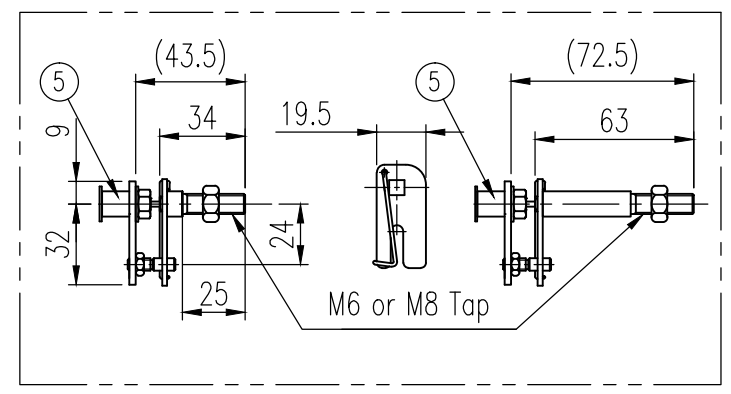
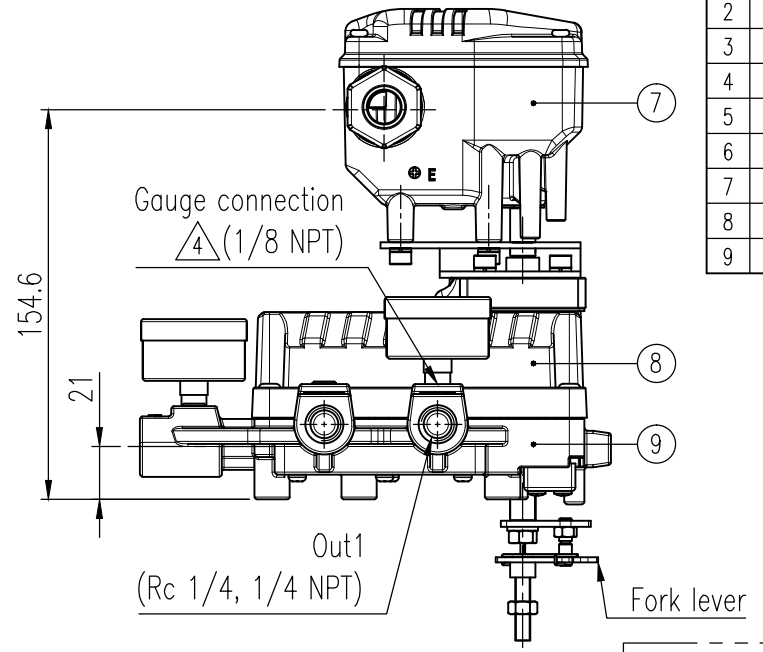

SURFACE TEXTURE	PRODUCT NAME	PROJECT NAME	
FINISH TREATMENT	P/P Positioner	-	
MATERIAL	MODEL	TITLE	
OTHERWISE NOTE	YT-1200R + SPTM-5V	Rotary, External SPTM, Non-explosion	
GENERAL TOLERANCE	PROJECTION	SCALE	DRAWING NO.
-	3rd	1 / 3	YT-1200R-03
-	QUANTITY	SHEET No.	REV.
-	1	1 / 1	4