

REV.NO.	REVISION DESCRIPTION	DRAWN / DATE	REVIEWED / DATE	APPROVED / DATE
	Previous versions omitted			
△	Operating → Ambient	KYJ/20201127	JCS/20201127	KTJ/20201127
△	Gauge threads integrated ...	KCH/20250102	JCS/20250102	KTJ/20250102

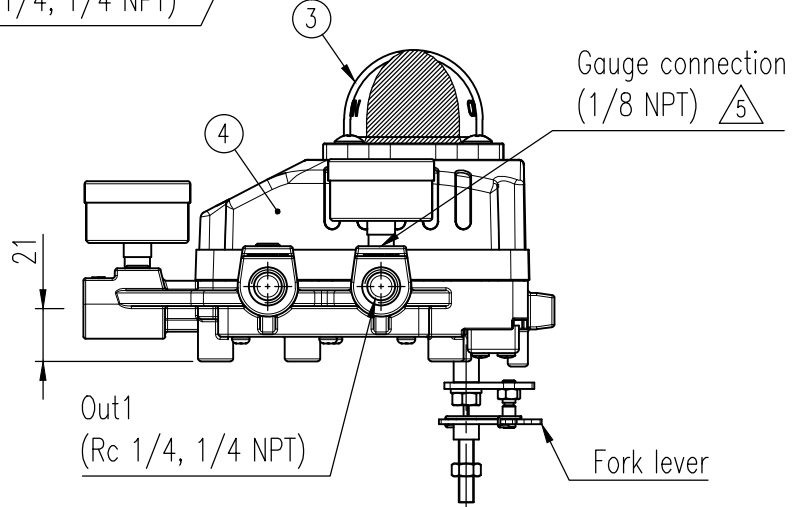

Specification

Motion type	Rotary		Linearity	± 2.0 % F.S.
Acting Type	<input type="checkbox"/> Single	<input type="checkbox"/> Double	Hysteresis	± 1.0 % F.S.
Input Signal	0.02 to 0.1 MPa (0.2 to 1 bar)		Sensitivity	± 0.5 % F.S.
Supply Pressure	0.14 to 0.7 MPa (1.4 to 7 bar)		Repeatability	± 0.5 % F.S.
Stroke	55 to 100°		Flow Capacity	> 80 LPM (Sup. = 0.14 MPa, 1.4 bar)
Air Connection,	<input type="checkbox"/> Rc 1/4	<input type="checkbox"/> 1/4 NPT	Air Consumption	< 2.5 LPM (Sup. = 0.14 MPa, 1.4 bar)
Gauge Connection	△ 1/8 NPT		Ingress Protection	IP66 (excluding the pressure gauges)
Ambient Temp.	Standard	<input type="checkbox"/> -20 to 70 °C (-4 to 158 °F)	Weight	1.7 kg (3.1 lb)
	High	<input type="checkbox"/> -20 to 120 °C (-4 to 248 °F)	Feedback connection type	<input type="checkbox"/> M6x34L <input type="checkbox"/> M6x63L <input type="checkbox"/> NAMUR
	Low	<input type="checkbox"/> -40 to 70 °C (-40 to 158 °F)	Housing Material	Aluminum
Pressure Gauge	Signal	0.2 MPa	Painting	Polyester Powder Coating
	Output 1	0.8 MPa		

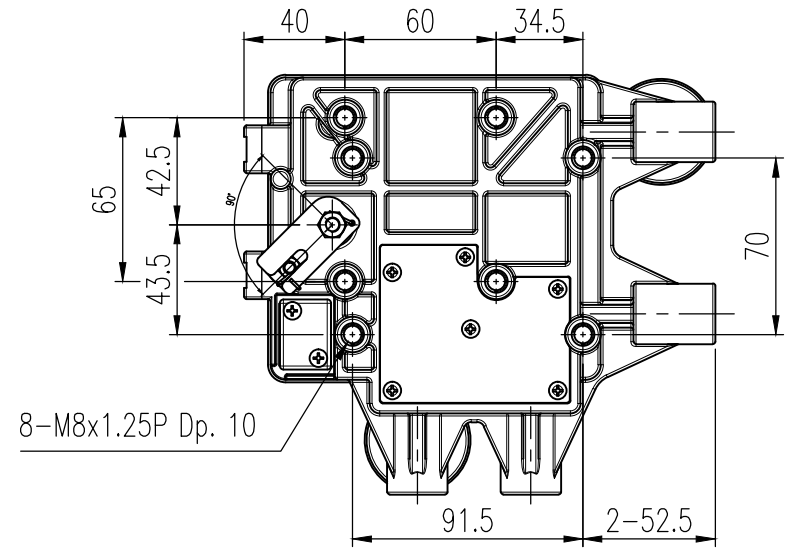
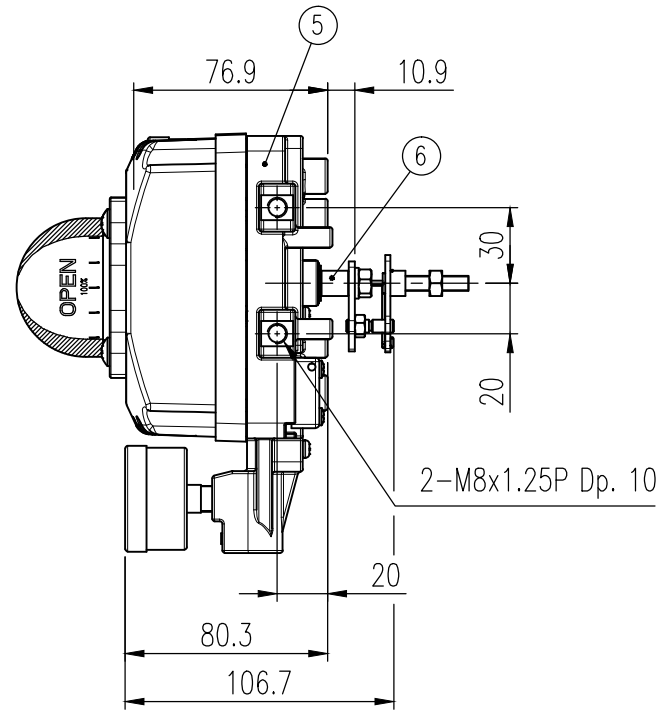
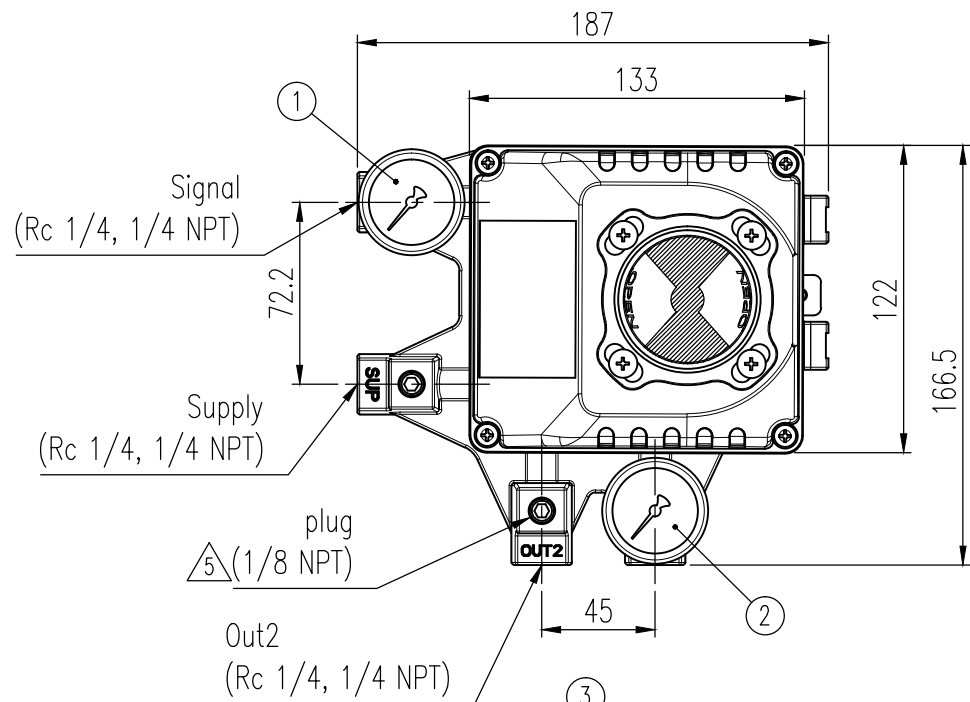
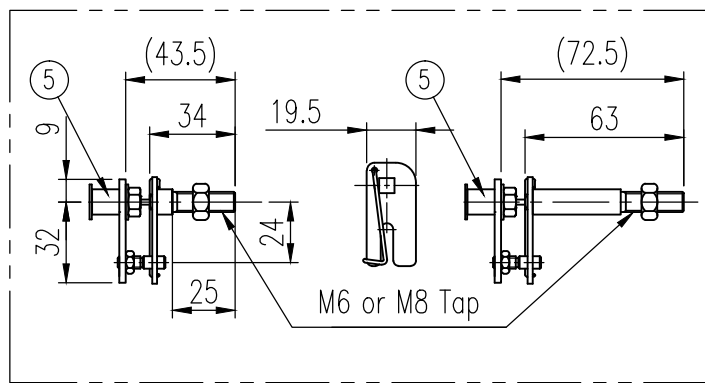

Fork lever type

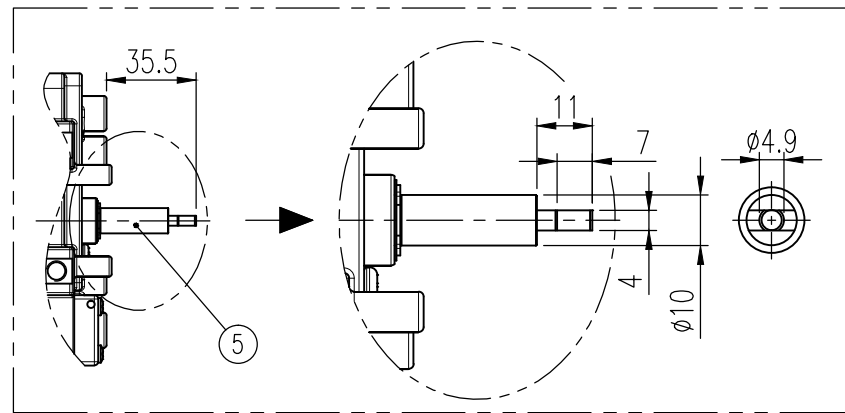

NAMUR shaft type

No.	Part name	Material	Q'ty	Remark
1	Pressure gauge	STS304	1	Signal, 0.2 MPa
2	Pressure gauge	STS304	1	Out1, 0.8 MPa
3	Indicator dome	Polycarbonate	1	
4	Base cover	ALDC12	1	
5	Base body	ALDC12	1	
6	Main shaft	STS303	1	

SURFACE TEXTURE	PRODUCT NAME	P/P Positioner	
FINISH TREATMENT	MODEL	YT-1200R	
MATERIAL	PROJECTION	SCALE	1 / 3
OTHERWISE NOTE	GENERAL TOLERANCE	QUANTITY	1
		SHEET No.	1 / 1

PROJECT NAME		-	
rotork		Rotork YTC Limited	
GIMPO-SI, KOREA		TITLE	
Rotary, Indicator dome type		DRAWING NO.	
YT-1200R-02		REV.	
5			