



Contents

1	Introduction	4
1.1	General Information for the users	4
1.2	Manufacturer Warranty	4
1.3	Explosion Proof Warning (Only for external explosion proof product, not for positioner)	5
2	Product Description	6
2.1	General	6
2.2	Main Features and Functions	6
2.3	Label Description	7
2.4	Product Code	8
2.5	Product Specification	9
2.5.1	Positioner Specification	9
2.5.2	Specification of External Analog Output option	10
2.5.3	Specification of External L/S option	11
2.6	Certifications of External products	12
2.6.1	SPTM-5V	12
2.6.2	SPTM-6V	12
2.6.3	YT-850	12
2.6.4	YT-870	12
2.7	Parts and Assembly	14
2.7.1	YT-1200L	14
2.7.2	YT-1000R	14
2.7.3	YT-1200R + SPTM-6V (External)	15
2.7.4	YT-1000R + YT-870 (External)	15
2.8	Product Dimension	16
2.8.1	YT-1200L	16
2.8.2	YT-1200R (Fork Lever type)	16
2.8.3	YT-1200R (Namur type)	17
2.8.4	YT-1200R (Dome indicator)	17
2.8.5	YT-1200R (External SPTM-6V)	18
2.8.6	YT-1000R (External Limit Switch, YT-870)	19
3	principle of positioner movement	20
3.1	Linear Positioner	20
3.2	Rotary Positioner	21
4	Installation	22
4.1	Safety	22
4.2	Tools for installation	22
4.3	Linear positioner Installation	23
4.3.1	Preparing Bracket for the positioner	23
4.3.2	Installation Steps	24

4.4	Rotary positioner Installation	28
4.4.1	Components.....	28
4.4.2	Rotary Bracket Information	29
4.4.3	Rotary positioner Installation Steps	30
5	Connection - Air	32
5.1	Safety	32
5.2	Supply Pressure Condition	32
5.3	Piping Condition.....	32
5.4	Connection – Piping with actuator	33
5.4.1	Single acting actuator	33
5.4.2	Double acting actuator.....	35
6	Adjustments	37
6.1	Ra or Da Setting	37
6.1.1	Linear Positioner	37
6.1.2	Rotary positioner.....	38
6.2	Adjustment - Zero Point and Span (Calibration).....	39
6.2.1	Precautions before zero point adjustment and span adjustment	39
6.2.2	Adjustment steps	39
6.3	Adjustment – A/M switch (Auto/Manual).....	41
6.4	Orifice Installment	42
7	Maintenance	43
7.1	Pilot valve.....	43
7.2	Seals	43
8	Troubleshooting.....	44

1 Introduction

1.1 General Information for the users

Thank you for purchasing Rotork YTC Limited products. Each product has been fully inspected after its production to offer you the highest quality and reliable performance. Please read the product manual carefully prior to installing and commissioning the product.

- Installation, commissioning, and maintenance of the product may only be performed by trained specialist personnel who have been authorized by the plant operator accordingly.
- The manual should be provided to the end-user.
- The manual can be altered or revised without any prior notice. Any changes in product's specification, design, and/or any components may not be printed immediately but until the following revision of the manual.
- When the manual refers to "**Valve Zero / Zero**" means the final valve position upon pneumatic pressure has been fully exhausted from positioner's OUT1 port. For example, the valve zero position may differ between linear direct and reverse actions. (DA/RA)
- The manual should not be duplicated or reproduced for any purpose without prior approval from Rotork YTC Limited, Gimpo-si, South Korea.
- In case of any other problems that are not stated in this manual, please make immediate contact to Rotork YTC Limited.
- Positioner is an accessory of the control valve, so please make sure to read the applicable instruction manual of the control valve prior to installation and operation.

1.2 Manufacturer Warranty

- For the safety, it is important to follow the instructions in the manual. Manufacturer will not be responsible for any damages caused by user's negligence.
- Any modifications or repairs to the product may only be performed if expressed in this manual. Injuries and physical damages caused by customer's modifying or repairing the product without a prior consultation with Rotork YTC Limited will not be compensated. If any alterations or modifications are necessary, please contact Rotork YTC Limited directly.
- The warranty period for the product is (12) months from the date of shipment unless otherwise stated. Customers can extend the warranty period by an additional (12) months by registering the product's serial number or lot number, customer information, and installation address on the warranty extension application site Product Registration (<https://www.rotork.com/en/service/product-registration>).
- Manufacturer warranty will not cover products that have been subjected to abuse, accidents, alterations, modifications, tampering, negligence, misuse, faulty installation, lack of reasonable care, repair or service in any way that is not contemplated in the documentation for the product, or if the model or serial number has been altered, tampered with, defaced or removed; damages that occurs in shipment, due to act of God, failure due to power surge, or cosmetic damage.

Improper or incorrectly performed maintenance will void this limited warranty.

- For detailed warranty information, please contact the corresponding local Rotork YTC Limited office or main office in South Korea.

1.3 Explosion Proof Warning (Only for external explosion proof product, not for positioner)

Please ensure the unit is being used and installed in conformity with local, regional, and national explosion proof environment.

- Refer to “2.6 Certifications”
- Explosion proof type of cables and gaskets should be used, when explosion gases are present at the installation site.
- If wires are connected to external explosion-proof products installed on top of the positioner, the power must be completely disconnected before opening the cover. When opening the cover, make sure to check that there is no current or voltage on any part of the product. If any doubts, please allow sufficient time for the remaining current and voltage to disappear completely.
- External explosion proof product has 2 ports for power connection. Explosion proof type wires and packing should be used. Blind plug is required when any port is not being used.
- Ring terminal with surface area of more than 0.195 mm² with M4 spring washer should be used to connect the power.
- For external ground terminal, ring terminal with surface area of more than 5.5 mm² should be used.
- There is risk of explosion due to static electricity charge. Static electricity charge may develop when cleaning the product with a dry cloth. It is imperative to avoid static electricity charge in the hazardous environment. If cleaning the surface of the product is needed, must use wet clothes.
- To meet explosion-proof marking information and ingress protection of IP66, use certified Ex-cable glands and Ex-plugs.
- If you need additional information about the values of the flameproof joints, contact Rotork YTC Limited directly.



2 Product Description

2.1 General

YT-1200 series Pneumatic Positioner accurately controls valve stroke in response to an input signal pressure of 0.02 to 0.1 MPa(0.2 to 1 bar) from the controller.

2.2 Main Features and Functions

- It is compatible with most of controllers.
- Response time is very fast and accurate.
- Split range 0.02 to 0.06 MPa or 0.06 to 0.1 mA can be set by simple operating.
- Low air consumption.
- Simple Direct / Reverse Action change.
- Simple Zero & Span adjustment.
- External options, such as 4-20 mA Analog Output and/or limit switch (L/S) are available.
- Orifices can be installed even in the field to minimize the hunting occurrence and optimize operating conditions.
- A/M switch can be used to direct supply air to the actuator or to manually operate the positioner or valve without any signal.
- It has IP66 ingress protection grade. (excluding the pressure gauges)
- Polyester powder coating resists the corrosion process.
- Maintenance of the positioner is easy because of modularized inner structure.

2.3 Label Description

- MODEL : Indicates the model number and additional options.
- SERIAL NUMBER : Indicates unique serial number.
- MONTH.YEAR : Indicates manufactured month and year.
- AMBIENT TEMP. : Indicates the allowable ambient temperature.
- INPUT SIGNAL: Indicates input signal pressure range.
- SUPPLY PRESSURE : Indicates the supply pressure range.
- AIR CONNECTION : Indicates connection thread type.

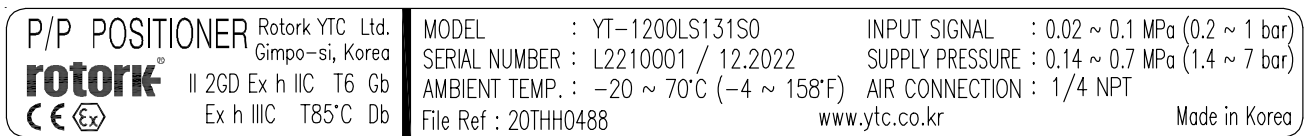

Fig. L-1: Sticker label

※ For information on the nameplate of external product, please check the corresponding product manual.

2.4 Product Code

YT-1200 1 2 3 4 5 6 7

1 Motion type	L : Linear R : Rotary				
2 Acting type	S : Single D : Double				
3 Lever Type	<table style="border-collapse: collapse; width: 100%;"> <tr> <td style="border: none; padding-right: 10px;">Linear</td> <td style="border: none;">1 : 10 to 40 mm 2 : 30 to 70 mm 3 : 60 to 100 mm 4 : 100 to 150 mm</td> </tr> <tr> <td style="border: none; padding-right: 10px;">Rotary</td> <td style="border: none;">1 : M6 x 34L 2 : M6 x 63L 3 : M8 x 34L 4 : M8 x 63L 5 : NAMUR</td> </tr> </table>	Linear	1 : 10 to 40 mm 2 : 30 to 70 mm 3 : 60 to 100 mm 4 : 100 to 150 mm	Rotary	1 : M6 x 34L 2 : M6 x 63L 3 : M8 x 34L 4 : M8 x 63L 5 : NAMUR
Linear	1 : 10 to 40 mm 2 : 30 to 70 mm 3 : 60 to 100 mm 4 : 100 to 150 mm				
Rotary	1 : M6 x 34L 2 : M6 x 63L 3 : M8 x 34L 4 : M8 x 63L 5 : NAMUR				
4 Orifice Type	1 : Ø1 2 : Ø2 3 : None				
5 Air Connection Type	1 : Rc 1/4 2 : 1/4 NPT				
6 Ambient Temp.	S : -20 to 70 °C (-4 to 158 °F) H : -20 to 120 °C (-4 to 248 °F) L : -40 to 70 °C (-40 to 158 °F)				
7 Option (Only Rotary type)	0 : None 1 : Dome cover 2 : 4-20 mA Analog Output – SPTM-5V(Non-explosion proof) ¹⁾ 3 : 4-20 mA Analog Output – SPTM-6V(Flameproof enclosure) ²⁾ 4 : Limit switch(2ea) – YT-850(Non-explosion proof) ³⁾ 5 : Limit switch(2ea) – YT-870(Flameproof enclosure) ⁴⁾ 6 : 4-20 mA Analog Output + Limit switch(2ea) – YT-870 (Flameproof enclosure) ⁵⁾				

¹⁾ ²⁾ these options are only available for “S”, “L” in 6 operating temperature.

³⁾ ⁴⁾ ⁵⁾ these options are only available for “S” in 6 operating temperature.

2.5 Product Specification

2.5.1 Positioner Specification

Model		YT-1200			
Housing Material		Aluminum			
Motion Type		Linear		Rotary	
Acting Type		Single	Double	Single	Double
Input Signal pressure		0.02 to 0.1 MPa (0.2 to 1 bar)			
Supply Pressure		0.14 to 0.7 MPa (1.4 to 7 bar)			
Stroke		10 to 150 mm		55 to 100°	
Air Connection		Rc 1/4 or 1/4 NPT			
Gauge Connection		1/8 NPT			
Ingress Protection		IP66 (excluding the pressure gauges)			
Ambient Temperature	Standard	-20 to 70 °C (-4 to 158 °F)			
	High	-20 to 120 °C (-4 to 248 °F)			
	Low	-40 to 70 °C (-40 to 158 °F)			
Linearity		± 1 % F.S.		± 2 % F.S.	
Hysteresis		± 1 % F.S.			
Sensitivity		± 0.2 % F.S.		± 0.5 % F.S.	
Repeatability		± 0.5 % F.S.			
Flow Capacity		80 LPM (Sup. = 0.14 MPa)			
Air Consumption		2.5 LPM (Sup. = 0.14 MPa @ idle)			
Weight		1.7 kg (3.1 lb)			
Painting		Polyester Powder Coating			



Tested under ambient temperature of 20 °C, absolute pressure of 760 mmHg, and humidity of 65 %.

Please contact Rotork YTC Limited for detailed testing specification.

2.5.2 Specification of External Analog Output option

External SPTM Model		SPTM-5V	SPTM-6V
Explosion Protection		Non-explosion proof	Flameproof enclosure. Refer to 2.6 Certifications.
Housing Material		Aluminum	
Input Stroke		55 to 100°	
Output Signal		4-20 mA DC	
External Load Resistance		$R_{ext} \leq (V_s - 9) / 20 \text{ mA}$, 750 ohms @ $V_s = 24 \text{ V}$	
Supply Voltage		V_s : 9 to 28 V DC	
Linearity		± 1 % F.S.	
Hysteresis		± 0.2 % F.S.	
Sensitivity		± 0.2 % F.S.	
Conduit Entry		G 1/2	
Ingress Protection		IP67	
Ambient Temperature	Explosion proof	-	Refer to 2.6.2
	Operating	-40 to 85 °C (-40 to 185 °F)	
Weight		0.6 kg (1.3 lb)	1.3 kg (2.9 lb)
Painting		Polyester Powder Coating	



Tested under ambient temperature of 20 °C, absolute pressure of 760 mmHg, and humidity of 65 %.

Please contact Rotork YTC Limited for detailed testing specification.

2.5.3 Specification of External L/S option

External L/S Model		YT-850
Housing Material		Aluminum
Switch Type		Mechanical Type (2 x SPDT)
Model No. & Manufacturer		SS-5GL (OMRON)
Switch Rating	AC	250 V 3 A, 125 V 5 A
	DC	250 V 0.2 A, 125 V 0.4 A, 30 V 4 A, 14 V 5 A, 8 V 5 A
Terminal		8 Points
Conduit Entry		1/2 NPT or G 1/2 or M20x1.5P
Ingress Protection		IP67
Explosion Protection		Non-explosion proof
Ambient Temperature		-25 to 70 °C (-13 to 158 °F)
Weight		880 g (1.94 lb)
Painting		Polyester Powder Coating



Tested under ambient temperature of 20 °C, absolute pressure of 760 mmHg, and humidity of 65 %.
Please contact Rotork YTC Limited for detailed testing specification.

External L/S Model		YT-870	
Housing Material		Aluminum	
Switch Type		Mechanical Type (2 x SPDT)	Inductive Proximity Sensor
Model No. & Manufacturer		SS-5GL (OMRON)	PS17-5DNU (Autonics)
Switch Rating	AC	250 V 3 A, 125 V 5 A	-
	DC	250 V 0.2 A, 125 V 0.4 A, 30 V 4 A, 14 V 5 A, 8 V 5 A	12 to 24 V
Terminal		8 Points	
Conduit Entry		G 3/4 (for CCC, 1/2 NPT)	
Ingress Protection		IP67	
Explosion Protection		Flameproof enclosure. Refer to "2.6.5 Certifications"	
Ambient Temperature		-20 to 60 °C (-4 to 140 °F)	
Weight		1.5 Kg (3.3 lb)	
Painting		Polyester Powder Coating	



Tested under ambient temperature of 20 °C, absolute pressure of 760 mmHg, and humidity of 65 %.
Please contact Rotork YTC Limited for detailed testing specification.

2.6 Certifications of External products

※ All certifications below are posted on Rotork YTC Limited homepage(www.ytc.co.kr).

2.6.1 SPTM-5V

➤ **Electromagnetic Compatibility (EMC)**

- EMC directive 2014/30/EC from April 2016
- EC Directive for CE conformity marking

2.6.2 SPTM-6V

➤ **KC (Korea)**

Rating : Ex d IIC T6 IP67
Certification No. : 12-KB2BO-0313
Ambient temperature : -40 to 60°C (-40 to 140°F)

➤ **Electromagnetic Compatibility (EMC)**

- EMC directive 2014/30/EC from April 2016
- EC Directive for CE conformity marking

2.6.3 YT-850

➤ **Electromagnetic Compatibility (EMC)**

- EMC directive 2014/30/EC from April 2016
- EC Directive for CE conformity marking

2.6.4 YT-870

➤ **KC (Korea)**

Rating : Ex d IIC T6
Certification No. : 12-KB2BO-0093
Ambient temperature : -20 to 60°C (-4 to 140°F)

➤ **ATEX**

Rating : II 2G Ex db IIC T6 Gb, II 2D Ex tb IIC T85°C Db
Certification No. : EPS 16 ATEX 1 140 X
Ambient temperature : -20 to 60°C (-4 to 140°F)

➤ **IECEX**

Rating : Ex db IIC T6 Gb, Ex tb IIIC T85°C Db
Certification No. : IECEX EPS 14.0053X
Ambient temperature : -20 to 60°C (-4 to 140°F)

➤ **CSA**

Rating : Ex db IIC T6

Class I, Zone 1, AEx db IIC T6

Class II, Division 1, Groups E, F and G; Ex tb IIIC T85°C

Zone 21, AEx tb IIIC T85°C

Type 4, 4X ; IP67

Certification No. : 2541711

Ambient temperature : -20 to 60°C (-4 to 140°F)

➤ **CCC (China)**

Rating : Ex db IIC T6 Gb, Ex tb IIIC T85°C Db

Certification No. : 2020322307000620

Ambient temperature : -20 to 60°C (-4 to 140°F)

➤ **Electromagnetic Compatibility (EMC)**

- EMC directive 2014/30/EC from April 2016

- EC Directive for CE conformity marking

2.7 Parts and Assembly

2.7.1 YT-1200L

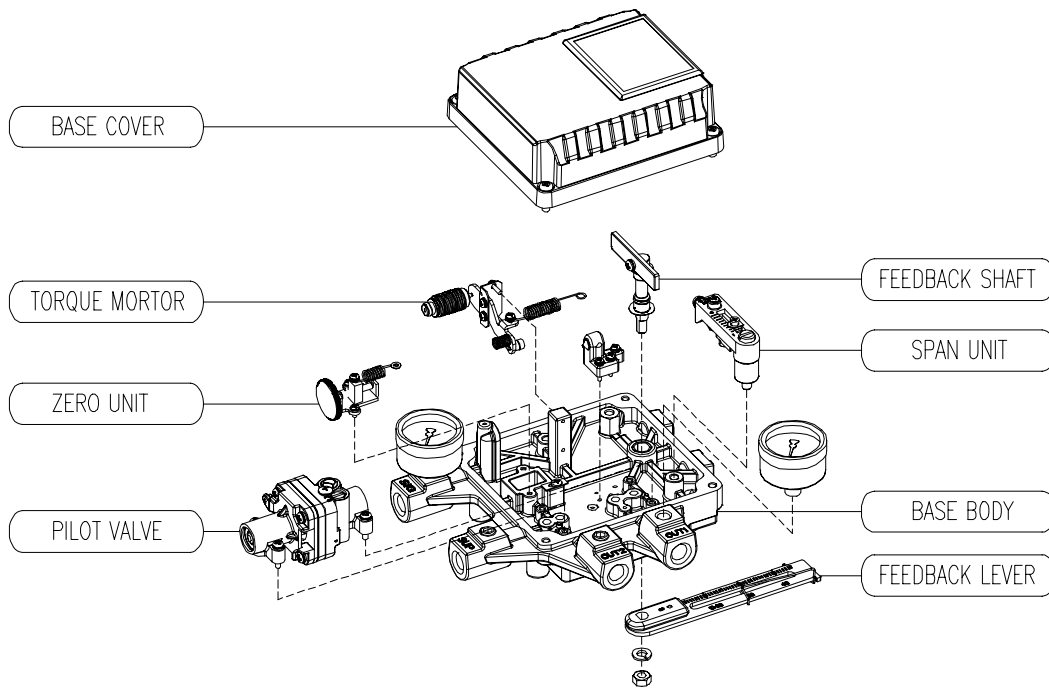

2.7.2 YT-1000R

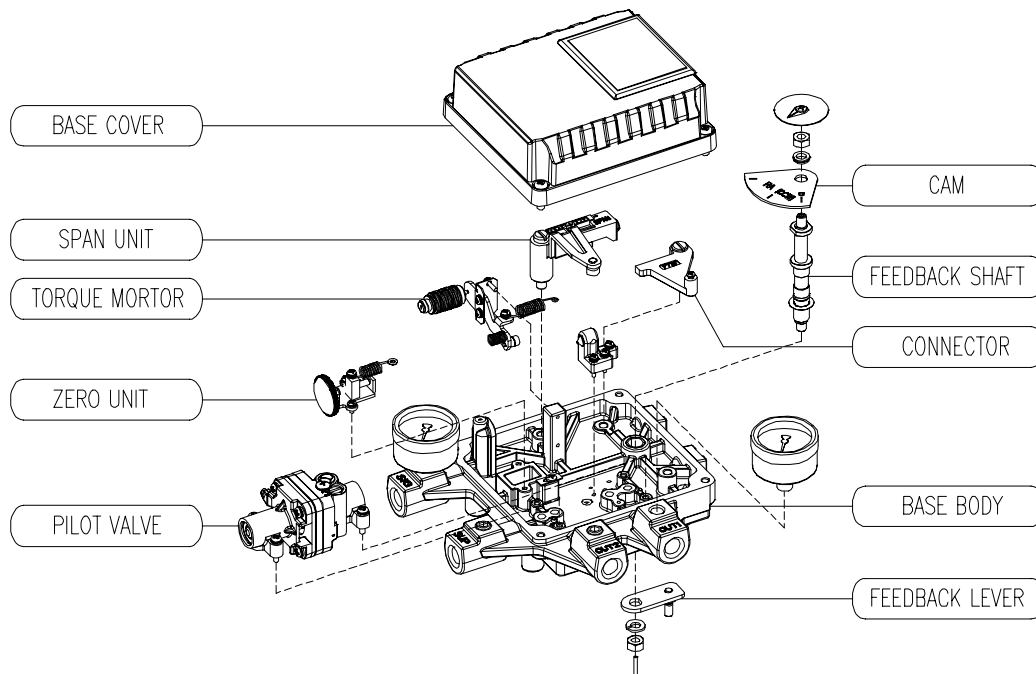

2.7.3 YT-1200R + SPTM-6V (External)

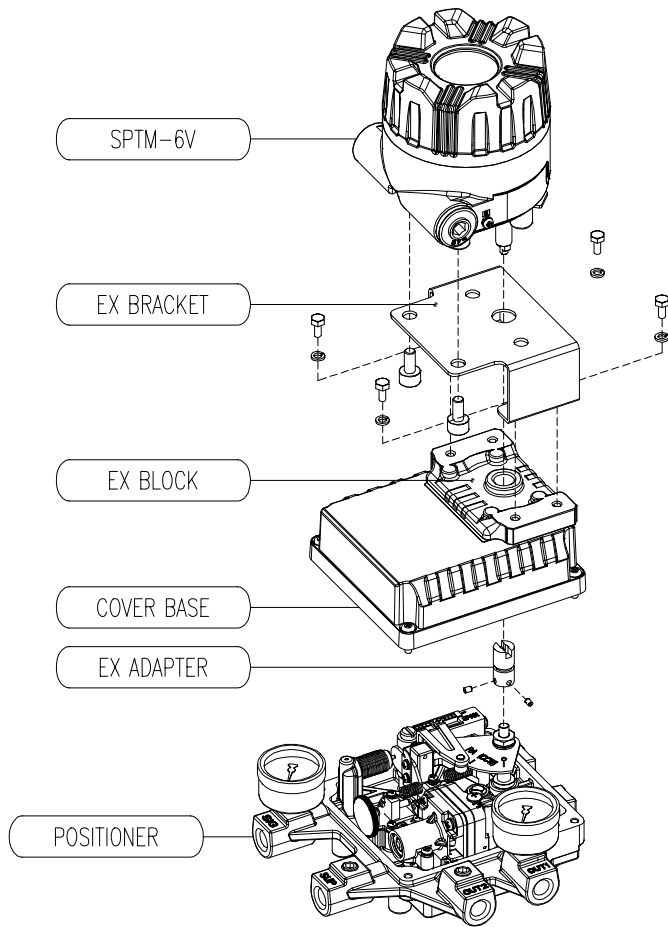

2.7.4 YT-1000R + YT-870 (External)

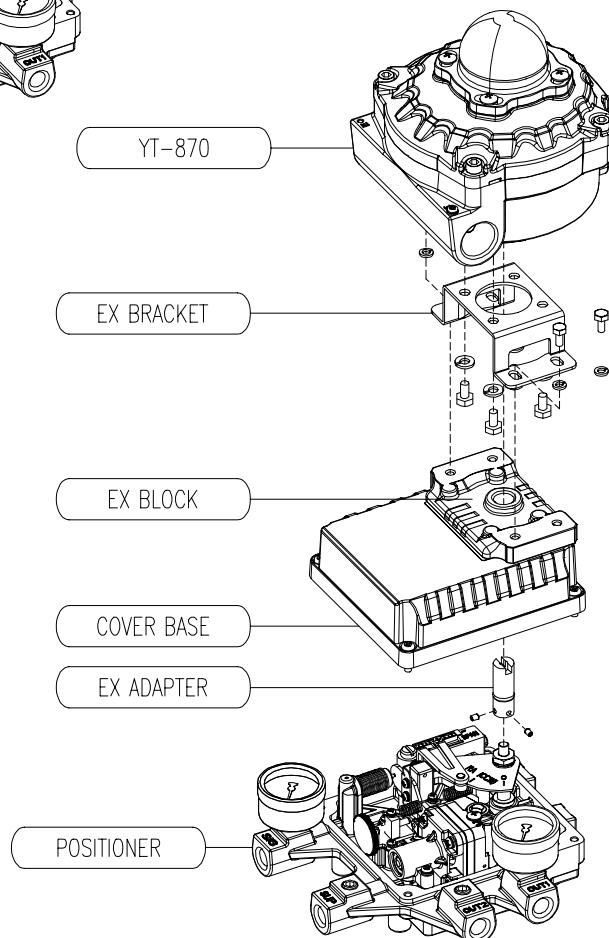

2.8 Product Dimension

2.8.1 YT-1200L

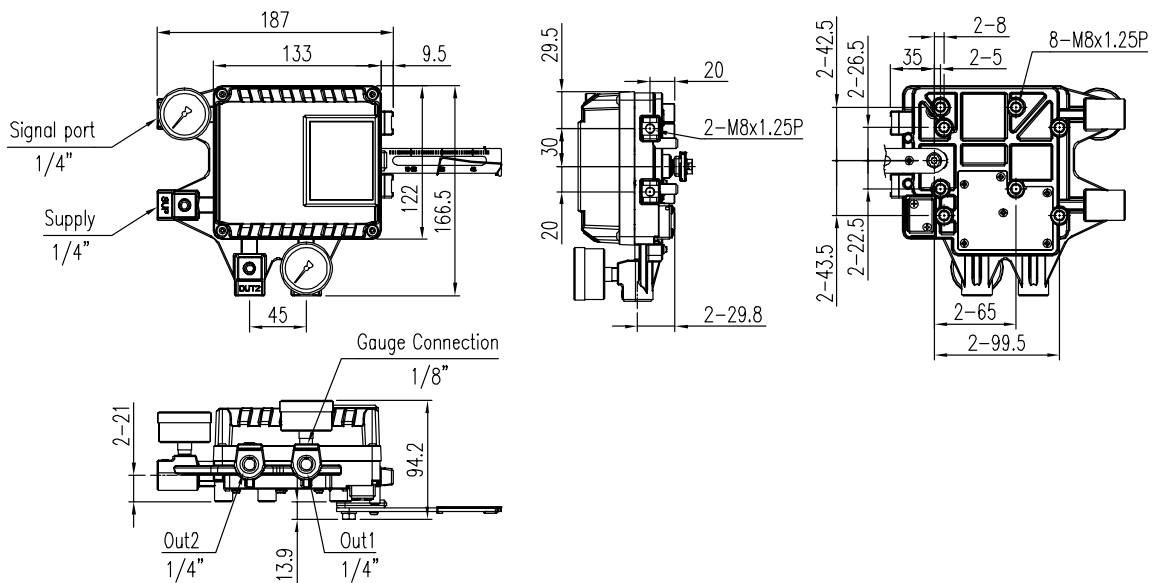

2.8.2 YT-1200R (Fork Lever type)

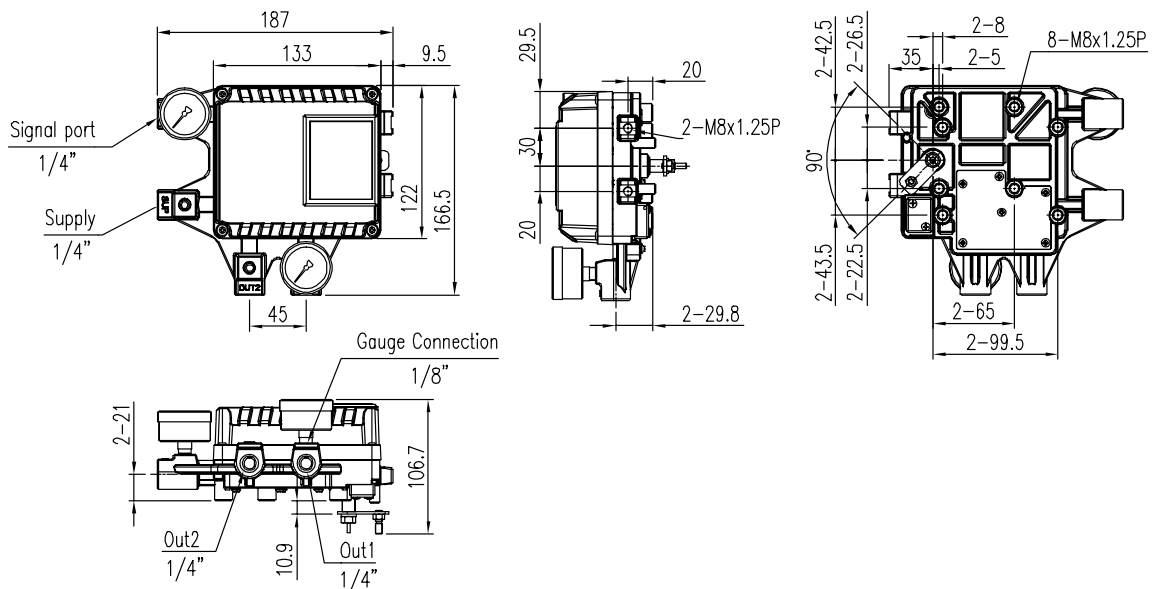

2.8.3 YT-1200R (Namur type)

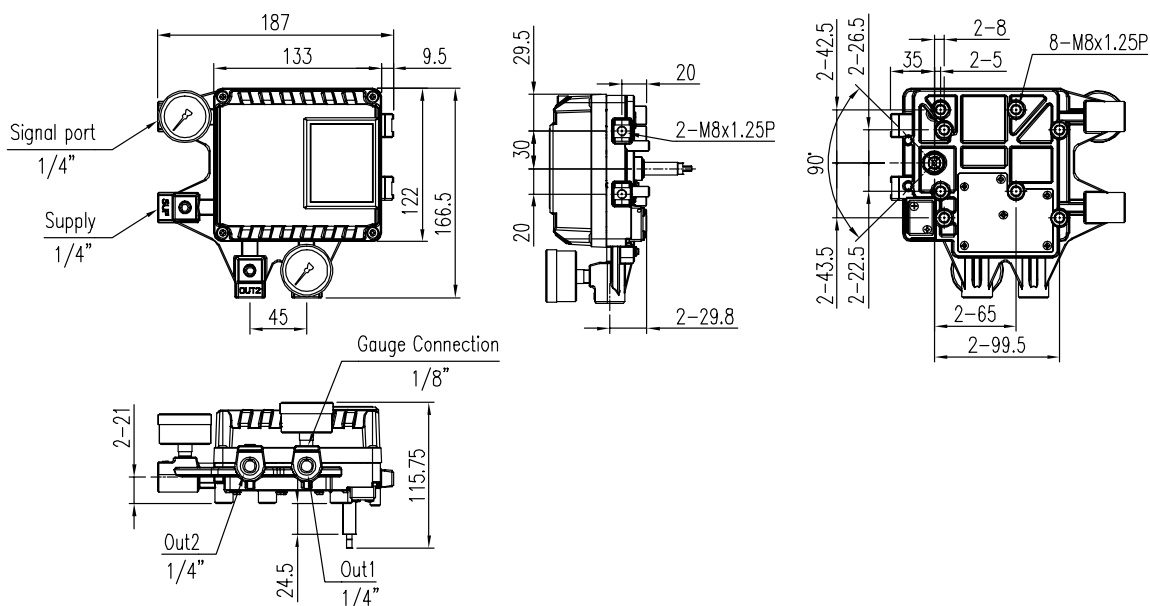

2.8.4 YT-1200R (Dome indicator)

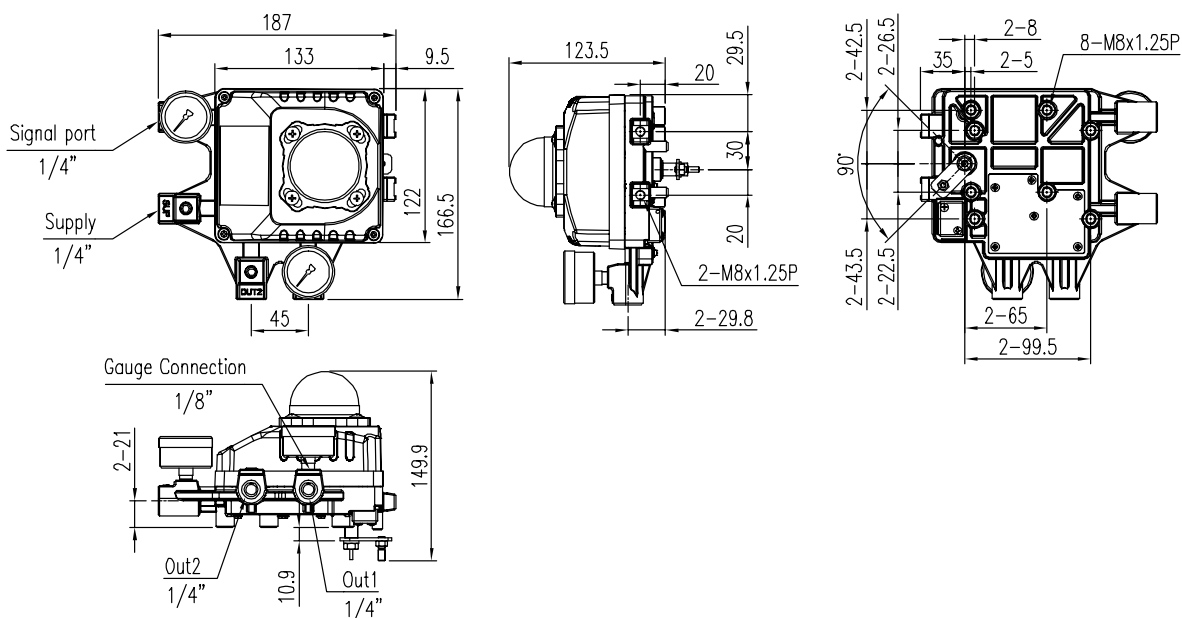

2.8.5 YT-1200R (External SPTM-6V)

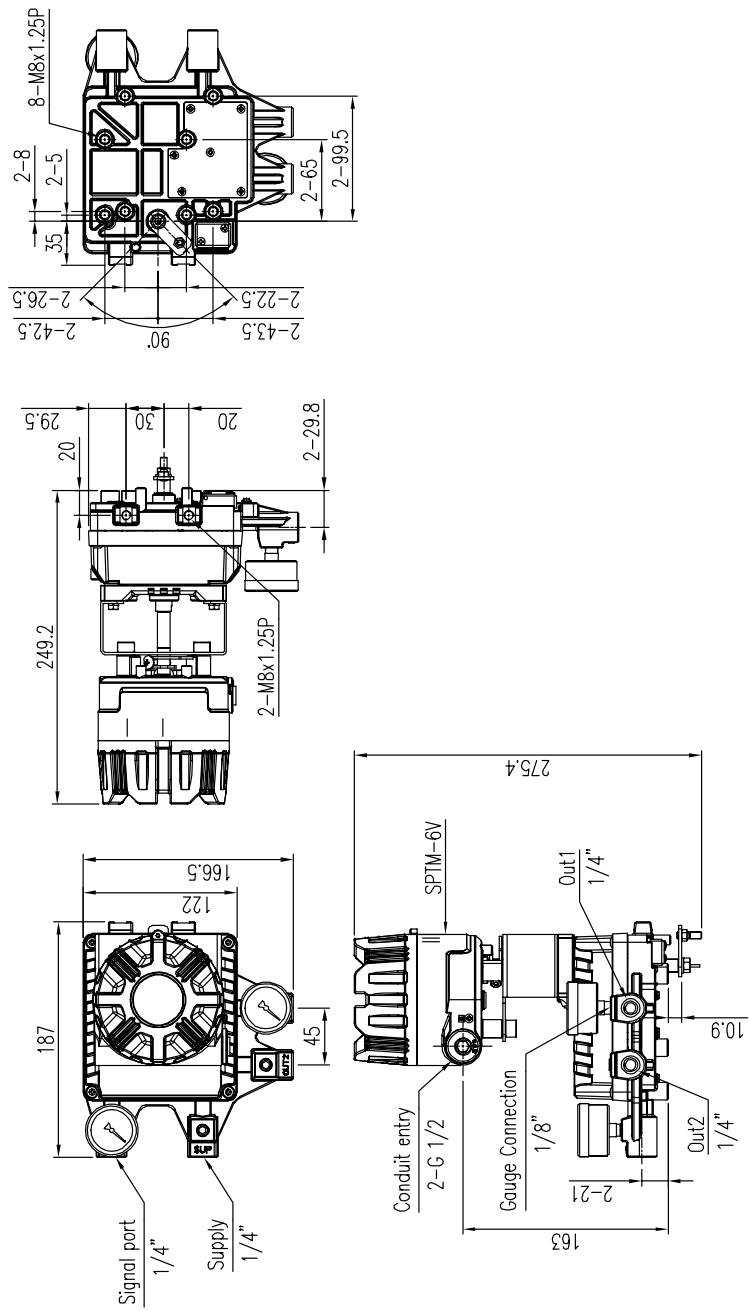

2.8.6 YT-1000R (External Limit Switch, YT-870)

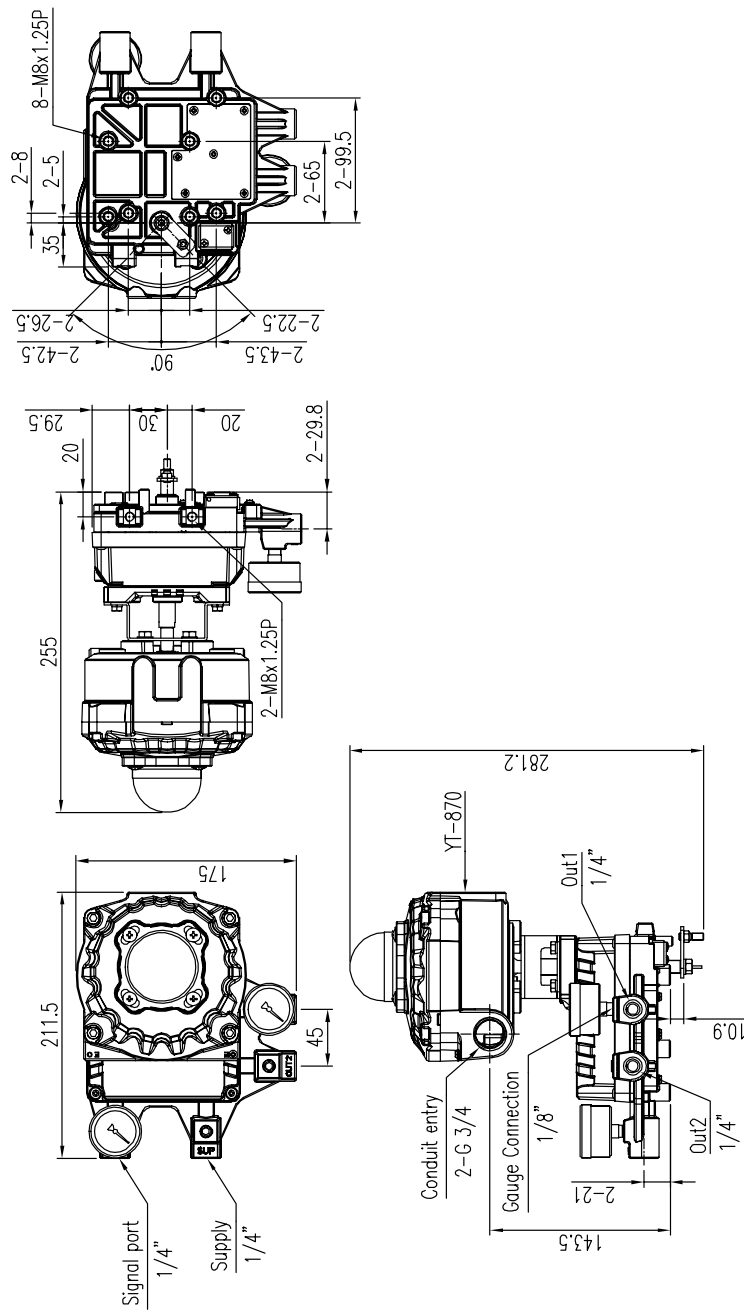

3 principle of positioner movement

3.1 Linear Positioner

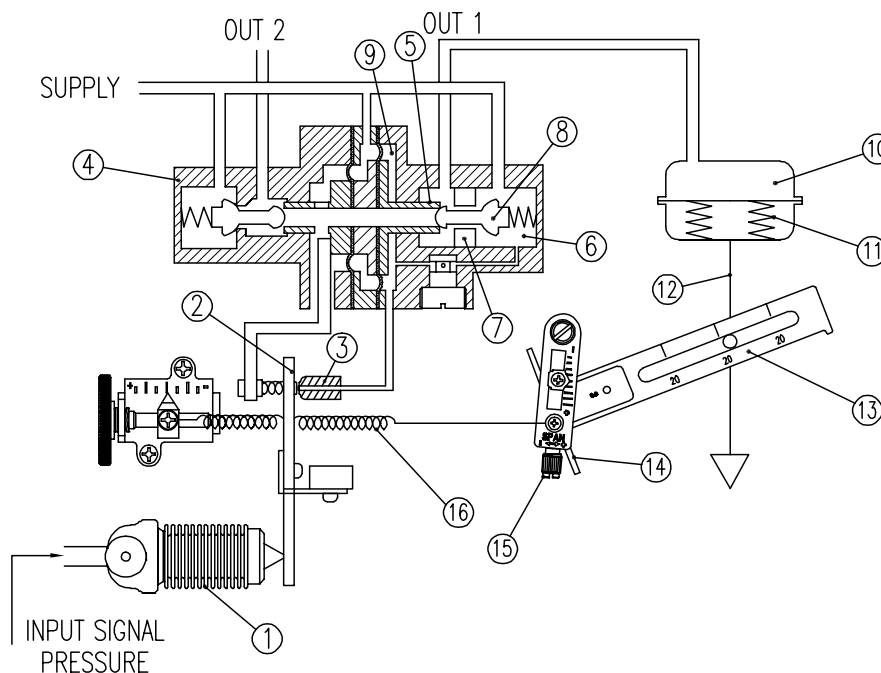

Fig. 3-1: Linear positioner with an actuator

When INPUT SIGNAL PRESSURE increases to open the valve, ① the bellows stretches and pushes ② the flapper to the opposite side of ③ the nozzle. The gap between ③ the nozzle and ② the flapper becomes wider and from inner part of ④ the pilot, air inside ⑨ the chamber is exhausted through ③ the nozzle. Due to this effect ⑤ the spool moves to the right. Then, ⑦ the seat which was blocked by ⑧ the poppet pushes the poppet away and supplied pressure (air) goes through ⑦ the seat and OUT1 Port and enters into ⑩ the chamber of the actuator. Then ⑩ chamber's pressure will increase and when there is enough pressure inside the chamber to push ⑪ the actuator's spring, ⑫ actuator's stem will start to go down and through the feedback lever, stem's linear motion will be converted to ⑭ span lever's rotary motion. This ⑭ span lever's rotary motion will then once again rotate ⑮ the span and pulls the spring. When the valve's position reaches to given input signal pressure, ⑯ span spring's pulling force and force of ① bellows will be balanced and move ② the flapper back its original position to reduce the gap between ③ the nozzle. The amount of air being exhausted through ③ the nozzle will reduce and ⑨ the chamber pressure will increase again. ⑤ Spool will move back to its original position on the left and ⑧ the poppet will also move in same direction blocking ⑦ the seat to stop the air coming into the ⑩ chamber through the SUPPLY. As a result, the actuator will stop operating and the positioner will return to its normal condition.

3.2 Rotary Positioner

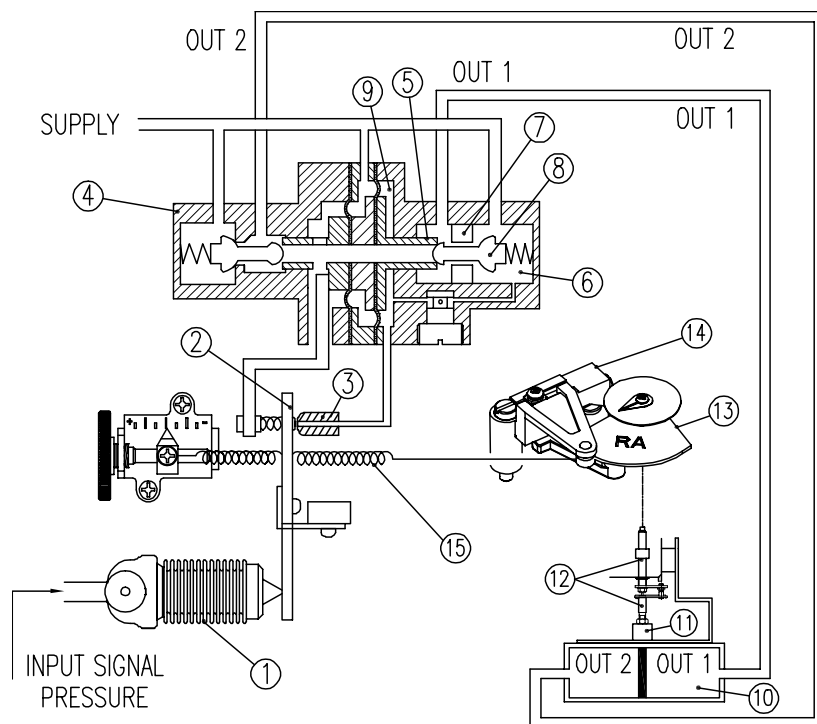

Fig. 3-2: Rotary positioner with an actuator

When INPUT SIGNAL PRESSURE increases to open the valve, the bellows stretches and pushes ② the flapper to the opposite side of ③ the nozzle. The gap between ③ the nozzle and ② the flapper becomes wider and from inner part of ④ the pilot, air inside ⑨ the chamber is exhausted through ③ the nozzle. Due to this effect ⑤ the spool moves to the right. Then, ⑦ the seat which was blocked by the poppet pushes ⑧ the poppet away and supplied pressure (air) goes through ⑦ the seat and OUT1 Port and enters into ⑩ the chamber of the actuator through OUT1. Then ⑩ chamber's OUT1 pressure will increase and ⑪ the actuator's stem will rotate and through ⑫ the feedback shaft, actuator's rotating motion will be transferred to ⑬ the cam. This motion will then rotate ⑭ the span lever and pull ⑮ the span's spring. Once it reaches to given input signal, ⑮ span spring's pulling force and force of ① bellows will be balanced and move ② the flapper back its original position to reduce the gap between ③ the nozzle. The amount of air being exhausted through ③ the nozzle will reduce and ⑨ chamber pressure will increase again. ⑤ Spool will move back to its original position on the left and ⑧ the poppet will also move in same direction blocking ⑦ the seat to stop the air coming into the ⑩ chamber through the SUPPLY. As a result, the actuator will stop operating and the positioner will return to its normal condition.

4 Installation

4.1 Safety

When installing a positioner, please ensure to read and follow safety instructions.



- Any input or supply pressures to valve, actuator, and / or to other related devices must be turned off.
- Use bypass valve or other supportive equipment to avoid entire system “shut down”.
- Ensure there is no remaining pressure in the actuator.
- The positioner has a vent cover to exhaust internal air and drain internal condensation water. When installing the positioner, make sure the vent cover must be facing downward. Otherwise, the condensation water could cause corrosions and damages to internal parts.

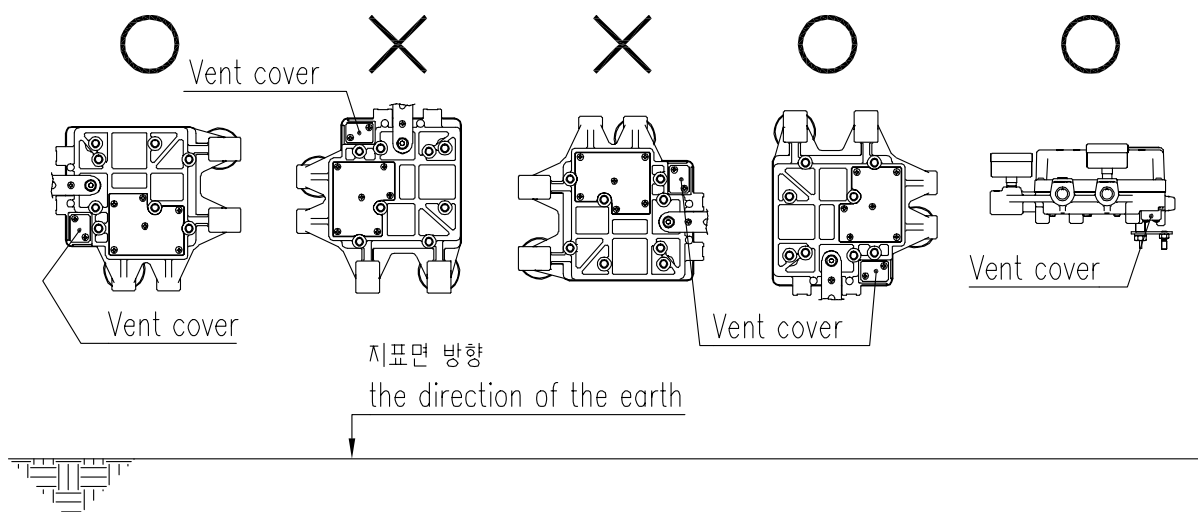

Fig. 4-1: The correct positions of a vent cover

4.2 Tools for installation

- Hex key set for hex socket cap bolts
- (+) & (-) Screw drivers
- Spanners for hexagonal-head bolts

4.3 Linear positioner Installation

Linear positioner should be installed on linear motion valves such as globe or gate type which uses spring return type diaphragm or piston actuators.

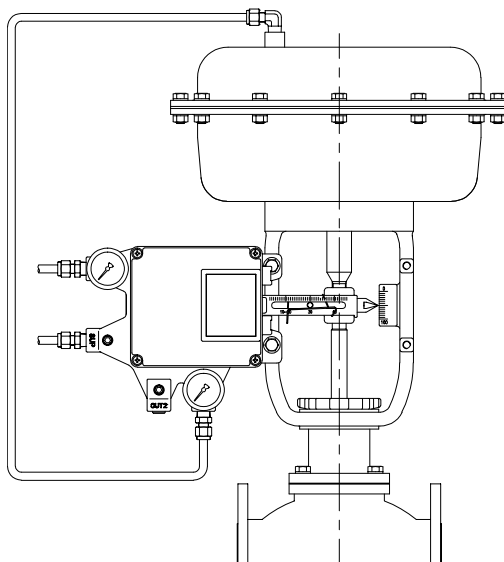

Fig. 4-2: Installation example

Before proceeding with the installation, ensure following components are available.

- Positioner
- Feedback lever and lever spring
- M6 nut and spring washer (fastening feedback lever to a main shaft)
- Bracket, bolts and washers for positioner – not supplied with the positioner
- Connection bar – not supplied with the positioner

4.3.1 Preparing Bracket for the positioner

Proper bracket must be made in order to adapt the positioner on the actuator yoke.

Please consider following important points when a bracket is being designed.

- Positioner's feedback lever must be vertical to the valve stem at 50 % of the valve stroke.
- The connection bar of the actuator clamp for the feedback lever should be installed in such a way that the valve stroke length coincides with the corresponding figure in "mm" marked on the feedback lever. Improper setting may cause poor linearity



4.3.2 Installation Steps

- 1) Assemble the positioner with the bracket made in previous step by fastening the bolts (M8 x 1.25P).

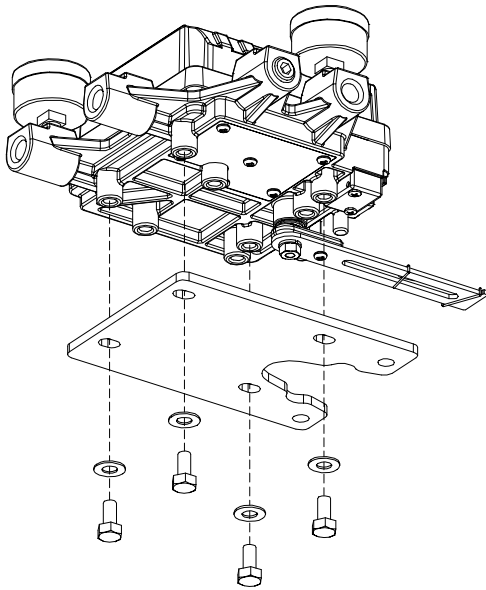

Fig. 4-3: Attaching positioner to bracket

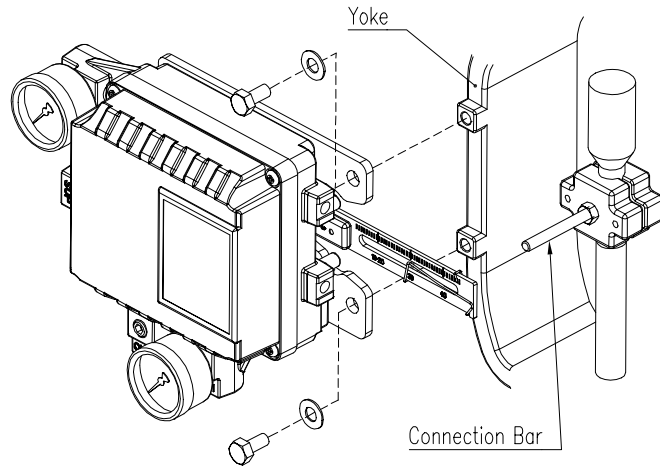

Fig. 4-4: Attaching the bracket to actuator yoke

- 2) Attach the positioner with the bracket to the actuator yoke
– **DO NOT TIGHTEN THE BRACKET COMPLETELY.**
- 3) Connect connection bar to the actuator clamp. The hole gap on the feedback lever is 6.5 mm so the connection bar's outer diameter should be less than 6 mm.

- 4) Connect an air-filter regulator to the actuator temporarily. Supply enough air pressure to the actuator in order to position the valve stroke at 50 % of the total stroke.

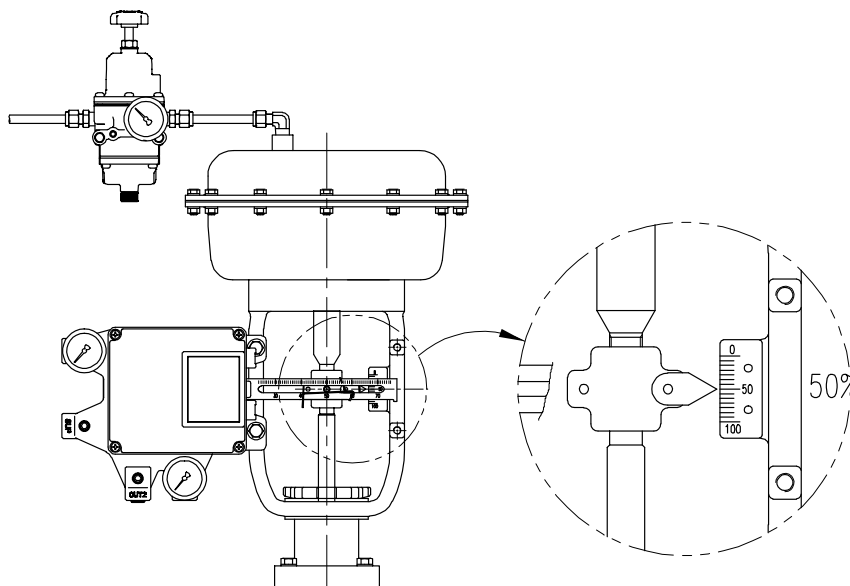

Fig. 4-5: Positioning the valve at 50 % of the total stroke

- 5) Insert the connection bar between the feedback lever and lever spring. The connection bar must be located upward from the lever spring as shown the below left figure. If it is located downward from the lever spring as shown the below right figure, the connection bar or the lever spring will be worn out quickly because of excessive strong tension.

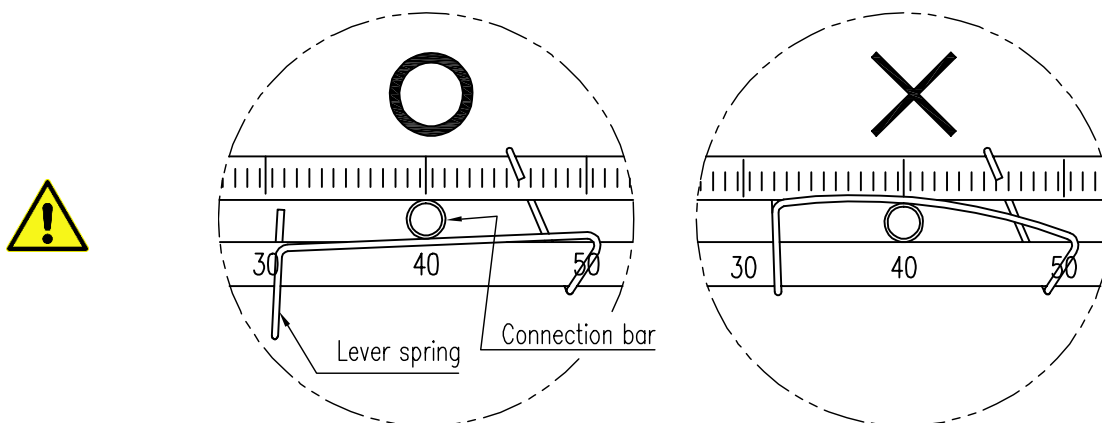

Fig. 4-6: Proper way to insert connection bar between feedback lever and lever spring

- 6) Check if feedback lever is vertical to the valve stem at 50 % of the valve stroke. If it is not vertical, adjust the bracket or the connection bar to make vertical. Improper installation may cause poor linearity.

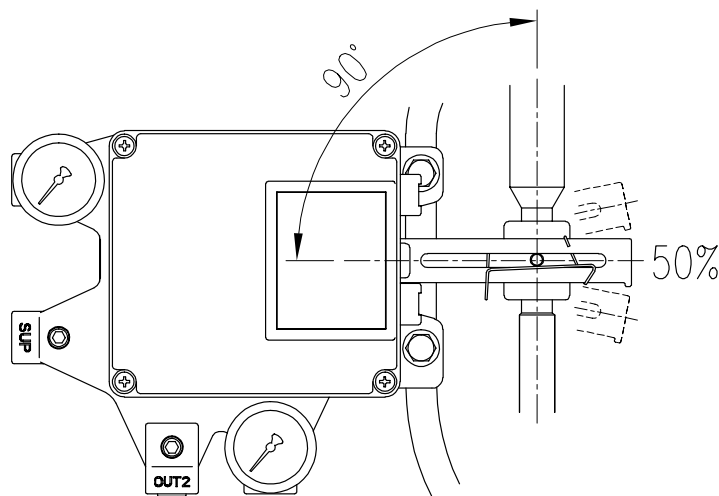

Fig. 4-7: Feedback lever and valve stem

- 7) Check the valve stroke. The stroke numbers are engraved on the feedback lever of the positioner. Position the connection bar at the number on the feedback lever which corresponds with the desired valve stroke. To adjust, move the bracket, the connection bar or both.

※ The effective linear lever angle is 23 degree.

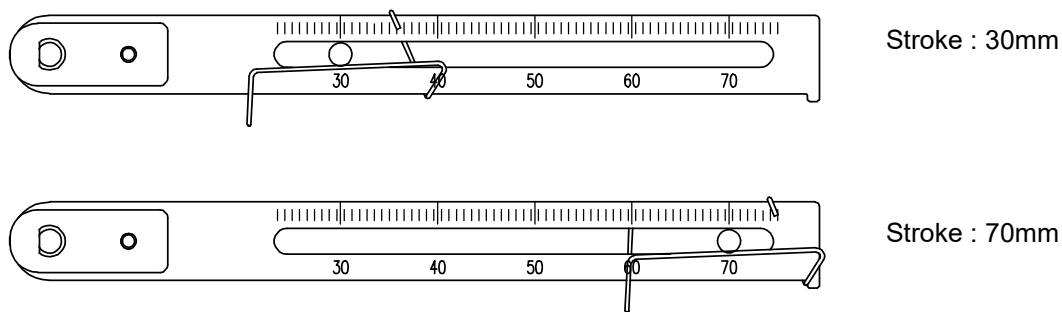

Fig. 4-8: Feedback lever and location of the connection bar



- 8) After installing the positioner, operate the valve from 0 % to 100 % stroke by using direct air to the actuator. On both 0 % and 100 %, the linear lever stopper should not touch the stopping bosses of positioner, which is located on the backside of the positioner. If the linear lever stopper touches the stopping bosses, the positioner should be installed further away from center of the actuator.

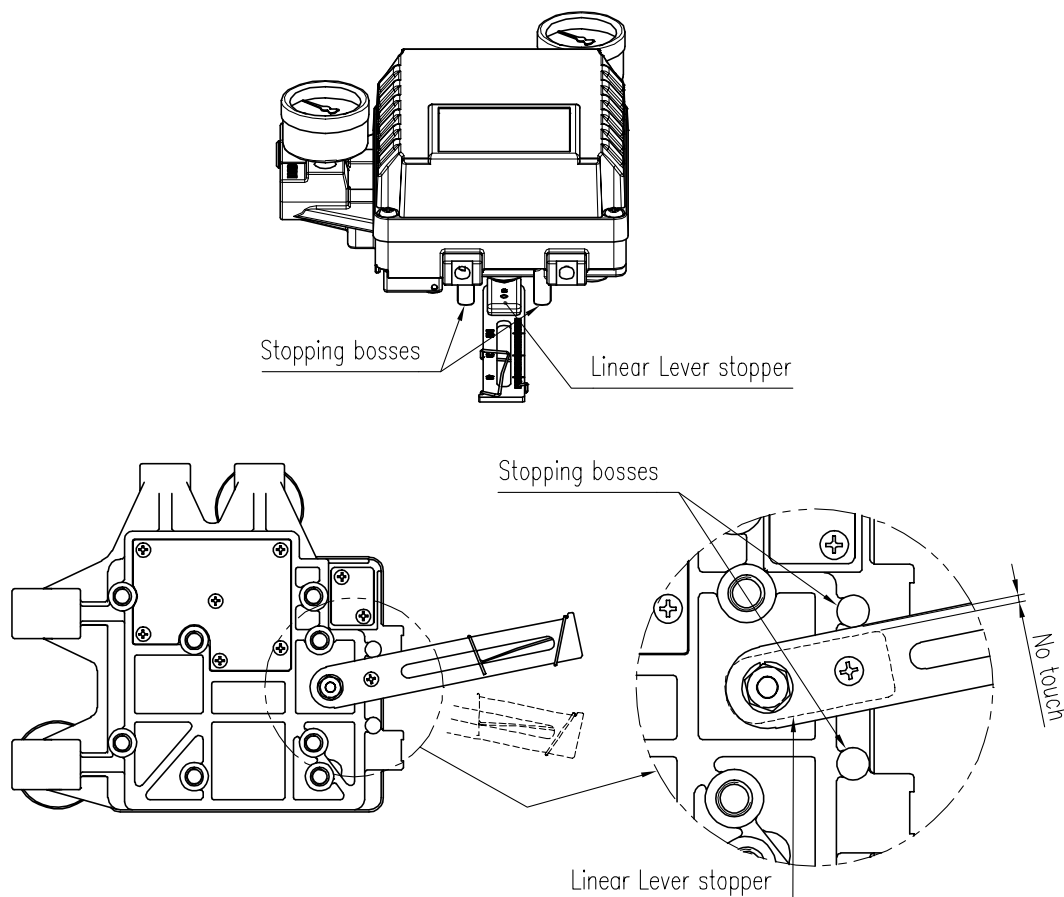

Fig. 4-9: Linear lever stopper should not touch stopping bosses of positioner on 0 % to 100 % valve stroke.

- 9) After the installation, tighten all of the bolts or nuts on the bracket and the connection bar.

4.4 Rotary positioner Installation

Rotary positioner should be installed on rotary motion valve such as ball or butterfly type which uses rack and pinion, scotch yoke or other type of actuators which its stem rotates 90 degrees. Before proceeding with the installation, ensure following components are available.

4.4.1 Components

- Positioner
- Fork lever (Only Fork lever type)
- Rotary bracket set (3 pieces)
- 4 pcs x hexagonal headed bolts (M8 x 1.25P x 15L) : For the positioner and the upper bracket
- 4 pcs x M8 plate washers : For the positioner and the upper bracket
- 4 pcs x wrench headed bolts (M6 x 1P x 15L) : For the brackets
- 4 pcs x M6 nuts : For the brackets
- 4 pcs x M6 spring washers : For the brackets
- Bolts and washers to attach the lower bracket to actuator – not supplied with the positioner

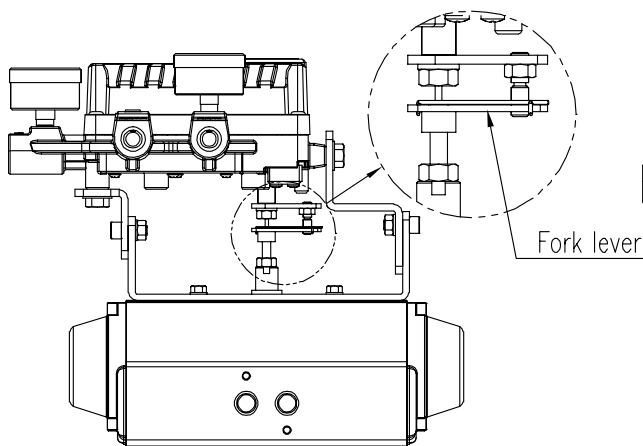

Fig. 4-10: Fork lever type

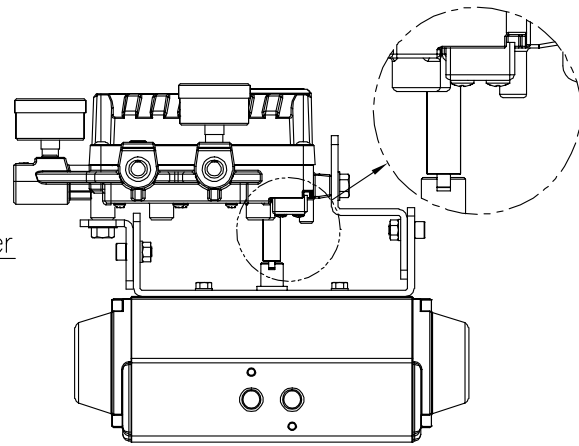

Fig. 4-11: Namur type

4.4.2 Rotary Bracket Information



The rotary bracket set (included with the positioner) contains three components. The bracket is designed to fit onto the actuator with 20 mm, 30 mm and 50 mm stem height (H) according to VDI/VE 3845 standard. Please refer to below figures how to adjust the height of the bracket.

YT-1200R Bracket Assembly Method

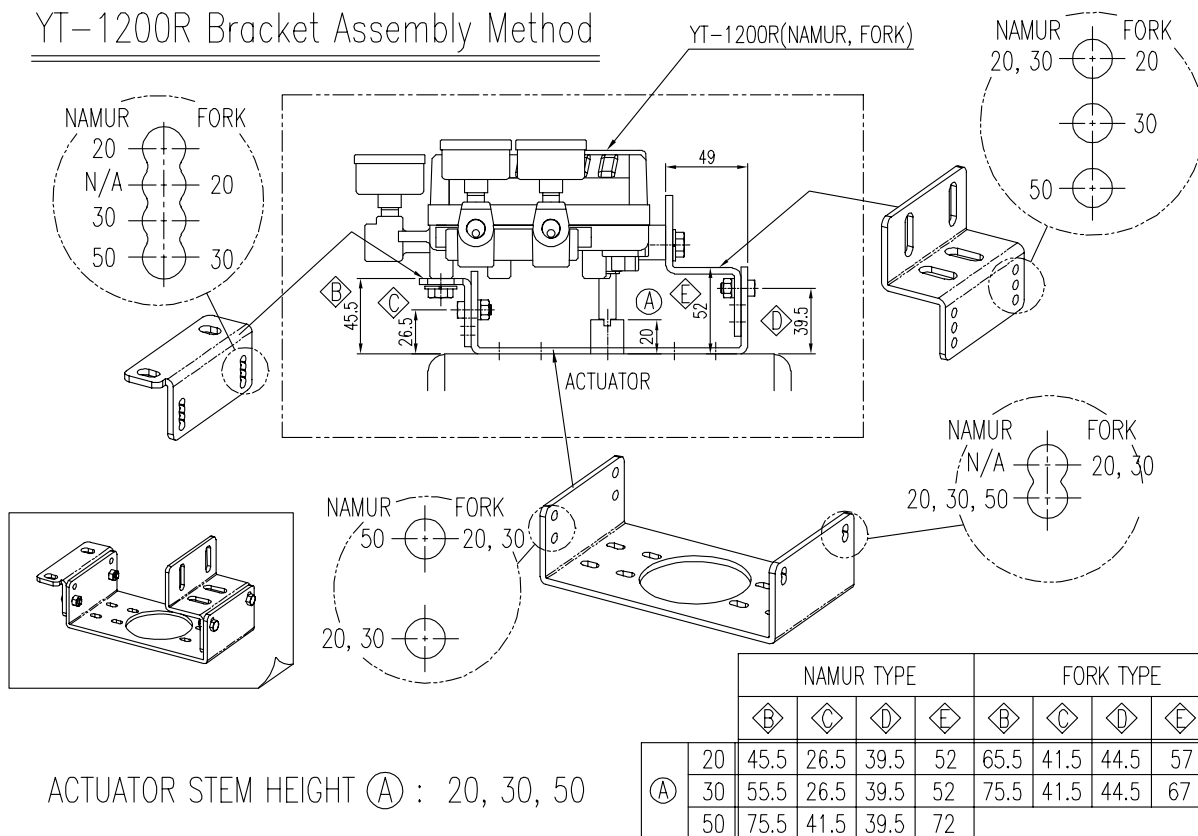

ACTUATOR STEM HEIGHT (A) : 20, 30, 50

Fig. 4-12: Brackets and positioner

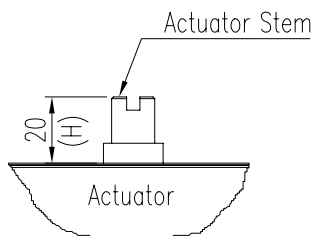

Fig. 4-13: Actuator stem Height

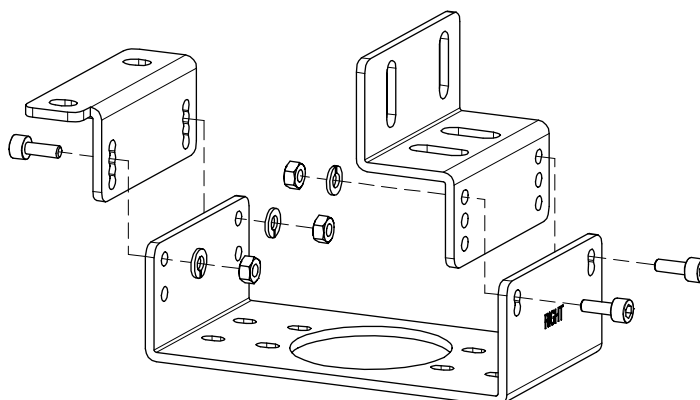



Fig. 4-14: Rotary Brackets Assembly

4.4.3 Rotary positioner Installation Steps

- 1) Please check the actuator's stem height and adjust the brackets by referring to the above bracket figures.
- 2) Attached the brackets onto the actuator. It is recommended to use spring washer so the bolts will not be loosen from vibration.
- 3)  Set rotation position of the actuator stem at 0 %. For single acting actuator, it is easy to check 0 % point by supplying no pressure to the actuator. For double acting actuator, check actuator stem's rotation direction – clockwise or counter-clockwise - by supplying pressure to the actuator.
- 4) (Only Fork lever type) Install the fork lever after setting actuator's stem at 0 %. Check the actuator stem's rotation direction – clockwise or counter-clockwise.
Installation angle of the fork lever should be 45° to the longitudinal direction of the actuator.

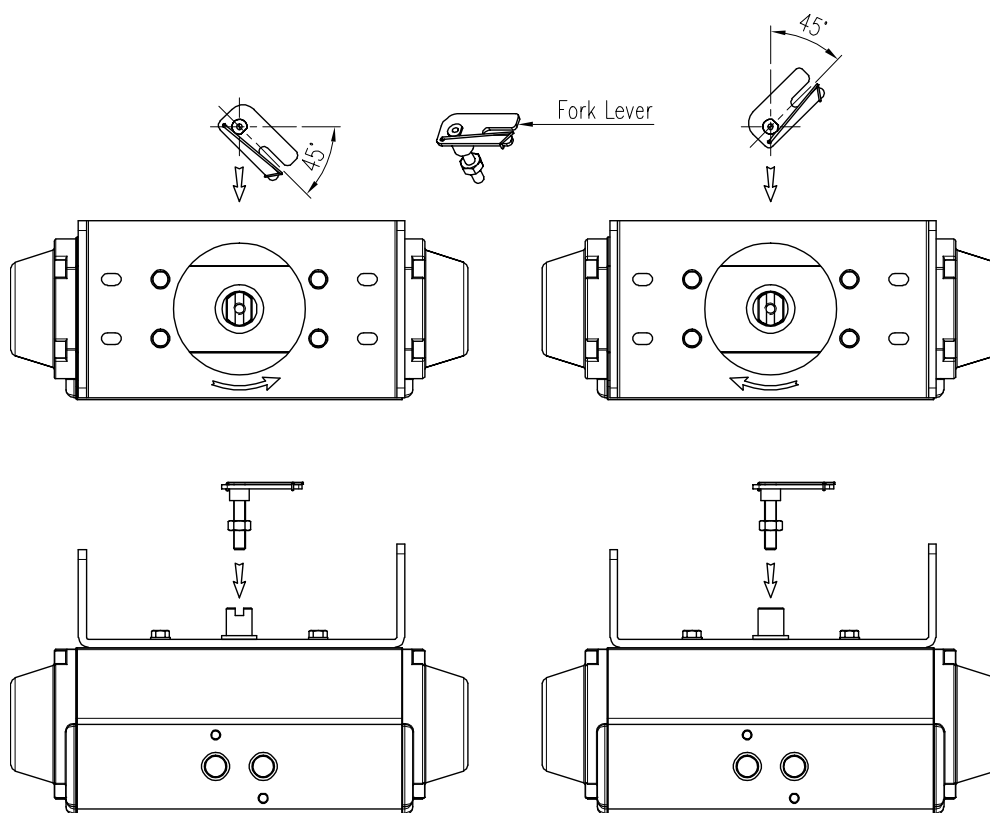

Fig. 4-15: Counter-clockwise and clockwise rotation.



- 5) (Only Fork lever type) After determining fork lever direction, adjust F between the top plate of fork lever and the top face of actuator as below table. Fasten lock nuts which are located on the bottom of the fork lever.

H	F (only No. 1 & 3 fork lever)
20	About 44
30	About 54
50	About 74

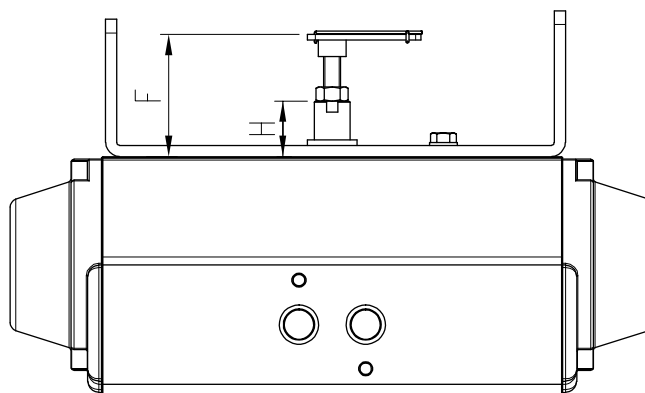

Fig. 4-16: Height of fork lever



- 6) Attach the positioner to the bracket. <Only fork lever type : Fix the clamping pin (5 mm Dia.) into the fork lever slot and insert center pin (2 mm Dia.) of the main shaft of the positioner into the hole of center of the fork lever. The clamping pin will be locked to the fork lever spring.> Setting alignment of center of main shaft of the positioner and center of the actuator's stem is very important. Poor alignment of the main shaft and the actuator's stem decreases the positioner's durability due to unnecessary forces on the main shaft.

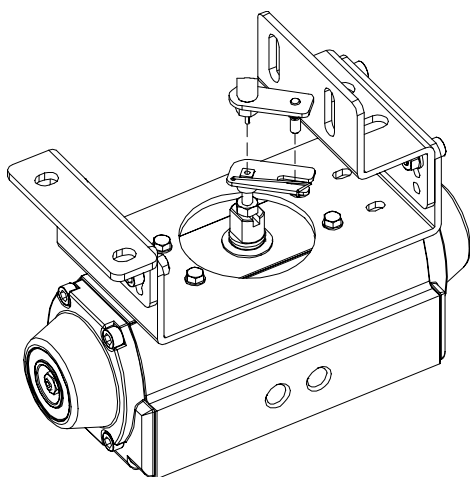

Fig. 4-17: Main shaft center alignment (Fork lever)

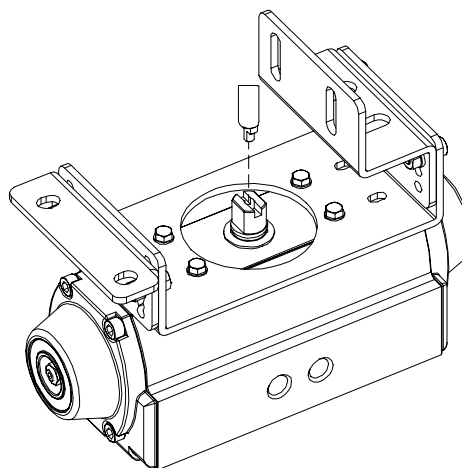

Fig. 4-18: Main shaft center alignment (Namur)

- 7) Tighten the positioner and the bracket with bolts **after checking the positioner's position.**

5 Connection - Air

5.1 Safety

- Supply pressure should be clean and dry air – avoiding moisture, oil and dust.
- Always recommended to use air filter regulator (i.e. YT-200 series).
- Rotork YTC Limited **has not tested positioner's operation with any other gases other than clean air. Please contact Rotork YTC Limited for any questions.**

5.2 Supply Pressure Condition



- Dry air with dew point of at least 10 °C lower than ambient temperature.
- Avoid from dusty air. Use 5 micron or smaller filter.
- Avoid oil.
- Comply with ISO 8573-1 or ISA 7.0.01.
- Supply pressure range is 0.14 to 0.7 MPa (1.4 to 7 bar)
- Set air filter regulator's pressure level 10 % higher than actuator's spring range pressure.

5.3 Piping Condition



- Ensure inside of pipe is clean of obstructions.
- Do not use pipeline that is squeezed or shows any type of damamges.
- Pipeline should have more than 6 mm of inner diameter (10 mm outer diameter) to maintain flow rate.
- The length of pipeline system should not be extremely long. Longer pipeline system may affect flow rate due to the friction inside of the pipeline.

5.4 Connection – Piping with actuator

5.4.1 Single acting actuator

Single acting type positioner is set to use only Out1 port. Out1 port of positioner should be connected with port of actuator when using spring return actuator of single acting type.

As input signal ampere increases, the supply air pressure will be supplied through Out1 port.

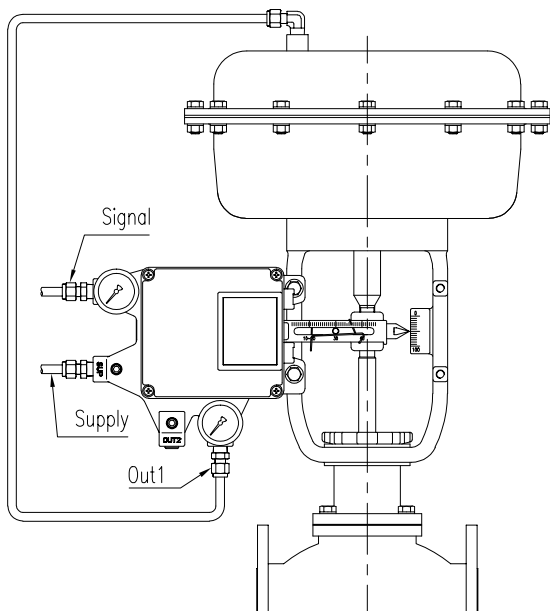

Fig. 5-1: Single acting linear actuator

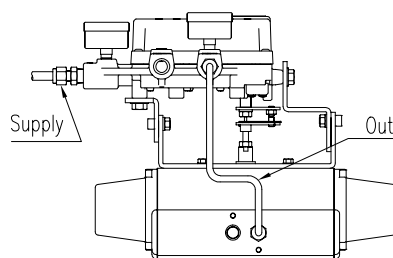

Fig. 5-2: Single acting rotary actuator

Refer to below diagram and check whether if the valve is a “Reverse Acting” or “Direct Acting”. Then connect positioner’s OUT1 port to the proper actuator’s port and in case of need, switch the assembly position of the Span (Linear) and Cam (Rotary).

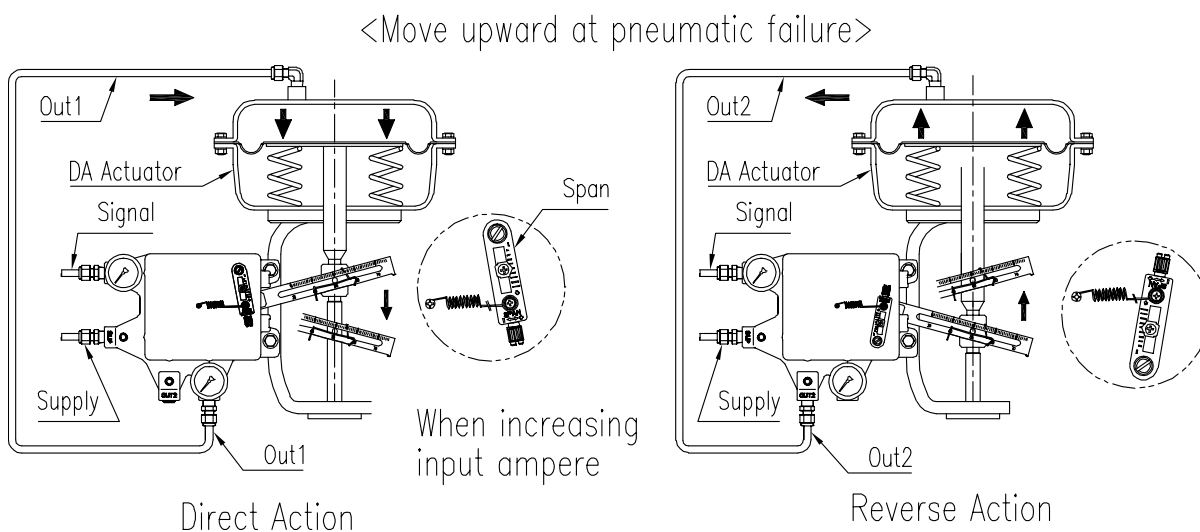

Fig. 5-3: Setting directions of piping and span for linear DA single actuator

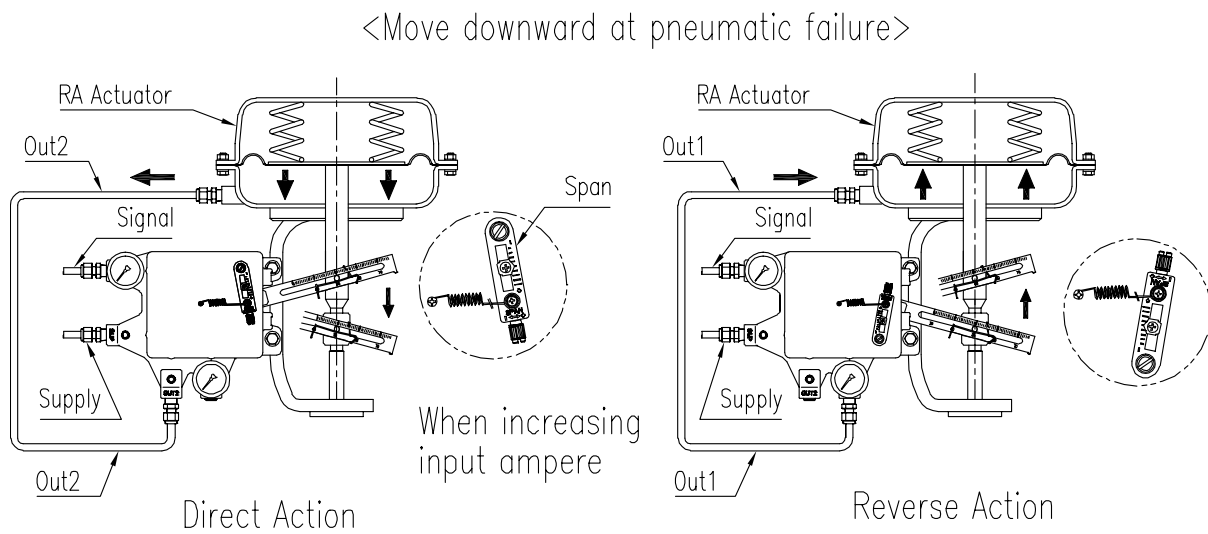

Fig. 5-4: Setting directions of piping and span for linear RA single actuator

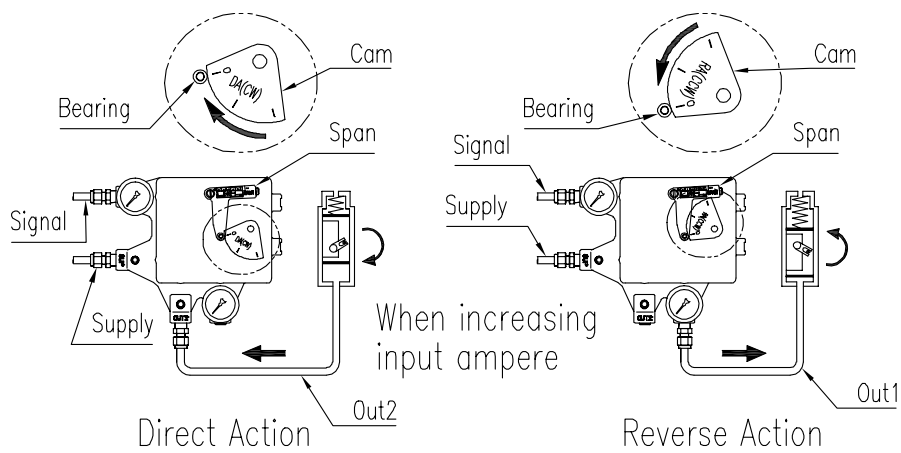

Fig. 5-5: Setting directions of piping and cam for rotary single actuator

5.4.2 Double acting actuator

Double acting type positioner is set to use both Out1 and Out2 port. As input signal increases, the supply pressure will be supplied through Out1 of positioner to actuator and the exhausting air from actuator will be exhausted through Out2 of positioner.

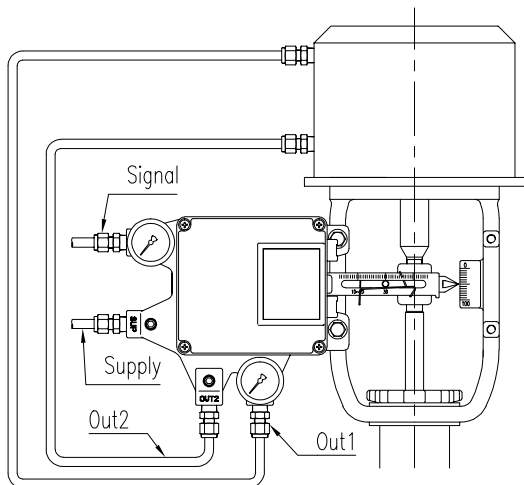

Fig. 5-6: Double acting linear actuator

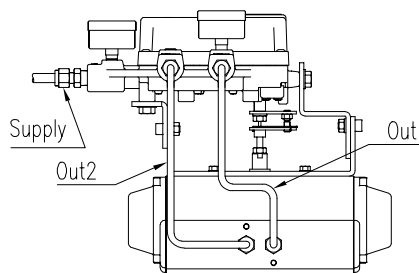

Fig. 5-7: Double acting rotary actuator

Refer to below diagram and check if the valve is a “Reverse Acting” or “Direct Acting”. Then connect positioner’s OUT1 port to the proper actuator’s port and in case of need, switch the assembly position of the Span (linear) and Cam (Rotary).

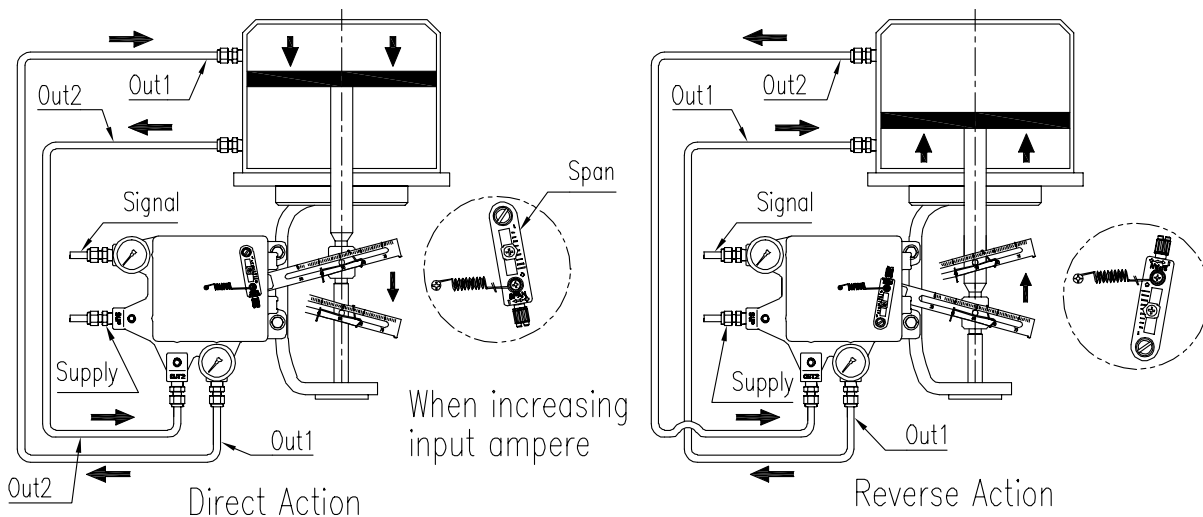

Fig. 5-8: Setting directions of piping and cam for linear double actuator

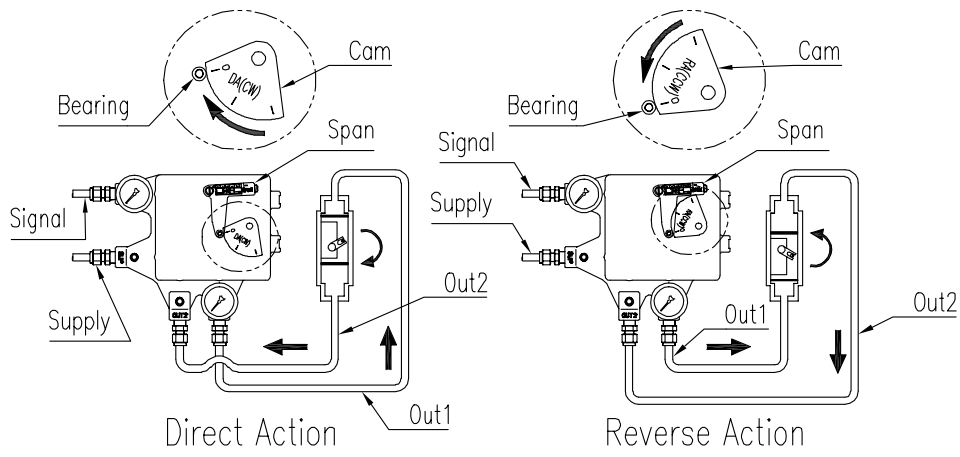

Fig. 5-9: Setting directions of piping and cam for rotary double actuator

6 Adjustments

6.1 Ra or Da Setting

6.1.1 Linear Positioner

- 1) If the actuator axis moves down when input signal is increased, assemble the "Span" to upper M6 Tap hole like the below figure.(DA)

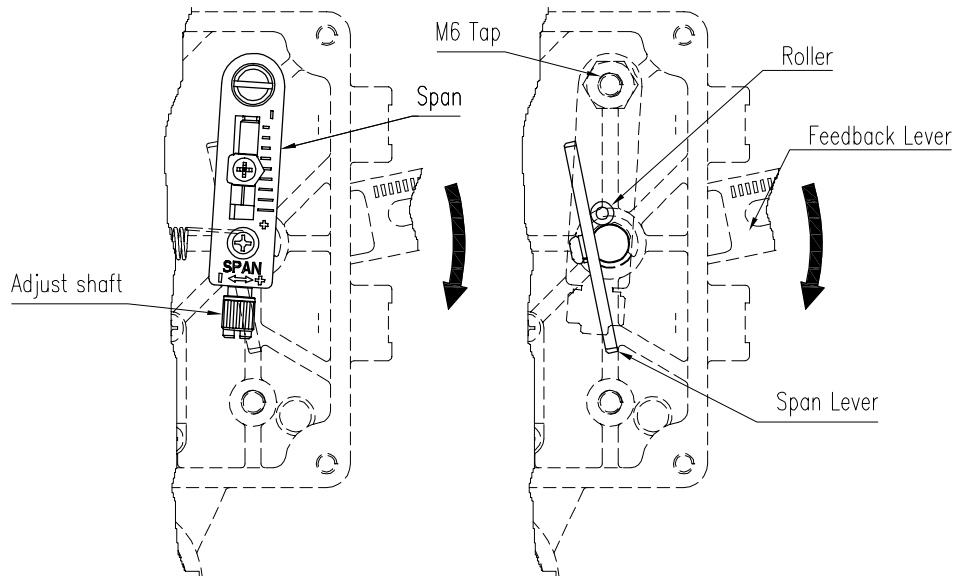

Fig. 6-1: Span Installation (DA)

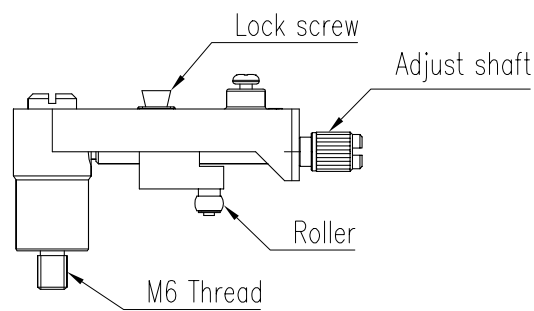

Fig. 6-2: Linear span assembly

- 2) If the actuator axis moves up when input signal is increased, assemble the “Span” to lower M6 Tap hole like the below figure.(RA)

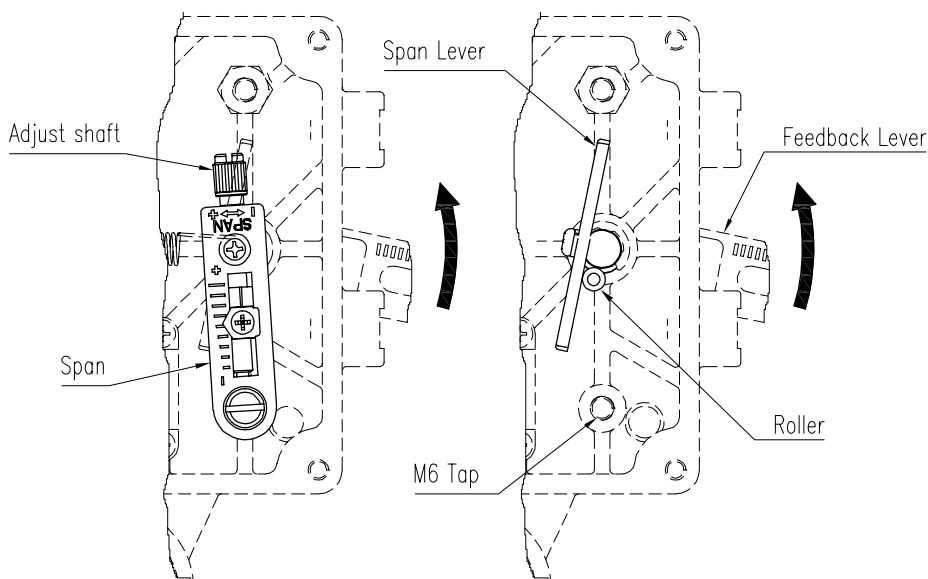

Fig. 6-3: Span Installation (RA)

6.1.2 Rotary positioner

- 1) If the actuator axis rotates clockwise when input signal is increased, in case of need, re-assemble the CAM so that “DA(Direct Acting)” lettered surface is facing upward.
- 2) If the actuator axis rotates counter-clockwise when input signal is increased, in case of need, re-assemble the CAM so that “RA(Reverse Acting)” lettered surface is facing upward.
- 3) Position the actuator to initial point.
- 4) Adjust the CAM so that the engraved CAM reference line marked with “0” is placed in the center of the span bearing and fix it by tightening the nut.

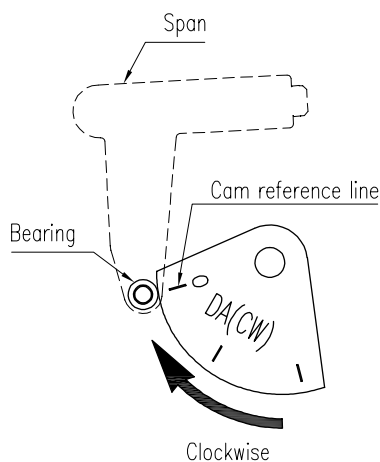

Fig. 6-4: Cam Installment (Da)

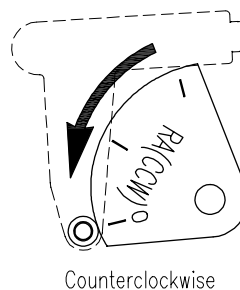

Fig. 6-5: Cam Installment (Ra)

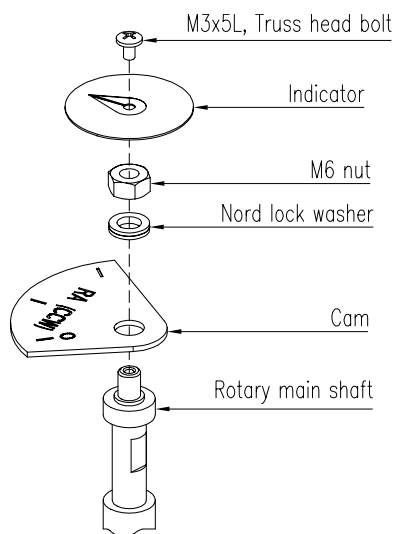

Fig. 6-6: Parts (Standard)

6.2 Adjustment - Zero Point and Span (Calibration)

Zero point adjustment and span adjustment (calibration) ensure that the actuator operates in the desired range and exact position relative to the input signal.

6.2.1 Precautions before zero point adjustment and span adjustment

- 1) When installing the positioner on the actuator, you must always perform zero point adjustment and span adjustment. Even when removing and reattaching the positioner from the same actuator, zero adjustment and span adjustment must be performed.
- 2) Since zero point adjustment and span adjustment are related to each other, if you adjust either one, the other must be adjusted again.
- 3) If the installation direction, temperature, supply pressure, etc. of the positioner change, check whether there is any problem with the zero point and span.
- 4) Even when driving after leaving it for a long time, check whether there is any problem with zero point and span.
- 5) Check whether the SUPPLY, OUT1, and OUT2 pipes are connected properly.
- 6) Check whether the input signal wires +, - and ground are connected properly.
- 7) Check whether the connection of the positioner, actuator, and feedback unit is solid.
- 8) Make sure the auto manual switch is locked clockwise (direction A).
- 9) Check whether RA and DA settings are correct.

6.2.2 Adjustment steps

- 1) Set the input current to 0% (standard specification is 4mA) and turn the wheel of the zero unit so that the actuator position is 0%.

- ※ If you turn the wheel in the downward “+” direction, the origin of the actuator will rise, and if you turn it in the upward “-” direction, it will be reversed.

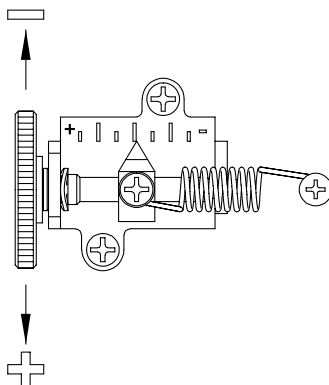

Fig. 6-7: Zero unit

- 2) Next, set the input current to 100% (standard specification is 20mA) and check whether the actuator position is 100%. If the position of the actuator is not 100%, loosen the span lock screw and adjust the span handle to set it to 100%.

- ※ Turning the wheel in the “+” direction widens the span of the actuator, and turning it in the “-” direction narrows the span.

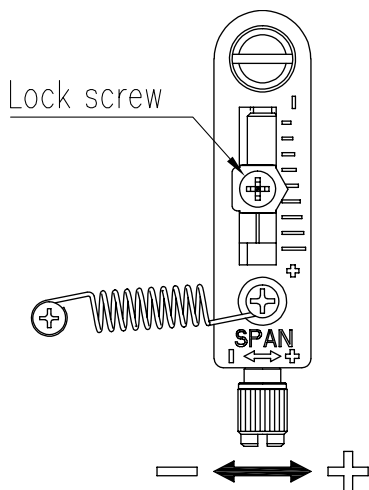

Fig. 6-8: Linear span unit

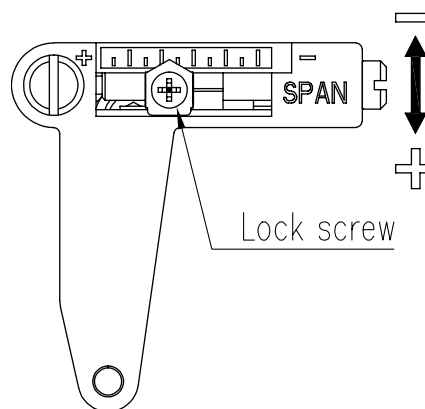

Fig. 6-9: Rotary span unit

- 3) Set the input current to 0% again and check whether the actuator position is 0%. If not, repeat steps 1 and 2 above.
- 4) Check whether the actuator reaches the same % position when the current is set to 25%, 50%, 75%, and 100%, respectively. If not, repeat steps 1-3.
- 5) After adjusting the position of the actuator relative to the input current, lock the lock screw of the span unit.

6.3 Adjustment – A/M switch (Auto/Manual)

- 1) Auto manual switch is on the top of pilot unit. Auto manual switch allows the positioner to be functioned as by-pass. If the counter-clockwise (toward “M”, Manual), it is loosened, then the supply pressure will be directly supplied from out1 port of positioner to the actuator regardless of input signal pressure. On the other hand, if the switch is turned clockwise (toward “A”, Auto) and it is fasten tightly, then the positioner will operate normally by input signal ampere. It is extremely important to check the allowed pressure level of the actuator when the switch is loosened.
- 2) Check whether the supply pressure is too high.
- 3) After using “Manual” function, auto manual switch should be returned to “Auto”.

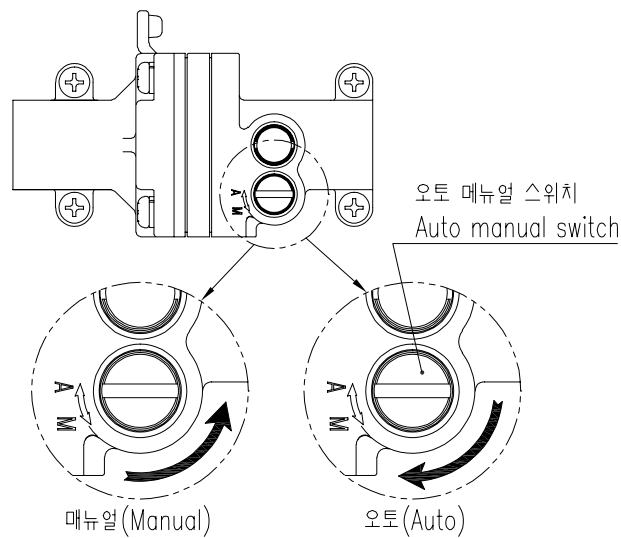

Fig. 6-10: A/M switch adjustment

6.4 Orifice Installment

If the actuator size is too small relative to the flow rate of positioner, hunting can occur. In order to avoid hunting, the orifices can be installed in the outports of the pilot.

- 1) Separate the pilot unit from the positioner.
- 2) Separate the o-rings from out1 and out2 ports, and insert the orifices. Before re-assemble the o-rings, please make sure there is no remaining dust or particles on the ports.
- 3) Standard diameter of the orifice hole are 1 mm. 2 mm diameter orifice can be ordered.

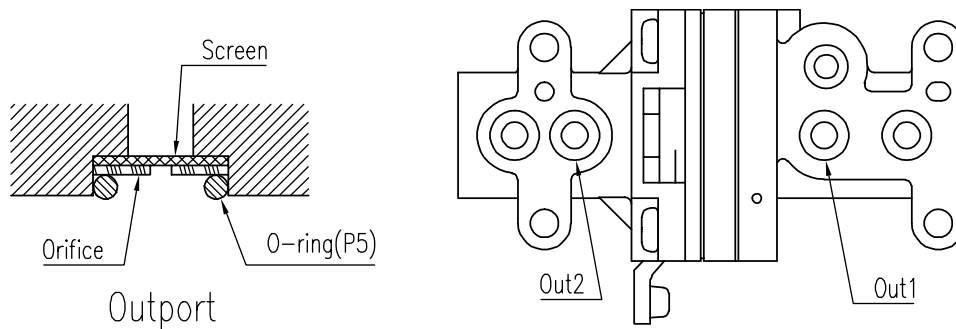

Fig. 6-11: Installing orifices

7 Maintenance

7.1 Pilot valve

- 1) If Supply air pressure is not stable or Supply air is not clean, the positioner may not function properly. Air quality and pressure should be checked regularly to see if the air is clean and pressure set is normal.
- 2) If the pilot valve has to be removed from the unit, be cautious not to lose the O-ring attached to rear side of the pilot valve and the stabilizing spring between the pilot valve and the torque motor.
- 3) On the back of the Auto Manual switch, there is a fixed orifice (0.3 pie) which could be clogged with dusts and other substances and lead to malfunction of the positioner. First of all, remove the pilot valve from the positioner and see if the holes on the screens are not clogged. If the screens are clean and the positioner is not functioning, remove the Auto-Manual switch and check the back of the switch and see if the orifice is clean. Clean the orifice with air and reassemble the switch and the pilot valve to the positioner and test once again. If the unit is still not working, use a 0.2 pie drill or pin and insert into the orifice hole at the back of the Auto-Manual switch.



Fig. 8-1: Pilot unit and Auto manual switch

7.2 Seals

Once a year, it is recommend to check if there are any damaged parts of the positioner. If there are damaged rubber parts such as diaphragms, o-rings and, packings, replace with new ones.

8 Troubleshooting

➤ **Positioner does not respond to the input signal.**

- 1) Check supply pressure level. The lever must be at least 1.4 kgf/cm². For spring-return type of actuator, the supply pressure level has to be larger than the spring's specification.
- 2) Check if input signal pressure is properly supplied to the positioner. The signal pressure should be 0.02 to 0.1 MPa.
- 3) Check if zero point or span point is properly set.
- 4) Check if the positioner's nozzle has been blocked. Also, check if the pressure is supplied to the positioner and pressure is being exhausted through the nozzle. If the nozzle has been blocked by any substances, please send the product for repair.
- 5) Check if feedback lever has been installed properly.

➤ **The pressure of Out1 reaches Supply pressure level and does not come back down.**

- 1) Check auto manual switch. If the switch has been damaged, replace the switch or pilot relay valve.
- 2) Check for a gap or damages between the nozzle and the flapper. If damaged, please send the product to the corresponding local Rotork YTC Limited office or main office in South Korea for repair.

➤ **The pressure is exhausted only by Auto manual switch.**

- 1) Check if the positioner's nozzle has been blocked. Also, check if the pressure is supplied to the positioner and the pressure is being exhausted through the nozzle. If the nozzle has been blocked by any substances, please send the product to the corresponding local Rotork YTC Limited office or main office in South Korea for repair.

➤ **Hunting occurs.**

- 1) Check if stabilizing spring has been displaced. (Next to Pilot unit)
- 2) Check if the size of actuator is too small. If so, insert an orifice in order to reduce the pressure flow rate.
- 3) Check if there is any friction between the valve and the actuator. If so, increase actuator's size or reduce the friction level.

➤ **The actuator moves only to full open and full close positions.**

- 1) Check if Span or Cam of the positioner is installed correctly corresponding to direct or reverse acting of the actuator. If not, refer to 6.1.1 or 6.1.2 section.

➤ **Linearity is too low.**

- 1) Check if linear positioner is properly positioned. Especially check if the feedback lever is parallel to the ground at 50 % point.
- 2) Check if zero and span point have been properly adjusted. If either one of values is being adjusted, another one must be re-adjusted as well.
- 3) Check if supply air pressure level is stable from the regulator. If the level is unstable, the regulator must be replaced.

➤ **Hysteresis is too low.**

- 1) In case of double acting actuator, check if seat adjustment has been properly performed. Please contact YTC for any further inquiries regarding the seat adjustment.
- 2) Backlash can occur when the feedback lever and lever spring are loosen. To avoid backlash, please adjust the lever spring.
- 3) Check if the connection bar to the feedback lever is tightly fastened.

Manufacturer: Rotork YTC Limited

Address: 81, Hwanggeum-ro, 89 Beon-gil, Yangchon-eup, Gimpo-si, Gyeonggi-do, South Korea

Postal code: 10048

Tel: +82-31-986-8545

Fax: +82-70-4170-4927

Email: ytic.sales@rotork.com

Homepage : <http://www.ytc.co.kr>

Issued : 2025-02-19

Copyright © Rotork YTC Limited. All Rights Reserved.