

MOUNTING HOLES CAN BE POSITIONED ON CTRS BY REMOVING 8 BOLTS INDICATED AND REPOSITIONING

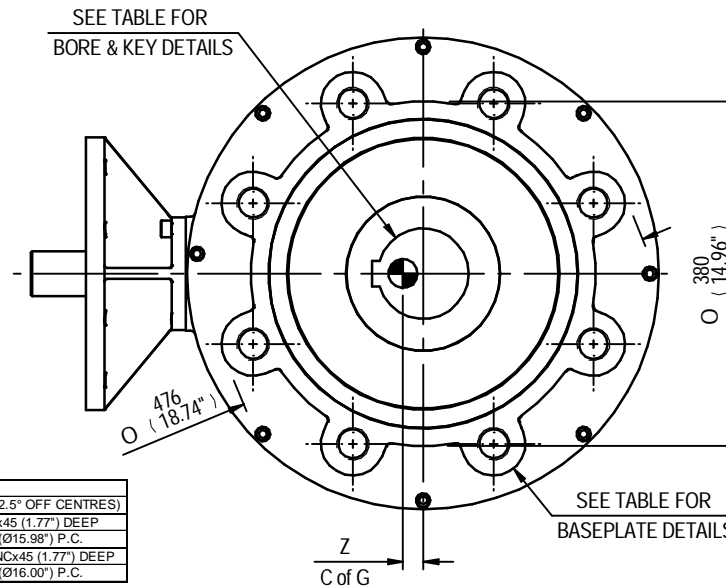
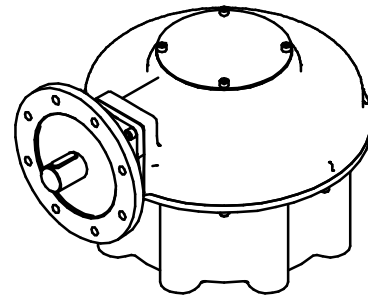
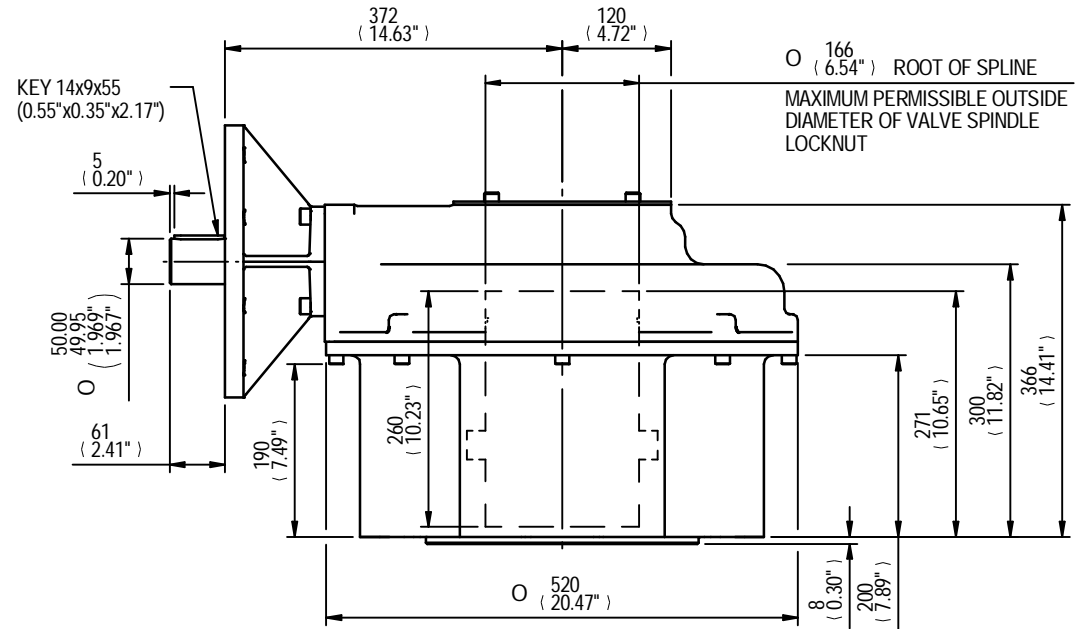
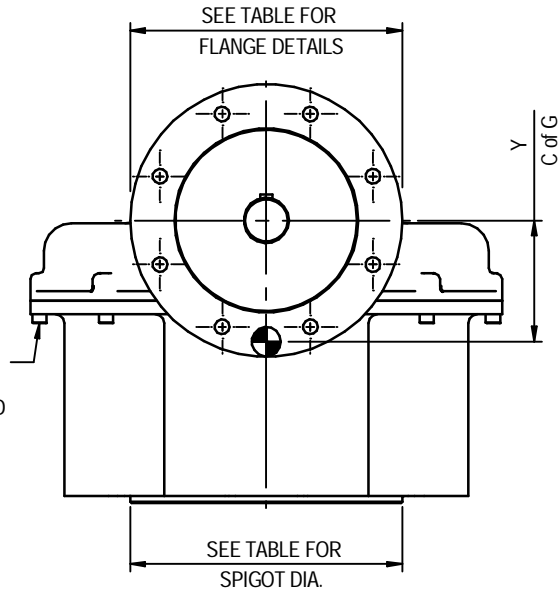

IB RATIO	M.A.	C.O.G.			MAX OUTPUT TORQUE Nm (lbs.ft)
		X	Y	Z	
6	5.10	0	134	22	8135 (6000)
8	6.80	0	124	22	8135 (6000)

MAX BORE SQ KEY			MAX BORE RECTANGULAR KEY			MAX STEM SCREW ACCEPTANCE DIA
STD	BORE	KEY	STD	BORE	KEY	
BS4235	-	-	BS4235	130.0	32 x 18	150 (5.875")
BS46	4.625"	1 1/4" SQ	BS46	5.000"	1 1/2" x 7/8"	
ANSI B17.1	4.625"	1 1/4" SQ	ANSI B17.1	5.000"	1 1/2" x 7/8"	

ISO F25	INPUT FLANGE DETAILS					
	FLANGE O/DIA. & THICKNESS	SHAFT DIA.	RECESS DIA.	RECESS DEPTH	HOLE DETAILS 22.5°(OFF CENTRES)	KEY DETAILS
	Ø300 x 20 (Ø11.81" x 0.79")	Ø50.00-0.05 (Ø1.969"-0.002")	Ø200.10+0.10 (Ø7.878"+0.004")	5 (0.20")	8 HOLES Ø16.5 (Ø0.65") ON Ø254.0 (Ø10.00") P.C.	14x9x55 (0.55"x0.35"x2.17")

ISO F40	BASEPLATE DETAILS	
	SPIGOT DIA.	HOLE DETAILS (22.5° OFF CENTRES)
	Ø299.95-0.05 (Ø11.809"-0.002")	8 HOLES M36x45 (1.77") DEEP ON Ø406.0 (Ø15.98") P.C.

**rotork
gears**

IB14 GEARBOX
F25/FA25 INPUT F40/FA40 OUTPUT

DETAILS SUBJECT TO CHANGE WITHOUT PRIOR NOTICE

FOR UP TO DATE DETAILS VISIT www.rotork.com

APPROX WEIGHT 303.9 kg

DRAWING No	PUBIB14-F25-F40	Regina House Ring Road Bramley Leeds LS134ET United Kingdom
ISSUE	A	
DATE	13/05/2011	