

rotork®

Keeping the World Flowing
for Future Generations

R series

RDx-B-xxxDT-10.41 user manual



 **HANBAY INC.**
A rotork® Brand

RDx-B-xxxDT-10.41
(24 VDC; Battery Backup, TTL Control)

Hazardous Location (Only models RDx-B-BxxxDT w/ ex-proof lid engraving)

USER MANUAL

Contents

<u>INTENDED USE</u>	3
<u>MANUFACTURER DETAILS</u>	3
<u>MEANING OF SYMBOLS</u>	3
<u>INSTALLATION</u>	3
Environmental Conditions	3
Mounting	4
Grounding and Securing	4
Wiring	5
<i>Wiring for Explosion Proof Actuators</i>	5
<i>Wiring for Non-Explosion Proof actuators</i>	7
Power Supply and Current Draw	7
Control Signal and Feedback	8
<i>RDx-B-xxxDT and RDx-B-xxxDT5</i>	8
<i>RDx-B-xxxDT24</i>	9
<u>GENERAL SPECIFICATIONS</u>	10
<u>OPERATION</u>	11
DIP Switches	11
Functionality	12
Calibration	14
Manual Override	14
Troubleshooting	14
Battery Fail Safe Function	15
<i>Testing Battery Fail-Safe</i>	15
<u>CERTIFICATIONS</u>	16
Hazardous Location Rating (Ex)	16
Electrical Compliance (EC)	17
Electromagnetic Compatibility (EMC)	17
Dust and Water Ingress Protection (IP)	17
<u>ACTUATOR DIMENSIONS</u>	18
<u>PART NUMBER BREAKDOWN</u>	21
<u>LABEL BREAKDOWN</u>	21

INTENDED USE

Rotork R-Series actuators are intended to be used in combination with any valve to regulate the flow automatically. The output of the actuator is rotary or linear, and is paired with the valve stem to achieve the desired flow control.

MANUFACTURER DETAILS

Rotork manufactures the R-Series actuator at the following facilities:

Hanbay Inc.
135 Brunswick Blvd.
Pointe-Claire, QC H9R5N2 Canada

Fairchild Industrial Products Company
3920 West Point Blvd.
Winston Salem, NC 27103 USA

MEANING OF SYMBOLS



The exclamation point within an equilateral triangle is intended to alert the user to the presence of important operating and maintenance (servicing) instructions in the literature accompanying the product.



The Lightning Flash with arrowhead symbol within an equilateral triangle, is intended to alert the user to the presence of un-insulated "dangerous voltage" within the product enclosure that may be of sufficient magnitude to constitute a risk of shock to persons.

INSTALLATION

The safety of any system incorporating the equipment is the responsibility of the assembler of the system.

Environmental Conditions

The R-Series actuator has an IP68 rating and is recommended for outdoor use. The relative humidity of the environment has no effect on the R-Series.

The ambient temperature range for the standard R-Series is -20 to 40 °C (-4 to 104 °F).
The internal heater option shifts the temperatures to a lower range of -40 to 40 °C (-40 to 104 °F).

The standard R-Series has been approved for use at altitudes of up to 2000 m.



Mounting

The holes indicated in the image are intended for a mounting bracket. They are threaded for 1/4-20 and are 0.4" deep.

Grounding and Securing

The other two visible holes are threaded 10-32, 0.50" deep, and are intended to be used to lock the lid in position (top) and as an external grounding connection (bottom) using user-supplied screws.

For detailed dimensions see p.16.

Additionally, there is a grounding connection supplied internally.

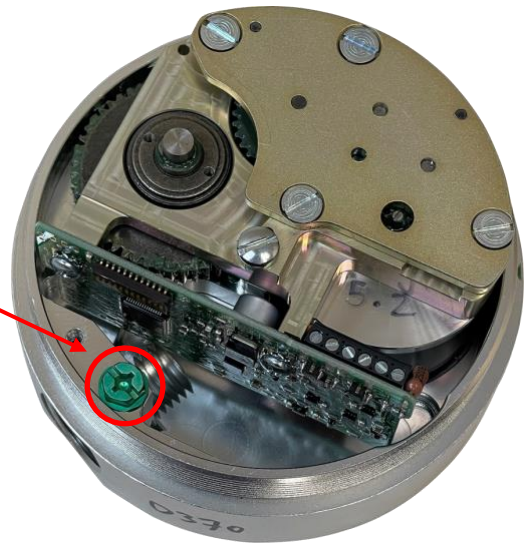

Wiring

Wiring for Explosion Proof Actuators



The **RDx-BxxDT** Explosion-Proof actuator does **not** come with a pre-installed cable, nor cable gland. A cable gland that meets site specifications for the appropriate hazardous location rating is required for installation. The cable gland and the cable for hazardous location should be installed by qualified personnel in accordance with site and local requirements.

The actuator comes standard with a 1/2" FNPT thread cable entry. See p.16 for location of 1/2" FNPT housing access. A cable with 6 wires is required; it is recommended to use 16-24 AWG for all wires.



Standards for cable gland and cable in hazardous locations:

Compliance Standards Required to be Met	Cable Types Permitted in Class I Division 1 Hazardous Locations
ANSI / UL 514B, ANSI / UL 1203, ANSI / UL 2225, C22.2	Non-Armored Extra Hard Usage Cord & TC-ER-HL
ANSI / UL 514B, ANSI / UL 1203, ANSI / UL 2225	Armored IEEE 45 & IEEE 1580 Marine Shipboard Cable
ANSI / UL 514B, ANSI / UL 1203, ANSI / UL 2225	MC-HI, ITC-HL
ANSI / UL 514B, ANSI / UL 1203, C22.2	Teck 90 (Canada Only)

* In explosion-proof models, the FNPT thread is not intended for conduit connection. Cable gland only.

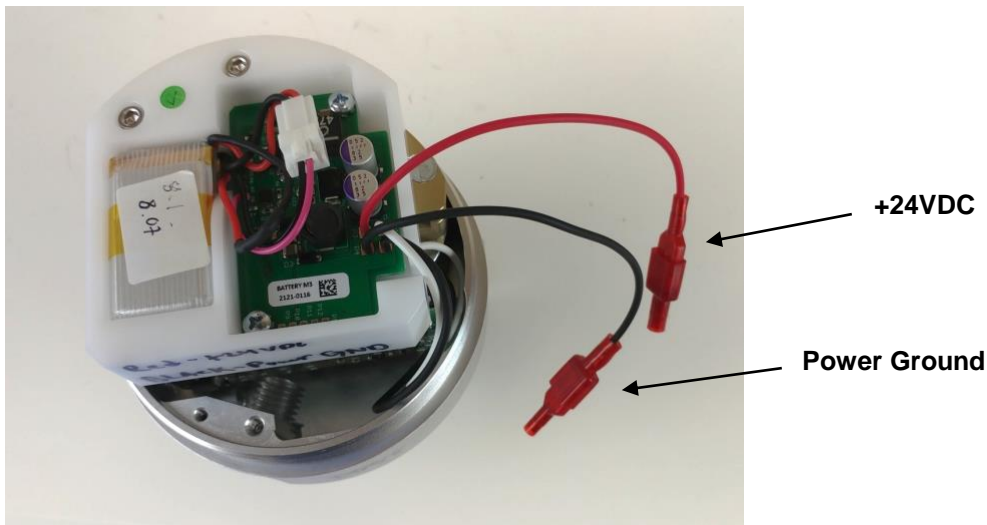

Note: Power ground must be externally connected to earth ground, or one of the case grounding screws (see Grounding and Securing section) must be used to connect a grounding wire of minimum 22AWG.

The battery board holder (white plastic part, see image below) will have to be unscrewed to access the terminal block on the circuit board for wiring. When wiring is complete screw the battery board holder back into place.



Do not remove or change the existing **BLACK** and **WHITE** wires that connect the battery board to the processor board.

Once the cable and cable gland are installed, connect the wires to the pins on the terminal block as indicated here:

Pin	Function
6	Already Connected to battery board Connect +24 VDC wire to loose red cable with crimp connector (see above)
5	Already Connected to battery board Connect power ground wire to loose black cable with crimp connector (see above)
4	Output TTL2
3	Output TTL1
2	Input TTL2
1	Input TTL1

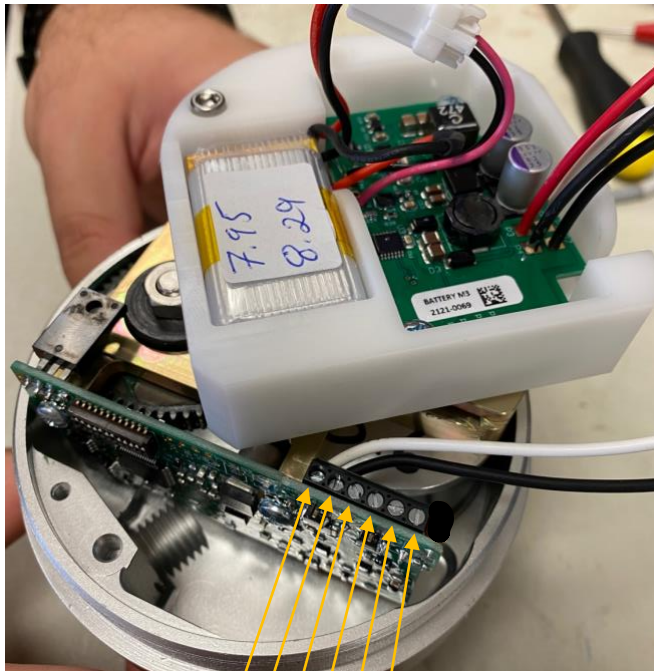

6 5 4 3 2 1
Terminal

Wiring for Non-Explosion Proof actuators

The actuator comes standard with a Turck 6 position connector and a 20' cable with plug. Cut the cable to the length required and then connect according to the following wire color schematic:

Wire color schematic for “Turck 6” cable:

Pin	Color	DC power supply only
6	White	+24 VDC
5	Black	Power gnd.
4	Pink	Output TTL2
3	Grey	Output TTL1
2	Blue	Input TTL2
1	Brown	Input TTL1



Note: Power ground must be externally connected to earth ground, or one of the case grounding screws (see Grounding and Securing section) must be used to connect a grounding wire of minimum 22AWG.

Power Supply and Current Draw

The **RCx-B-xxxAx** can **ONLY** be connected to 24 VDC +/- 10%. The DC supply to the actuator must be limited by a 4 A fuse or circuit breaker; it is recommended to have this installed near the actuator.

The current draw will range from minimum 100 mA to maximum 3 A while the actuator is active. When not moving, the actuator draws approx. 50 mA.

Control Signal and Feedback

RDx-B-xxxDT and RDx-B-xxxDT5

Actuators with part numbers RDx-B-xxxDT and RDx-B- have the old standard 5 V TTL control and feedback signals. Locate the correct connection terminals/wires (as shown on the previous page), then set-up the PLC as shown below.

- Connect your input signal on positions 1 and 2 (brown and blue wires)
The input signals are high by default (+5 V). To change the value, send a low signal (0 V ↔ pull to ground).
 See the Functionality section for details.
- Feedback is connected to positions 3 and 4 (grey and pink wires)
 The maximum drive current is 2.5 mA.

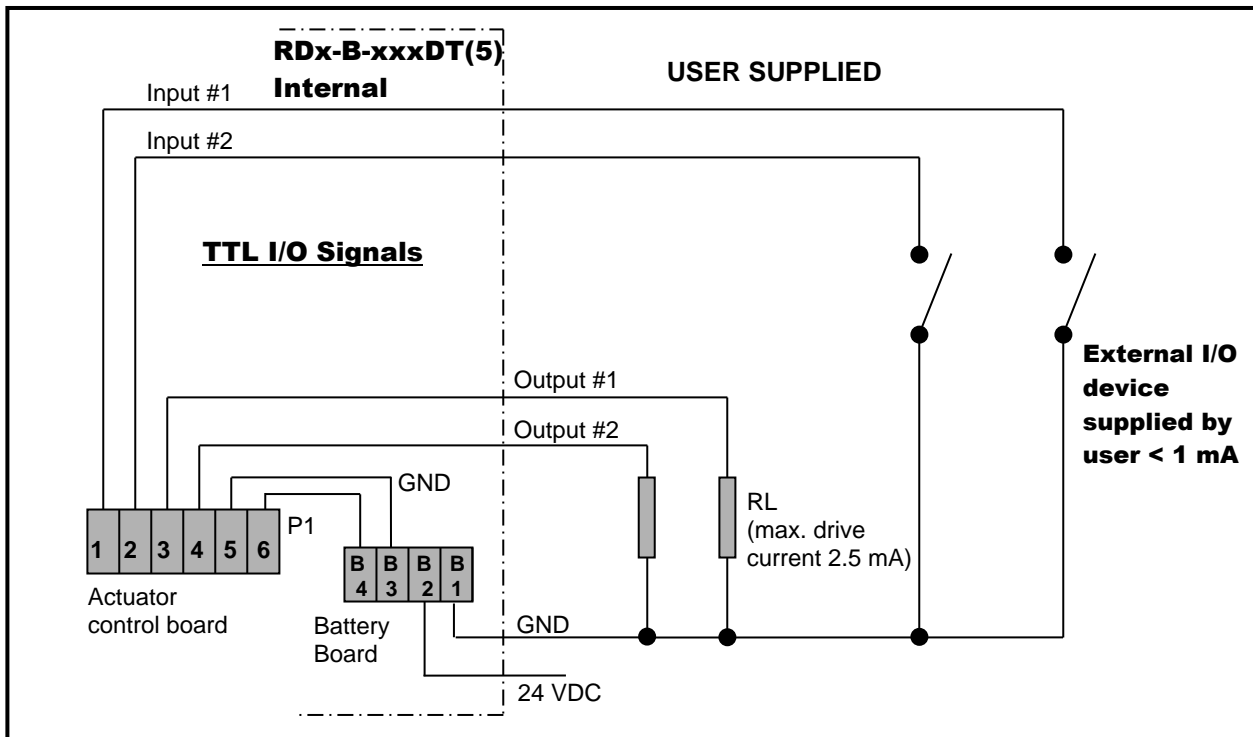

RDx-B-xxxDT24

Actuators with part numbers RDx-B-xxxDT24 have the new standard 24 V TTL control and feedback signals. Locate the correct connection terminals/wires (as shown on the previous page), then set-up the PLC as shown below.

- Connect your input signal on positions 1 and 2 (brown and blue wires)
The input signals are high by default (24 V). To change the value, send a low signal (0 V ↔ pull to ground).
 See the Functionality section for details.
- Feedback is connected to positions 3 and 4 (grey and pink wires)
 The maximum drive current is 0.5 A.

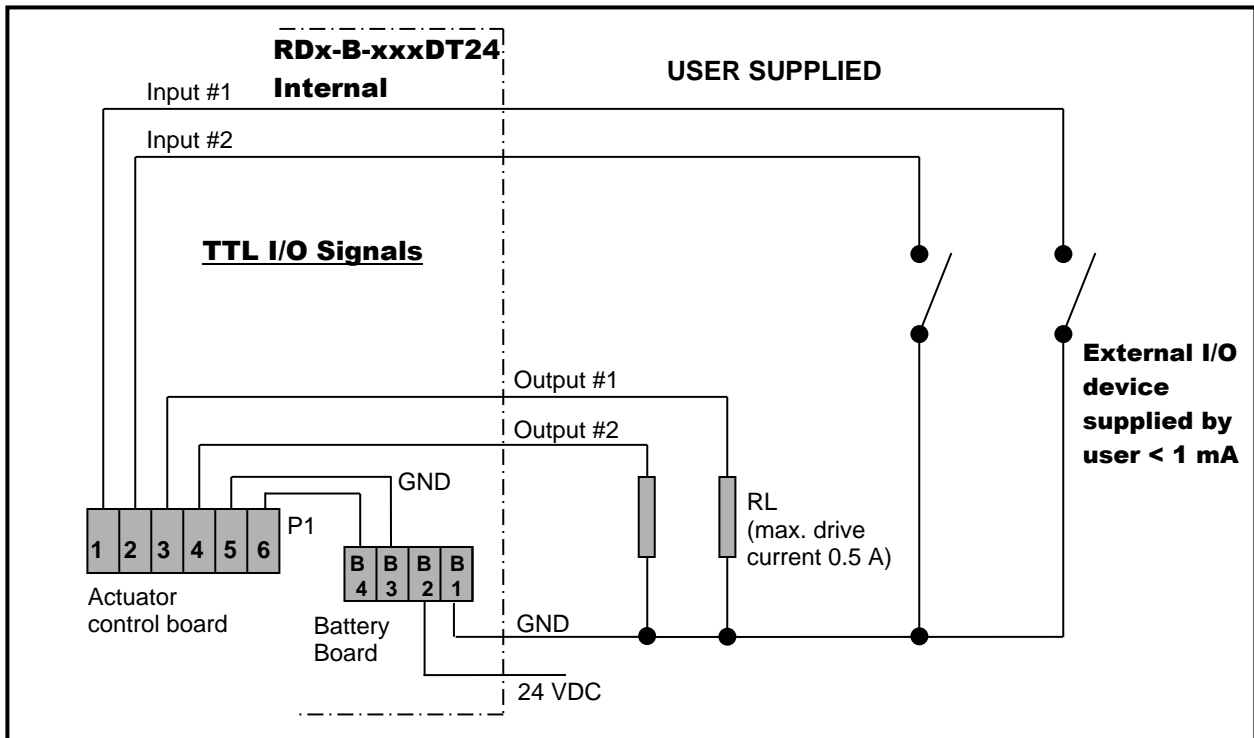

GENERAL SPECIFICATIONS

Stall protection	Electronic position and motion detection
Gears & Bearings	Metal and bronze, oiled/greased for life
External fasteners	Stainless Steel
Life Expectance	250'000 cycles in specified conditions
Motor	Brushless DC motor, computer control
Positioning precision	$\pm 3^\circ$
Positioning resolution	$\pm 0.15^\circ$ max.
Power setting	Adjustable
Mechanical Shock	Repeated ≤ 130 g-force, no effect Occasional ≤ 150 g-force, no effect >150 g-force not tolerated
Mechanical Vibration	Random SAE J1211, Chassis, Exterior
Thermal Shock	-20 to +60 °C (-4 to 140 °F) in 10 min.
Weight	RxJ, RxL, RxM: 980 g RxH, RxF: 1700 g
TTL Signals in	Internal pull up < 1 mA required to pull down
TTL signals out (feedback)	Standard: 5 V at 2.5 mA max. Option: 24 V at 1 A max.

OPERATION

DIP Switches

The DIP switches allow you to change the settings on your actuator. To flip a switch, gently use a small flat-head screwdriver.

See the table below for DIP switch functionality.

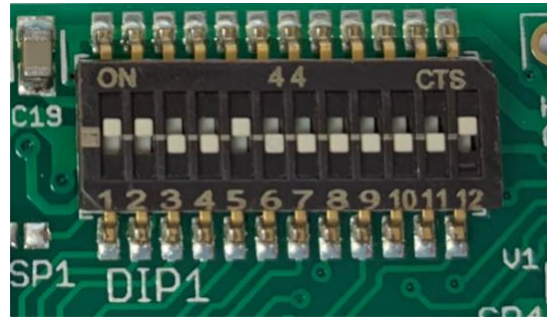

In this example DIPs 1, 2, 5 and 12 are on.

DIP 1	DIP 2	Description	Recommended Use
Off	Off	Fastest settling	Use only for low torque valves
Off	On	Medium-fast	Typical setting
On	Off	Medium-slow	Typical setting
On	On	Slowest settling	Use for high torque valves

DIP switches 1 and 2 set the actuator position control parameters. High settling speed settings are suitable for fast positioning of light valves. Longer settling times will allow heavier valves to reach their target positions; trying to use a fast settling setting on a high torque valve will increase current consumption when holding position, and cause heating of the motor.

DIP 10	DIP 11	Torque description	Approximate stall current (A)	Approximate stall torque (in-lbs)			
				RDL	RDM	RDH	RDF
Off	Off	Low	1.0	63	212	430	715
Off	On	Medium-low	1.5	72	236	522	832
On	Off	Medium-high	2.0	77	243	525	949
On	On	High	3.0	83	247	532	1067

DIP switches 10 and 11 set the actuator torque. These settings are adapted to the valve at the factory. Worn-in valves may require a higher torque setting after some time. The actuator will use 100% of available torque to try and reach maximum speed.



- Note:** Medium-high and high settings require voltage supply minimum values as follows:
- Supply voltage needs to be min 14 VDC for medium-high
 - Supply voltage needs to be 16 VDC for high
 - When operating above 20 VDC and 66% power, Duty cycle is reduced to 50% - 25% maximum. At these levels, the electronics produce more heat which must be dissipated (depending on environmental temperature)

DIP 3	Reserved for custom function.
DIP 4	Sets direction of offset (offset only required in RDH and RDF models).
DIP 5	Sets the highest amount of offset, typically 12°. NOTE: To set maximum offset DIPs 5,6, and 7 will need to be high for a total of 21°. The maximum offset can also be set differently at the factory (upon customer request).
DIP 6	Sets medium offset, typically 6°.
DIP 7	Sets the lowest amount of offset, typically 3°.
DIP 8	With DIP 8 in the ON position, the actuator will move to 4 positions. When DIP 8 is in the OFF position, the actuator is limited to three positions. DIP 8 also changes the function of the output signals. See p.12 for details.
DIP 9	Run / Calibrate Putting DIP 9 into the off position will disable the actuator positioning control, and the motor will not move regardless of the input signals. When DIP 9 is moved back into the on position, the actuator will perform its homing routine, and then move to the position commanded by the input signals.
DIP 12	DIP 12 sets the direction of rotation

Functionality

The RDx-B-xxxDT can operate as a 3-position or 4-position actuator. The 4th position is enabled by turning DIP 8 ON.

Direction of rotation and using input 1

To change the direction of rotation on the actuator change the setting on DIP 12 and cycle power to the actuator.



VERY IMPORTANT: Input 1 must always be used if only one input is used to operate the valve. When the actuator is operated using input 1 an automatic calibration is done every time the valve is actuated. This does not happen on input 2.

Inputs 1 & 2 (pins 1 & 2) are HIGH by default – a LOW signal must be sent to change the value.

Low ≤ 0.8 VDC for all models
High ≥ 4.5 VDC for RDx-B-xxxDT and RDx-B-xxxDT5
 ≥ 20 VDC for RDx-B-xxxDT24



Sending a signal of more than 24 VDC may be harmful to the internal circuit board.

3-pos Functionality (DIP 8 OFF)

Input #1 (Pin 1)	Input #2 (Pin 2)	Action taken
High	High	Moves to or remains in centre position
Low	High	Moves to or remains in right position
High	Low	Moves to or remains in left position
Low	Low	Moves to or remains in left position (Input #2 has precedence over Input #1)
The feedback is as follows:		
Output #1 (Pin 3)	Output #2 (Pin 4)	Meaning
High	High	Valve is in centre position
High	Low	Valve is in right position
Low	High	Valve is in left position
Low	Low	Actuator is moving or has stalled and given up trying to reach a requested position. You may retry to reach any position by cycling both inputs one after the other. Repeated failures to reach position will require troubleshooting.

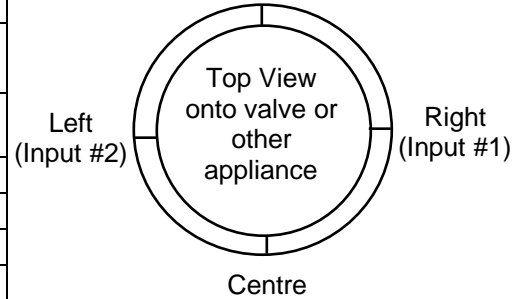

4-pos Functionality (DIP 8 ON)

Input #1 (Pin 1)	Input #2 (Pin 2)	Action taken
High	High	Moves to or remains in centre position
Low	High	Moves to or remains in right position
High	Low	Moves to or remains in left position
Low	Low	Moves to or remains in back position
The feedback is as follows:		
Output #1 (Pin 3)	Output #2 (Pin 4)	Meaning
Low	Low	Actuator is at requested position
High	Low	Actuator is moving
Low	High	Actuator has stalled. The stall can be cleared by making the actuator turn in the other direction. Repeated failures will require troubleshooting.

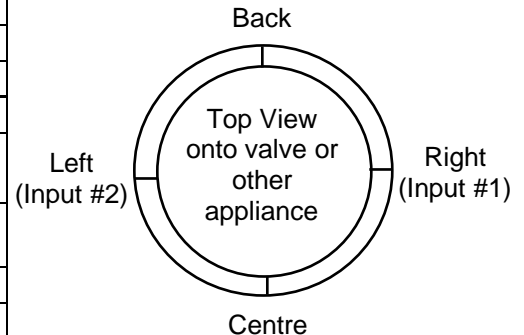

Calibration

The center position calibration routine can be initiated by switching DIP 9 momentarily “off” then “on”. This will cause the actuator to go through a series of movements to determine the proper center position. This function is useful if the actuator’s output gear gets manually rotated while the actuator is powered down and can’t properly realign to the center by itself.

Manual Override

The RDx actuator with manual override can also be certified for hazardous locations. The additional manual override gear case and handle has no effective ignition sources and can therefore be used in all hazardous locations for which the actuator enclosure is certified for.

Operation of the manual override when power is applied will be difficult as the actuator will try to maintain the valve in the position it has been commanded to.



Power should be removed if the valve is to be moved manually. If the valve is moved with the manual override when its power is turned off, it will lose its position, and it will need to be re-zeroed (as described in the Calibration section).

Troubleshooting

Upon noticing a problem, your first step should almost always be to recalibrate the actuator by toggling DIP 9 while the actuator is powered. This alone can solve basic problems.

If the actuator does not move, try following these steps:

- 1) Re-calibrate the actuator. This will move the actuator regardless of what signal it is receiving.
- 2) A sticking valve may be the problem. Remove the valve from the actuator, and re-test the actuator.
- 3) Remove power. Re-check the wiring and the power/signal apparatus. Power actuator, and re-calibrate. If the problem persists, please call Rotork for technical support.

Any parts found to be defective should be examined and/or replaced by Rotork.

Battery Fail Safe Function

1. In the event of a loss of power or signal, the battery will maintain power to the P1 processor and trigger the actuator to move the valve to its designated fail-safe position, using power from the battery.
2. Once the valve has reached its fail-safe position, and after about one minute, the P1 processor will go into sleep mode to preserve the battery life.
3. The actuator will not respond to commands until the power supply is restored.

Note: The battery will maintain a charge for up to 2 months without power being applied. The fail-safe actuation can be performed for 30 cycles on the charge available in the battery. During normal operation, from totally discharged, the batteries will take 2 hours to re-charge.



If in a critical fail-safe application, the battery function should be tested monthly.

Testing Battery Fail-Safe

- The batteries will be continuously on charge when power is available to the actuator.
- Regardless of application, the fail-safe function should be tested monthly by signaling the unit to the position opposite the fail position, removing the power to the actuator and observing whether the actuator reaches the desired fail position.
- The battery voltage can be measured with a multimeter set for DC volt measurement.

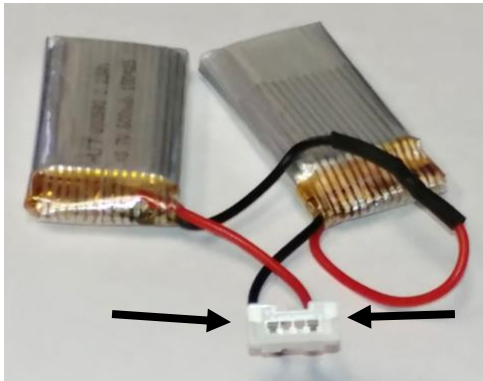

Measure battery voltage between the connector terminals. Value should be: 7.9 ± 0.4 VDC



CERTIFICATIONS

Hazardous Location Rating (Ex)

Actuator model number: RCx-**B**xxAx

Canada:

Class I, Division 1, Groups B, C, D (T5)
 Class II, Division 1, Groups E, F, G (T5)

CSA C22.2 No. 30-M1986
 CSA C22.2 No. 25-17

Ambient temperature range: -50°C to +40°C

* Serial number will be engraved on lid.
Lid engraving with Canadian hazardous location certification:



USA:

Class I, Division 1, Groups B, C, D (T5)
 Class II, Division 1, Groups E, F, G (T5)

UL 1203 (Edition 5.0)

Ambient temperature range: -20°C to +40°C

* Serial number will be engraved on lid.
Lid engraving with USA hazardous location certification:



International (IECEEx) – available upon request:

Ex db IIB+H2 T3 Gb

IEC 60079-0:2017, 7th Edition
 IEC 60079-1:2014, 7th Edition

*Serial number will be engraved on the lid.

Electrical Compliance (EC)

Canada & USA:

CSA.UL 61010-1

Europe:

EC Declaration of Conformity (CE)

UK Declaration of Conformity (UKCA)

Electromagnetic Compatibility (EMC)

United States:

FCC 47 CFR Part 15, Subpart B (Unintentional radiators), Class A

Canada:

ICES-001 Issue 5, July 2020, Class A

Europe:

EN 61326-1:2013 (Group 1, Class A; Industrial electromagnetic environment)

IEC 61000-6-2:2016

IEC 61000-6-4:2018

Dust and Water Ingress Protection (IP)

IP68, certified using standard IEC 60529:2013.

ACTUATOR DIMENSIONS

RDL & RDM -B-xxxDT models

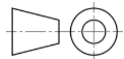
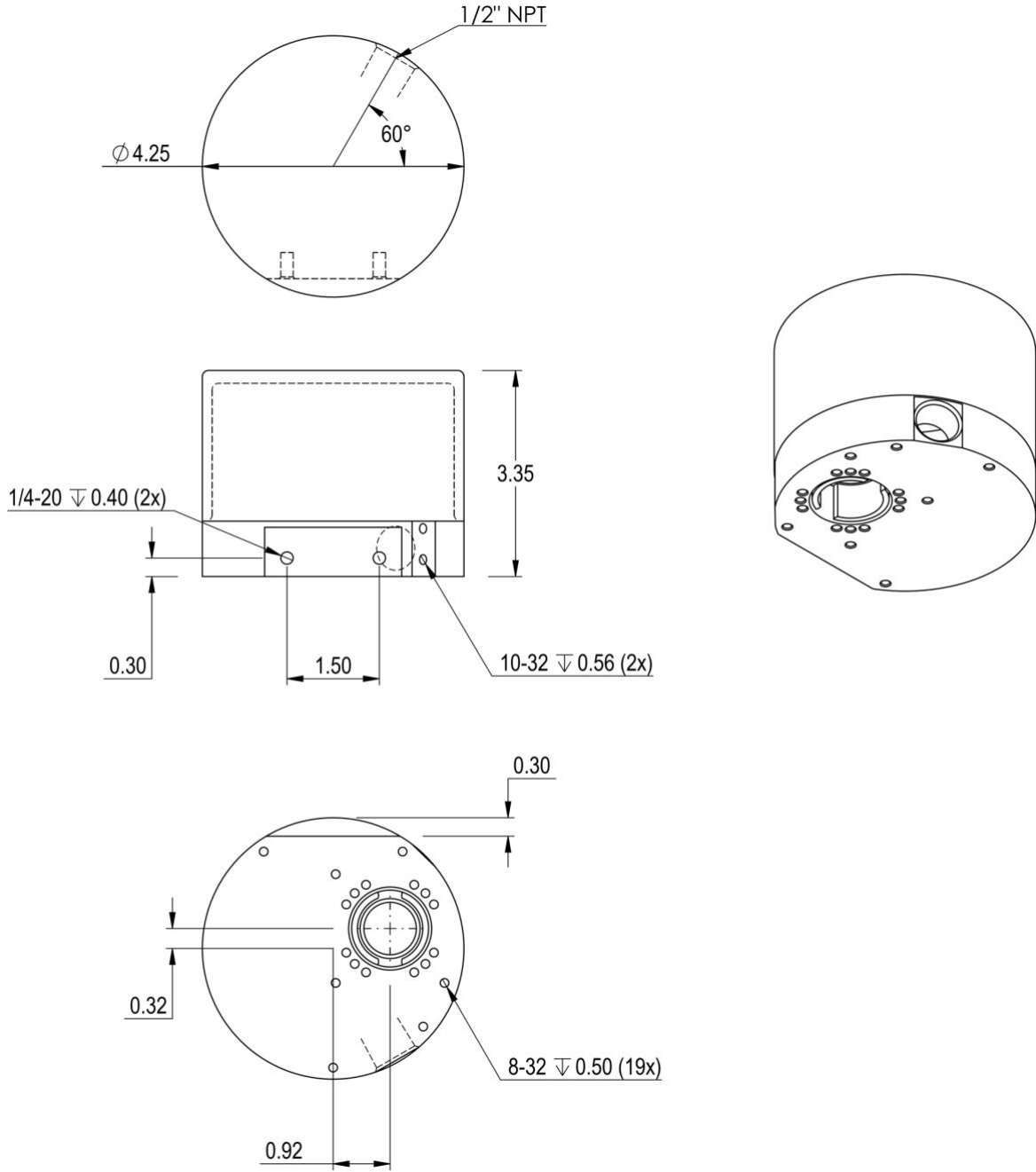

RDH-B-xxxDT models

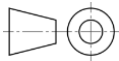
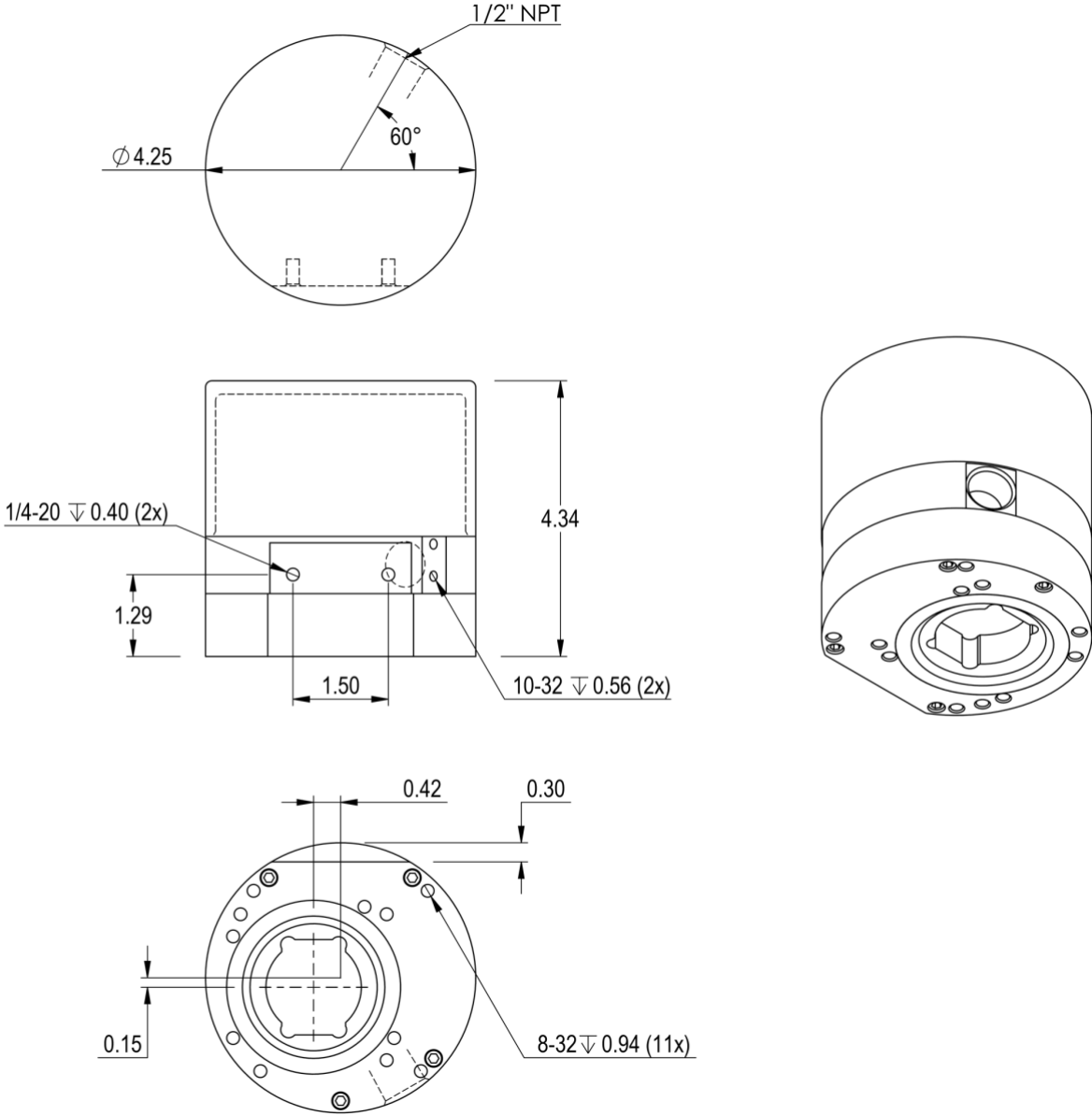

RDF-B-xxxDT models

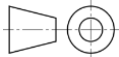
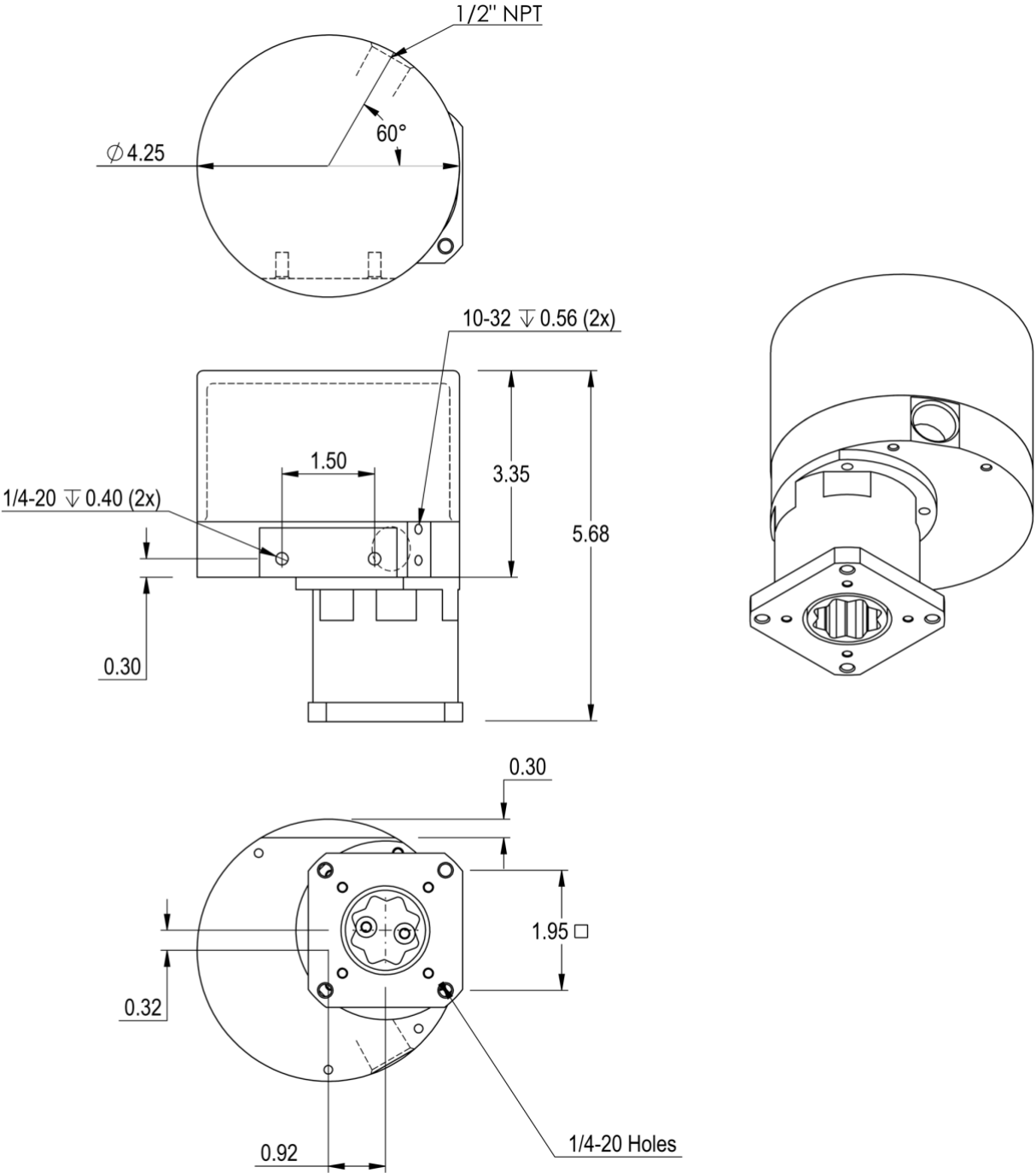

PART NUMBER BREAKDOWN

Full Part Number:

R	D		-	B					DT								
---	---	--	---	---	--	--	--	--	----	--	--	--	--	--	--	--	--

	Base Enclosure	Positioning	Gear Train	Special Options	Enclosure Options	Wiring	Thermal Management	PCB	Mounting Kit	Valve Part Number	
R			-						-	-	Valve Manufacturers Part # / CU #
R	R-Series										0 No Valve or Mounting Kit 1 Mounting Kit, Customer Supplies Valve, does not send valve to Hanbay 2 Mounting Kit, Customer Supplies Valve, sends valve to Hanbay 3 Mounting Kit, Hanbay Provides Valve
C	Continuous										
D	Discrete										
J	Extra Low Torque										
L	Low Torque										
M	Medium Torque										
H	High Torque (Add. Gear Stage)										
F	F-Gear Stage (Add. Gear Stage)										
											AB Analog Signal Board AF Analog Signal Board Isolated with Feedback AI Analog Signal Board Isolated Input AS Modbus Control with Feedback DC24 Continuous TTL Board, 0V input / 24V feedback signal DC5 Continuous TTL Board, 0V Input / 5V feedback signal DT24 Discrete TTL Board, 0V Input / 24V feedback signal DT5 Discrete TTL Board, 0V Input / 5V feedback signal PT Propane Board, Limit Switches, Thermal Cut Off
											0 No Option H Internal Heater
											0 Cable Gland (Specify Cable & length at added cost) *If the actuator has an ex-proof enclosure, 0 indicates an NPT plug 4 Custom Dual Gauge Cable, 10ft. 5 TURCK 5 Position Connector w. 20' Cable and Plug 6 TURCK 6 Position Connector w. 20' Cable and Plug 7 TURCK 5 Position Connector Only 9 TURCK 6 Position Connector Only
											0 Standard Anodised Alloy Enclosure B Hazardous Locations-Rated S Stainless Steel Enclosure E Stainless Steel Hazardous Locations-Rated
											0 No Special Options AC 110-240 VAC Power Supply B Battery Backup BS Bottom Stop G G-Stage Gate Valve (with MCM or MCL) HT High Temperature Mounting Kit L1 Linear 16 TPI L2 Linear 8 TPI M Manual Override PM Position Indicator (Multi-turn) QR Quick Release Mounting Kit RS Reverse Spring Return S Spring Return

LABEL BREAKDOWN

Firmware Version

- AF-1.05
 - AB-1.05
 - AS-1.05
 - DT-2.01
 - DC-2.01
 - M-Dx V2.34
- MM = Multiturn
MML = Multiturn Low Torque
MMUL = Multiturn Extra Low Torque
QM = Quarter turn
QM97 = Quarter turn 97°

Actuator Supply Voltage

12-24 VDC @ 3.0 A or
110-240 VAC, 50/60 Hz @ 1.5 A

Actuator Series

M-Series or R-Series

Circuit Board Version

- Ax-8.09
- Dx-10.41
- Px-10.3



www.hanbayinc.com
(336) 659 3400
NC, 27103



R-Series 12-24 VDC 3.0A

RCM-050AB

POWER OFF UNIT BEFORE REMOVING COVER

Made in USA

S/N: 19103201-01

Ax-8.09
AB-1.05MM

User Manual:



Actuator Part Number

Refer to part number breakdown for available options.

QR Code

Scan this QR code for a direct link to the user manual for your unit!

Actuator Serial Number

This serial number is unique for each individual unit and is directly tied to your order/invoice number.

As part of a process of on-going product development, Rotork reserves the right to amend and change specifications without prior notice. Published data may be subject to change. For the very latest version release, visit our website at www.rotork.com
The name Rotork is a registered trademark. Rotork recognises all registered trademarks. Published and produced in the UK by Rotork. POLJB0424