

rotork®

Keeping the World Flowing
for Future Generations

M series

MDx-AC-xxxDT-10.41 user manual

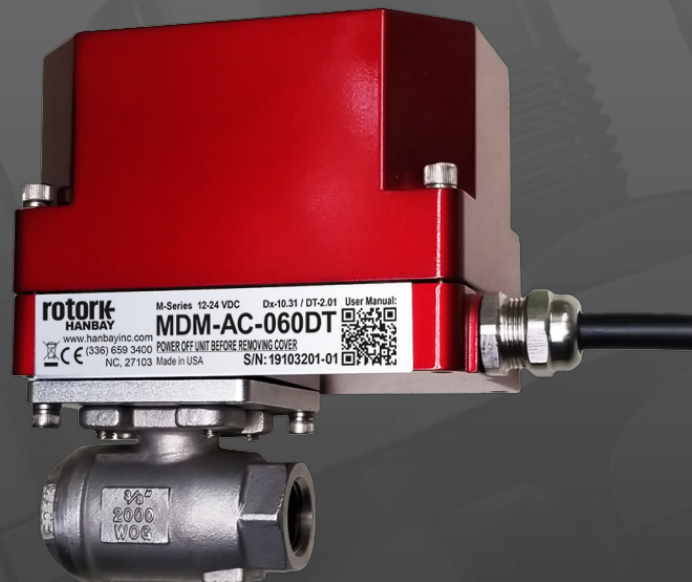

 **HANBAY INC.**
A rotork® Brand

MDx-AC-xxxDT-10.41
(120-240 VAC; TTL Control)

USER MANUAL

Contents

<u>MEANING OF SYMBOLS</u>	3
<u>INSTALLATION</u>	3
Environmental Conditions	3
Mounting	3
Wiring	4
Power Supply and Current Draw	5
Control Signal and Feedback	6
<i>MDx-AC-xxxDT and MDx-AC-xxxDT5</i>	6
<i>MDx-AC-xxxDT24</i>	7
<u>OPERATION</u>	8
DIP Switches	8
Functionality	9
Calibration	11
Troubleshooting	11
<u>ACTUATOR DIMENSIONS</u>	12
<u>PART NUMBER BREAKDOWN</u>	15
<u>LABEL BREAKDOWN</u>	16

MEANING OF SYMBOLS



The exclamation point within an equilateral triangle is intended to alert the user to the presence of important operating and maintenance (servicing) instructions in the literature accompanying the product.



The Lightning Flash with arrowhead symbol within an equilateral triangle, is intended to alert the user to the presence of un-insulated "dangerous voltage" within the product enclosure that may be of sufficient magnitude to constitute a risk of shock to persons.

INSTALLATION

The safety of any system incorporating the equipment is the responsibility of the assembler of the system.

Environmental Conditions

The M-Series actuator has an IP66 rating but is recommended for indoor use in environments with a relative humidity below 80%. For outdoor use, or for use in higher humidity environments, please consider the equivalent R-Series actuator with its IP68 rating.

The ambient temperature range for the standard M-Series is -20 to 40 °C (-4 to 104 °F).
The internal heater option shifts the temperatures to a lower range of -40 to 40 °C (-40 to 104 °F).

The standard M-Series has been approved for use at altitudes of up to 2000 m.

Mounting

In most cases, the actuator must be mounted and supported as shown in the image to the right. The mounting bracket is not supplied by Rotork.

Exceptionally, the actuator may be suspended on the tubing itself but ONLY if the application is vibration free and the tubing is minimum ¼" dia. stainless.

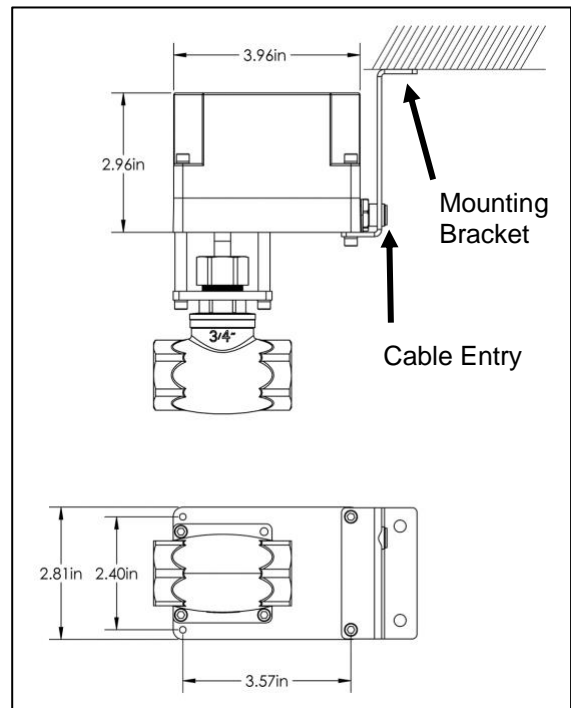

Wiring

The actuator comes standard with a pre-installed cable gland and a 10' cable. Cut the cable to the length required, then connect according to the following wire color schematic:

Wire colour schematic for cable:

Colour	Function
Black (1)	Live 110-240 VAC (18 AWG)
Red (2)	Neutral 110-240 VAC (18 AWG)
Green (3)	Ground \perp (18 AWG)
Yellow (4)	Output TTL2 (22 AWG)
Grey (5)	Output TTL1 (22 AWG)
Blue (6)	Signal Input TTL 2 (22 AWG)
Brown (7)	Signal Input TTL 1 (22 AWG)

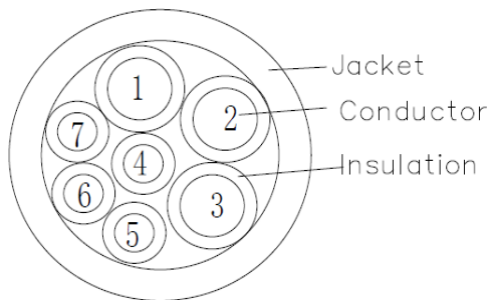

If the cable is not included with your actuator, connect the wires according to the chart below:

Pin	Function
6	Already connected to power supply (connect live wire to loose black cable, see below)
5	Already connected to power supply (connect neutral wire to loose red cable, see below)
4	Output TTL2
3	Output TTL1
2	Input TTL2
1	Input TTL1

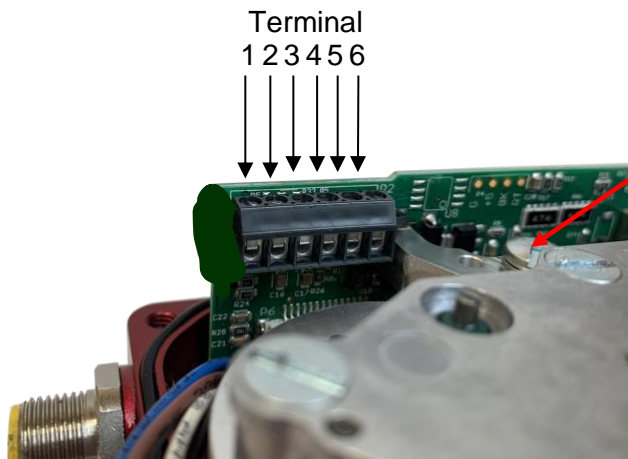

The protective earth wire should be placed underneath the screw indicated here. To do this, loosen the screw, then re-tighten while ensuring the earth wire stays in place.

Power Supply and Current Draw

The **MDx-AC-xxxDT** may be connected to voltages ranging within 120-240 VAC. The AC supply to the actuator must be limited by a 1.5 A fuse or circuit breaker; it is recommended to have this installed near the actuator.

The current draw will range from minimum 10 mA to maximum 1.5 A while the actuator is active. When not moving, the actuator draws approx. 5 mA.



Control Signal and Feedback

MDx-AC-xxxDT and MDx-AC-xxxDT5

Actuators with part numbers MDx-AC-xxxDT and MDx-AC-xxxDT5 have the old standard 5 V TTL control and feedback signals. Locate the correct connection terminals/wires (as shown on the previous page), then set-up the PLC as shown below.

- Connect your input signal on positions 1 and 2 (brown and blue wires)
The input signals are high by default (+5 V). To change the value, send a low signal (0 V ↔ pull to ground).
 See the Functionality section for details
- Feedback is connected to positions 3 and 4 (grey and pink wires)
 The maximum drive current is 2.5 mA.

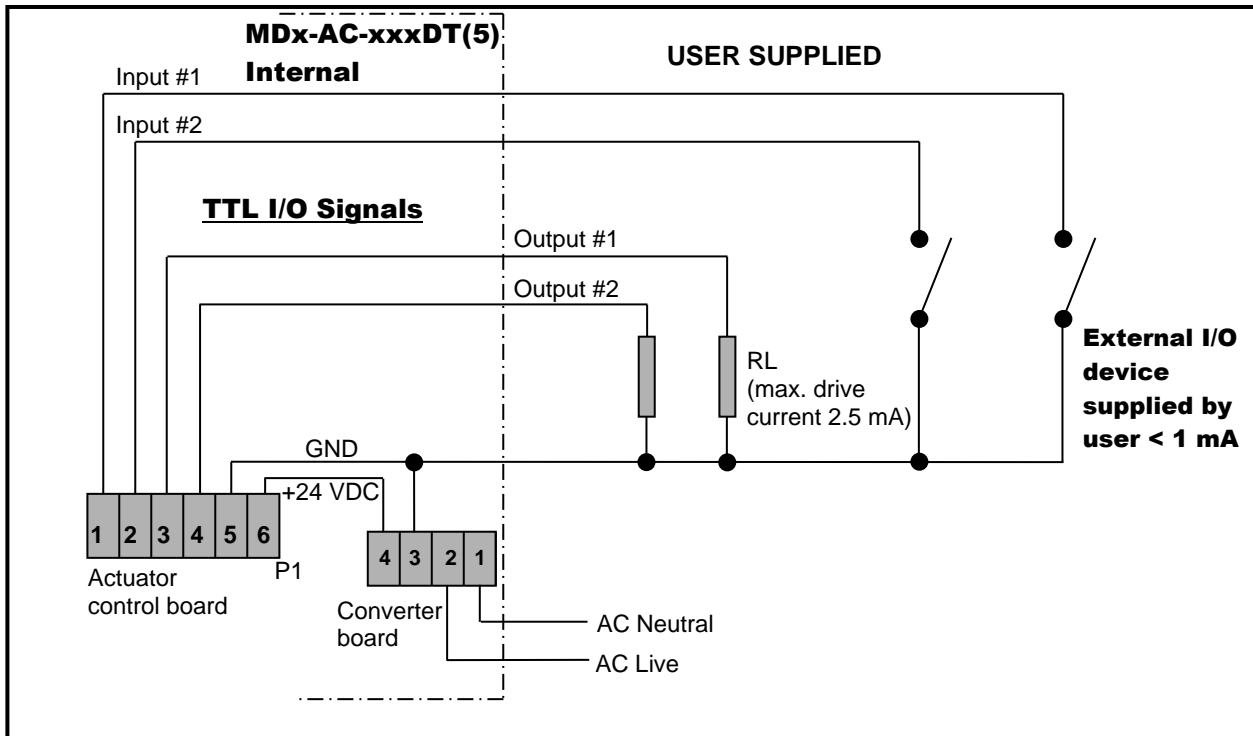

MDx-AC-xxxDT24

Actuators with part numbers MDx-AC-xxxDT24 have the new standard 24 V TTL control and feedback signals. Locate the correct connection terminals/wires (as shown on the previous page), then set-up the PLC as shown below.

- Connect your input signal on positions 1 and 2 (brown and blue wires)
The input signals are high by default (24 V). To change the value, send a low signal (0 V ↔ pull to ground).
 See the Functionality section for details.
- Feedback is connected to positions 3 and 4 (grey and pink wires)
 The maximum drive current is 0.5 A.

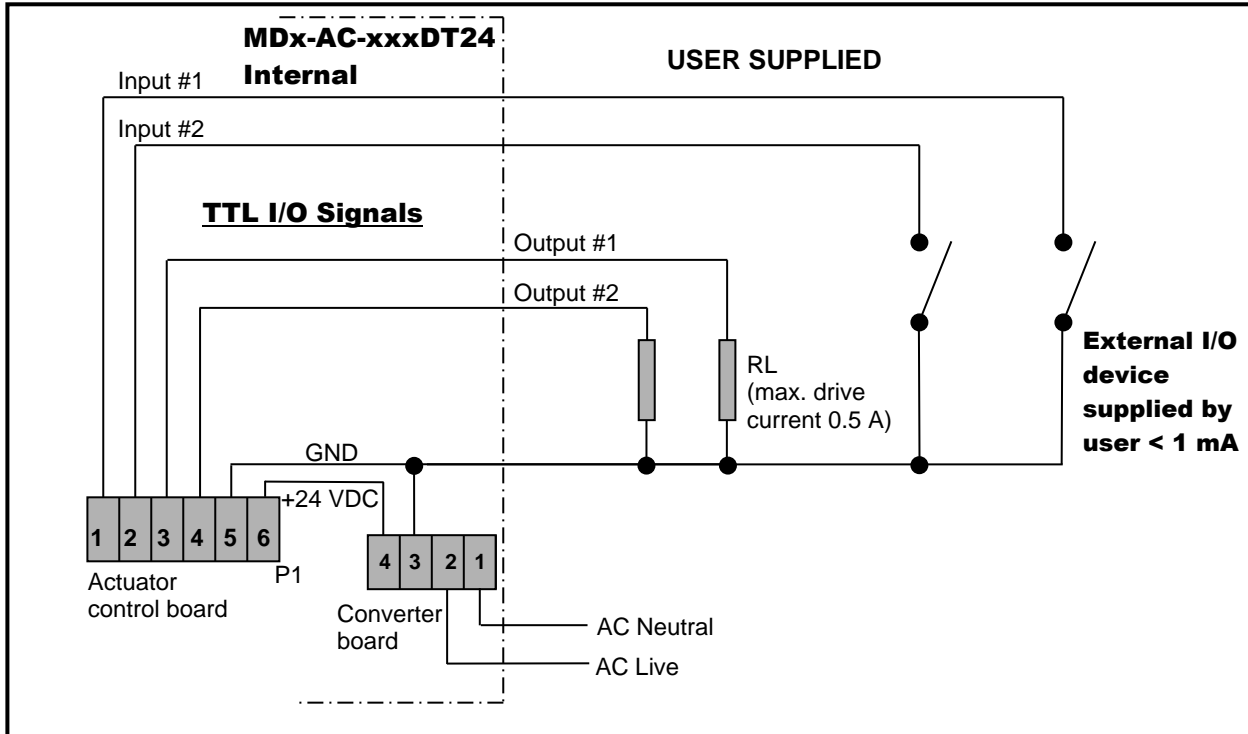

OPERATION

DIP Switches

The DIP switches allow you to change the settings on your actuator. To flip a switch, gently use a small flat-head screwdriver.

See the table below for DIP switch functionality.

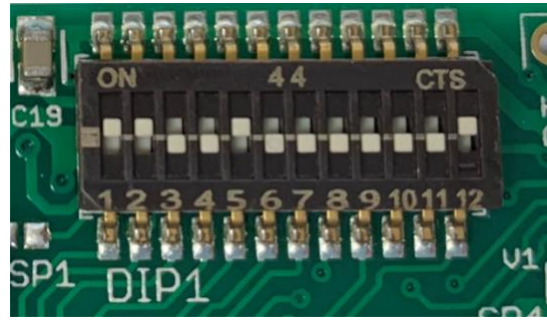

In this example DIPs 1, 2, 5 and 12 are on.

DIP 1	DIP 2	Description	Recommended Use
Off	Off	Fastest settling	Use only for low torque valves
Off	On	Medium-fast	Typical setting
On	Off	Medium-slow	Typical setting
On	On	Slowest settling	Use for high torque valves

DIP switches 1 and 2 set the actuator position control parameters. High settling speed settings are suitable for fast positioning of light valves. Longer settling times will allow heavier valves to reach their target positions; trying to use a fast settling setting on a high torque valve will increase current consumption when holding position, and cause heating of the motor.

DIP 10	DIP 11	Torque description	Approximate stall current (A)	Approximate stall torque (in-lbs)			
				RDL	RDM	RDH	RDF
Off	Off	Low	1.0	63	212	430	715
Off	On	Medium-low	1.5	72	236	522	832
On	Off	Medium-high	2.0	77	243	525	949
On	On	High	3.0	83	247	532	1067

DIP switches 10 and 11 set the actuator torque. These settings are adapted to the valve at the factory. Worn-in valves may require a higher torque setting after some time. The actuator will use 100% of available torque to try and reach maximum speed.



Note: Medium-high and high settings require voltage supply minimum values as follows:

- Supply voltage needs to be min 14 VDC for medium-high
- Supply voltage needs to be 16 VDC for high
- When operating above 20 VDC and 66% power, Duty cycle is reduced to 50% - 25% maximum. At these levels, the electronics produce more heat which must be dissipated (depending on environmental temperature)

DIP 3	Reserved for custom function.
DIP 4	Sets direction of offset (offset only required in RDH and RDF models).
DIP 5	Sets the highest amount of offset, typically 12°. NOTE: To set maximum offset DIPs 5,6, and 7 will need to be high for a total of 21°. The maximum offset can also be set differently at the factory (upon customer request).
DIP 6	Sets medium offset, typically 6°.
DIP 7	Sets the lowest amount of offset, typically 3°.
DIP 8	With DIP 8 in the ON position, the actuator will move to 4 positions. When DIP 8 is in the OFF position, the actuator is limited to three positions. DIP 8 also changes the function of the output signals. See p.9 for details.
DIP 9	Run / Calibrate Putting DIP 9 into the off position will disable the actuator positioning control, and the motor will not move regardless of the input signals. When DIP 9 is moved back into the on position, the actuator will perform its homing routine, and then move to the position commanded by the input signals.
DIP 12	DIP 12 sets the direction of rotation

Functionality

The MDx-AC-xxxDTx can operate as a 3-position or 4-position actuator. The 4th position is enabled by turning DIP 8 ON.

Direction of rotation and using input 1

To change the direction of rotation on the actuator change the setting on DIP 12 and cycle power to the actuator.



VERY IMPORTANT: Input 1 must always be used if only one input is used to operate the valve. When the actuator is operated using input 1 an automatic calibration is done every time the valve is actuated. This does not happen on input 2.

Inputs 1 & 2 (pins 1 & 2) are HIGH by default – a LOW signal must be sent to change the value.

Low	≤ 0.8 VDC	for all models
High	≥ 4.5 VDC	for MDx-AC-xxxDT and MDx-AC-xxxDT5
	≥ 20 VDC	for MDx-AC-xxxDT24



Sending a signal of more than 24 VDC may be harmful to the internal circuit board.

3-pos Functionality (DIP 8 OFF)

Input #1 (Pin 1)	Input #2 (Pin 2)	Action taken
High	High	Moves to or remains in centre position
Low	High	Moves to or remains in right position
High	Low	Moves to or remains in left position
Low	Low	Moves to or remains in left position (Input #2 has precedence over Input #1)
The feedback is as follows:		
Output #1 (Pin 3)	Output #2 (Pin 4)	Meaning
High	High	Valve is in centre position
High	Low	Valve is in right position
Low	High	Valve is in left position
Low	Low	Actuator is moving or has stalled and given up trying to reach a requested position. You may retry to reach any position by cycling both inputs one after the other. Repeated failures to reach position will require troubleshooting.

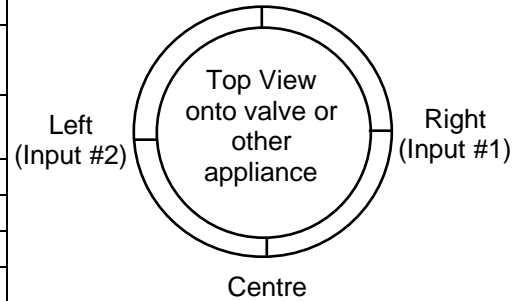

4-pos Functionality (DIP 8 ON)

Input #1 (Pin 1)	Input #2 (Pin 2)	Action taken
High	High	Moves to or remains in centre position
Low	High	Moves to or remains in right position
High	Low	Moves to or remains in left position
Low	Low	Moves to or remains in back position
The feedback is as follows:		
Output #1 (Pin 3)	Output #2 (Pin 4)	Meaning
Low	Low	Actuator is at requested position
High	Low	Actuator is moving
Low	High	Actuator has stalled. The stall can be cleared by making the actuator turn in the other direction. Repeated failures will require troubleshooting.

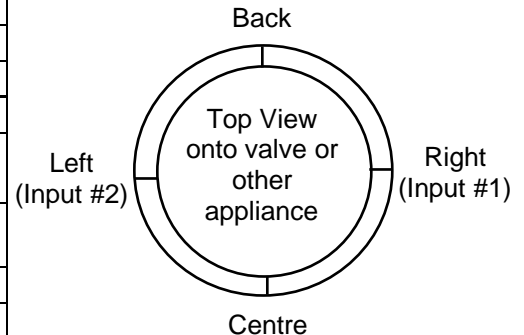

Calibration

The center position calibration routine can be initiated by switching DIP 9 momentarily “off” then “on”. This will cause the actuator to go through a series of movements to determine the proper center position. This function is useful if the actuator’s output gear gets manually rotated while the actuator is powered down and can’t properly realign to the center by itself.

Troubleshooting

Upon noticing a problem, your first step should almost always be to recalibrate the actuator by toggling DIP 9 while the actuator is powered. This alone can solve basic problems.

If the actuator does not move, try following these steps:

- 1) Re-calibrate the actuator. This will move the actuator regardless of what signal it is receiving.
- 2) A sticking valve may be the problem. Remove the valve from the actuator, and re-test the actuator.
- 3) Remove power. Re-check the wiring and the power/signal apparatus. Power actuator, and re-calibrate. If the problem persists, please call Rotork for technical support.

Any parts found to be defective should be examined and/or replaced by Rotork.

ACTUATOR DIMENSIONS

MDJ, MDL & MDM -AC-xxxDT models

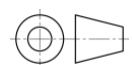
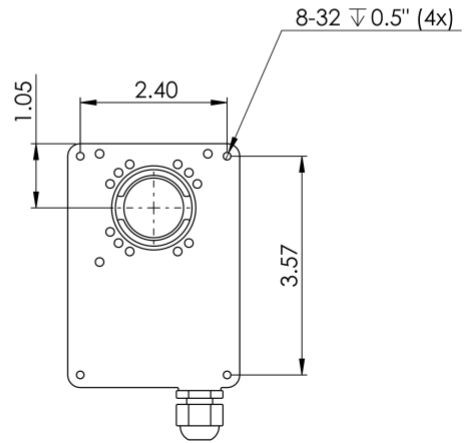
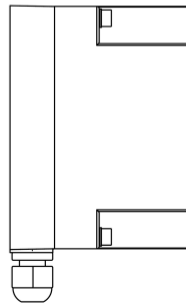
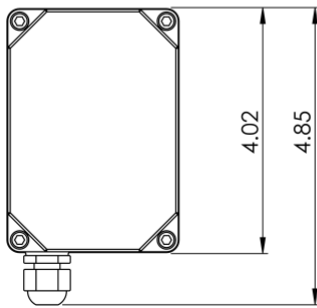
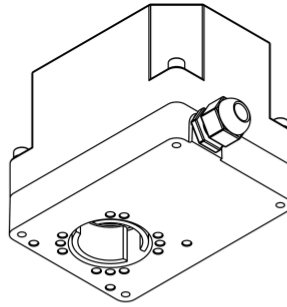
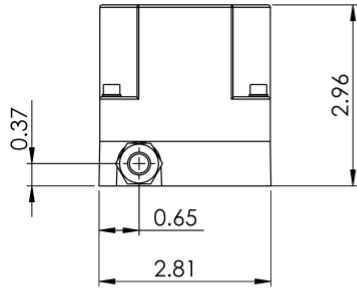

MDH-AC-xxxDT models

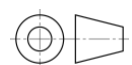
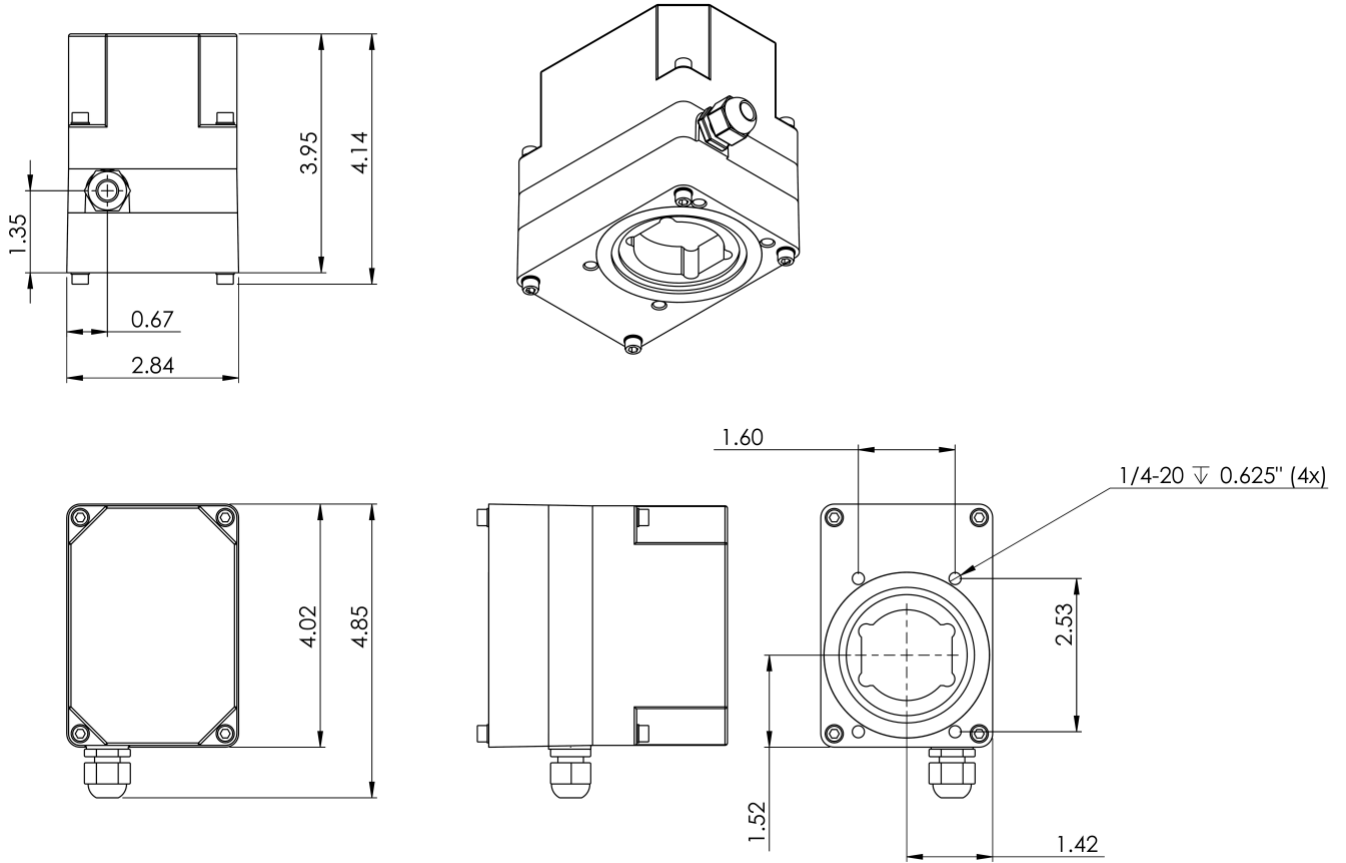

MDF-AC-xxxDT models

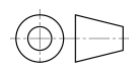
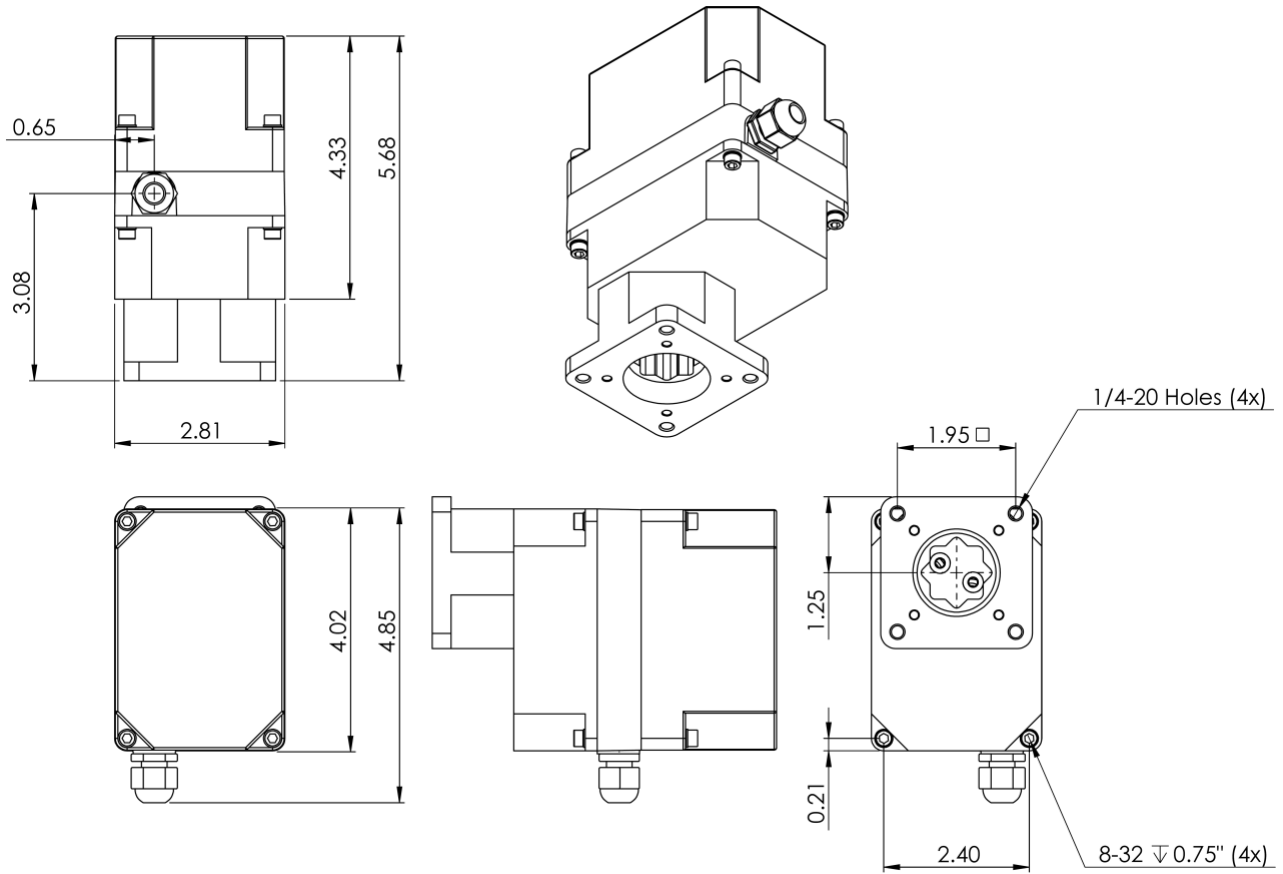

PART NUMBER BREAKDOWN

Full Part Number: **M** **D** - **AC** - **DT** - -

Base Enclosure	Positioning	Gear Train	Special Options	Enclosure Options	Wiring	Thermal Management	PCB	Mounting Kit	Valve Part Number
M		-	-					-	Valve Manufacturer's Part # / CU #
M	M-Series								0 No Valve or Mounting Kit 1 Mounting Kit, Customer Supplies Valve, does not send valve to Hanbay 2 Mounting Kit, Customer Supplies Valve, sends valve to Hanbay 3 Mounting Kit, Hanbay Provides Valve
C	Continuous								
D	Discrete								
J	Extra Low Torque								
L	Low Torque								
M	Medium Torque								
H	High Torque (Add. Gear Stage)								
F	F-Gear Stage (Add. Gear Stage)								
									AB Analog Signal Board AF Analog Signal Board Isolated with Feedback AI Analog Signal Board Isolated Input AS Modbus Control with Feedback DC24 Continuous TTL Board, 0V input / 24V feedback signal DC5 Continuous TTL Board, 0V Input / 5V feedback signal DT24 Discrete TTL Board, 0V Input / 24V feedback signal DT5 Discrete TTL Board, 0V Input / 5V feedback signal
									0 No Option FH Horizontal External Fan FV Vertical External Fan H Internal Heater FHH Horizontal External Fan & Internal Heater FVH Vertical External Fan & Internal Heater
									0 Cable Gland (Specify Cable & length at added cost) 4 Custom Dual Gauge Cable, 10ft. 5 TURCK 5 Position Connector w. 20' Cable and Plug 6 TURCK 6 Position Connector w. 20' Cable and Plug 7 TURCK 5 Position Connector Only 9 TURCK 6 Position Connector Only
									0 Standard Red Alloy Enclosure N Black Alloy Enclosure S Stainless Steel Enclosure
									0 No Special Options AC 110-240 VAC Power Supply B Battery Backup BS Bottom Stop G G-Stage Gate Valve (with MCM or MCL) HT High Temperature Mounting Kit L1 Linear 16 TPI L2 Linear 8 TPI M Manual Override P Position Indicator (Quarter-turn) PM Position Indicator (Multi-turn) QR Quick Release Mounting Kit

LABEL BREAKDOWN

Firmware Version

AF-1.05 } MM = Multiturn
 AB-1.05 } MML = Multiturn Low Torque
 AS-1.05 } MMUL = Multiturn Extra Low Torque
 } QM = Quarter turn
 } QM97 = Quarter turn 97°
 DT-2.01
 DC-2.01
 M-Dx V2.34

Actuator Supply Voltage

12-24 VDC @ 3.0 A or
 110-240 VAC @ 1.5 A

Circuit Board Version

Ax-8.09
 Dx-10.41
 Px-10.3

Actuator Series

M-Series or R-Series

rotork
HANBAY

 www.hanbayinc.com
 (336) 659 3400
 NC, 27103

M-Series 110-240 VAC 1.5A

Ax-8.09

AF-1.05MM

MCL-AC-040AF

POWER OFF UNIT BEFORE REMOVING COVER

Made in USA

S/N: 19103201-01

User Manual:



Actuator Part Number

Refer to part number breakdown
 for available options.

QR Code

Scan this QR code for a
 direct link to the user
 manual for your unit!

Actuator Serial Number

This serial number is unique for
 each individual unit and is directly
 tied to your order/invoice number.

As part of a process of on-going product development, Rotork reserves the right to amend and change specifications without prior notice. Published data may be subject to change. For the very latest version release, visit our website at www.rotork.com
 The name Rotork is a registered trademark. Rotork recognises all registered trademarks. Published and produced in the UK by Rotork. POLJB0424