

# rotork®

Keeping the World Flowing  
for Future Generations

## M series

MDx-B-xxxDT-10.41 user manual

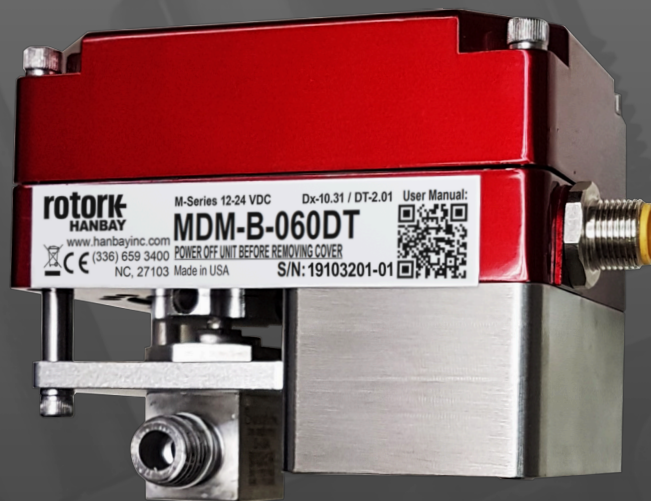

 **HANBAY INC.**  
A rotork® Brand

# MDx-B-xxxDT-10.41

(24 VDC; Battery Backup; TTL Control)

## USER MANUAL

### Contents

<b>INSTALLATION</b>	<b>3</b>
Mounting	3
Wiring	3
Power Supply and Current Draw	4
Control Signal and Feedback	4
<i>MDx-B-xxxDT and MDx-B-xxxDT5</i>	4
<i>MDx-B-xxxDT24</i>	5
<b>OPERATION</b>	<b>6</b>
DIP Switches	6
Functionality	7
Calibration	9
Troubleshooting	9
Battery Fail Safe Function	10
<i>Testing Battery Functionality</i>	10
<b>ACTUATOR DIMENSIONS</b>	<b>11</b>
<b>PART NUMBER BREAKDOWN</b>	<b>12</b>
<b>LABEL BREAKDOWN</b>	<b>13</b>

# INSTALLATION

## Mounting

In most cases, the actuator must be mounted and supported as shown in the image to the right. The mounting bracket is not supplied by Rotork.

Exceptionally, the actuator may be suspended on the tubing itself but ONLY if the application is vibration free and the tubing is minimum 1/4" dia. stainless.

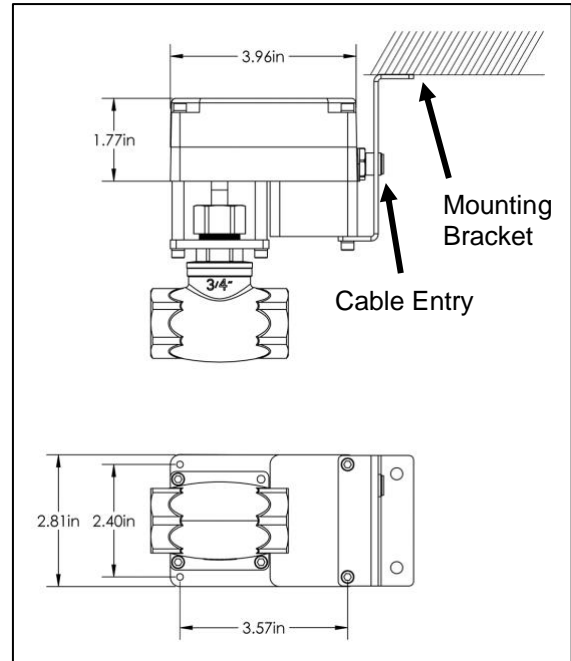

## Wiring

The actuator comes standard with a Turck 6 position connector and a 20' cable with plug. Cut the cable to the length required and then connect according to the following wire color schematic:

Wire colour schematic for "Turck6" cable:

Pin	Colour	Function
6	White	+24 VDC
5	Black	Power gnd.
4	Pink	Output TTL2
3	Grey	Output TTL1
2	Blue	Input TTL2
1	Brown	Input TTL1

If the Turck cable is not included in your actuator, connect the wires to the corresponding pins on the terminal block as indicated in the table and schematic below:

Pin	Function
6	Already Connected to battery board Connect +24 VDC wire to loose red cable with crimp connector
5	Already Connected to battery board Connect power ground wire to loose black cable with crimp connector
4	Output TTL2
3	Output TTL1
2	Input TTL2
1	Input TTL1

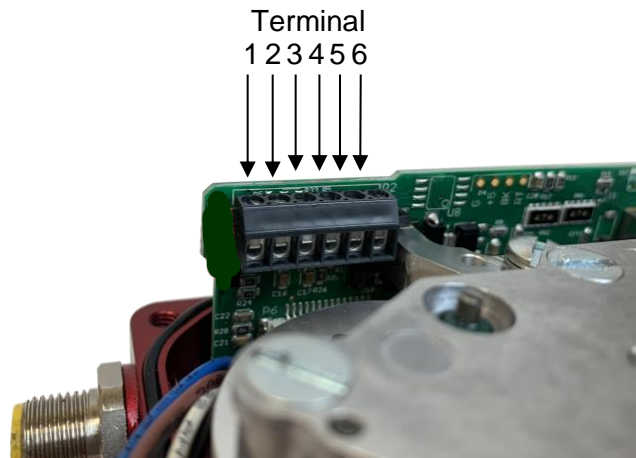

## Power Supply and Current Draw

The MDx-B-xxxDT can **ONLY** be connected to 24 VDC +/- 10%.

The current draw will range from minimum 100 mA to maximum 3 A while the actuator is active. When not moving, the actuator draws approx. 50 mA.

## Control Signal and Feedback

### MDx-B-xxxDT and MDx-B-xxxDT5

Actuators with part numbers MDx-B-xxxDT and MDx-B-xxxDT5 have the old standard 5 V TTL control and feedback signals. Locate the correct connection terminals/wires (as shown on the previous page), then set-up the PLC as shown below.

- Connect your input signal on positions 1 and 2 (brown and blue wires)  
**The input signals are high by default (+5 V).** To change the value, send a low signal (0 V ↔ pull to ground).  
 See the Functionality section for details
- Feedback is connected to positions 3 and 4 (grey and pink wires)  
 The maximum drive current is 2.5 mA.

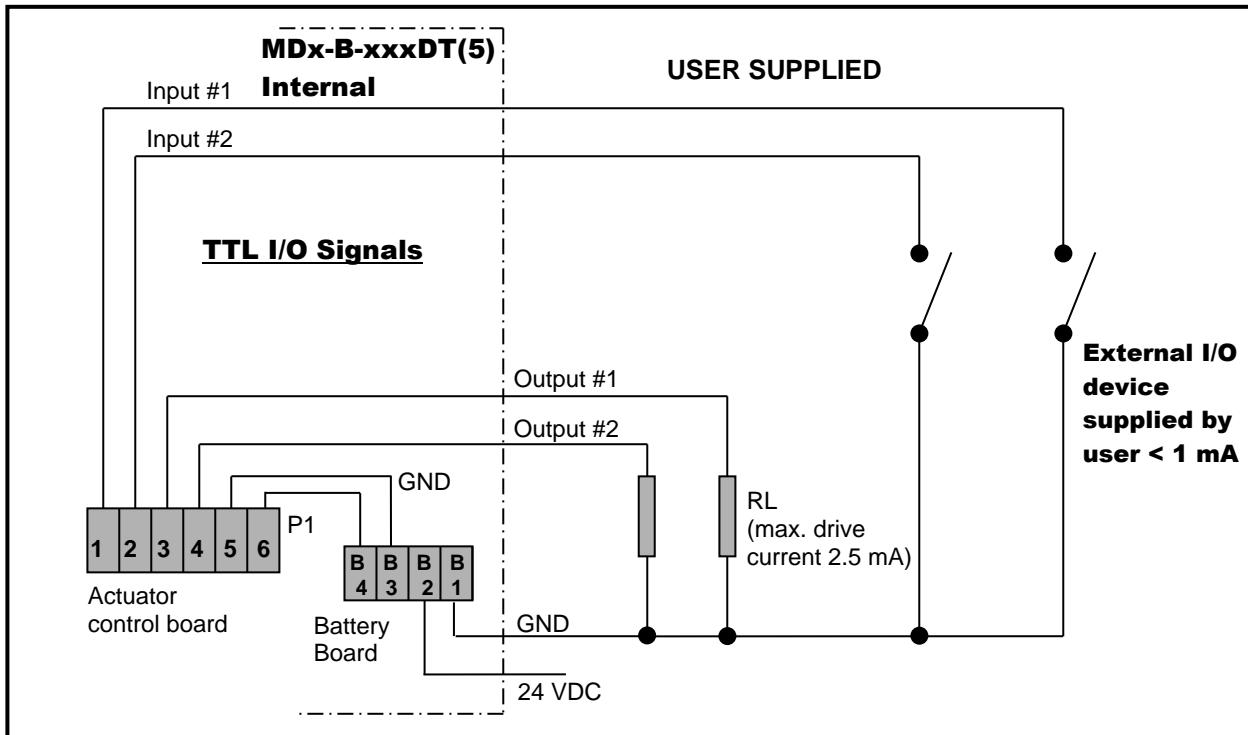

**MDx-B-xxxDT24**

Actuators with part numbers MDx-B-xxxDT24 have the new standard 24 V TTL control and feedback signals. Locate the correct connection terminals/wires (as shown on the previous page), then set-up the PLC as shown below.

- Connect your input signal on positions 1 and 2 (brown and blue wires)  
**The input signals are high by default (24 V).** To change the value, send a low signal (0 V ↔ pull to ground).  
 See the Functionality section for details.
- Feedback is connected to positions 3 and 4 (grey and pink wires)  
 The maximum drive current is 0.5 A.

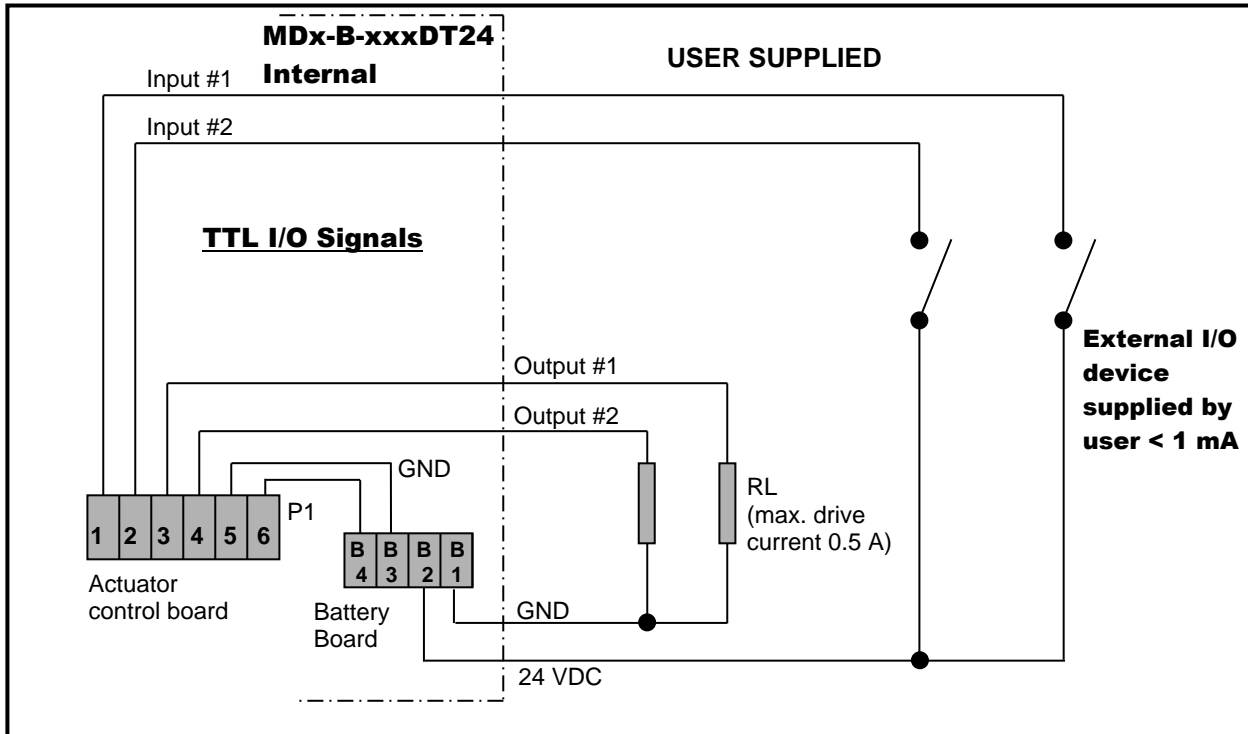

# OPERATION

## DIP Switches

The DIP switches allow you to change the settings on your actuator. To flip a switch, gently use a small flat-head screwdriver.

See the table below for DIP switch functionality.

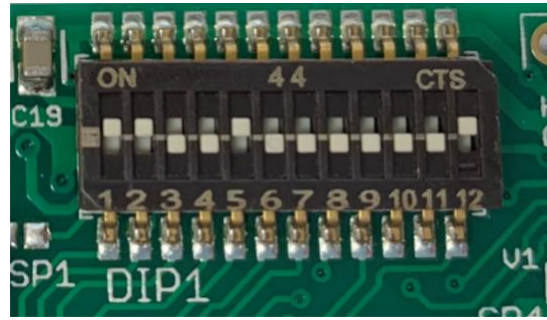

In this example DIPs 1, 2, 5 and 12 are on.

DIP 1	DIP 2	Description	Recommended Use
Off	Off	Fastest settling	Use only for low torque valves
Off	On	Medium-fast	Typical setting
On	Off	Medium-slow	Typical setting
On	On	Slowest settling	Use for high torque valves

DIP switches 1 and 2 set the actuator position control parameters. High settling speed settings are suitable for fast positioning of light valves. Longer settling times will allow heavier valves to reach their target positions; trying to use a fast settling setting on a high torque valve will increase current consumption when holding position, and cause heating of the motor.

DIP 10	DIP 11	Torque description	Approximate stall current (A)	Approximate stall torque (in-lbs)			
				MDL	MDM	MDH	MDF
Off	Off	Low	1.0	63	212	Not available with battery backup. Use RDH* instead. †	715
Off	On	Medium-low	1.5	72	236		832
On	Off	Medium-high	2.0	77	243		949
On	On	High	3.0	83	247		1067

\* Please see user manual RDx-B-xxxDT for more details.

† If the M-Series housing with MDH torque range (430-532 in-lbs) is essential, contact us about MDF-L.

DIP switches 10 and 11 set the actuator torque. These settings are adapted to the valve at the factory. Worn-in valves may require a higher torque setting after some time. The actuator will use 100% of available torque to try and reach maximum speed.



**Note:** When operating at or above 66% power, duty cycle is reduced to 50% - 25% maximum. At these levels, the electronics produce more heat which must be dissipated (depending on environmental temperature)

<b>DIP 3</b>	Reserved for custom function.
<b>DIP 4</b>	Sets direction of offset (offset only required in MDH and MDF models).
<b>DIP 5</b>	Sets the highest amount of offset, typically 12°. <b>NOTE:</b> To set maximum offset DIPs 5,6, and 7 will need to be high for a total of 21°. The maximum offset can also be set differently at the factory (upon customer request).
<b>DIP 6</b>	Sets medium offset, typically 6°.
<b>DIP 7</b>	Sets the lowest amount of offset, typically 3°.
<b>DIP 8</b>	With DIP 8 in the ON position, the actuator will move to 4 positions. When DIP 8 is in the OFF position, the actuator is limited to three positions. DIP 8 also changes the function of the output signals. See p.7 for details.
<b>DIP 9</b>	Run / Calibrate Putting DIP 9 into the off position will disable the actuator positioning control, and the motor will not move regardless of the input signals. When DIP 9 is moved back into the on position, the actuator will perform its homing routine, and then move to the position commanded by the input signals.
<b>DIP 12</b>	DIP 12 sets the direction of rotation

## Functionality

The MDx-B-xxxDT can operate as a 3-position or 4-position actuator. The 4<sup>th</sup> position is enabled by turning DIP 8 ON.

### Direction of rotation and using input 1

To change the direction of rotation on the actuator change the setting on DIP 12 and cycle power to the actuator.



**VERY IMPORTANT:** Input 1 must always be used if only one input is used to operate the valve. When the actuator is operated using input 1 an automatic calibration is done every time the valve is actuated. This does not happen on input 2.

Inputs 1 & 2 (pins 1 & 2) are HIGH by default – a LOW signal must be sent to change the value.

**Low**    ≤ 0.8 VDC      for all models  
**High**    ≥ 4.5 VDC      for MDx-B-xxxDT and MDx-B-xxxDT5  
              ≥ 20 VDC      for MDx-B-xxxDT24



**Sending a signal of more than 24 VDC may be harmful to the internal circuit board.**

**3-pos Functionality (DIP 8 OFF)**

Input #1 (Pin 1)	Input #2 (Pin 2)	Action taken
High	High	Moves to or remains in centre position
Low	High	Moves to or remains in right position
High	Low	Moves to or remains in left position
Low	Low	Moves to or remains in left position (Input #2 has precedence over Input #1)
<b>The feedback is as follows:</b>		
Output #1 (Pin 3)	Output #2 (Pin 4)	Meaning
High	High	Valve is in centre position
High	Low	Valve is in right position
Low	High	Valve is in left position
Low	Low	Actuator is moving or has stalled and given up trying to reach a requested position. You may retry to reach any position by cycling both inputs one after the other. Repeated failures to reach position will require troubleshooting.

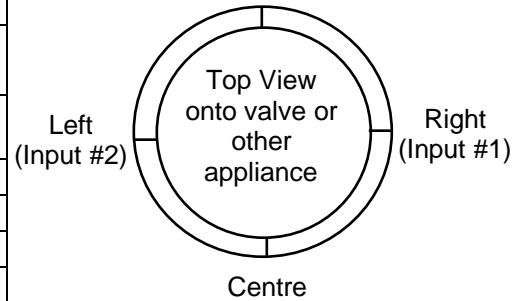

**4-pos Functionality (DIP 8 ON)**

Input #1 (Pin 1)	Input #2 (Pin 2)	Action taken
High	High	Moves to or remains in centre position
Low	High	Moves to or remains in right position
High	Low	Moves to or remains in left position
Low	Low	Moves to or remains in back position
<b>The feedback is as follows:</b>		
Output #1 (Pin 3)	Output #2 (Pin 4)	Meaning
Low	Low	Actuator is at requested position
High	Low	Actuator is moving
Low	High	Actuator has stalled. The stall can be cleared by making the actuator turn in the other direction. Repeated failures will require troubleshooting.

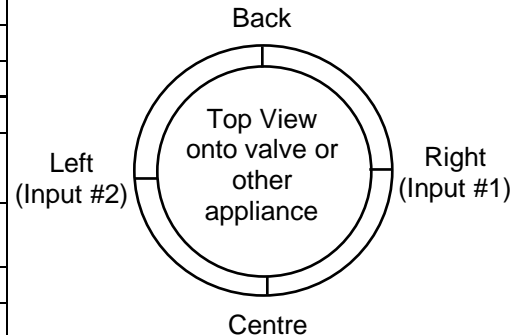



## Calibration

The center position calibration routine can be initiated by switching DIP 9 momentarily “off” then “on”. This will cause the actuator to go through a series of movements to determine the proper center position. This function is useful if the actuator’s output gear gets manually rotated while the actuator is powered down and can’t properly realign to the center by itself.

## Troubleshooting

Upon noticing a problem, your first step should almost always be to recalibrate the actuator by toggling DIP 9 while the actuator is powered. This alone can solve basic problems.

### **If the actuator does not move, try following these steps:**

- 1) Re-calibrate the actuator. This will move the actuator regardless of what signal it is receiving.
- 2) A sticking valve may be the problem. Remove the valve from the actuator, and re-test the actuator.
- 3) Remove power. Re-check the wiring and the power/signal apparatus. Power actuator, and re-calibrate. If the problem persists, please call Rotork for technical support.

## Battery Fail Safe Function

1. In the event of a loss of power or signal, the battery will maintain power to the P1 processor and trigger the actuator to move the valve to its designated fail-safe position, using power from the battery.
2. Once the valve has reached its fail-safe position, and after about one minute, the P1 processor will go into sleep mode to preserve the battery life.
3. The actuator will not respond to commands until the power supply is restored.

**Note:** The battery will maintain a charge for up to 2 months without power being applied. The fail-safe actuation can be performed for 30 cycles on the charge available in the battery. During normal operation, from totally discharged, the batteries will take 2 hours to re-charge.



If in a critical fail-safe application, the battery function should be tested monthly.

## Testing Battery Functionality

- The batteries will be continuously on charge when power is available to the actuator.
- Regardless of application, the fail-safe function should be tested monthly by signaling the unit to the position opposite the fail position, removing the power to the actuator and observing whether the actuator reaches the desired fail position.
- The battery voltage can be measured with a multimeter set for DC volt measurement.

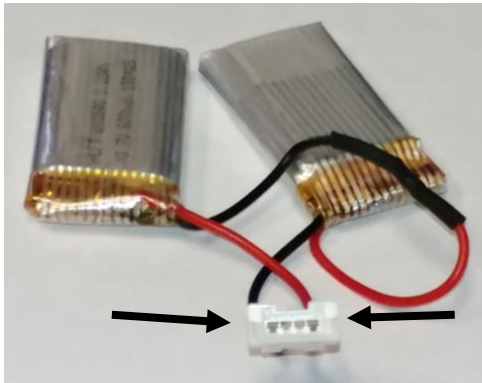

Measure battery voltage between the connector terminals.  
Value should be:  
 $7.9 \pm 0.5$  VDC



# ACTUATOR DIMENSIONS

## MDL & MDM -B-xxxAx models

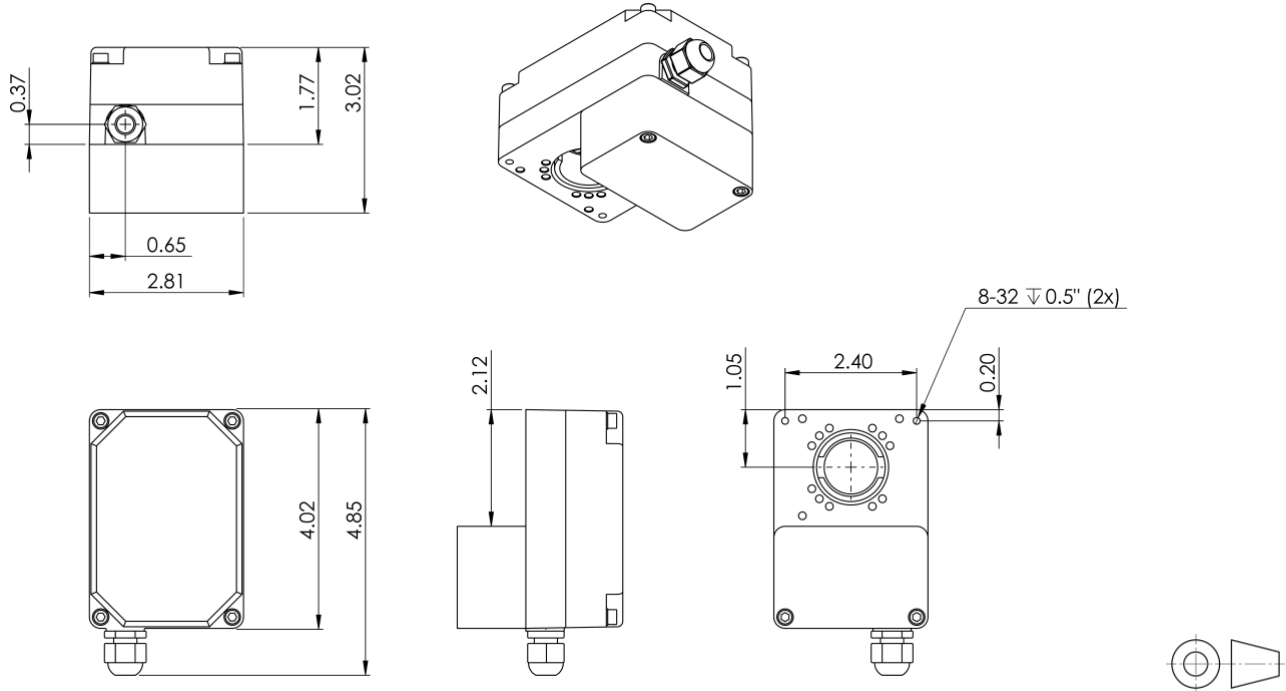

## MDF-B-xxxAx models

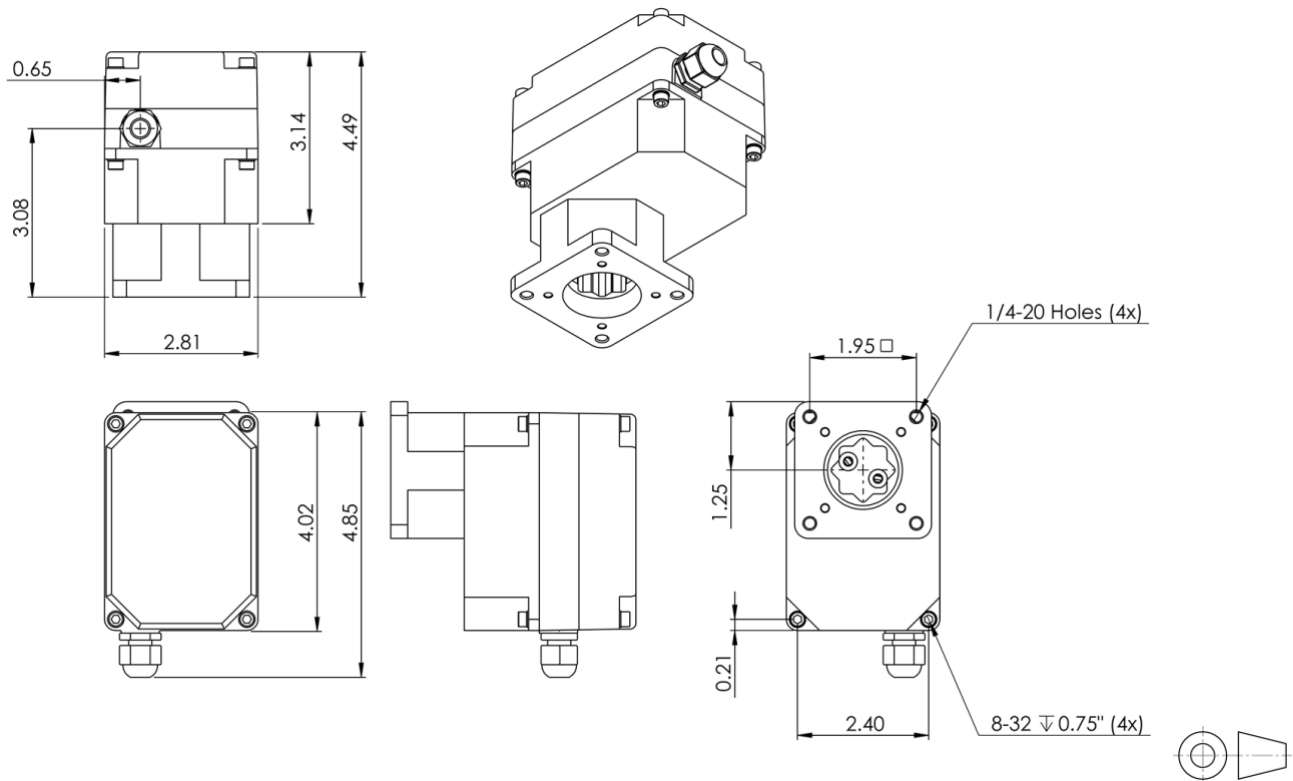

# PART NUMBER BREAKDOWN

Full Part Number: 

<b>M</b>	<b>D</b>	
----------	----------	--

 - 

<b>B</b>			
----------	--	--	--

**DT** - 

--	--

 - 

--

	Base Enclosure	Positioning	Gear Train	Special Options	Enclosure Options	Wiring	Thermal Management	PCB	Mounting Kit	Valve Part Number
<b>M</b>			-						-	Valve Manufacturer's Part # / CU #
<b>M</b>	M-Series									<b>0</b> No Valve or Mounting Kit <b>1</b> Mounting Kit, Customer Supplies Valve, does not send valve to Hanbay <b>2</b> Mounting Kit, Customer Supplies Valve, sends valve to Hanbay <b>3</b> Mounting Kit, Hanbay Provides Valve
	<b>C</b>	Continuous								
	<b>D</b>	Discrete								
	<b>J</b>	Extra Low Torque								
	<b>L</b>	Low Torque								
	<b>M</b>	Medium Torque								
	<b>H</b>	High Torque (Add. Gear Stage)								
	<b>F</b>	F-Gear Stage (Add. Gear Stage)								
										<b>AB</b> Analog Signal Board <b>AF</b> Analog Signal Board Isolated with Feedback <b>AI</b> Analog Signal Board Isolated Input <b>AS</b> Modbus Control with Feedback <b>DC24</b> Continuous TTL Board, 0V input / 24V feedback signal <b>DC5</b> Continuous TTL Board, 0V Input / 5V feedback signal <b>DT24</b> Discrete TTL Board, 0V Input / 24V feedback signal <b>DT5</b> Discrete TTL Board, 0V Input / 5V feedback signal
										<b>0</b> No Option <b>FH</b> Horizontal External Fan <b>FV</b> Vertical External Fan <b>H</b> Internal Heater <b>FHH</b> Horizontal External Fan & Internal Heater <b>FVH</b> Vertical External Fan & Internal Heater
										<b>0</b> Cable Gland (Specify Cable & length at added cost) <b>4</b> Custom Dual Gauge Cable, 10ft. <b>5</b> TURCK 5 Position Connector w. 20' Cable and Plug <b>6</b> TURCK 6 Position Connector w. 20' Cable and Plug <b>7</b> TURCK 5 Position Connector Only <b>9</b> TURCK 6 Position Connector Only
										<b>0</b> Standard Red Alloy Enclosure <b>N</b> Black Alloy Enclosure <b>S</b> Stainless Steel Enclosure
										<b>0</b> No Special Options <b>AC</b> 110-240 VAC Power Supply <b>B</b> Battery Backup <b>BS</b> Bottom Stop <b>G</b> G-Stage Gate Valve (with MCM or MCL) <b>HT</b> High Temperature Mounting Kit <b>L1</b> Linear 16 TPI <b>L2</b> Linear 8 TPI <b>M</b> Manual Override <b>P</b> Position Indicator (Quarter-turn) <b>PM</b> Position Indicator (Multi-turn) <b>QR</b> Quick Release Mounting Kit

## LABEL BREAKDOWN

### Firmware Version

AF-1.05 } MM = Multiturn  
 AB-1.05 } MML = Multiturn Low Torque  
 AS-1.05 } MMUL = Multiturn Extra Low Torque  
 QM = Quarter turn  
 QM97 = Quarter turn 97°

DT-2.01  
 DC-2.01  
 M-Dx V2.34

### Actuator Supply Voltage

12-24 VDC @ 3.0 A or  
 110-240 VAC @ 1.5 A

### Circuit Board Version

Ax-8.09  
 Dx-10.41  
 Px-10.3

### Actuator Series

M-Series or R-Series

**rotork**  
**HANBAY**

www.hanbayinc.com  
 (336) 659 3400  
 NC, 27103



M-Series

24 VDC 3.0A

Dx-10.41

/ DT-2.01

**MDM-B-060DT24**

POWER OFF UNIT BEFORE REMOVING COVER

Made in USA

S/N: 19103201-01

User Manual:



### Actuator Part Number

Refer to part number breakdown for available options.

### QR Code

Scan this QR code for a direct link to the user manual for your unit!

### Actuator Serial Number

This serial number is unique for each individual unit and is directly tied to your order/invoice number.

As part of a process of on-going product development, Rotork reserves the right to amend and change specifications without prior notice. Published data may be subject to change. For the very latest version release, visit our website at www.rotork.com  
 The name Rotork is a registered trademark. Rotork recognises all registered trademarks. Published and produced in the UK by Rotork. POLJB0424