

# rotork®

Keeping the World Flowing  
for Future Generations

## M series

MCx-xxxDC-10.41 user manual



 **HANBAY INC.**  
A rotork® Brand

**MCx-xxxDC-10.41**  
(12-24 VDC; TTL Control for Multi-Turn Valves)

**USER MANUAL**

*Contents*

<b>MEANING OF SYMBOLS</b>	<b>3</b>
<b>INSTALLATION</b>	<b>3</b>
Environmental Conditions	3
Mounting	4
Wiring	4
Power Supply and Current Draw	5
Control Signal and Feedback	5
<i>MDx-xxxDC and MDx-xxxDC5</i>	5
<i>MCx-xxxDC24</i>	6
<b>OPERATION</b>	<b>7</b>
DIP Switches	7
Functionality	8
Calibration	9
Troubleshooting	9
<b>ACTUATOR DIMENSIONS</b>	<b>10</b>
<b>PART NUMBER BREAKDOWN</b>	<b>12</b>
<b>LABEL BREAKDOWN</b>	<b>13</b>

## MEANING OF SYMBOLS



The exclamation point within an equilateral triangle is intended to alert the user to the presence of important operating and maintenance (servicing) instructions in the literature accompanying the product.



The Lightning Flash with arrowhead symbol within an equilateral triangle, is intended to alert the user to the presence of un-insulated "dangerous voltage" within the product enclosure that may be of sufficient magnitude to constitute a risk of shock to persons.

## INSTALLATION

The safety of any system incorporating the equipment is the responsibility of the assembler of the system.

### Environmental Conditions

The M-Series actuator has an IP66 rating but is recommended for indoor use in environments with a relative humidity below 80%. For outdoor use, or for use in higher humidity environments, please consider the equivalent R-Series actuator with its IP68 rating.

The ambient temperature range for the standard M-Series is -20 to 40 °C (-4 to 104 °F).  
The internal heater option shifts the temperatures to a lower range of -40 to 40 °C (-40 to 104 °F).

The standard M-Series has been approved for use at altitudes of up to 2000 m.

## Mounting

In most cases, the actuator must be mounted and supported as shown in the image to the right. The mounting bracket is not supplied by Rotork.

Exceptionally, the actuator may be suspended on the tubing itself but ONLY if the application is vibration free and the tubing is minimum 1/4" dia. stainless.

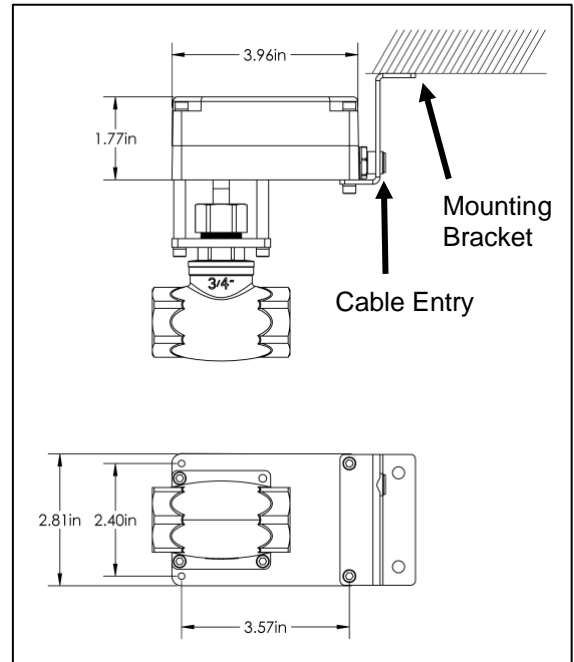

## Wiring

The actuator comes standard with a Turck 6 position connector and a 20' cable with plug. Cut the cable to the length required and then connect according to the following wire color schematic:

### Wire colour schematic for "Turck6" cable:

Pin	Colour	Function
6	White	+24 VDC
5	Black	Power gnd.
4	Pink	Output TTL2
3	Grey	Output TTL1
2	Blue	Input TTL2
1	Brown	Input TTL1

If the Turck cable is not included in your actuator, connect the wires to the corresponding pins on the terminal block as indicated in the schematic:

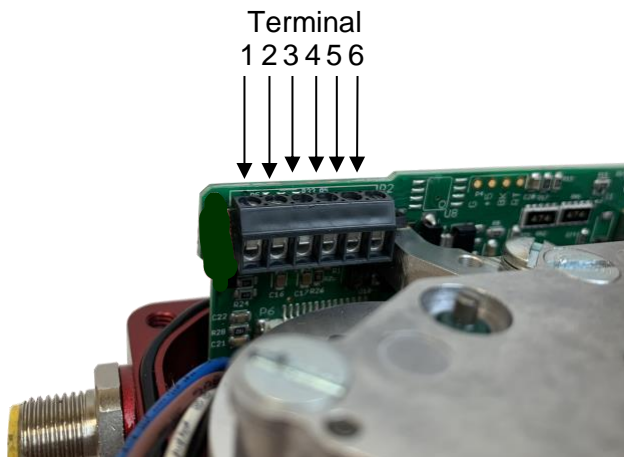

## Power Supply and Current Draw

The **MCx-xxxDC** may be connected to voltages ranging within 12-24 VDC. The AC supply to the actuator must be limited by a 1.5 A fuse or circuit breaker; it is recommended to have this installed near the actuator.

The current draw will range from minimum 100 mA to maximum 3 A while the actuator is active. When not moving, the actuator draws approx. 50 mA.

## Control Signal and Feedback

### MCx-xxxDC and MCx-xxxDC5

Actuators with part numbers MCx-xxxDC and MCx-xxxDC5 have the old standard 5 V TTL control and feedback signals. Locate the correct connection terminals/wires (as shown on the previous page), then set-up the PLC as shown below.

- Connect your input signal on positions 1 and 2 (brown and blue wires)  
**The input signals are high by default (+5 V).** To change the value, send a low signal (0 V ↔ pull to ground).  
 See the Functionality section for details
- Feedback is connected to positions 3 and 4 (grey and pink wires)  
 The maximum drive current is 2.5 mA.

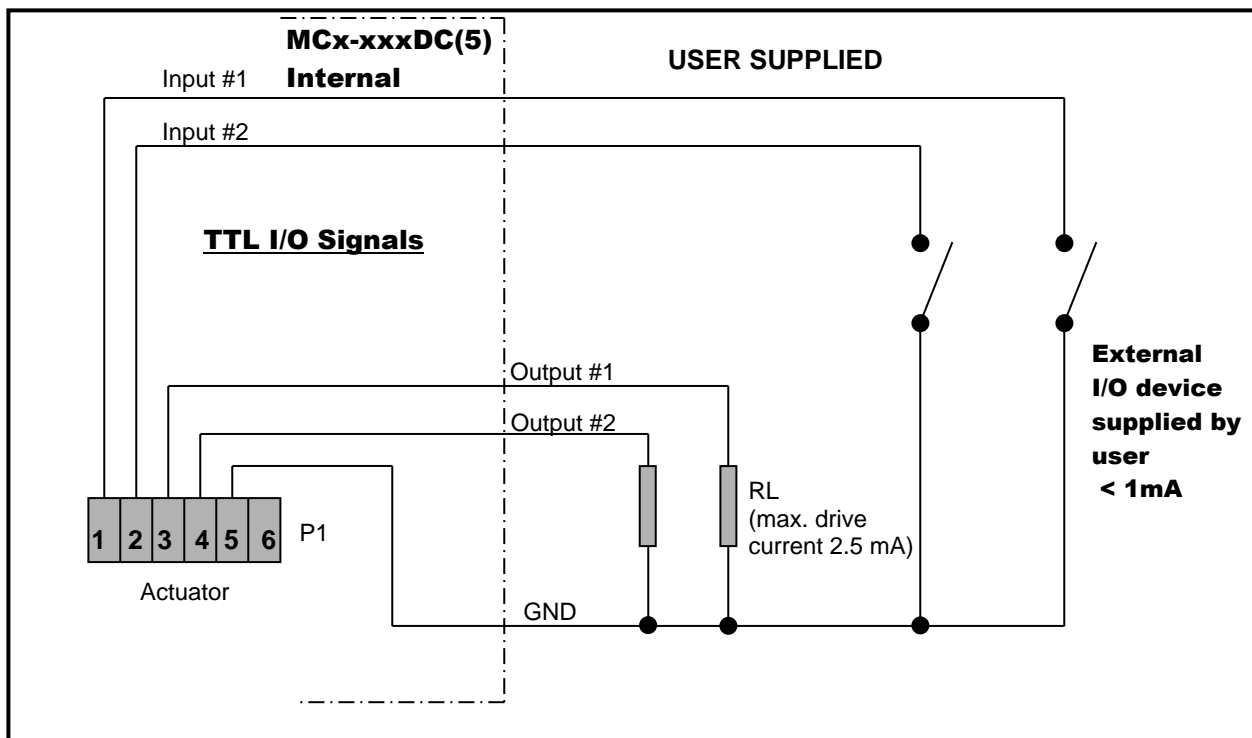

**MCx-xxxDC24**

Actuators with part numbers MCx-xxxDC24 have the new standard 24 V TTL control and feedback signals. Locate the correct connection terminals/wires (as shown on the previous page), then set-up the PLC as shown below.

- Connect your input signal on positions 1 and 2 (brown and blue wires)  
**The input signals are high by default (24 V).** To change the value, send a low signal (0 V ↔ pull to ground).  
 See the Functionality section for details.
- Feedback is connected to positions 3 and 4 (grey and pink wires)  
 The maximum drive current is 0.5 A.

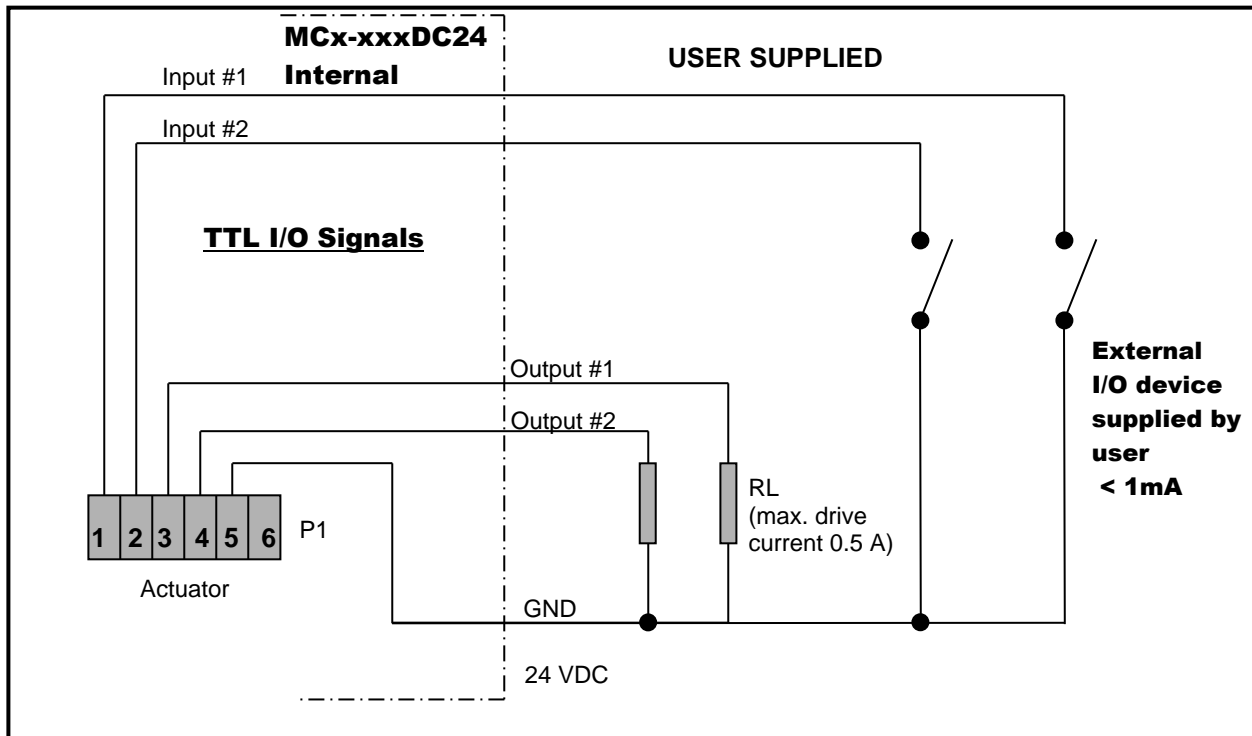

# OPERATION

## DIP Switches

The DIP switches allow you to change the settings on your actuator. To flip a switch, gently use a small flat-head screwdriver.

See the table below for DIP switch functionality.

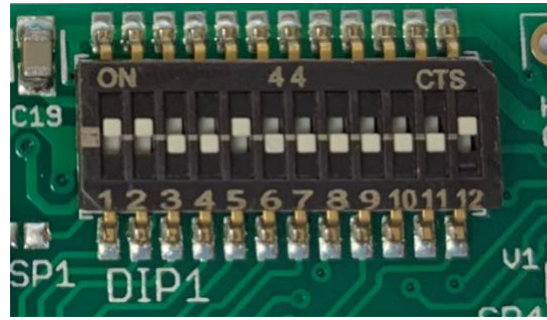

In this example DIPs 1, 2, 5 and 12 are on.

DIP 1	DIP 2	Description	Recommended Use
Off	Off	Fastest settling	Use only for low torque valves
Off	On	Medium-fast	Typical setting
On	Off	Medium-slow	Typical setting
On	On	Slowest settling	Use for high torque valves

DIP switches 1 and 2 set the actuator position control parameters. High settling speed settings are suitable for fast positioning of light valves. Longer settling times will allow heavier valves to reach their target positions; trying to use a fast settling setting on a high torque valve will increase current consumption when holding position, and cause heating of the motor.

DIP 10	DIP 11	Torque description	Approximate stall current (A)	Approximate stall torque (in-lbs)			
				MCL-xxxDC	MCM-xxxDC	MCH-xxxDC	MCF-xxxDC
Off	Off	Low	1.0	63	212	430	715
Off	On	Medium-low	1.5	72	236	522	832
On	Off	Medium-high	2.0	77	243	525	949
On	On	High	3.0	83	247	532	1067

DIP switches 10 and 11 set the actuator torque. These settings are adapted to the valve at the factory. Worn-in valves may require a higher torque setting after some time. The actuator will use 100% of available torque to try and reach maximum speed.



**Note:** Medium-high and high settings require voltage supply minimum values as follows:

- Supply voltage needs to be min 14 VDC for medium-high
- Supply voltage needs to be 16 VDC for high
- When operating above 20 VDC and 66% power, Duty cycle is reduced to 50% - 25% maximum. At these levels, the electronics produce more heat which must be dissipated (depending on environmental temperature)

DIPs 3-8	Reserved for custom functions.
DIP 9	Run / Calibrate Putting DIP 9 into the off position will disable the actuator positioning control, and the motor will not move regardless of the input signals. When DIP 9 is moved back into the on position, the actuator will perform its homing routine, and then move to the position commanded by the input signals.
DIP 12	DIP 12 sets the direction of rotation

## Functionality

The MCx-xxxDC operates as a continuous TTL. It can open or close to end positions or move to the center position.

### Direction of rotation

To change the direction of rotation on the actuator change the setting on DIP 12 and cycle power to the actuator.

Inputs 1 & 2 (pins 1 & 2) are HIGH by default – a LOW signal must be sent to change the value.

**Low**     $\leq 0.8$  VDC    for all models  
**High**    $\geq 4.5$  VDC    for MCx-xxxDC and MCx-xxxDC5  
              $\geq 20$  VDC    for MCx-xxxDC24



**Sending a signal of more than 24 VDC may be harmful to the internal circuit board.**

Input #1 (Pin 1)	Input #2 (Pin 2)	Action taken
High	High	Does not move
Low	High	Moves clockwise [closes the valve]
High	Low	Moves counterclockwise [opens the valve]
Low	Low	Moves to midway point between fully open and fully closed
<b>The feedback is as follows</b>		
Output #1 (Pin 3)	Output #2 (Pin 4)	Meaning
High	High	Actuator is standing still or moving in its range
High	Low	Valve is at the fully closed position
Low	High	Valve is at the fully open position
Low	Low	Valve is at the midway position

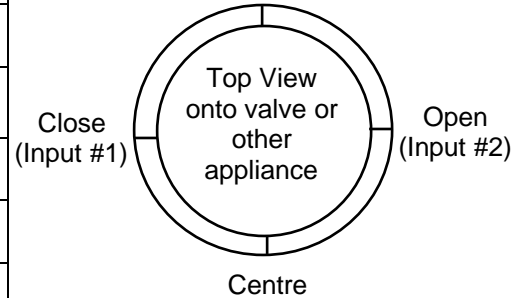



## Calibration

The center position calibration routine can be initiated by switching DIP 9 momentarily “off” then “on”. This will cause the actuator to go through a series of movements to determine the fully open and fully closed positions of the valve. This function should be used if the valve was decoupled from the actuator or if the actuator was turned manually while the power was off.

## Troubleshooting

Upon noticing a problem, your first step should almost always be to recalibrate the actuator by toggling DIP 9 while the actuator is powered. This alone can solve basic problems.

### **If the actuator does not move, try following these steps:**

- 1) Re-calibrate the actuator. This will move the actuator regardless of what signal it is receiving.
- 2) A sticking valve may be the problem. Remove the valve from the actuator, and re-test the actuator.
- 3) Remove power. Re-check the wiring and the power/signal apparatus. Power actuator, and re-calibrate. If the problem persists, please call Rotork for technical support.

**Any parts found to be defective should be examined and/or replaced by Rotork.**

# ACTUATOR DIMENSIONS

## MCJ, MCL & MCM -xxxDC models

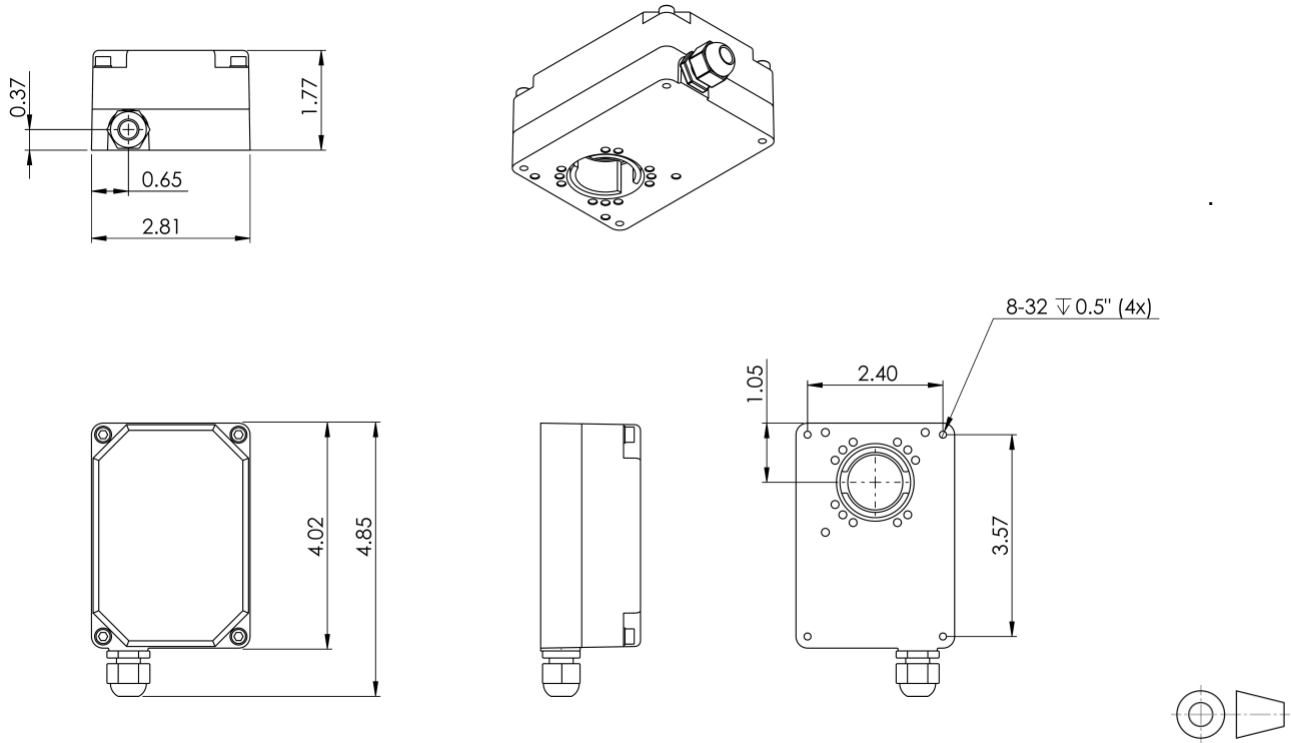

## MCH-xxxDC models

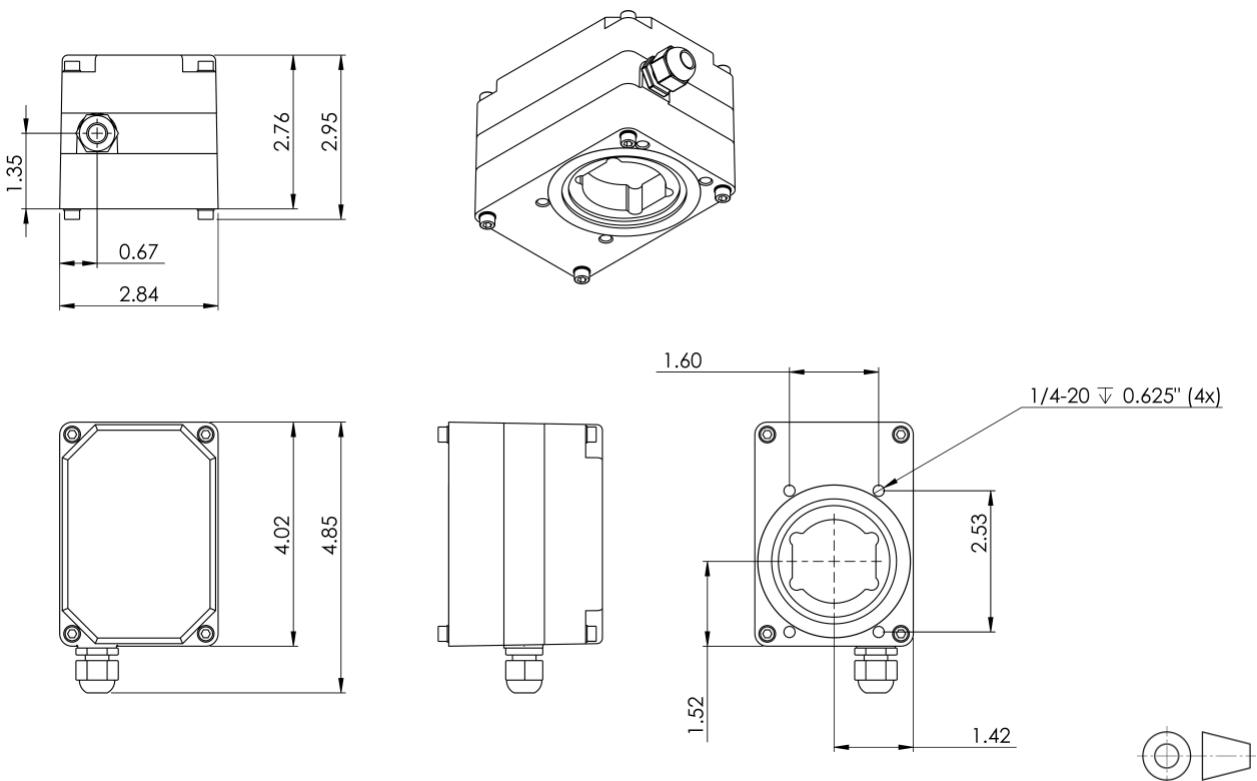

**MCF-xxxDC models**

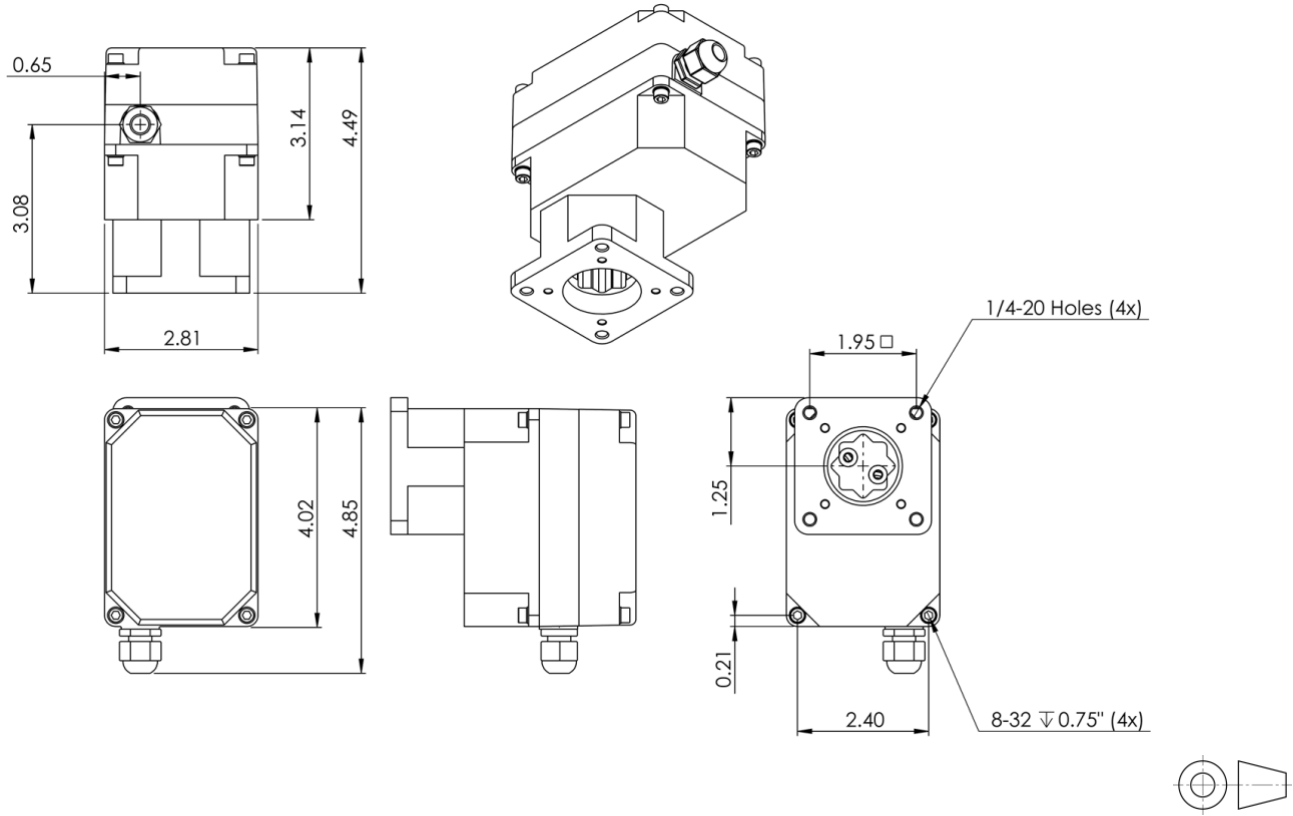

# PART NUMBER BREAKDOWN

Full Part Number:

<b>M</b>	<b>C</b>		-		-			<b>DC</b>	-		-	
----------	----------	--	---	--	---	--	--	-----------	---	--	---	--

	<i>Base Enclosure</i>	<i>Positioning</i>	<i>Gear Train</i>	<i>Special Options</i>	<i>Enclosure Options</i>	<i>Wiring</i>	<i>Thermal Management</i>	<i>PCB</i>	<i>Mounting Kit</i>	<i>Valve Part Number</i>
<b>M</b>			-						-	Valve Manufacturer's Part # / CU #
<b>M</b>	M-Series									<b>0</b> No Valve or Mounting Kit <b>1</b> Mounting Kit, Customer Supplies Valve, does not send valve to Hanbay <b>2</b> Mounting Kit, Customer Supplies Valve, sends valve to Hanbay <b>3</b> Mounting Kit, Hanbay Provides Valve
<b>C</b>	Continuous									
<b>D</b>	Discrete									
<b>J</b>	Extra Low Torque									
<b>L</b>	Low Torque									
<b>M</b>	Medium Torque									
<b>H</b>	High Torque (Add. Gear Stage)									
<b>F</b>	F-Gear Stage (Add. Gear Stage)									
										<b>AB</b> Analog Signal Board <b>AF</b> Analog Signal Board Isolated with Feedback <b>AI</b> Analog Signal Board Isolated Input <b>AS</b> Modbus Control with Feedback <b>DC24</b> Continuous TTL Board, 0V input / 24V feedback signal <b>DC5</b> Continuous TTL Board, 0V Input / 5V feedback signal <b>DT24</b> Discrete TTL Board, 0V Input / 24V feedback signal <b>DT5</b> Discrete TTL Board, 0V Input / 5V feedback signal
										<b>0</b> No Option <b>FH</b> Horizontal External Fan <b>FV</b> Vertical External Fan <b>H</b> Internal Heater <b>FHH</b> Horizontal External Fan & Internal Heater <b>FVH</b> Vertical External Fan & Internal Heater
										<b>0</b> Cable Gland (Specify Cable & length at added cost) <b>4</b> Custom Dual Gauge Cable, 10ft. <b>5</b> TURCK 5 Position Connector w. 20' Cable and Plug <b>6</b> TURCK 6 Position Connector w. 20' Cable and Plug <b>7</b> TURCK 5 Position Connector Only <b>9</b> TURCK 6 Position Connector Only
										<b>0</b> Standard Red Alloy Enclosure <b>N</b> Black Alloy Enclosure <b>S</b> Stainless Steel Enclosure
										<b>0</b> No Special Options <b>AC</b> 110-240 VAC Power Supply <b>B</b> Battery Backup <b>BS</b> Bottom Stop <b>G</b> G-Stage Gate Valve (with MCM or MCL) <b>HT</b> High Temperature Mounting Kit <b>L1</b> Linear 16 TPI <b>L2</b> Linear 8 TPI <b>M</b> Manual Override <b>P</b> Position Indicator (Quarter-turn) <b>PM</b> Position Indicator (Multi-turn) <b>QR</b> Quick Release Mounting Kit

## LABEL BREAKDOWN

### Firmware Version

AF-1.05 } MM = Multiturn  
 AB-1.05 } MML = Multiturn Low Torque  
 AS-1.05 } MMUL = Multiturn Extra Low Torque  
 QM = Quarter turn  
 QM97 = Quarter turn 97°  
 DT-2.01  
 DC-2.01  
 M-Dx V2.34

### Actuator Supply Voltage

12-24 VDC @ 3.0 A or  
 110-240 VAC @ 1.5 A

### Circuit Board Version

Ax-8.09  
 Dx-10.41  
 Px-10.3

### Actuator Series

M-Series or R-Series



### Actuator Part Number

Refer to part number breakdown for available options.

### QR Code

Scan this QR code for a direct link to the user manual for your unit!

### Actuator Serial Number

This serial number is unique for each individual unit and is directly tied to your order/invoice number.

As part of a process of on-going product development, Rotork reserves the right to amend and change specifications without prior notice. Published data may be subject to change. For the very latest version release, visit our website at [www.rotork.com](http://www.rotork.com). The name Rotork is a registered trademark. Rotork recognises all registered trademarks. Published and produced in the UK by Rotork. POLJB0424