



## **Failure Modes, Effects and Diagnostic Analysis**

Project:

Bifold VBP, PPV, and HIPEX Series of High Flow Valves

Company:

Bifold Fluidpower Ltd.  
Chadderton, Manchester  
United Kingdom

Contract Number: Q23/05-152

Report No.: BIF 09/10-25 R002

Version V3, Revision R3, August 2, 2023

Robert Gavin



## Management Summary

This report summarizes the results of the hardware assessment in the form of a Failure Modes, Effects, and Diagnostic Analysis (FMEDA) of the Bifold VBP, PPV, and HIPEX Series of High Flow Valves. A Failure Modes, Effects, and Diagnostic Analysis is one of the steps to be taken to achieve functional safety certification per IEC 61508 of a device. From the FMEDA, failure rates are determined. The FMEDA that is described in this report concerns only the hardware of the Bifold VBP, PPV, and HIPEX Series of High Flow Valves. For full functional safety certification purposes all requirements of IEC 61508 must be considered.

The VBP Series Volume Boosters convert a low volume pressure signal into a 1:1 ratio high volume output. It is specifically designed for both modulating and On - Off pilot pressure signals. When a low volume pilot pressure signal of 2 to 10 bar g is applied to the sensing port, the main valve assembly opens to allow high volume flow from the main inlet port to the outlet port. When the sensing assembly detects that the outlet pressure is equal to the pilot pressure, the main valve moves to the 'all ports blocked' rest position and will remain in this position until there is a change in the pilot pressure or outlet pressure. If the sensing head detects that the outlet is higher than the pilot pressure, the high flow exhaust opens to vent the excess pressure. If the sensing head detects that the outlet pressure is too low, the main valve opens to recharge the system to the correct 1:1 ratio pressure. For functional safety applications only the on-off mode of operation is considered.

The PPV Series Pneumatic Pilot Valves allow a low volume pressure signal to control a high volume output. When a low volume pilot pressure signal is applied to the pilot port, the main valve assembly opens to allow high volume flow from the main inlet port to the outlet port. These valves are generally used to control pneumatic flow to and from an actuator, or to dump large volumes of air.

The HIPEX Valves is a quick exhaust valve designed for the purpose of providing a high volume exhaust capability. With pilot pressure applied to the pilot port the input port is blocked. When the pilot pressure is released the input port if connected to a high-volume capacity exhaust port. The input is also fed back against the pilot pressure. This enables the HIPEC Valve to also serve as a pressure relief valve. If the input pressure exceeds the pilot pressure the input port will open exhausting the input pressure until it is once again equal to the pilot pressure. The FMEDA only considered the quick exhaust function of the HIPEX Valves.

Table 1 gives an overview of the different versions that were considered in this FMEDA of the Bifold VBP, PPV, and HIPEX Series of High Flow Valves.

**Table 1 Version Overview**

Port Size	Description
1½ & 2 inch	Standard Volume Booster – VBP-24 and VBP-32 Series
½, 1, 1½ & 2 inch	Pneumatic Pilot Valve – PPV-08, -16, -24, and -32 Series
1½ & 2 inch	HIPEX Valve – HIPEX-24 and HIPEX-32 Series

Table 2 gives an overview of the different versions that were considered in the FMEDA of the Bifold VBP, PPV, and HIPEX Series of High Flow Valves.

**Table 2 Version Overview**



Model	Functional Safety Configuration
Standard Volume Booster	De-Energize to trip
Pneumatic Pilot Valves – NU (Block After Bleed)	De-Energize to trip
HIPEX Valves	De-Energize to trip
Standard Volume Booster	Energize to trip
Pneumatic Pilot Valves – NU (Block After Bleed)	Energize to trip

Energize to trip applications failure rates do not take into account the loss of air supply to the booster.

The Bifold VBP, PPV, and HIPEX Series of High Flow Valves is classified as a device that is part of a Type A<sup>1</sup> element according to IEC 61508, having a hardware fault tolerance of 0.

The failure rate data used for this analysis meets the *exida* criteria for Route 2<sub>H</sub>. See Section 5.2. Therefore, the Bifold VBP, PPV, and HIPEX Series of High Flow Valves can be classified as a 2<sub>H</sub> device when the listed failure rates are used. When 2<sub>H</sub> data is used for all of the devices in an element, then the element meets the hardware architectural constraints up to SIL 2 at HFT=0 (or SIL 3 @ HFT=1) per Route 2<sub>H</sub>. If Route 2<sub>H</sub> is not applicable for the entire final element, the architectural constraints will need to be evaluated per Route 1<sub>H</sub>.

Based on the assumptions listed in 4.3, the failure rates for the Bifold VBP, PPV, and HIPEX Series of High Flow Valves are listed in section 4.4.

These failure rates are valid for the useful lifetime of the product, see Appendix A.

The failure rates listed in this report are based on over 350 billion-unit operating hours of process industry field failure data. The failure rate predictions reflect realistic failures and include site specific failures due to human events for the specified Site Safety Index (SSI), see section 4.2.2.

A user of the Bifold VBP, PPV, and HIPEX Series of High Flow Valves can utilize these failure rates in a probabilistic model of a safety instrumented function (SIF) to determine suitability in part for safety instrumented system (SIS) usage in a particular safety integrity level (SIL).

<sup>1</sup> Type A element: “Non-Complex” element (using discrete components); for details see 7.4.4.1.2 of IEC 61508-2, ed2, 2010.



## Table of Contents

1	Purpose and Scope .....	5
2	Project Management .....	6
2.1	<i>exida</i> .....	6
2.2	Roles of the parties involved .....	6
2.3	Standards and literature used .....	6
2.4	Reference documents .....	8
2.4.1	Documentation provided by Bifold Fluidpower Ltd. ....	8
2.4.2	Documentation generated by <i>exida</i> .....	8
3	Product Description .....	9
4	Failure Modes, Effects, and Diagnostic Analysis .....	11
4.1	Failure categories description .....	11
4.2	Methodology – FMEDA, failure rates .....	11
4.2.1	FMEDA .....	11
4.2.2	Failure rates .....	12
4.3	Assumptions .....	12
4.4	Results .....	14
5	Using the FMEDA Results .....	16
5.1	PFD <sub>avg</sub> calculation Bifold VBP, PPV, and HIPEX Series of High Flow Valves .....	16
5.2	<i>exida</i> Route 2 <sub>H</sub> Criteria .....	16
6	Terms and Definitions .....	18
7	Status of the Document .....	20
7.1	Liability .....	20
7.2	Version History .....	20
7.3	Future enhancements .....	21
7.4	Release signatures .....	21
Appendix A	Lifetime of Critical Components .....	22
Appendix B	Proof Tests to Reveal Dangerous Undetected Faults .....	23
B.1	Suggested Proof Test .....	23
B.2	Proof Test Coverage .....	24
Appendix C	<i>exida</i> Environmental Profiles .....	25
Appendix D	Determining Safety Integrity Level .....	26
Appendix E	Site Safety Index .....	30
E.1	Site Safety Index Profiles .....	30

1



## 1 Purpose and Scope

This document shall describe the results of the hardware assessment in the form of the Failure Modes, Effects and Diagnostic Analysis carried out on the Bifold VBP, PPV, and HIPEX Series of High Flow Valves. From this, failure rates for each failure mode/category, useful life, and proof test coverage are determined.

The information in this report can be used to evaluate whether an element meets the average Probability of Failure on Demand ( $PFD_{avg}$ ) requirements and if applicable, the architectural constraints / minimum hardware fault tolerance requirements per IEC 61508 / IEC 61511.

A FMEDA is part of the effort needed to achieve full certification per IEC 61508 or other relevant functional safety standard.



## 2 Project Management

### 2.1 *exida*

*exida* is one of the world’s leading accredited Certification Bodies and knowledge companies specializing in automation system safety, availability, and cybersecurity with over 500-person years of cumulative experience in functional safety, alarm management, and cybersecurity. Founded by several of the world’s top reliability and safety experts from manufacturers, operators and assessment organizations, *exida* is a global corporation with offices around the world. *exida* offers training, coaching, project-oriented consulting services, safety engineering tools, detailed product assurance and ANSI accredited functional safety and cybersecurity certification. *exida* maintains a comprehensive failure rate and failure mode database on electronic and mechanical equipment and a comprehensive database on solutions to meet safety standards such as IEC 61508.

### 2.2 Roles of the parties involved

Bifold Fluidpower Ltd.                      Manufacturer of the Bifold VBP, PPV, and HIPEX Series of High Flow Valves

*exida*    Performed the hardware assessment

Bifold Fluidpower Ltd. contracted *exida* with the hardware assessment of the above-mentioned device.

### 2.3 Standards and literature used

The services delivered by *exida* were performed based on the following standards / literature.

[N1]	IEC 61508-2: ed2, 2010	Functional Safety of Electrical/Electronic/Programmable Electronic Safety-Related Systems
[N2]	Mechanical Component Reliability Handbook, 3rd Edition, 2012	<i>exida</i> LLC, Electrical & Mechanical Component Reliability Handbook, Third Edition, 2012, ISBN 978-1-934977-05-7
[N3]	Safety Equipment Reliability Handbook, 3rd Edition, 2007	<i>exida</i> L.L.C, Safety Equipment Reliability Handbook, Third Edition, 2007, ISBN 978-0-9727234-9-7
[N4]	Goble, W.M., 2010	Control Systems Safety Evaluation and Reliability, 3 <sup>rd</sup> edition, ISA, ISBN 97B-1-934394-80-9. Reference on FMEDA methods
[N5]	IEC 60654-1:1993-02, second edition	Industrial-process measurement and control equipment – Operating conditions – Part 1: Climatic condition
[N6]	O’Brien, C. , Stewart, L., & Bredemeyer, L., 2018	<i>exida</i> LLC., Final Elements in Safety Instrumented Systems IEC 61511 Compliant Systems and IEC 61508 Compliant Products, 2018, ISBN 978-1-934977-18-7
[N7]	Scaling the Three Barriers, Recorded Web Seminar, June 2013	<a href="http://www.exida.com/Webinars/Recordings/SIF-Verification-Scaling-the-Three-Barriers">http://www.exida.com/Webinars/Recordings/SIF-Verification-Scaling-the-Three-Barriers</a>



[N8]	Meeting Architecture Constraints in SIF Design, Recorded Web Seminar, March 2013	<a href="http://www.exida.com/Webinars/Recordings/Meeting-Architecture-Constraints-in-SIF-Design">http://www.exida.com/Webinars/Recordings/Meeting-Architecture-Constraints-in-SIF-Design</a>
[N9]	Random versus Systematic – Issues and Solutions, September 2016	<a href="http://www.exida.com/Resources/Whitepapers/random-versus-systematic-failures-issues-and-solutions">http://www.exida.com/Resources/Whitepapers/random-versus-systematic-failures-issues-and-solutions</a>
[N10]	Bukowski, J.V. and Chastain-Knight, D., April 2016	Assessing Safety Culture via the Site Safety Index™, Proceedings of the AIChE 12th Global Congress on Process Safety, GCPS2016, TX: Houston
[N11]	Bukowski, J.V. and Stewart, L.L., April 2016	Quantifying the Impacts of Human Factors on Functional Safety, Proceedings of the 12th Global Congress on Process Safety, AIChE 2016 Spring Meeting, NY: New York
[N12]	Criteria for the Application of IEC 61508:2010 Route 2H, December 2016	<i>exida</i> White Paper, Sellersville, PA www.exida.com
[N13]	Goble, W.M. and Brombacher, A.C., November 1999, Vol. 66, No. 2	Using a Failure Modes, Effects and Diagnostic Analysis (FMEDA) to Measure Diagnostic Coverage in Programmable Electronic Systems, Reliability Engineering and System Safety, Vol. 66, No. 2, November 1999.



## 2.4 Reference documents

### 2.4.1 Documentation provided by Bifold Fluidpower Ltd.

[D1]	0-GA0281_0; Rev 0	VBP-32-11-X-00 2" Volume Booster Valve Drawing
[D2]	0-GA0282_0; Rev 0	HIPEX-32-11-X-E-00 2" HIPEX Valve Drawing
[D3]	DP0049 - DC-QR02_3 - Design Sheet.pdf; Issue 0	2" Volume Booster and HIPEX Design Sheet
[D4]	volume booster Design File.pdf	Sample pages from the DP0049 Design File
[D5]	0-GA0320_3; Rev 3	PPV-32-P1-XX-32-NU-00-EEE-X-K54-01 Valve Drawing
[D6]	0-GA0322_3.pdf; Rev 3	PPV-32-P1-XX-32-NC-00-EEE-X-01 Valve Drawing
[D7]	DP0050 - DC-QR02_3 - Design Sheet.pdf; Issue 1	2" Pneumatic Pilot Valve Design Sheet
[D8]	PPV cat pg5.pdf; Draft	PPV Valve catalog page
[D9]	0-GA0916; Rev 2	PPV-16-16-32-NU-00-E-X-K54 Drawing
[D10]	0-GA0982; Rev 0; 27-Nov-20	PPV-08-08-32-NU-00-E-X-K54 Drawing
[D11]	0-GA0984; Rev 0; 27-Nov-20	PPV-08-08-32-NU-00-E-X-K54 Drawing

### 2.4.2 Documentation generated by *exida*

[R1]	Bifold VBP Q09-10-25r2 FMEDA R4.xlsx, 26-May-21	Failure Modes, Effects and Diagnostic Analysis, Bifold VBP, PPV, and HIPEX Series of High Flow Valves (internal document)
[R2]	BIF 091025 VBP FMEDA R001, V2R2, 2-Aug-23	FMEDA report, Bifold VBP, PPV, and HIPEX Series of High Flow Valves (this report)





### 3 Product Description

The VBP Series Volume Boosters convert a low volume pressure signal into a 1:1 ratio high volume output. It is specifically designed for both modulating and On - Off pilot pressure signals. When a low volume pilot pressure signal of 2 to 10 bar g is applied to the sensing port, the main valve assembly opens to allow high volume flow from the main inlet port to the outlet port. When the sensing assembly detects that the outlet pressure is equal to the pilot pressure, the main valve moves to the 'all ports blocked' rest position and will remain in this position until there is a change in the pilot pressure or outlet pressure. If the sensing head detects that the outlet is higher than the pilot pressure, the high flow exhaust opens to vent the excess pressure. If the sensing head detects that the outlet pressure is too low, the main valve opens to recharge the system to the correct 1:1 ratio pressure. For functional safety applications only the on-off mode of operation is considered.

The PPV Series Pneumatic Pilot Valves allow a low volume pressure signal to control a high volume output. When a low volume pilot pressure signal is applied to the pilot port, the main valve assembly opens to allow high volume flow from the main inlet port to the outlet port. These valves are generally used to control pneumatic flow to and from an actuator, or to dump large volumes of air.

The HIPEX Vavles is a quick exhaust valve designed for the purpose of providing a high volume exhaust capability. With pilot pressure applied to the pilot port the input port is blocked. When the pilot pressure is released the input port if connected to a high-volume capacity exhaust port. The input is also fed back against the pilot pressure. This enables the HIPEC Valve to also serve as a pressure relief valve. If the input pressure exceeds the pilot pressure the input port will open exhausting the input pressure until it is once again equal to the pilot pressure. The FMEDA only considered the quick exhaust function of the Bifold VBP, PPV, and HIPEX Series of High Flow Valves.

Table 3 lists the variants of the Bifold VBP, PPV, and HIPEX Series of High Flow Valves included in the FMEDA.

**Table 3 Variants**

Port Size	Description
1½ & 2 inch	Standard Volume Booster – VBP-24 and VBP-32 Series
½, 1, 1½ & 2 inch	Pneumatic Pilot Valve – PPV-08, -16, -24, and -32 Series
1½ & 2 inch	HIPEX Valve – HIPEX-24 and HIPEX-32 Series

Figure 1 shows a typical 2” port standard VBP Series Volume Booster, PPV Series Pneumatic Pilot Valve, and a HIPEX Series Valve.

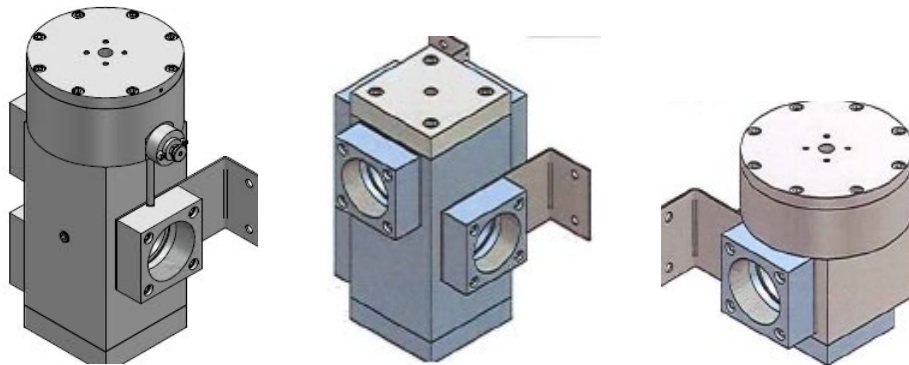

**Figure 1: Typical 2" VBP, PPV, and HIPEX Series Valves**

Table 4 gives an overview of the different versions that were considered in the FMEDA of the Bifold VBP, PPV, and HIPEX Series of High Flow Valves.

**Table 4 Version Overview**

<b>Model</b>	<b>Functional Safety Configuration</b>
Standard Volume Booster	De-Energize to trip
Pneumatic Pilot Valves – NU (Block After Bleed)	De-Energize to trip
HIPEX Valves	De-Energize to trip
Standard Volume Booster	Energize to trip
Pneumatic Pilot Valves – NU (Block After Bleed)	Energize to trip

Energize to trip applications failure rates do not take into account the loss of air supply to the booster.

The Bifold VBP, PPV, and HIPEX Series of High Flow Valves are classified as a Type A<sup>2</sup> devices according to IEC 61508, having a hardware fault tolerance of 0.

<sup>2</sup> Type A device: "Non-Complex" subsystem (using discrete elements); for details see 7.4.3.1.2 of IEC 61508-2 ed2, 2010.



## 4 Failure Modes, Effects, and Diagnostic Analysis

The Failure Modes, Effects, and Diagnostic Analysis was performed based on the documentation listed in section 2.4.1 and is documented in [R1].

### 4.1 Failure categories description

In order to judge the failure behavior of the Bifold VBP, PPV, and HIPEX Series of High Flow Valves, the following definitions for the failure of the device were considered.

Fail-Safe State:

De-Energize to Trip	State where booster or HIPEX is de-energized (pilot pressure vented) and actuator pressure is connected to exhaust.
Energize to Trip	State where pilot is energized and input pressure is connected to the actuator.
Fail Safe	Failure that causes the device to go to the defined fail-safe state without a demand from the process.
Fail Dangerous	Failure that does not respond to a demand from the process (i.e. being unable to go to the defined fail-safe state).
Fail Dangerous Undetected	Failure that is dangerous and that is not being diagnosed by automatic diagnostics, such as Partial Valve Stroke Testing.
Fail Dangerous Detected	Failure that is dangerous but is detected by automatic diagnostics, such as Partial Valve Stroke Testing.
No Effect	Failure of a component that is part of the safety function but that has no effect on the safety function.
External Leakage	Failure that causes process fluids, gas, hydraulic fluids or operating media to leak outside of the valve or actuator; External Leakage is not considered part of the safety function and therefore this failure rate is not included in any of the numbers. External leakage failure rates should be reviewed for secondary safety and environmental issues.

The failure categories listed above expand on the categories listed in IEC 61508 in order to provide a complete set of data needed for design optimization.

### 4.2 Methodology – FMEDA, failure rates

#### 4.2.1 FMEDA

A FMEDA (Failure Mode Effect and Diagnostic Analysis) is a failure rate prediction technique based on a study of design strength versus operational profile stress in each application. It combines design FMEA techniques with extensions to identify automatic diagnostic techniques and the failure modes relevant to safety instrumented system design. It is a technique recommended to generate failure rates for each failure mode category [N13].



## 4.2.2 Failure rates

The accuracy of any FMEDA analysis depends upon the component reliability data as input to the process. Component data from consumer, transportation, military or telephone applications could generate failure rate data unsuitable for the process industries. The component data used by *exida* in this FMEDA is from the Electrical and Mechanical Component Reliability Handbooks [N2] which were derived using over 350 billion-unit operational hours of process industry field failure data from multiple sources and failure data from various databases. The component failure rates are provided for each applicable operational profile and application, see Appendix C. The *exida* profile chosen for this FMEDA was Profile 3 (General Field Equipment) as this was judged to be the best fit for the product and application information submitted by Bifold Fluidpower Ltd.. It is expected that the actual number of field failures will be less than the number predicted by these failure rates.

Early life failures (infant mortality) are not included in the failure rate prediction as it is assumed that some level of commission testing is done. End of life failures are not included in the failure rate prediction as useful life is specified.

The failure rates are predicted for a Site Safety Index of SSI=2 ([N10] & [N11]) as this level of operation is common in the process industries. Failure rate predictions for other SSI levels are included in the exSILentia® tool from *exida*.

The user of these numbers is responsible for determining the failure rate applicability to any particular environment. *exida* Environmental Profiles listing expected stress levels can be found in Appendix C. Some industrial plant sites have high levels of stress. Under those conditions the failure rate data is adjusted to a higher value to account for the specific conditions of the plant. *exida* has detailed models available to make customized failure rate predictions (Contact *exida*).

Accurate plant specific data may be used to check validity of this failure rate data. If a user has data collected from a good proof test reporting system such as *exida* SILStat™ that indicates higher failure rates, the higher numbers shall be used.

## 4.3 Assumptions

The following assumptions have been made during the Failure Modes, Effects, and Diagnostic Analysis of the Bifold VBP, PPV, and HIPEX Series of High Flow Valves.

- The worst-case assumption of a series system is made. Therefore, only a single component failure will fail the entire Bifold VBP, PPV, and HIPEX Series of High Flow Valves, and propagation of failures is not relevant.
- Failure rates are constant for the useful life period.
- Any product component that cannot influence the safety function (feedback immune) is excluded. All components that are part of the safety function including those needed for normal operation are included in the analysis.
- The stress levels are specified in the *exida* Profile used for the analysis limited by the manufacturer's published ratings.
- Materials are compatible with the environmental and process conditions.
- Clean and dry operating air is used per ANSI/ISA-7.0.01-1996 Quality Standard for Instrument Air.



- The device is installed and operated per the manufacturer's instructions.
- Breakage or plugging of air inlet and outlet lines has not been included in the analysis.
- Failure rates for the double acting actuator options or ETT applications do not include failure of the air supply.
- Loss of the Air Pressure supply is not included in these failure rates.
- In order to claim diagnostic coverage for Partial Valve Stroke Testing it is automatically performed at a rate at least ten times faster than the Demand frequency.
- Partial Valve Stroke Testing of the Safety Instrumented Function provides a full cycle test of the solenoid/pilot valve. In cases where this is not true, another method must be used to perform a full Valve cycle during automated diagnostics in order to use the PVST numbers.
- Partial Valve Stroke Testing of the final element includes position detection from actuator top mounted position sensors, typical of quarter turn installations.



#### 4.4 Results

Using reliability data extracted from the *exida* Electrical and Mechanical Component Reliability Handbook the following failure rates resulted from the FMEDA analysis of the Bifold VBP, PPV, and HIPEX Series of High Flow Valves.

Table 5 lists the failure rates for the Bifold VBP, PPV, and HIPEX Series of High Flow Valves according to IEC 61508 with a Site Safety Index (SSI) of 2 (good site maintenance practices). See Appendix E for an explanation of SSI.

**Table 5 Failure Rates in FIT According to IEC 61508**

Model	Failure Category	$\lambda_{SD}$	$\lambda_{SU}^4$	$\lambda_{DD}$	$\lambda_{DU}$
Standard VBP-24 & -32	De-Energize to Trip	0	271	0	228
	Energize To Trip	0	73	0	427
	De-Energize to Trip -w/PVST	271	0	225	3
	Energize To Trip -w/PVST	73	0	421	6
HIPEX -24 & -32	De-Energize to Trip	0	156	0	135
	De-Energize to Trip -w/PVST	156	0	133	2
PPV-08 to -32 NU	De-Energize to Trip	0	167	0	98
	Energize To Trip	0	23	0	253
	De-Energize to Trip -w/PVST	167	0	97	1
	Energize To Trip -w/PVST	23	0	250	3

Where:

$\lambda_{SD}$  = Fail Safe Detected

$\lambda_{SU}$  = Fail Safe Undetected

$\lambda_{DD}$  = Fail Dangerous Detected

$\lambda_{DU}$  = Fail Dangerous Undetected<sup>7</sup>

# = No Effect Failures

E = External Leaks

These failure rates are valid for the useful lifetime of the product, see Appendix A.

According to IEC 61508-2 the architectural constraints of an element must be determined. This can be done by following the  $1_H$  approach according to 7.4.4.2 of IEC 61508-2 or the  $2_H$  approach according to 7.4.4.3 of IEC 61508-2, or the approach according to IEC 61511:2016 which is based on  $2_H$  (see Section 5.2).

The  $2_H$  approach involves assessment of the reliability data for the entire element according to 7.4.4.3.3 of IEC 61508.

<sup>4</sup> It is important to realize that the “Residual” failures are no longer included in the “Safe Undetected” failure category according to IEC 61508. Note that these failures on their own will not affect system reliability or safety, and should not be included in spurious trip calculations.



The failure rate data used for this analysis meets the *exida* criteria for Route 2<sub>H</sub> which is more stringent than IEC 61508. Therefore, the Bifold VBP, PPV, and HIPEX Series of High Flow Valves meets the hardware architectural constraints for up to SIL 2 at HFT=0 (or SIL 3 @ HFT=1) when the listed failure rates are used.

The architectural constraint type for the Bifold VBP, PPV, and HIPEX Series of High Flow Valves is A. The hardware fault tolerance of the device is 0. The SIS designer is responsible for meeting other requirements of applicable standards for any given SIL.



## 5 Using the FMEDA Results

The following section(s) describe how to apply the results of the FMEDA.

### 5.1 PFD<sub>avg</sub> calculation Bifold VBP, PPV, and HIPEX Series of High Flow Valves

Using the failure rate data displayed in section 4.4, and the failure rate data for the associated element devices, an average Probability of Failure on Demand (PFD<sub>avg</sub>) calculation can be performed for the entire final element.

Probability of Failure on Demand (PFD<sub>avg</sub>) calculation uses several parameters, many of which are determined by the particular application and the operational policies of each site. Some parameters are product specific and the responsibility of the manufacturer. Those manufacturer specific parameters are given in this third-party report.

Probability of Failure on Demand (PFD<sub>avg</sub>) calculation is the responsibility of the owner/operator of a process and is often delegated to the SIF designer. Product manufacturers can only provide a PFD<sub>avg</sub> by making many assumptions about the application and operational policies of a site which may be incorrect. Therefore, the use of pre-calculated PFD<sub>avg</sub> numbers requires complete knowledge of the assumptions and a match with the actual application and site.

Probability of Failure on Demand (PFD<sub>avg</sub>) calculation is best accomplished with *exida's* exSILentia tool. See Appendix D for a complete description of how to determine the Safety Integrity Level for the final element. The mission time used for the calculation depends on the PFD<sub>avg</sub> target and the useful life of the product. The failure rates for all the devices in the final element and the proof test coverage for the final element are required to perform the PFD<sub>avg</sub> calculation. The proof test coverage for the suggested proof test and the dangerous failure rate after proof test for the Bifold VBP, PPV, and HIPEX Series of High Flow Valves are listed in Table 8 and . This is combined with the dangerous failure rates after proof test for other devices in the final element to establish the proof test coverage for the final element.

When performing Partial Valve Stroke Testing at regular intervals, the Bifold VBP, PPV, and HIPEX Series of High Flow Valves contributes less to the overall PFD<sub>avg</sub> of the Safety Instrumented Function.

### 5.2 *exida* Route 2<sub>H</sub> Criteria

IEC 61508, ed2, 2010 describes the Route 2<sub>H</sub> alternative to Route 1<sub>H</sub> architectural constraints. The standard states:

"based on data collected in accordance with published standards (e.g., IEC 60300-3-2: or ISO 14224); and, be evaluated according to

- the amount of field feedback; and
- the exercise of **expert judgment**; and when needed
- the undertaking of specific tests,

in order to estimate the average and the uncertainty level (e.g., the 90% confidence interval or the probability distribution) of each reliability parameter (e.g., failure rate) used in the calculations."

*exida* has interpreted this to mean not just a simple 90% confidence level in the uncertainty analysis, but a high confidence level in the entire data collection process. As IEC 61508, ed2, 2010 does not give detailed criteria for Route 2<sub>H</sub>, *exida* has established the following:





1. field unit operational hours of 100,000,000 per each component; and
2. a device and all of its components have been installed in the field for one year or more; and
3. operational hours are counted only when the data collection process has been audited for correctness and completeness; and
4. failure definitions, especially "random" vs. "systematic" are checked by *exida*; and
5. every component used in an FMEDA meets the above criteria.

This set of requirements is chosen to assure high integrity failure data suitable for safety integrity verification.



## 6 Terms and Definitions

Automatic Diagnostics	Tests performed online internally by the device or, if specified, externally by another device without manual intervention.
Device	A device is something that is part of an element; but, cannot perform an element safety function on its own.
Dynamic Applications	The movement interval of the final element device is less than 200 hours. Movement may be accomplished by PVST, full stroke proof testing or a demand on the system.
Element	A collection of devices that perform an element safety function such as a final element consisting of a logic solver interface, actuator and valve.
<i>exida</i> criteria	A conservative approach to arriving at failure rates suitable for use in hardware evaluations utilizing the 2 <sub>H</sub> Route in IEC 61508-2.
Fault tolerance	Ability of a functional unit to continue to perform a required function in the presence of faults or errors (IEC 61508-4, 3.6.3).
FIT	Failure in Time ( $1 \times 10^{-9}$ failures per hour)
FMEDA	Failure Mode Effect and Diagnostic Analysis
HFT	Hardware Fault Tolerance
High demand Mode	Mode, where the demand interval for operation made on a safety-related system is less than twice the proof test interval.
Low demand mode	Mode, where the demand interval for operation made on a safety-related system is greater than twice the proof test interval.
PFD <sub>avg</sub>	Average Probability of Failure on Demand
PVST	Partial Valve Stroke Test - It is assumed that Partial Valve Stroke Testing, when performed, is automatically performed at least an order of magnitude more frequently than the proof test; therefore, the test can be assumed an automatic diagnostic. Because of the automatic diagnostic assumption, the Partial Valve Stroke Testing also has an impact on the Safe Failure Fraction.
Random Capability	The SIL limit imposed by the Architectural Constraints for each element.
Severe Service	Condition that exists when material through the valve has abrasive particles, as opposed to Clean Service where these particles are absent.
SFF	Safe Failure Fraction, summarizes the fraction of failures which lead to a safe state plus the fraction of failures which will be detected by automatic diagnostic measures and lead to a defined safety action.
SIF	Safety Instrumented Function
SIL	Safety Integrity Level



SIS	Safety Instrumented System – Implementation of one or more Safety Instrumented Functions. A SIS is composed of any combination of sensor(s), logic solver(s), and final element(s).
SSI	Site Safety Index (See Appendix E)
Static Applications	The movement interval of the final element device is greater than 200 hours. Movement may be accomplished by PVST, full stroke proof testing or a demand on the system.
Type A element	“Non-Complex” element (using discrete components); for details see 7.4.4.1.2 of IEC 61508-2
Type B element	“Complex” element (using complex components such as micro controllers or programmable logic); for details see 7.4.4.1.3 of IEC 61508-2



## 7 Status of the Document

### 7.1 Liability

*exida* prepares FMEDA reports based on methods advocated in International standards. Failure rates are obtained from *exida* compiled field failure data and a collection of industrial databases. *exida* accepts no liability whatsoever for the use of these numbers or for the correctness of the standards on which the general calculation methods are based.

Due to future potential changes in the standards, product design changes, best available information and best practices, the current FMEDA results presented in this report may not be fully consistent with results that would be presented for the identical model number product at some future time. As a leader in the functional safety market place, *exida* is actively involved in evolving best practices prior to official release of updated standards so that our reports effectively anticipate any known changes. In addition, most changes are anticipated to be incremental in nature and results reported within the previous three-year period should be sufficient for current usage without significant question.

Most products also tend to undergo incremental changes over time. If an *exida* FMEDA has not been updated within the last three years, contact the product vendor to verify the current validity of the results.

### 7.2 Version History

Contract Number	Report Number	Revision Notes
Q23/05-152	BIF 09/10-25 R002 V3, R3	Updated to latest template, 02Aug2023, REG
Q21/03-135	BIF 09/10-25 R002 V3, R2	Removed PPV NC (BBB) models, May 28, 2021
Q21/03-135	BIF 09/10-25 R002 V3, R1	Revised to include NU models PPV-08 and PPV-16; May 26, 2021
Q14/03-083	BIF 09/10-25 R002 V2, R1	Revised to 61508, 2010, Included 2H, S. Close, May 21, 2014
Q09/10-25	BIF 09/10-25 R002 V1, R1	Released to Bifold Fluidpower Ltd.
Q09/10-25	BIF 09/10-25 R002 V0, R2	Revised PPV descriptions March 21, 2011
Q09/10-25	BIF 09/10-25 R002 V0, R1	Initial Draft; March 1, 2011

Reviewer: Tobi Falomo, *exida*, 7/17/2023  
Status: Released, 7/17/2023



### 7.3 Future enhancements

At request of client.

### 7.4 Release signatures

A handwritten signature in black ink, appearing to read "Robert Gavin III".

---

Robert Gavin III, MSME, CFSE,  
Senior Safety Engineer

A handwritten signature in black ink, appearing to read "Oluwatobi Falomo".

---

Oluwatobi Falomo, Evaluating Assessor, Safety  
Engineer



## Appendix A Lifetime of Critical Components

According to section 7.4.9.5 of IEC 61508-2, a useful lifetime, based on experience, should be determined and used to replace equipment before the end of useful life.

Although a constant failure rate is assumed by the *exida* FMEDA prediction method (see section 4.2.2) this only applies provided that the useful lifetime<sup>9</sup> of components is not exceeded. Beyond their useful lifetime the result of the probabilistic calculation method is therefore meaningless, as the probability of failure significantly increases with time. The useful lifetime is highly dependent on the subsystem itself and its operating conditions.

This assumption of a constant failure rate is based on the bathtub curve. Therefore, it is obvious that the  $PFD_{avg}$  calculation is only valid for components that have this constant domain and that the validity of the calculation is limited to the useful lifetime of each component.

It is the responsibility of the end user to maintain and operate the Bifold VBP, PPV, and HIPEX Series of High Flow Valves per manufacturer's instructions. Furthermore, regular inspection should show that all components are clean and free from damage.

A major factor influencing the useful life is the air quality used.

Based on general field failure data a useful life period of approximately 10 to 15 years is expected for the Bifold VBP, PPV, and HIPEX Series of High Flow Valves.

For high demand mode applications, the useful useful lifetime of the Bifold VBP, PPV, and HIPEX Series of High Flow Valves is > 10,000 full scale cycles or 8 to 10 years, whichever results in the shortest lifetime.

When plant experience indicates a shorter useful lifetime than indicated in this appendix, the number based on plant experience should be used.

---

<sup>9</sup> Useful lifetime is a reliability engineering term that describes the operational time interval where the failure rate of a device is relatively constant. It is not a term which covers product obsolescence, warranty, or other commercial issues.



## Appendix B Proof Tests to Reveal Dangerous Undetected Faults

According to section 7.4.5.2 f) of IEC 61508-2, proof tests shall be undertaken to reveal dangerous faults which are undetected by automatic diagnostic tests. This means that it is necessary to specify how dangerous undetected faults which have been noted during the Failure Modes, Effects, and Diagnostic Analysis can be detected during proof testing.

### B.1 Suggested Proof Test

The suggested Proof Test consists of a full stroke of the associated device, see Table 7. Refer to the table in B.2 for the Proof Test Coverages.

**Table 6 Suggested Proof Test – Bifold VBP, PPV, and HIPEX Series of High Flow Valves**

Step	Action
1.	Bypass the safety function and take appropriate action to avoid a false trip.
2.	Interrupt or change the air supply/input to the Actuator to force the Actuator/Valve assembly to the Fail-Safe state and confirm that the Safe State was achieved and within the correct time. Note:-This tests for all failures that could prevent the functioning of the Control Valve as well as the rest of the final control element.
3.	Inspect the Actuator and Valve for any leaks, visible damage or contamination
4.	Re-store the original air supply/input to the Actuator and confirm that the normal operating state was achieved.
5.	Remove the bypass and otherwise restore normal operation.

For the test to be effective the movement of the Valve must be confirmed. To confirm the effectiveness of the test both the travel of the Valve and slew rate must be monitored and compared to expected results to validate the testing.



## B.2 Proof Test Coverage

The Proof Test Coverage for the various device configurations are given in Table 8 and .

**Table 7 Proof Test Results – Bifold VBP, PPV, and HIPEX Series of High Flow Valves – Static Application**

Model	Safety Function	Proof Test Coverage	
		No PVST	with PVST
Standard VBP-24 & 32	De-Energize to Trip	99%	23%
	Energize to Trip	99%	28%
HIPEX -24 & -32	De-Energize to Trip	99%	35%
PPV-08 & -32 NU	De-Energize to Trip	99%	0%
	Energize to Trip	99%	17%





## Appendix C *exida* Environmental Profiles

Table 8 *exida* Environmental Profiles

<i>exida</i> Profile	1	2	3	4	5	6
<b>Description (Electrical)</b>	Cabinet mounted/ Climate Controlled	Low Power Field Mounted no self-heating	General Field Mounted self-heating	Subsea	Offshore	N/A
<b>Description (Mechanical)</b>	Cabinet mounted/ Climate Controlled	General Field Mounted	General Field Mounted	Subsea	Offshore	Process Wetted
<b>IEC 60654-1 Profile</b>	B2	C3 also applicable for D1	C3 also applicable for D1	N/A	C3 also applicable for D1	N/A
<b>Average Ambient Temperature</b>	30 C	25 C	25 C	5 C	25 C	25 C
<b>Average Internal Temperature</b>	60 C	30 C	45 C	5 C	45 C	Process Fluid Temp.
<b>Daily Temperature Excursion (pk-pk)</b>	5 C	25 C	25 C	0 C	25 C	N/A
<b>Seasonal Temperature Excursion (winter average vs. summer average)</b>	5 C	40 C	40 C	2 C	40 C	N/A
<b>Exposed to Elements / Weather Conditions</b>	No	Yes	Yes	Yes	Yes	Yes
<b>Humidity<sup>12</sup></b>	0-95% Non-Condensing	0-100% Condensing	0-100% Condensing	0-100% Condensing	0-100% Condensing	N/A
<b>Shock<sup>13</sup></b>	10 g	15 g	15 g	15 g	15 g	N/A
<b>Vibration<sup>14</sup></b>	2 g	3 g	3 g	3 g	3 g	N/A
<b>Chemical Corrosion<sup>15</sup></b>	G2	G3	G3	G3	G3	Compatible Material
<b>Surge<sup>16</sup></b>						
Line-Line	0.5 kV	0.5 kV	0.5 kV	0.5 kV	0.5 kV	N/A
Line-Ground	1 kV	1 kV	1 kV	1 kV	1 kV	
<b>EMI Susceptibility<sup>17</sup></b>						
80 MHz to 1.4 GHz	10 V/m	10 V/m	10 V/m	10 V/m	10 V/m	N/A
1.4 GHz to 2.0 GHz	3 V/m	3 V/m	3 V/m	3 V/m	3 V/m	
2.0Ghz to 2.7 GHz	1 V/m	1 V/m	1 V/m	1 V/m	1 V/m	
<b>ESD (Air)<sup>18</sup></b>	6 kV	6 kV	6 kV	6 kV	6 kV	N/A

<sup>12</sup> Humidity rating per IEC 60068-2-3

<sup>13</sup> Shock rating per IEC 60068-2-27

<sup>14</sup> Vibration rating per IEC 60068-2-6

<sup>15</sup> Chemical Corrosion rating per ISA 71.04

<sup>16</sup> Surge rating per IEC 61000-4-5

<sup>17</sup> EMI Susceptibility rating per IEC 61000-4-3

<sup>18</sup> ESD (Air) rating per IEC 61000-4-2



## Appendix D Determining Safety Integrity Level

The information in this appendix is intended to provide the method of determining the Safety Integrity Level (SIL) of a Safety Instrumented Function (SIF). **The numbers used in the examples are not for the product described in this report.**

Three things must be checked when verifying that a given Safety Instrumented Function (SIF) design meets a Safety Integrity Level (SIL) [N4] and [N7].

These are:

- A. Systematic Capability or Prior Use Justification for each device meets the SIL level of the SIF;
- B. Architecture Constraints (minimum redundancy requirements) are met; and
- C. a  $PFD_{avg}$  calculation result is within the range of numbers given for the SIL level.

A. Systematic Capability (SC) is defined in IEC 61508:2010. The SC rating is a measure of design quality based upon the methods and techniques used to design and development a product. All devices in a SIF must have a SC rating equal or greater than the SIL level of the SIF. For example, a SIF is designed to meet SIL 3 with three pressure transmitters in a 2oo3 voting scheme. The transmitters have an SC2 rating. The design does not meet SIL 3. Alternatively, IEC 61511 allows the end user to perform a "Prior Use" justification. The end user evaluates the equipment to a given SIL level, documents the evaluation and takes responsibility for the justification.

B. Architecture constraints require certain minimum levels of redundancy. Different tables show different levels of redundancy for each SIL level. A table is chosen, and redundancy is incorporated into the design [N8].

C. Probability of Failure on Demand ( $PFD_{avg}$ ) calculation uses several parameters, many of which are determined by the particular application and the operational policies of each site. Some parameters are product specific and the responsibility of the manufacturer. Those manufacturer specific parameters are given in this third-party report.

A Probability of Failure on Demand ( $PFD_{avg}$ ) must be done based on a number of variables including:

1. Failure rates of each product in the design including failure modes and any diagnostic coverage from automatic diagnostics (an attribute of the product given by this FMEDA report);
2. Redundancy of devices including common cause failures (an attribute of the SIF design);
3. Proof Test Intervals (assignable by end user practices);
4. Mean Time to Restore (an attribute of end user practices);
5. Proof Test Effectiveness; (an attribute of the proof test method used by the end user with an example given by this report);
6. Mission Time (an attribute of end user practices);
7. Proof Testing with process online or shutdown (an attribute of end user practices);
8. Proof Test Duration (an attribute of end user practices); and
9. Operational/Maintenance Capability (an attribute of end user practices).

The product manufacturer is responsible for the first variable. Most manufacturers use the *exida* FMEDA technique which is based on over 350 billion hours of field failure data in the process industries to predict these failure rates as seen in this report. A system designer chooses the second variable. All other variables are the responsibility of the end user site. The exSILentia® SILVer™ software considers all these variables and provides an effective means to calculate  $PFD_{avg}$  for any given set of variables.

Simplified equations often account for only the first three variables. The equations published in IEC 61508-6, Annex B.3.2 [N1] cover only the first four variables. IEC 61508-6 is only an informative portion of the standard and as such gives only concepts, examples and guidance based on the idealistic assumptions stated. These assumptions often result in optimistic  $PFD_{avg}$  calculations and have indicated SIL levels higher than reality. Therefore, idealistic equations should not be used for actual SIF design verification.

All the variables listed above are important. As an example, consider a high-level protection SIF. The proposed design has a single SIL 3 certified level transmitter, a SIL 3 certified safety logic solver, and a single remote actuated valve consisting of a certified solenoid valve, certified scotch yoke actuator and a certified ball valve. Note that the numbers chosen are only an example and not the product described in this report.

Using exSILentia with the following variables selected to represent results from simplified equations:

- Mission Time = 5 years
- Proof Test Interval = 1 year for the sensor and final element, 5 years for the logic solver
- Proof Test Coverage = 100% (ideal and unrealistic but commonly assumed)
- Proof Test done with process offline

This results in a  $PFD_{avg}$  of 6.82E-03 which meets SIL 2 with a risk reduction factor of 147. The subsystem  $PFD_{avg}$  contributions are Sensor  $PFD_{avg} = 5.55E-04$ , Logic Solver  $PFD_{avg} = 9.55E-06$ , and Final Element  $PFD_{avg} = 6.26E-03$  (Figure 2).

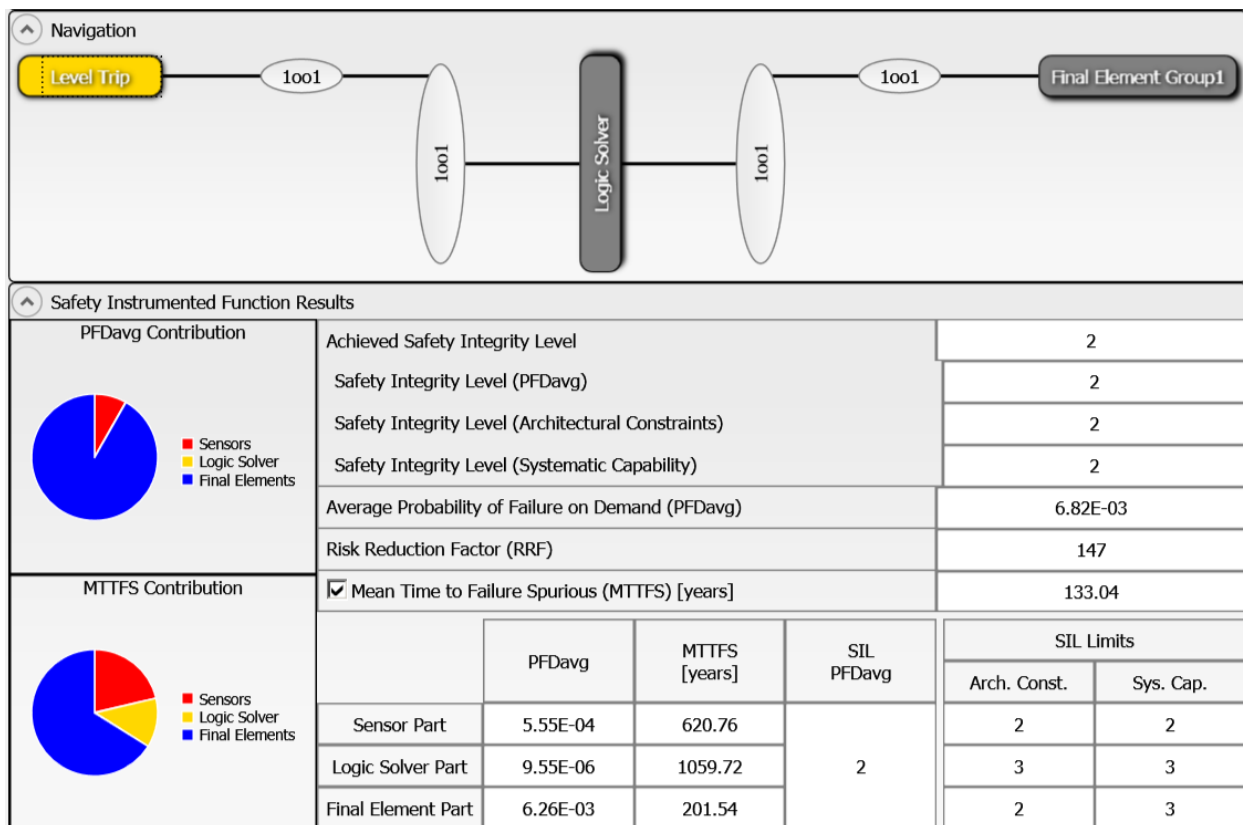
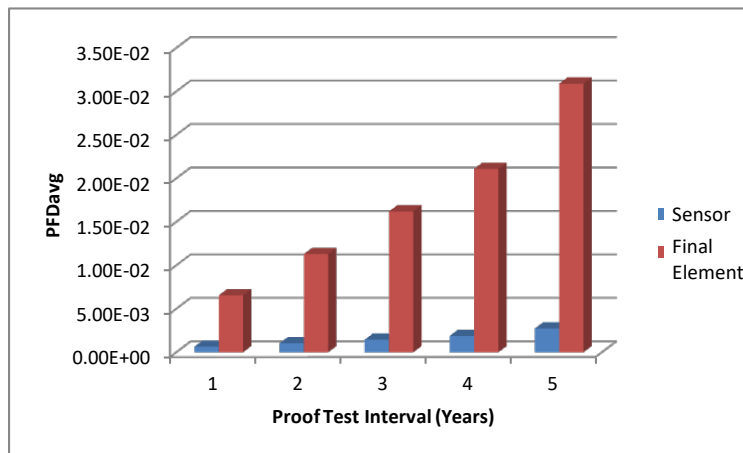

Figure 2: exSILentia results for idealistic variables

If the Proof Test Interval for the sensor and final element is increased in one-year increments, the results are shown in Figure 3.

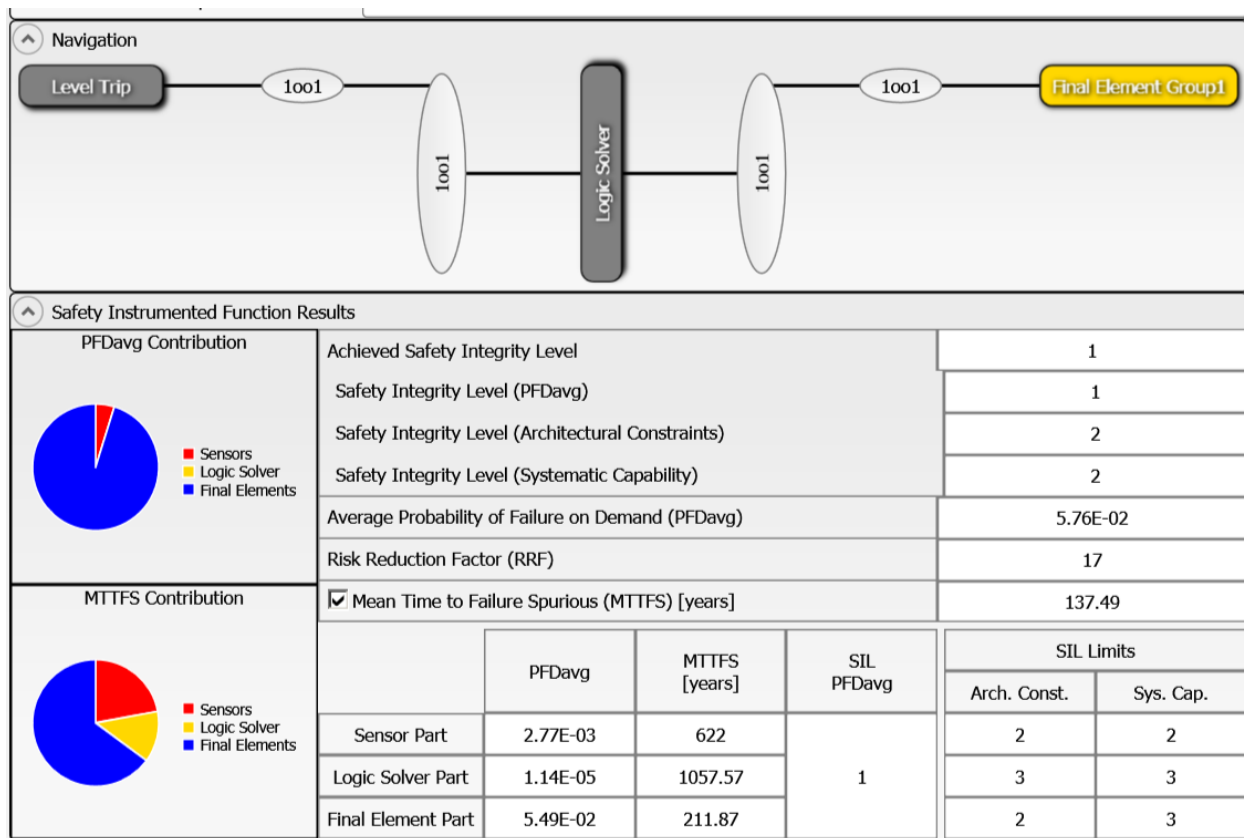

**Figure 3: PFD<sub>avg</sub> versus Proof Test Interval**

If a set of realistic variables for the same SIF are entered into the exSILentia software including:

- Mission Time = 25 years
- Proof Test Interval = 1 year for the sensor and final element, 5 years for the logic solver
- Proof Test Coverage = 90% for the sensor and 70% for the final element
- Proof Test Duration = 2 hours with process online.
- MTTR = 48 hours
- Maintenance Capability = Medium for sensor and final element, Good for logic solver

with all other variables remaining the same, the PFD<sub>avg</sub> for the SIF equals 5.76E-02 which barely meets SIL 1 with a risk reduction factor of 17. The subsystem PFD<sub>avg</sub> contributions are Sensor PFD<sub>avg</sub> = 2.77E-03, Logic Solver PFD<sub>avg</sub> = 1.14E-05, and Final Element PFD<sub>avg</sub> = 5.49E-02 (Figure 4).



**Figure 4: exSILentia results with realistic variables**

It is clear that  $PFD_{avg}$  results can change an entire SIL level or more when all critical variables are not used.



## Appendix E Site Safety Index

Numerous field failure studies have shown that the failure rate for a specific device (same Manufacturer and Model number) will vary from site to site. The Site Safety Index (SSI) was created to account for these failure rates differences as well as other variables. The information in this appendix is intended to provide an overview of the Site Safety Index (SSI) model used by *exida* to compensate for site variables including device failure rates.

### E.1 Site Safety Index Profiles

The SSI is a number from 0 – 4 which is an indication of the level of site activities and practices that contribute to the safety performance of SIF's on the site. Table 10 details the interpretation of each SSI level. Note that the levels mirror the levels of SIL assignment and that SSI 4 implies that all requirements of IEC 61508 and IEC 61511 are met at the site and therefore there is no degradation in safety performance due to any end-user activities or practices, i.e., that the product inherent safety performance is achieved.

Several factors have been identified thus far which impact the Site Safety Index (SSI). These include the quality of:

- Commission Test
- Safety Validation Test
- Proof Test Procedures
- Proof Test Documentation
- Failure Diagnostic and Repair Procedures
- Device Useful Life Tracking and Replacement Process
- SIS Modification Procedures
- SIS Decommissioning Procedures
- and others

**Table 9** *exida* Site Safety Index Profiles

Level	Description
SSI 4	Perfect - Repairs are always correctly performed, Testing is always done correctly and on schedule, equipment is always replaced before end of useful life, equipment is always selected according to the specified environmental limits and process compatible materials. Electrical power supplies are clean of transients and isolated, pneumatic supplies and hydraulic fluids are always kept clean, etc. <b>Note:</b> This level is generally considered not possible but retained in the model for comparison purposes.
SSI 3	Almost perfect - Repairs are correctly performed, Testing is done correctly and on schedule, equipment is normally selected based on the specified environmental limits and a good analysis of the process chemistry and compatible materials. Electrical power supplies are normally clean of transients and isolated, pneumatic supplies and hydraulic fluids are mostly kept clean, etc. Equipment is replaced before end of useful life, etc.
SSI 2	Good - Repairs are usually correctly performed, Testing is done correctly and mostly on schedule, most equipment is replaced before end of useful life, etc.
SSI 1	Medium – Many repairs are correctly performed, Testing is done and mostly on schedule, some equipment is replaced before end of useful life, etc.
SSI 0	None - Repairs are not always done, Testing is not done, equipment is not replaced until failure, etc.

