

# RCEL

## Built-in SUPER CAPACITOR

# Manual



### Standard Specification

Enclosure	Watertight Ingress Protection 67 Nema 4 and 6
Ambient Temperature	-20°C to +70°C
Power Supply	DC24, DC48, AC90V ~ 260V 50/60Hz
Torque Switches	2 Open / Close (Except RCEL006, RCEL009)
Limit Switches	2 Open / Close, 250VAC 15A Rating
Stall Protection	Built - in Thermal Protection
Travel Angle	90±5°C
Indicator	Continuous Position Indicator
Manual Override	Hand / Auto Decutching Mechanism
Self Locking	Provided by means of Worm Gearing
Mechanical Stops	External Adjustable Screws
Space Heater	20W
Cable Entries	2-PF 3/4" (Option: M20xPitch1.5, NPT 3/4")
Lubrication	Shell Gadus S2 V220 2
Material	Aluminum
Surface Treatment	Anodizing
External Coating	Polyester(TGIC-Free)

### Built in Super Capacitor Specification

Power Supply	DC24, DC48, AC90V ~ 260V 50/60Hz	Number of Emergency Operating	1travel (Open to Close or Close to Open)			
Charging Voltage	26.5V	Charging Current	DC24,48V	8.4A		
Charging Time	RCEL006~019		3 min 30 sec	RCEL006~019	115V	1.1A
	RCEL028		2 min	RCEL028	230V	0.45A
Weight	0.7 kg		RCEL028	DC24,48V	8.4A	
				115V	2.2A	
				230V	1.1A	



Charge up a super capacitor before use. If the capacitor is not fully charged, emergency operating is not available.

### Performance

Model	Output Torque		Operating Time(90°) (Sec)	Rated Current (A)				Motor Class (W)	Number of Handle Turns	Weight
	Kg.m	N.m		50Hz / 60Hz	DC24V	DC48V	115V			
RCEL006	6	58	15	2.5	1.3	0.6	0.3	DC Motor	8.5	kg
RCEL009	9	88	17	3.5	1.8	0.8	0.37	15	8.5	13.5
RCEL015	15	147	17	4.5	2.4	1.0	0.43	25	10	16
RCEL019	19	186	19	4.5	2.4	1.0	0.43	40	10	16
RCEL028	28	274	22	7.0	3.6	2.25	1.13	40	12.5	18.5



## CAUTION



Turn of **ALL Power** before opening the terminal cover of the actuator.

Before use, verify the nameplate information to make sure the actuator has all the correct contents. (model number, torque, power voltage)

Please be sure to completely read and review the actuator manual prior to operation.

Use the grounding lugs provided inside and outside the actuator to properly ground the actuator.

Actuator must be charged before use as super capacitors could be discharged. (Charging time: 3 and a half minutes).

Charge Lamp flickers during charging and it goes off when charging ends.

Inside and outside earth terminals should be grounded properly.

### Board Specification

#### AC Type

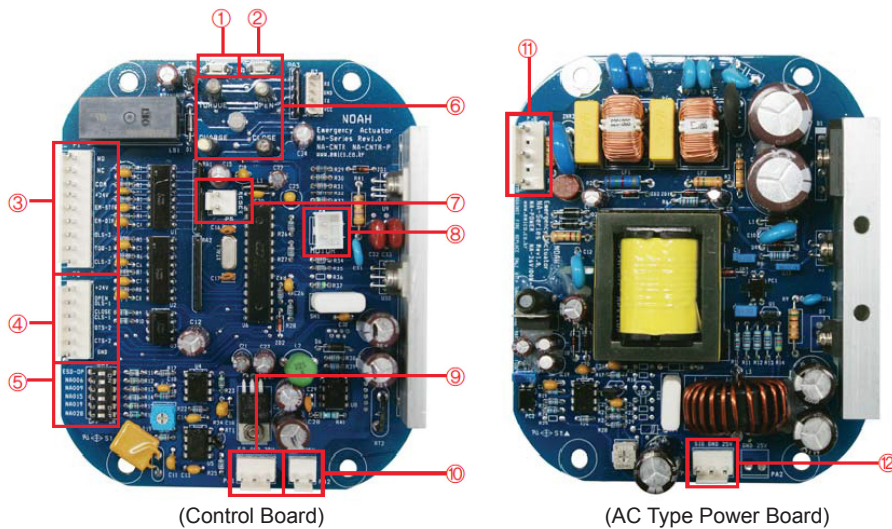

#### DC Type

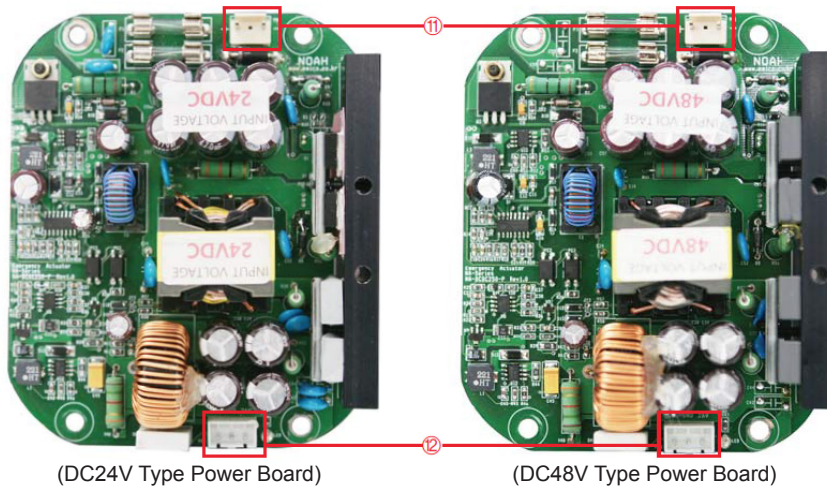

No.	Name	No.	Name
1.	Close Button	7.	Reset Connector
2.	Open Button	8.	Motor Connector
3.	Esd Connector	9.	Power & Control Board Connector
4.	Control Connector	10.	Super Capacitor Connector
5.	DIP Switch	11.	Power Connector
6.	LED Lamps	12.	Power & Control Board Connector

### Close Button - Open Button



Close: Close operate as While pressing the button

Open: Open operate as While pressing the button

### DIP Switch

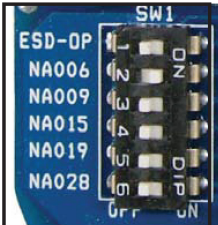

ESD - OP ( Default: Off )

▶ When ESD - OP dip switch is OFF: The actuator operates depending on fail action setting.

▶ When ESD - OP dip switch is ON:

In Case of sudden power failure, the actuator continues to run to the position it has been proceeding regardless of fail action position.

(If the main power is off while the actuator is stopped, it will be operated to fail action position)

ESD – OP dip switch	Operation by the main power		Fail action
	Open running	Stop	
ON	Open running	Stop	Open running
	Open running	Stop	Close running
OFF	Open running	Stop	Close running
	Open running	Stop	Close running

(If the Fail action is set to Close direction)

One dip switch should be turned on in accordance with its actuator model among dip switches for RCEL006-RCEL028. By sensing motors value of current, the actuator and the application can be stopped to protect them from over torque. It is electrical torque sensing system.

### Lamp

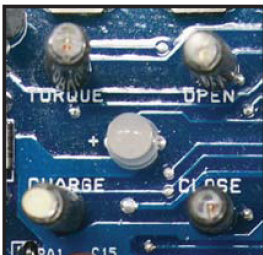

Torque Lamp	Actuator Over Torque
Open Lamp	Actuator Full Open
Close Lamp	Actuator Full close
Charge Lamp	Charge Lamp goes off when fully charged.

Name	LED				Remark
	Open	Close	Torque	Charge	
Power ON	Flickering	Flickering	Flickering	Flickering	3 times
Full Open	On				
Open Running	Flickering				
Full Close		On			
Close Running		Flickering			
Mechanical Over Torque			On		
Electrical Over Torque			Flickering		
Charge ( 23V ↓ )				Flickering	
Charge ( 23V ↑ )				Off	
ESD (Open)	Flickering and then off				
ESD (Close)		Flickering and then off			
Disconnected	Flickering	Flickering			Disconnected to the board

## Reset Connector

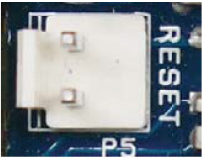

In case of Over Torque, reboot the control board.  
(\* It is not necessary to reboot the main board's power in this case.)

## Dimensions

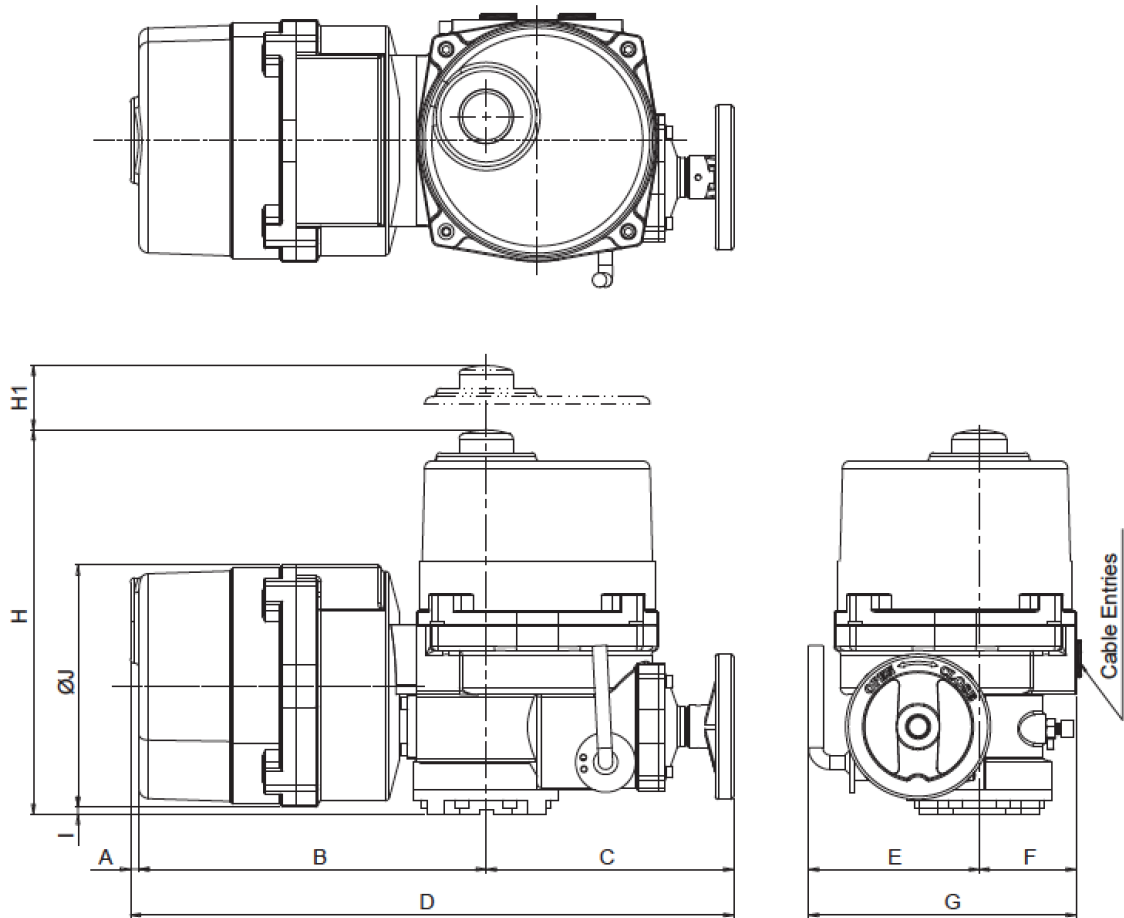

	A	B	C	D	E	F	G	H	H1	I	ØJ	Base ISO5211	Cable Entries
RCEL006	6	244	174	424	120	68	188	270	108	5	170	F07 Ø70 / 4-M8 DP12 MAX Ø22	2-PF3/4" (Option: M20XPitch1.5, NPT3/4")
RCEL009													
RCEL015	6	265	184	455	139	85	224	274	108	5	170	F07 Ø70 / 4-M8 DP12	2-PF3/4" (Option: M20XPitch1.5, NPT3/4")
RCEL019												F10 Ø102 / 4-M10 DP15 MAX Ø22	

## Wiring

### RCEL006-009 SCP, ALS

CLS : CLOSE LIMIT SWITCH (250VAC 16A)  
 OLS : OPEN LIMIT SWITCH (250VAC 16A)  
 ACLS : AUX. CLOSE LIMIT SWITCH (250VAC 16A)  
 AOLS : AUX. OPEN LIMIT SWITCH (250VAC 16A)  
 TP : THERMAL PROTECTOR (250VAC 15A)

	CLOSE	OPEN
CLS 1-2		
CLS 1-3		
OLS 1-2		
OLS 1-3		
ACLS 1-2		
ACLS 1-3		
AOLS 1-2		
AOLS 1-3		

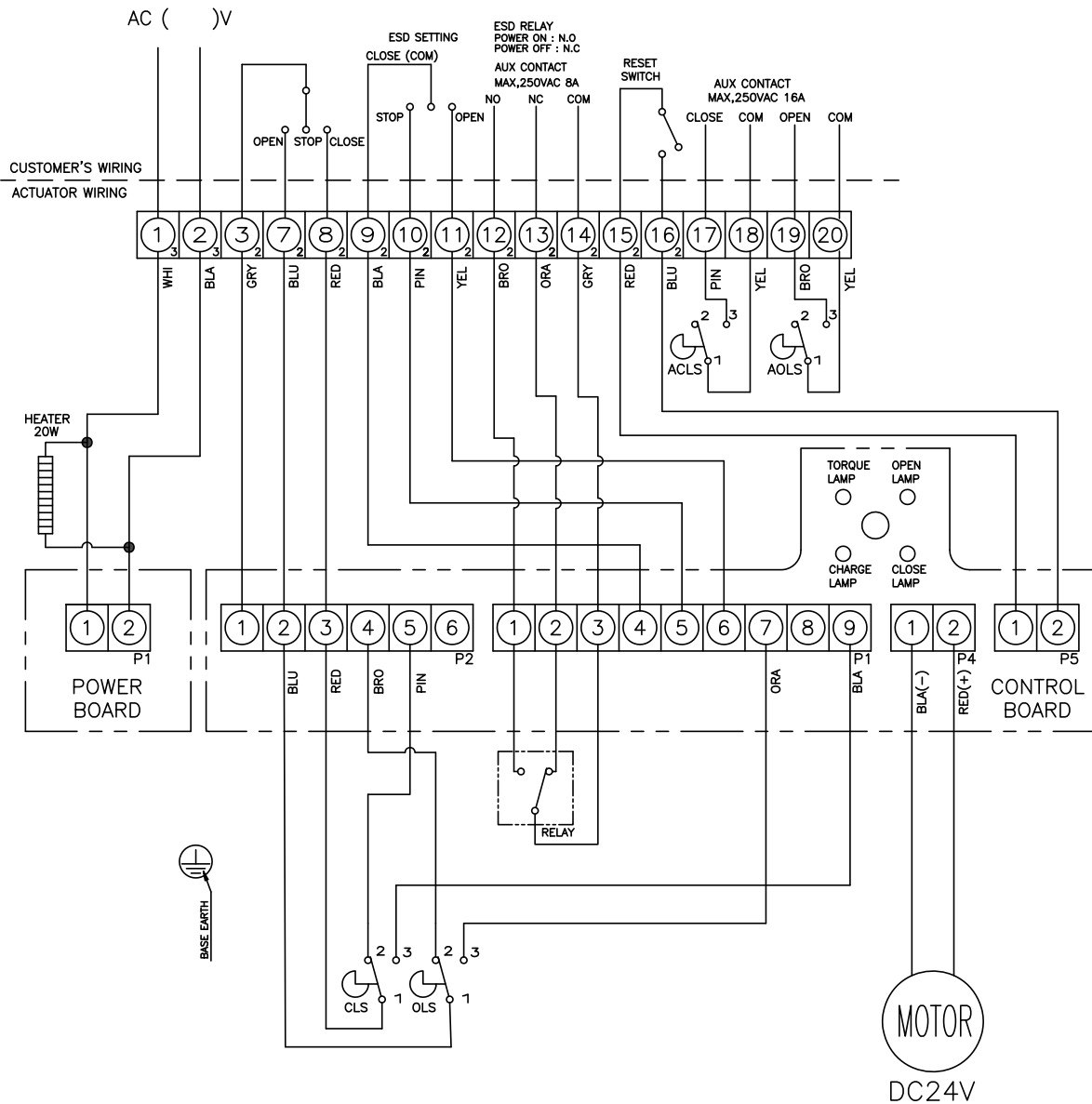

NU-126S0-A

**RCEL015-028 SCP, ALS**

- CLS : CLOSE LIMIT SWITCH (250VAC 16A)
- OLS : OPEN LIMIT SWITCH (250VAC 16A)
- CTS : CLOSE TORQUE SWITCH (250VAC 16A)
- OTS : OPEN TORQUE SWITCH (250VAC 16A)
- ACLS : AUX. CLOSE LIMIT SWITCH (250VAC 16A)
- AOLS : AUX. OPEN LIMIT SWITCH (250VAC 16A)
- TP : THERMAL PROTECTOR (250VAC 15A)

	CLOSE	OPEN
CLS 1-2		
CLS 1-3		
OLS 1-2		
OLS 1-3		
ACLS 1-2		
ACLS 1-3		
AOLS 1-2		
AOLS 1-3		
CTS 1-3	* CLOSING TORQUE SWITCH INTERRUPTS CONTROL IF MECHANICAL OVERLOAD OCCURS DURING CLOSING CYCLE	
OTS 1-3	* OPENING TORQUE SWITCH INTERRUPTS CONTROL IF MACHANICAL OVERLOAD OCCURS DURING OPENING CYCLE	

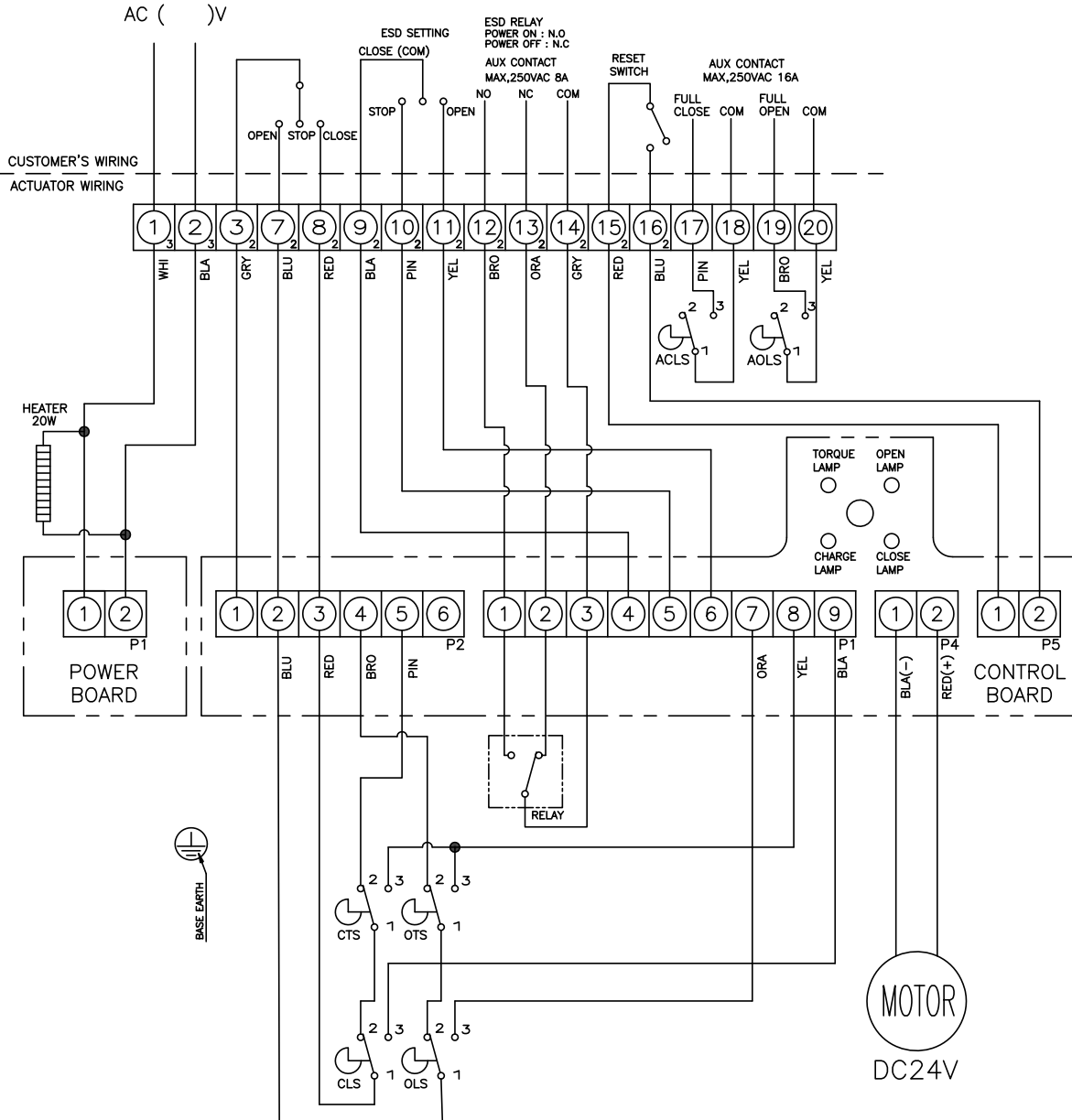

NS-126S0-A

**RCEL006-009 SCP, ALS**

CLS : CLOSE LIMIT SWITCH (250VAC 16A)  
 OLS : OPEN LIMIT SWITCH (250VAC 16A)  
 ACLS : AUX. CLOSE LIMIT SWITCH (250VAC 16A)  
 AOLS : AUX. OPEN LIMIT SWITCH (250VAC 16A)

	CLOSE	OPEN
CLS 1-2		
CLS 1-3		
OLS 1-2		
OLS 1-3		
ACLS 1-2		
ACLS 1-3		
AOLS 1-2		
AOLS 1-3		

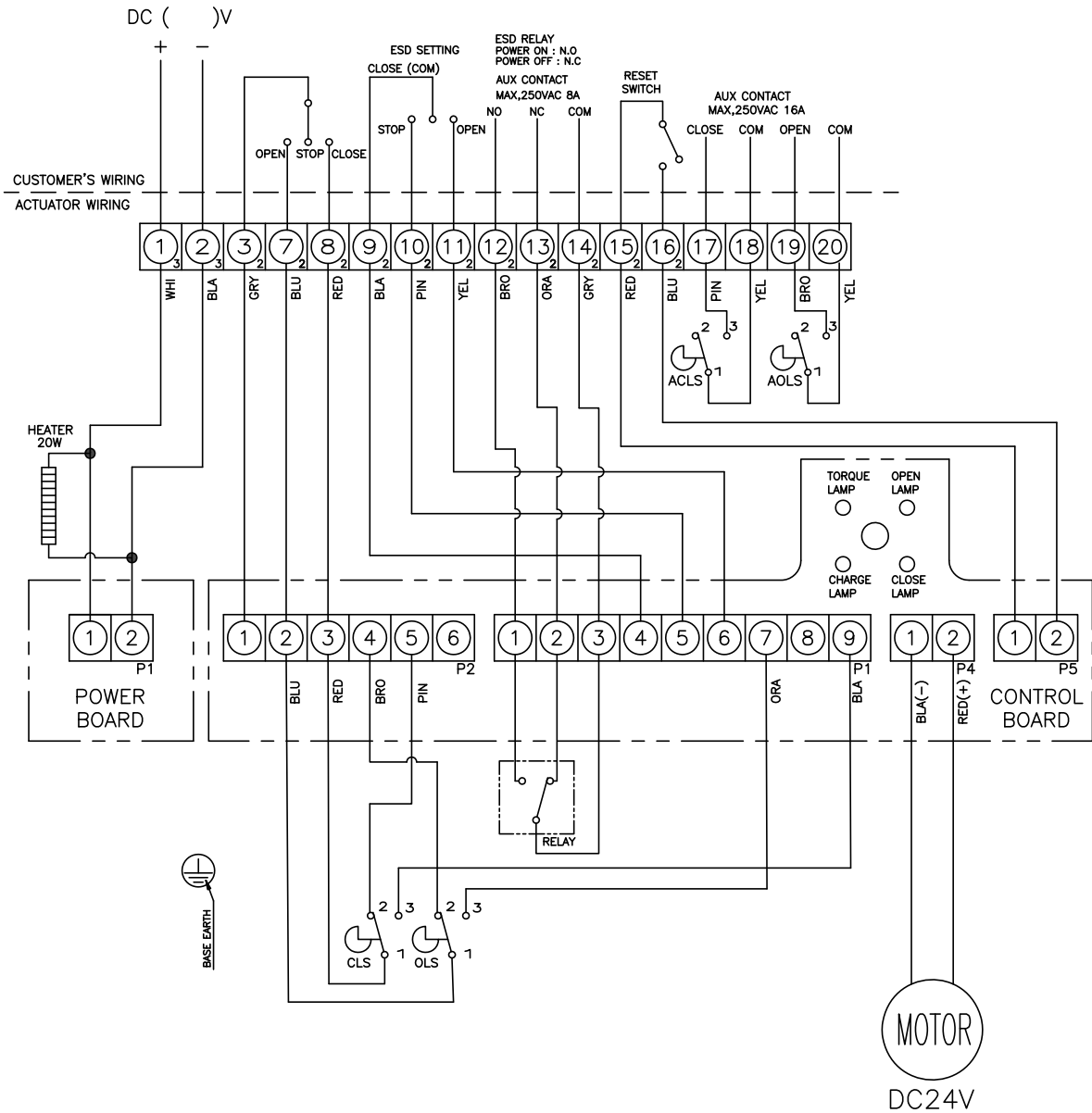

**RCEL015-028 SCP, ALS**

- CLS : CLOSE LIMIT SWITCH (250VAC 16A)
- OLS : OPEN LIMIT SWITCH (250VAC 16A)
- CTS : CLOSE TORQUE SWITCH (250VAC 16A)
- OTS : OPEN TORQUE SWITCH (250VAC 16A)
- ACLS : AUX. CLOSE LIMIT SWITCH (250VAC 16A)
- AOLS : AUX. OPEN LIMIT SWITCH (250VAC 16A)
- TP : THERMAL PROTECTOR (250VAC 15A)

	CLOSE	OPEN
CLS 1-2		
CLS 1-3		
OLS 1-2		
OLS 1-3		
ACLS 1-2		
ACLS 1-3		
AOLS 1-2		
AOLS 1-3		
CTS 1-3	* CLOSING TORQUE SWITCH INTERRUPTS CONTROL IF MECHANICAL OVERLOAD OCCURS DURING CLOSING CYCLE	
OTS 1-3	* OPENING TORQUE SWITCH INTERRUPTS CONTROL IF MECHANICAL OVERLOAD OCCURS DURING OPENING CYCLE	

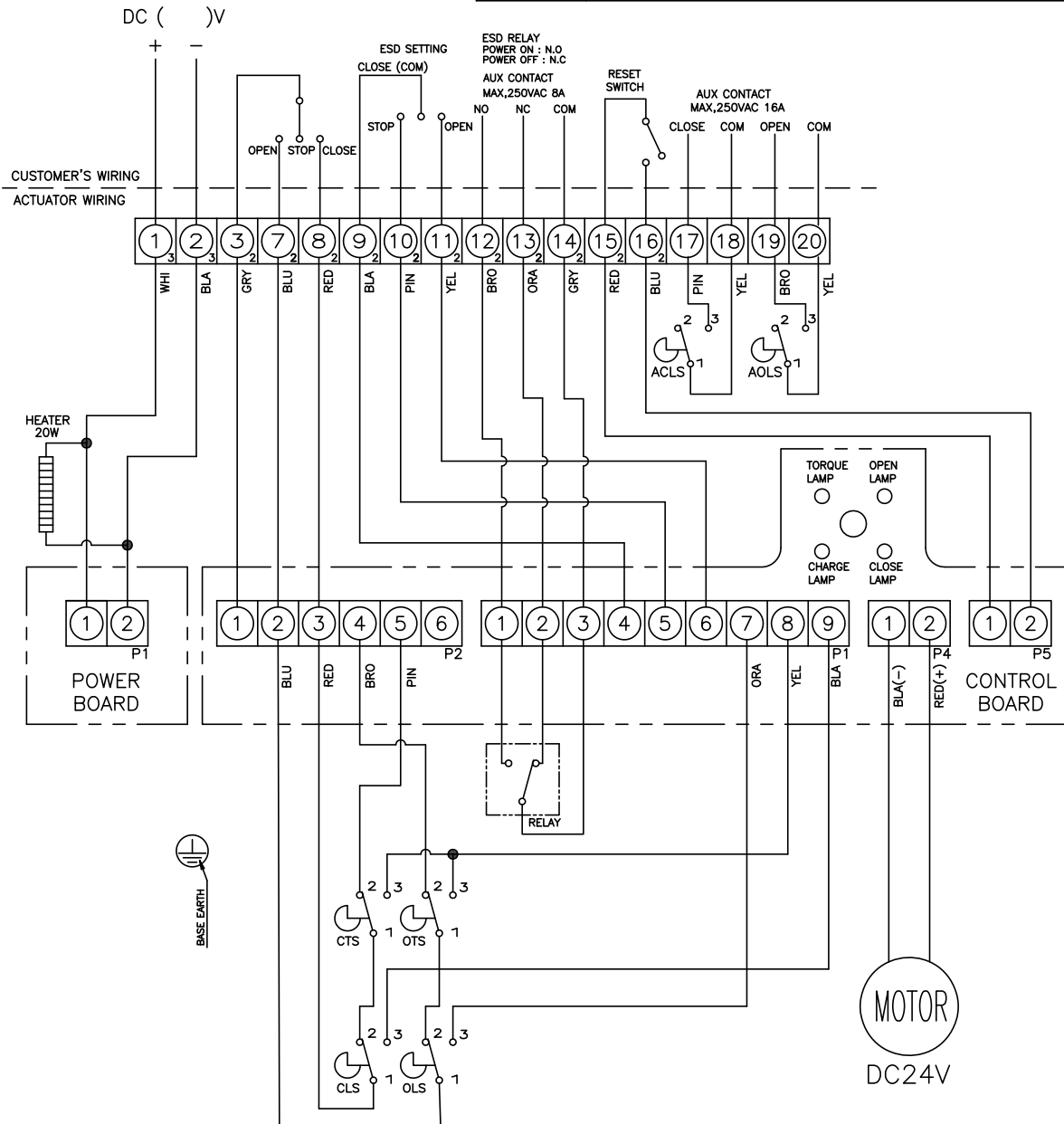

**NS-826S0-A**

