

rotork®

Keeping the World Flowing
for Future Generations

PAX1 Motor Set Pressure Regulator

User Manual



A rotork® Brand
FAIRCHILD
precision pneumatic & motion control

Contents

Section	Page
1. Overview	2
2. General Information	3
3. Installation	4
4. Electrical Connections, DC Power	6
5. Electrical Connections, AC Power	8
6. User Interface	10
7. Commissioning	11
8. Installation Dimensions	14
9. Specifications	21
10. Maintenance	22
11. PAX1 Actuator & Pressure Regulator Assembly	23

1. Overview

The PAX1 Motor Set Pressure Regulator is a flexible linear actuator coupled to Fairchild precision pressure regulators and capable of controlling pressure ranges of 0-0.5 psig to 0-3000 psig all housed in a flameproof enclosure. The unit's failure mode is inherently fail freeze as the actuator will maintain its position upon loss of electrical power.

Power input options include 12-24 VDC or universal AC input 95-250 VAC 47-63 Hz.

The PAX1 can be actuated open loop using two optically isolated switch closure inputs (Up and Down) to change the pressure regulator's setpoint. The PAX1 will continue to change the pressure regulator's setpoint in response to the activated input until either of the adjustable range limits are reached.

The PAX1 has an isolated 4-20 mA control input to proportionally control the pressure regulator's setpoint. In analogue control mode, the unit is fail freeze upon loss of the control signal.

The actuator features UP (EXTEND) and DOWN (RETRACT) push buttons under the cover to facilitate commissioning and to permit local control of the pressure regulator's setpoint. There is an 8 mm (⁵/₁₆") female hex motor drive interface under the cover to allow manual setpoint adjustment in the case of loss of electrical power.

⚠ WARNING: The cover must not be removed in the presence of a hazardous classified combustible atmosphere when power is present. Multiple power sources are possible including those operating the analogue inputs, pulse inputs, alarm relays and feedback circuits.

The actuator includes two fully adjustable 1A, 250 VAC SPDT alarm relays (one High and one Low) providing alarm function when the pressure regulator output pressure reaches critical values. The relays are magnetically latched so the alarm switch states are maintained when the power is disconnected. This allows accurate alarm function on systems that remove power from the actuator between adjustments to conserve power as is typically done in solar powered installations.

The PAX1 offers an optional optically isolated electronic 4-20 mA feedback output. This feedback feature is functional for both the pulse control and analogue control configurations. The unit must be powered to facilitate the feedback output function.

The PAX1 can also be controlled via Modbus RTU digital communications over an optional optically isolated RS-485 network. The Modbus communications include a full featured command set allowing control, monitoring, commissioning and diagnostics capability over the digital communication.

2. General Information

The PAX1 Motor Set Pressure Regulator described in this document has been designed and manufactured with state of the art technology. All components are subject to stringent quality and environmental requirements during manufacture. Our quality systems are certified ISO 9001.

This user's manual contains important information that enables a competent user to install, operate and maintain this Motor Set Pressure Regulator. The installation, operation and maintenance of this unit in a hazardous area must be carried out by an appropriately trained and qualified person and in accordance with all relevant codes of practice for the particular Hazardous Area Classification.

WARNING

Installation must be carried out by qualified personnel in accordance with all national and local codes and ordinances.

Shock Hazard. Multiple power sources possible. Disconnect all power sources before servicing. Serious injury or death could result.

Read and understand all instructions carefully before starting installation. Save this document for future use. Failure to read and understand these instructions could result in improper operation of the device leading to equipment damage, serious injury, or death.

Hazardous Area Ratings

FM Explosionproof

Class I, Division 1, Groups A,B,C,D, T6...T5
Class II, III Division 1, Groups E,F,G, T6...T5
Class 1, Zone 1, AEx db IIC, T6...T5 Gb
Zone 21, AEx tb IIIC T85°C...100°C Db
T6[T85°C]: Ta = -40°C to +65°C
T5[T100°C]: Ta = -40°C to +70°C
Type 4X/6P, IP66/68

CSA

Class I, Division 1, Groups B,C,D, T6...T5
Class II, III Division 1, Groups E,F,G, T6...T5
Ex db IIC, T6...T5 Gb
Ex tb IIIC T85°C...T100°C Db
T6[T85°C]: Ta = -40°C to +65°C
T5[100°C]: Ta = -40°C to +70°C
Type 4X/6P, IP66, IP68

CCC/NEPSI

Ex db IIC T6/T5 Gb
Ex tb IIIC T85°C/T100°C Db
T6/ T85°C : -40°C to +65°C
T5/ T100°C : -40°C to +70°C
IP66/IP68

ATEX/IECEx/UKEX

Ex db IIC T6/T5 Gb
Ex tb IIIC T85°C/T100°C Db
 II 2 GD
T6[T85°C]: Ta -40°C to +65°C,
T5[T100°C] Ta -40°C to +70°C
IP66, IP68

FM Hazardous Area Conditions of use

- Hazardous locations wiring must comply with ANSI/NFPA 70 (NEC®).
- Wiring must be rated 110 °C or higher.
- Explosionproof certified seals are required within 18" for Groups A, B, C and D installations or within 2" for Group IIC installations.
- The PAX1 Actuator includes flame path joints. Consult the factory if repairs of the flame path joints are necessary.
- Suitably rated conduit seals are required to prevent water ingress in NEMA 4X, IP66 applications or IP68 and NEMA 6P submersible applications. The seals must be rated for the environment of use such as hazardous area, ingress protection and temperature.

CSA Hazardous Area Conditions of use

- Hazardous locations wiring must comply with CSA: CEC Part 1.
- Explosionproof certified seals are required within 18" for both Zones and Division installations.
- The PAX1 Actuator includes flame path joints. Consult the factory if repairs of the flame path joints are necessary.
- Suitably rated conduit seals are required to prevent water ingress in NEMA 4X, IP66 applications or IP68 and NEMA 6P submersible applications. The seals must be rated for the environment of use such as hazardous area, ingress protection and temperature.
- **CAUTION:** USE SUPPLY WIRES SUITABLE FOR AT LEAST 90 °C.
- **ATTENTION:** EMPLOYER DES FILS D'ALIMENTATION QUI CONVENNENT POUR AU MOINS 90 °C.
- WIRING TO BE CONNECTED TO A CLASS 2 CIRCUIT ONLY.
- *RACCORDER UNIQUEMENT À UN CIRCUIT DE CLASSE 2".*
- **CAUTION:** KEEP COVER TIGHT WHILE CIRCUITS ARE ALIVE.
- **ATTENTION:** *GARDER LE COUVERCLE BIEN FERMÉ TANT QUE LE CIRCUITS SONT SOUS TENSION.*
- **WARNING:** POTENTIAL ELECTROSTATIC CHARGING HAZARD – SEE INSTRUCTIONS.
- **AVERTISSEMENT:** *DANGER POTENTIEL DE CHARGE ELECTROSTATIQUE – VOIR LES INSTRUCTIONS.*
- A SEAL SHALL BE INSTALLED WITHIN 18 in (45 cm) OF THE ENCLOSURE.
- *UN SCELLEMENT DOIT ÊTRE INSTALLÉ À MOINS DE 45 cm (18 in) DU BOÎTER".*

2. General Information *continued*

Hazardous Area (Classified) Conditions of use

- Under certain extreme circumstances, the non-metallic parts incorporated into the enclosure of this equipment may generate an ignition-capable level of electrostatic charge. Therefore the equipment shall not be installed in a location where the external conditions are conducive to the build-up of electrostatic charge on such surfaces. In addition, the equipment shall only be cleaned with a damp cloth.
- Contact the manufacturer if information of flameproof joints is needed.

3. Installation

The PAX1 can be mounted in any position without affecting its operation. It can be mounted to a flat surface using the mounting holes on the actuator. An optional mounting bracket is also available. For details, see "PAX1 Exterior Dimensions".

Pressure Regulator Piping

Clean all pipelines to remove dirt and scale before installation. Apply a minimum amount of pipe compound to the male threads of the fitting only. Do not use Teflon tape as a sealant. Start with the third thread back and work away from the end of the fitting to avoid the possibility of contaminating the regulator. Install the regulator in the air line. The inlet and outlet connections are labeled on the regulator body under the ports. Tighten connections securely.

NOTES: Oil free air must be applied to the regulator. Use a filter to remove dirt and entrained liquid in the air line ahead of the pressure regulator. If an airline lubricator is used, it **MUST** be located downstream of the pressure regulator or performance will be affected.

Installation below ground level

Pressure Regulator Vent: For units that are installed below ground and in areas where the unit may be under water due to flooding, the pressure regulator vent should be piped to an area where the outlet of the vent pipe is located at an elevation above any possible flooding. Water entering the bonnet vent will cause an increase in the outlet pressure in direct relation to the depth of the water above the vent. This can cause a significant increase in outlet pressure especially in low pressure systems and may cause dangerous system overpressure conditions.

Conduit Seal: The PAX1 is rated for limited submerged operation but the user is responsible for ensuring water cannot enter the PAX1 enclosure through the conduit connection and conduit port. Ensure the conduit installation is watertight at elevations that may be submerged below water. Where conduit is prone to collect internal condensation, appropriate conduit traps, drains and seals must be employed to prevent condensation from collecting inside the PAX1 enclosure.

3. Installation *continued*

Wiring

The PAX1 can be controlled with three different control interfaces (Analogue, Pulse & Modbus). The wiring diagrams, Figures 3-11, below show the connections required to operate the unit based on the control type as well as connections to other features such as position feedback and alarm switches.

The terminal blocks can accommodate wire size up to 1.5 mm (14 ga.). Due to safety requirements, wire entering TB2 and TB3 terminal blocks (alarm relays) require ferrules (supplied) to provide proper insulation for high voltage AC connections. The AC powered PAX units also require crimp ferrules for wires entering the terminal block at connections 11 & 12.

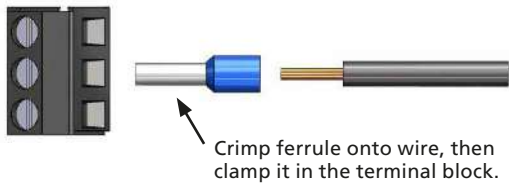

Figure 1

Grounding

An internal ground lug is provided. Use the ring terminal provided to make an internal ground connection to the unit using 14 to 18 ga. wire.

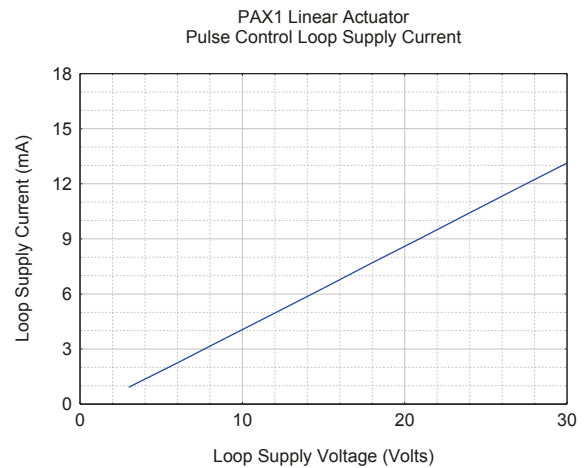
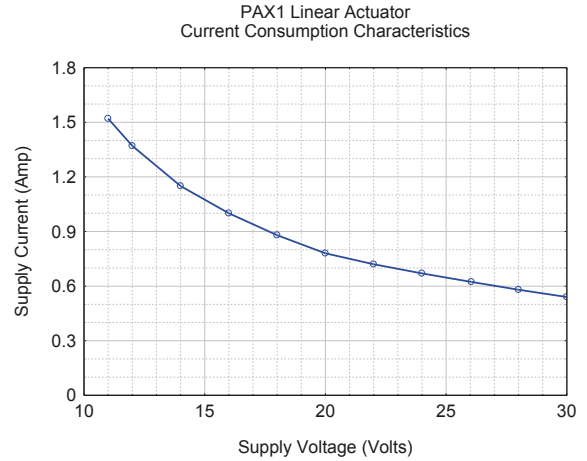

Figure 2

Power Supply Sizing

For 12 VDC operation, the recommended power supply should have 2 amp capacity minimum.

For 24 VDC operation, the recommended power supply should have 1 amp capacity minimum.



4. Electrical Connections, DC Power

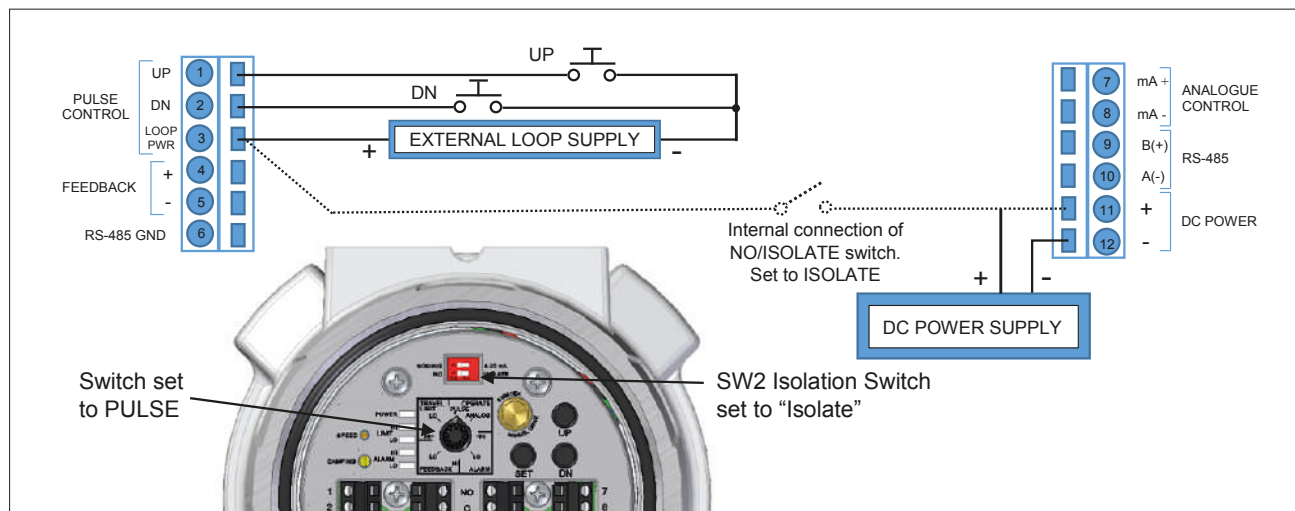

Figure 3 Electrically isolated pulse input control using an external loop supply

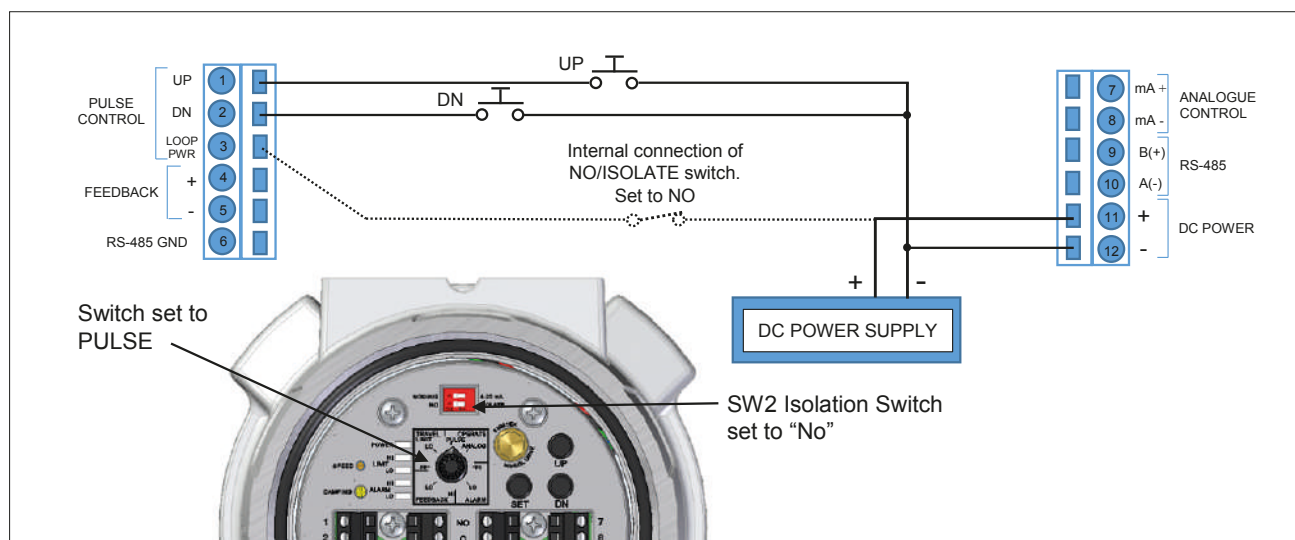

Figure 4 Non isolated pulse input control using common power supply for pulse control loop power

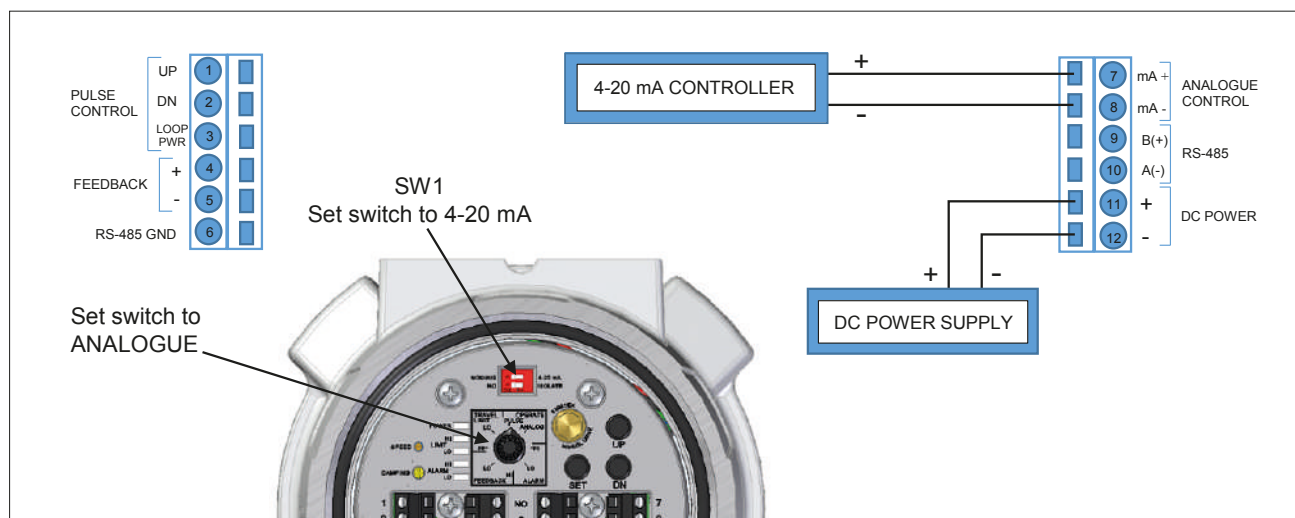

Figure 5 4-20 mA analogue control

4. Electrical Connections, DC Power *continued*

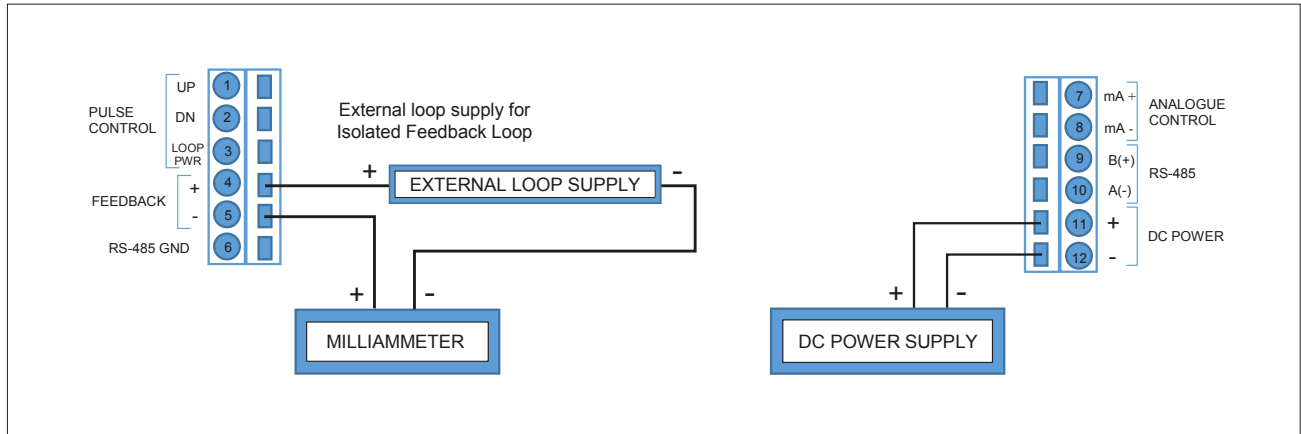

Figure 6 Power and Feedback Connections

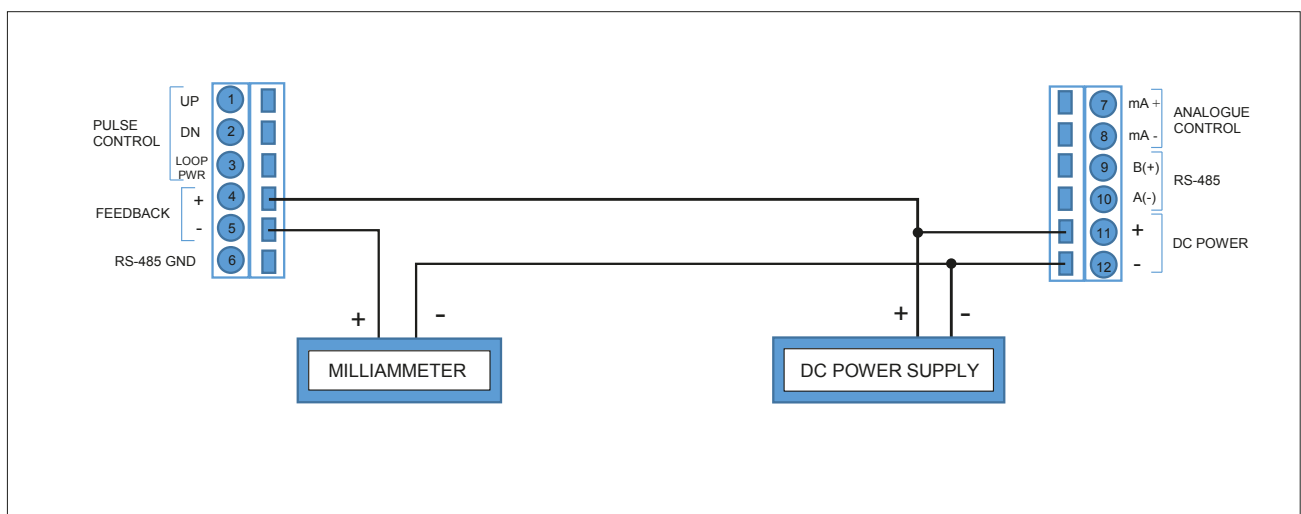

Figure 7 Non Isolated Feedback using Power Supply for feedback loop power

5. Electrical Connections, AC Power

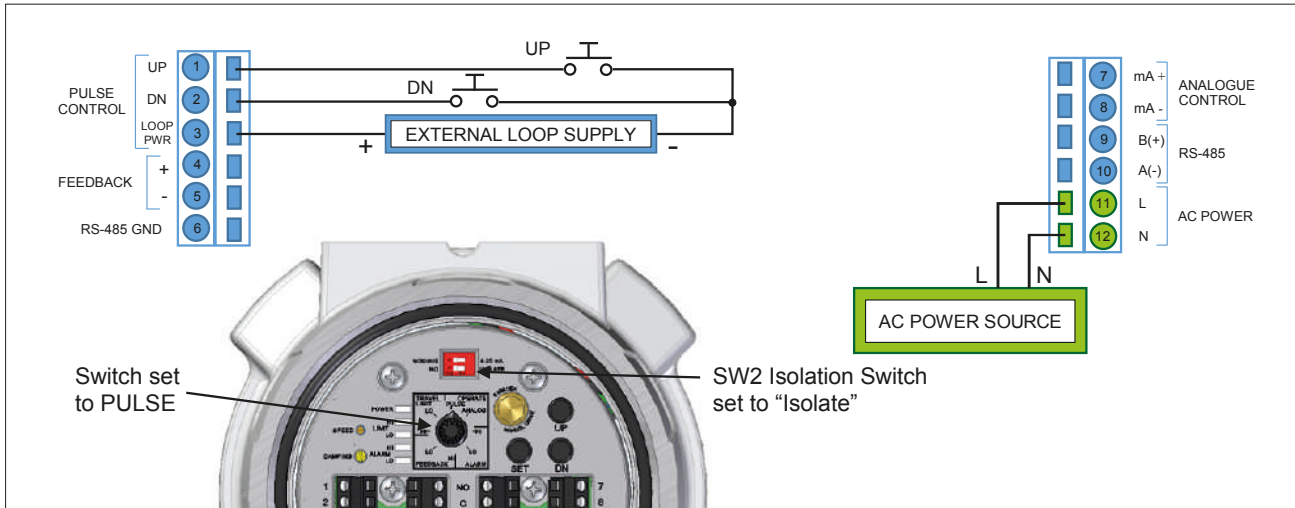

Figure 8 Electrically isolated pulse input control using an external loop supply

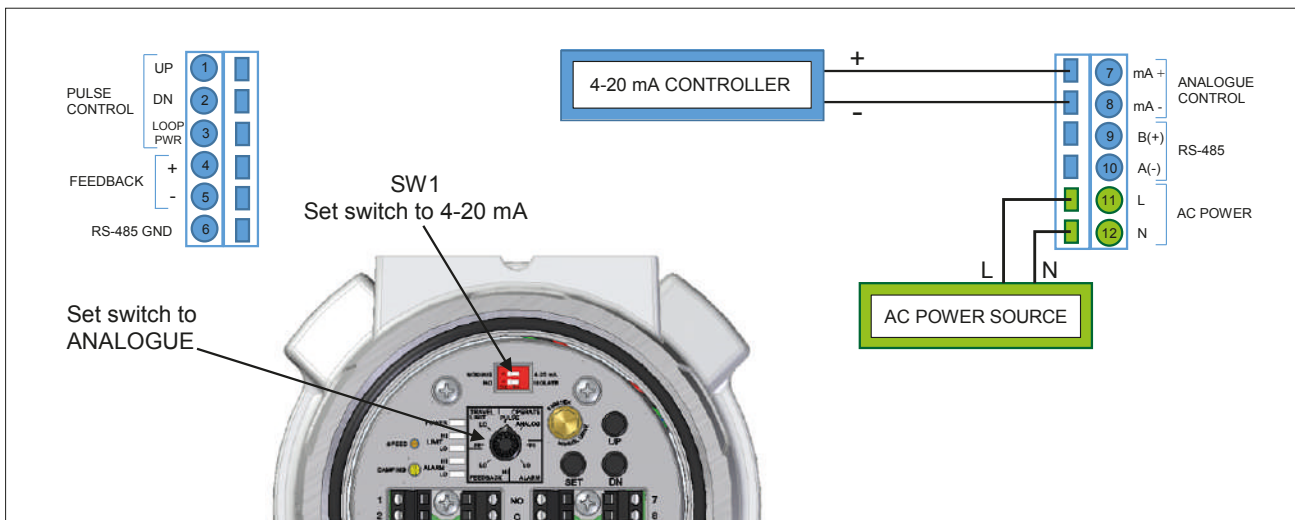

Figure 9 4-20 mA analogue control

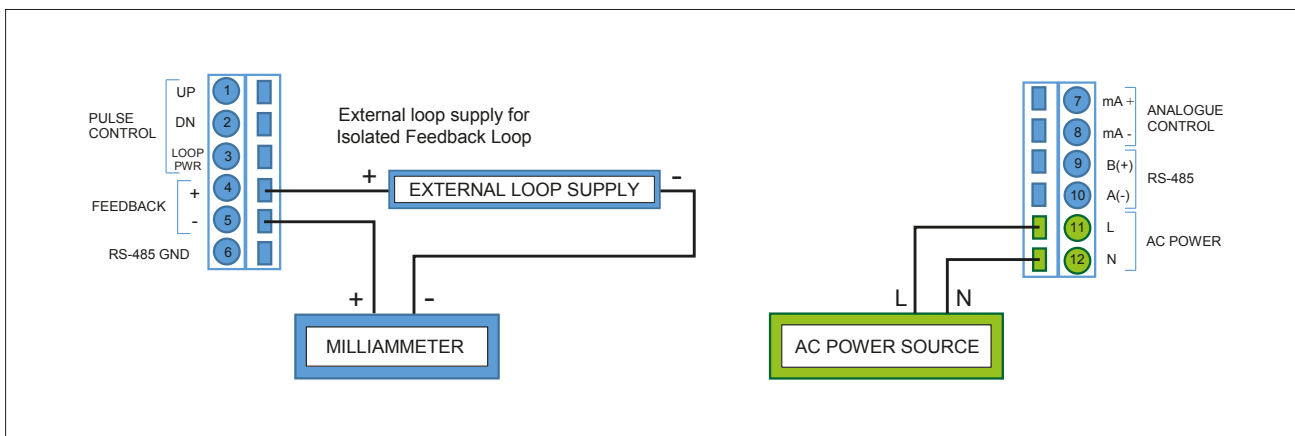

Figure 10 Power and Feedback Connections

5. Electrical Connections, AC Power *continued*

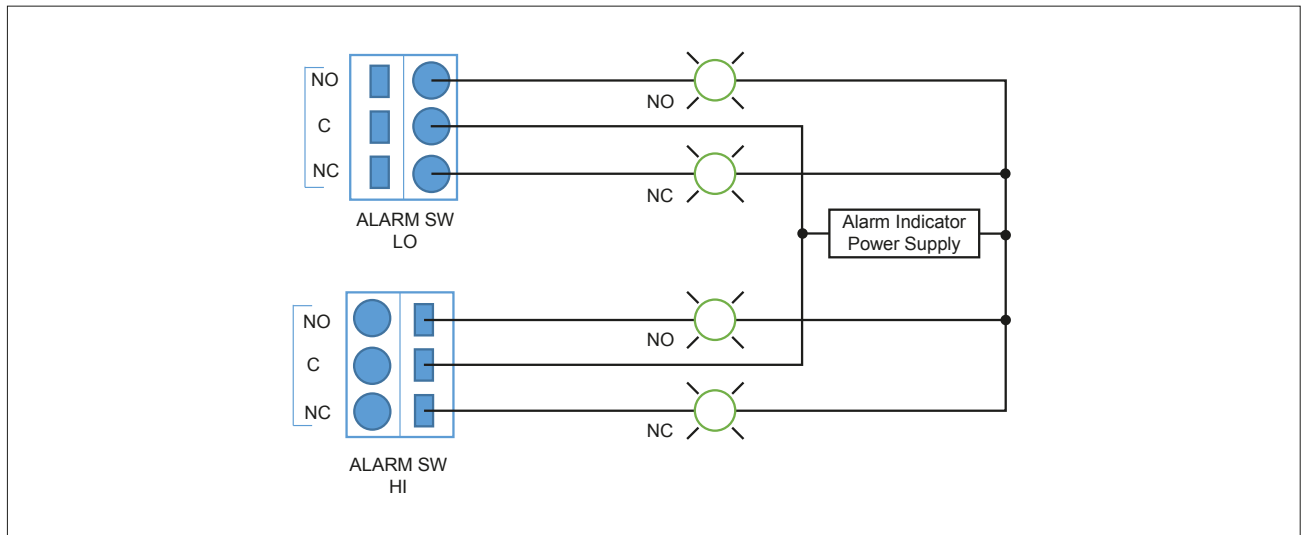

Figure 11 Alarm Switch Connections

6. User Interface

Setup switch

Eight position rotary SETUP switch, for setting control type and configuring travel limits, Alarm points and Feedback calibration.

Configuration DIP switches

SW1 selects 4-20 mA for analogue control input or Modbus communication control.

SW2, Isolate: The Pulse control inputs are isolated from the DC power supply providing power to the unit and must be powered from a separate external power source. (See *Figure 3*). This is useful for long runs of the control lines to eliminate ground loops with local power supply and control equipment.

SW2, NO: The Pulse control input circuit is connected to the DC power supply providing power to the unit. No external control loop supply required. One side of the control switches must be connected to the – (neg) power supply connection. (See *Figure 4*).

Note: SW2 is nonfunctional for AC powered units. The Pulse control input for the AC powered actuator is configurable for isolated control only. There is no internal connection to the power supply for the AC powered units so the actuator must be wired as an isolated input unit regardless of the position of switch SW2.

Push button switches

UP: Moves the pressure regulator setpoint to a higher pressure.

DN: Moves the pressure regulator setpoint to a lower pressure.

SET: Used in conjunction with the rotary SETUP switch to set the pressure limits, alarm points, and analogue feedback calibration.

LED indicators

PWR: Green, Supply voltage is between 11 and 30 VDC. Red, Voltage is less than 11 VDC or greater than 30 VDC.

LIMIT HI: Green, Hi limit not reached, thrust rod will move in both directions. Red, Hi Limit reached, thrust rod will move DOWN (RETRACT) only.

LIMIT LO: Green, Lo limit not reached, thrust rod will move in both directions. Red, Lo Limit reached, thrust rod will move UP (EXTEND) only.

ALARM HI: Green, Hi Alarm not reached, Hi Alarm relay not energized. Red, Hi Alarm reached, Hi Alarm relay is energized. NO contact is closed.

ALARM LO: Green, Lo Alarm not reached, Lo Alarm relay not energized. Red, Lo Alarm reached, Lo Alarm relay is energized. NO contact is closed.

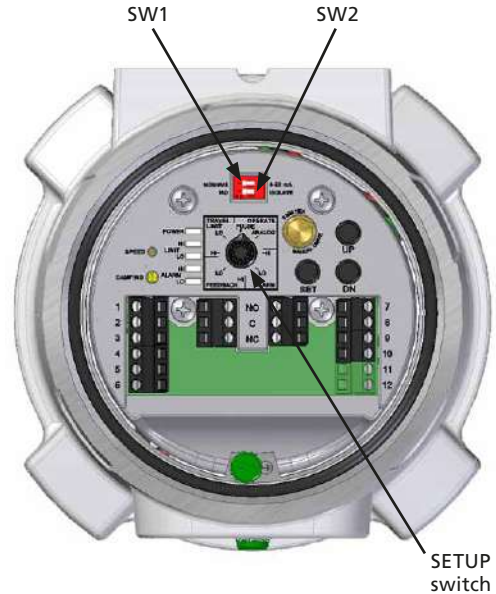

Figure 12

Speed potentiometer

20 turn potentiometer. Adjusts actuator speed from 1.2 mm/min to 60 mm/min.

In order to get the utmost performance from the PAX1, the motor speed range can be adjusted beyond its stall speed. The actual maximum attainable operating speed will depend on the supply voltage, and the maximum required thrust. The maximum required thrust will depend on the pressure regulator model and its pressure range.

If the motor stalls before the maximum pressure range can be attained, reduce the motor speed.

Damping potentiometer

1 turn potentiometer. Adjusts start ramp speed rate. Use this control to prevent hunting of the output about the setpoint.

Manual control

The actuator can be manually operated by manually turning the motor through an 8 mm ($5/16$ ") female hex socket located through the hole in the top PCA cover near the SET button. Turning the motor clockwise extends the thrust rod, counter clockwise retracts the thrust rod. Take care not to drive the actuator into its mechanical stops and over torque the gearbox as damage to the gearbox may result.

7. Commissioning

WARNING

NOTE: multiple power sources possible. Do not remove the cover in the field without first removing all power from the unit.

Commissioning must be done in a safe area before installing in a hazardous area.

Obtain special work permit before removing the cover and making powered adjustments in the field.

1. Setting end travel limits

This procedure adjusts the end travel limits without changing the signal current associated with the 0% & 100% positions.

- 1.1 Disconnect the analogue input from the 4-20 mA input terminals.
- 1.2 Turn on power to the unit.
- 1.3 Position the SETUP SWITCH to the TRAVEL LIMIT LO setting.
- 1.4 Using the UP (EXTEND) and DN (RETRACT) buttons under the cover, adjust the pressure regulator to its lowest desired output pressure.
- 1.5 Press the SET button and wait for the Limit Lo LED to turn from Green to Red and back to Green to set the low pressure limit.
- 1.6 Position the SETUP SWITCH to the TRAVEL LIMIT HI setting.
- 1.7 Using the UP (EXTEND) and DN (RETRACT) buttons under the cover, adjust the pressure regulator to its highest desired output pressure.
- 1.8 Press the SET button and wait for the Limit Hi LED to turn from Green to Red and back to Green to set the high pressure limit.
- 1.9 Position the SETUP switch to the OPERATE/PULSE or OPERATE/ANALOGUE to operate the actuator normally.
- 1.10 When in the OPERATE/PULSE mode, the actuator will respond to external pulse control inputs and will stop when the pressure regulator reaches either pressure limit. The LIMIT LO and LIMIT HI LEDs will change from Green to Red when the limit is reached. The internal UP (EXTEND) and DN (RETRACT) push buttons will respond likewise.
- 1.11 When in the TRAVEL LIMIT/LO or HI, mode, the external pulse control inputs are disabled. The internal UP (EXTEND) and DN (RETRACT) push buttons will be active and will ignore the previous pressure limits so that new limits may be set beyond the previously set limits. The LIMIT LO and LIMIT HI LEDs will continue to operate from the previously set limits until new limits are set.

2. Setting Analogue Control Current

This procedure adjusts both the end travel limits and the signal current associated with the 0% & 100% positions.

- 2.1 Connect a 4-20 mA signal source to the 4-20 mA input terminals.
- 2.2 Turn on power to the unit.
- 2.3 Set SW1 to 4-20 mA.
- 2.4 Position the SETUP SWITCH to the TRAVEL LIMIT LO setting.
- 2.5 Using the UP (EXTEND) and DN (RETRACT) buttons under the cover, adjust the output pressure to the lowest desired pressure.
- 2.6 Apply the desired control current to the Analogue Control input terminals for this pressure setting.
- 2.7 Press the SET button and wait for the Limit Lo LED to turn from Green to Red and back to Green to set the low travel limit and corresponding control current.
- 2.8 Move the SETUP SWITCH to the TRAVEL LIMIT HI setting.
- 2.9 Using the UP (EXTEND) and DN (RETRACT) buttons under the cover, adjust the output pressure to the highest desired pressure.
- 2.10 Apply the desired control current to the Analogue Control input terminals for this pressure setting.
- 2.11 Press the SET button and wait for the Limit Hi LED to turn from Green to Red and back to Green to set the high travel limit and corresponding control current.
 - 2.11.1 Note: for **Reverse Acting Mode**, Input the High current signal at the most retracted position and press the SET button. Input the low current signal at the most extended position and press the SET button.
- 2.12 Position the SETUP switch to the OPERATE/ANALOGUE to operate the actuator from the Analogue Control input terminals.
- 2.13 ERROR SIGNALS – If both the Hi Limit and Lo Limit LED's blink red, then an error has occurred in setting the Analogue Control signal. The most common error is setting the Lo and Hi Limit and forgetting to change the control current. In this case, the Lo Limit and Hi Limit are set with the same current. This error signal also occurs if the difference in control current between the Lo Limit and Hi Limit is less than 4 mA. Correcting either the Lo Limit or Hi Limit setting or both will resolve the problem.

7. Commissioning *continued*

3. Setting Alarm Switches

- 3.1 Position the SETUP SWITCH to the ALARM SWITCH LO setting.
- 3.2 Using the UP (EXTEND) and DN (RETRACT) buttons, adjust the pressure regulator to its LO ALARM pressure.
- 3.3 Press the SET button and wait for the ALARM LO LED to turn from Green to Red and back to Green to set the ALARM SWITCH LO pressure setting.
- 3.4 Turn the SETUP SWITCH to the ALARM SWITCH HI setting.
- 3.5 Using the UP (EXTEND) and DN (RETRACT) buttons, adjust the pressure regulator to its HI ALARM pressure.
- 3.6 Press the SET button and wait for the ALARM HI LED to turn from Green to Red and back to Green to set ALARM SWITCH HI pressure setting.
- 3.7 Position the SETUP SWITCH to the OPERATE PULSE or ANALOGUE mode for normal operation.

4. Setting Feedback Output

- 4.1 Position the SETUP SWITCH to the OPERATE PULSE mode.
- 4.2 Using the internal DN (RETRACT) push button, adjust the actuator to its desired retracted limit position.
- 4.3 Move the SETUP SWITCH to the FEEDBACK LO setting.
- 4.4 Using the UP (EXTEND) and DN (RETRACT) button, and monitoring the Analogue Feedback current on the milliammeter, adjust the output current to the desired value for this position.
- 4.5 Press the SET button and wait for the LIMIT LO & ALARM LO LED to simultaneously turn from Green to Red and back to Green to set the FEEDBACK LO output current.
- 4.6 Position the SETUP SWITCH to the OPERATE PULSE mode.
- 4.7 Using the internal UP (EXTEND) push button, adjust the actuator to its desired extended limit position.
- 4.8 Move the SETUP SWITCH to the FEEDBACK HI setting.
- 4.9 Using the UP (EXTEND) and DN (RETRACT) button, and monitoring the Analogue Feedback current on the milliammeter, adjust the output current to the desired value for this position.

- 4.10 Press the SET button and wait for the LIMIT HI & ALARM HI LED to simultaneously turn from Green to Red and back to Green to set the FEEDBACK HI output current.
- 4.11 Position the SETUP SWITCH to the OPERATE PULSE or ANALOGUE mode for normal operation.
- 4.12 **Reverse Acting Mode for Feedback**
- 4.13 Position the SETUP SWITCH to the OPERATE PULSE mode.
- 4.14 Using the internal DN push button, adjust the pressure regulator to its low pressure limit position.
- 4.15 Position the SETUP SWITCH to the FEEDBACK LO setting.
- 4.16 Using the UP and DN button, and monitoring the Analogue Feedback current on the milliammeter, adjust the feedback output current to the desired value (i.e. 20 mA) for this position.
- 4.17 Press the SET button and wait for the LIMIT LO & ALARM LO LED to simultaneously turn from Green to Red and back to Green to set the FEEDBACK LO output current.
- 4.18 Position the SETUP SWITCH to the OPERATE PULSE mode.
- 4.19 Using the internal UP push button, adjust the pressure regulator to its high pressure limit position.
- 4.20 Move the SETUP SWITCH to the FEEDBACK HI setting.
- 4.21 Using the UP and DN button, and monitoring the Analogue Feedback current on the milliammeter, adjust the feedback output current to the desired value (i.e. 4 mA) for this position.
- 4.22 Press the SET button and wait for the LIMIT HI & ALARM HI LED to simultaneously turn from Green to Red and back to Green to set the FEEDBACK HI output current.
- 4.23 Position the SETUP SWITCH to the OPERATE PULSE or OPERATE ANALOGUE mode for normal operation.
- 4.24 Note: The feedback will output the current of the setting of FEEDBACK LO and FEEDBACK HI when the rotary switch is moved to these positions regardless of the position of the actuator.

7. Commissioning *continued*

5. Manual adjustment of Pressure Regulator

WARNING

Manual adjustment must only be done when power is removed from the unit.

NOTE: Multiple power sources possible. Do not remove cover in the field without first removing all power from the unit.

- 5.1 The Pressure Regulator output may be manually adjusted via an 8 mm ($\frac{5}{16}$ ") female hex interface located through the top of the unit with the cover removed.
- 5.2 Turn the adjustment clockwise to increase the output pressure and counter clockwise to decrease the output pressure.
- 5.3 Take care when manually adjusting the actuator as you can damage the unit if you force the actuator into its mechanical stops.

6. Restore Factory Defaults

The PAX1/PAXL actuator can be restored to its original factory settings using the following procedure.

- 6.1 Position the setup Switch to OPERATE/ANALOGUE.
- 6.2 Simultaneously press and hold the UP (EXTEND), DN (RETRACT), and SET buttons. For approximately 5 seconds, all of the LEDs will flash red on and off, and then they will stop flashing.
- 6.3 Release the buttons and the LEDs will begin flashing again to indicate "Restore Factory Defaults" mode is activated.
- 6.4 Press the SET button to restore the PAX1/PAXL to factory default settings. The LEDs will then return to their normal state.
- 6.5 The "Restore Factory Defaults" routine will cancel if (a) the UP (EXTEND) or DN (RETRACT) buttons are pressed or (b) the SET button is not pressed within 20 seconds.

8. Installation Dimensions

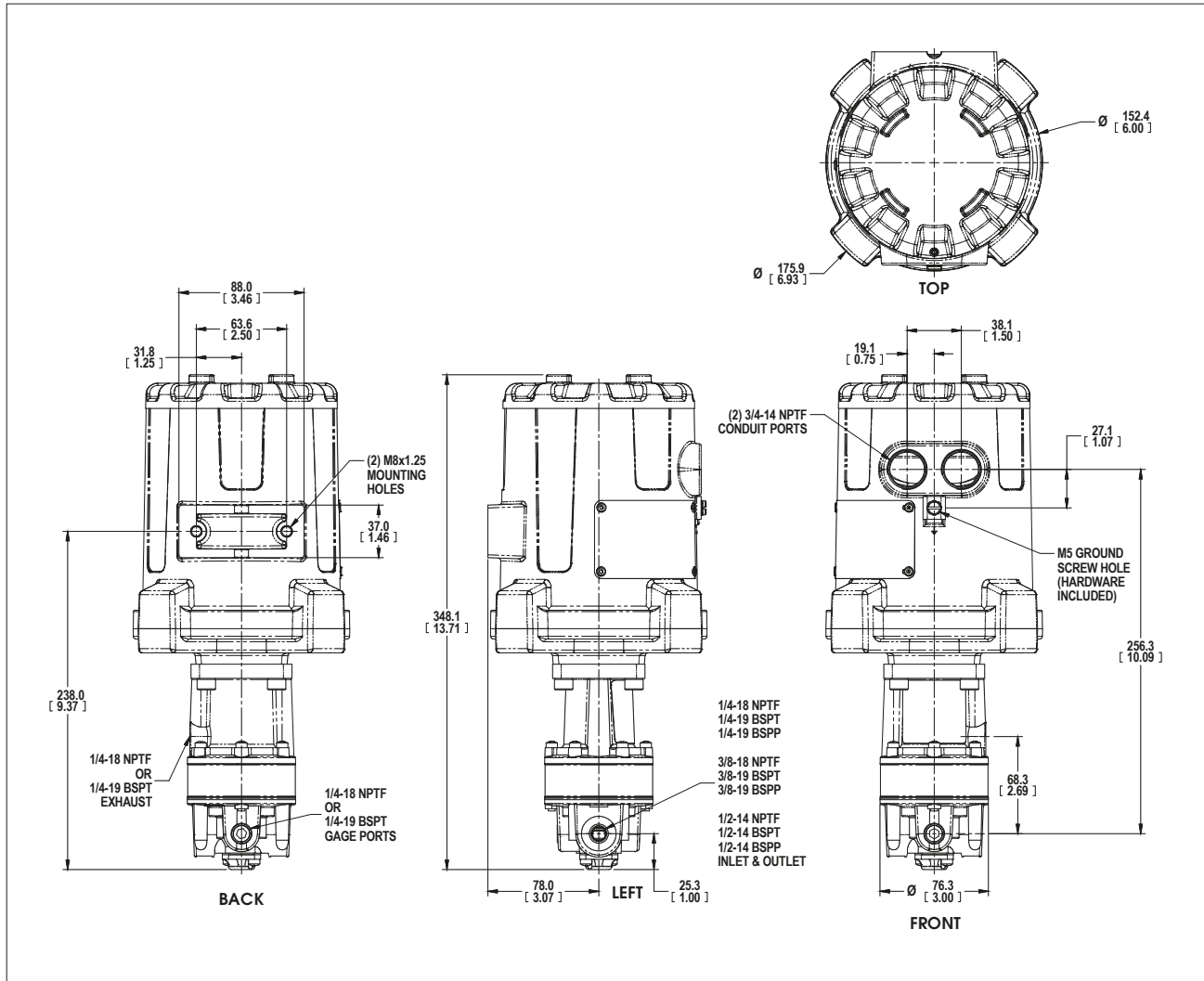

Figure 13 PAX1 & Model 10 Pressure Regulator

8. Installation Dimensions *continued*

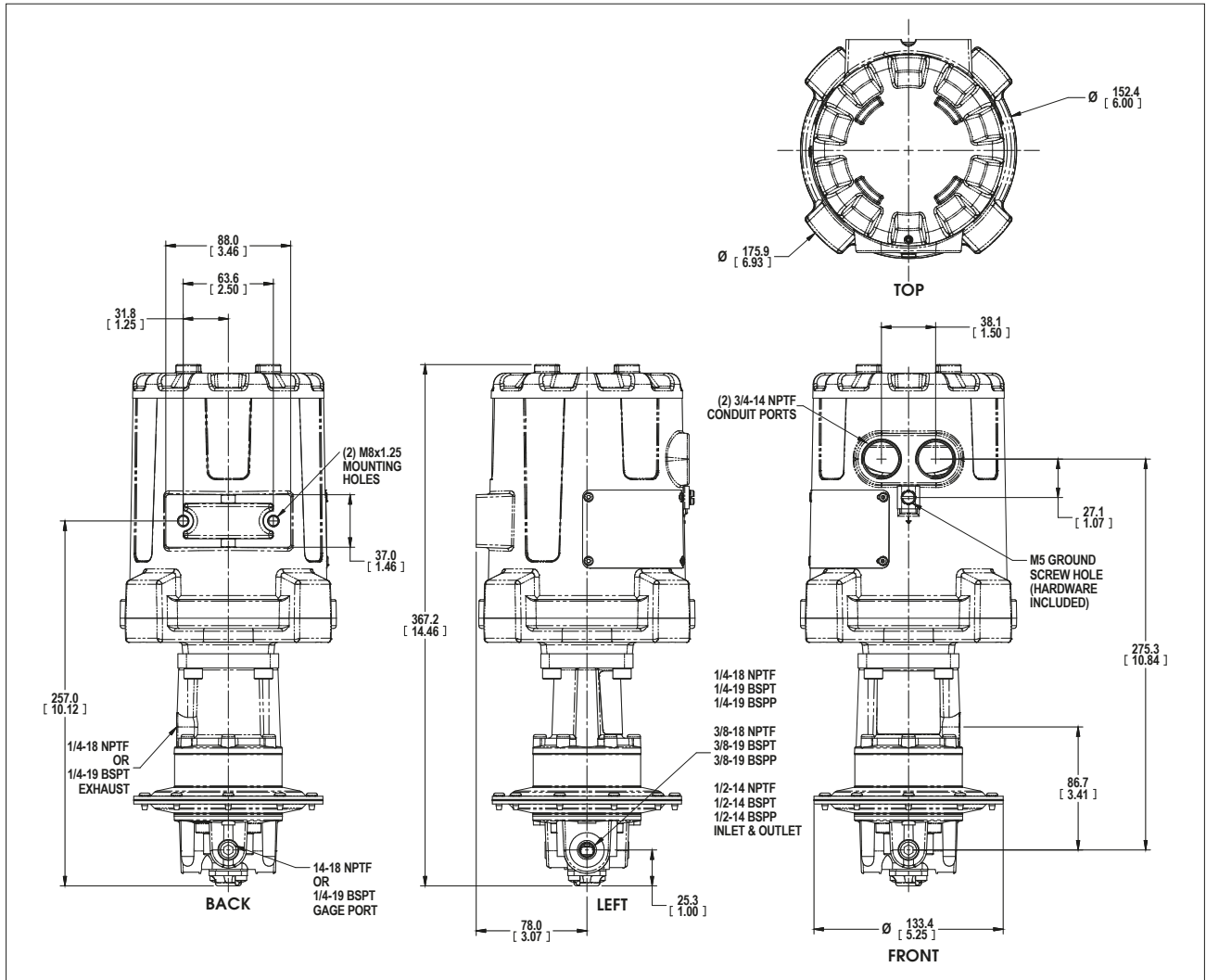

Figure 14 PAX1 & Model 11 Pressure Regulator

8. Installation Dimensions *continued*

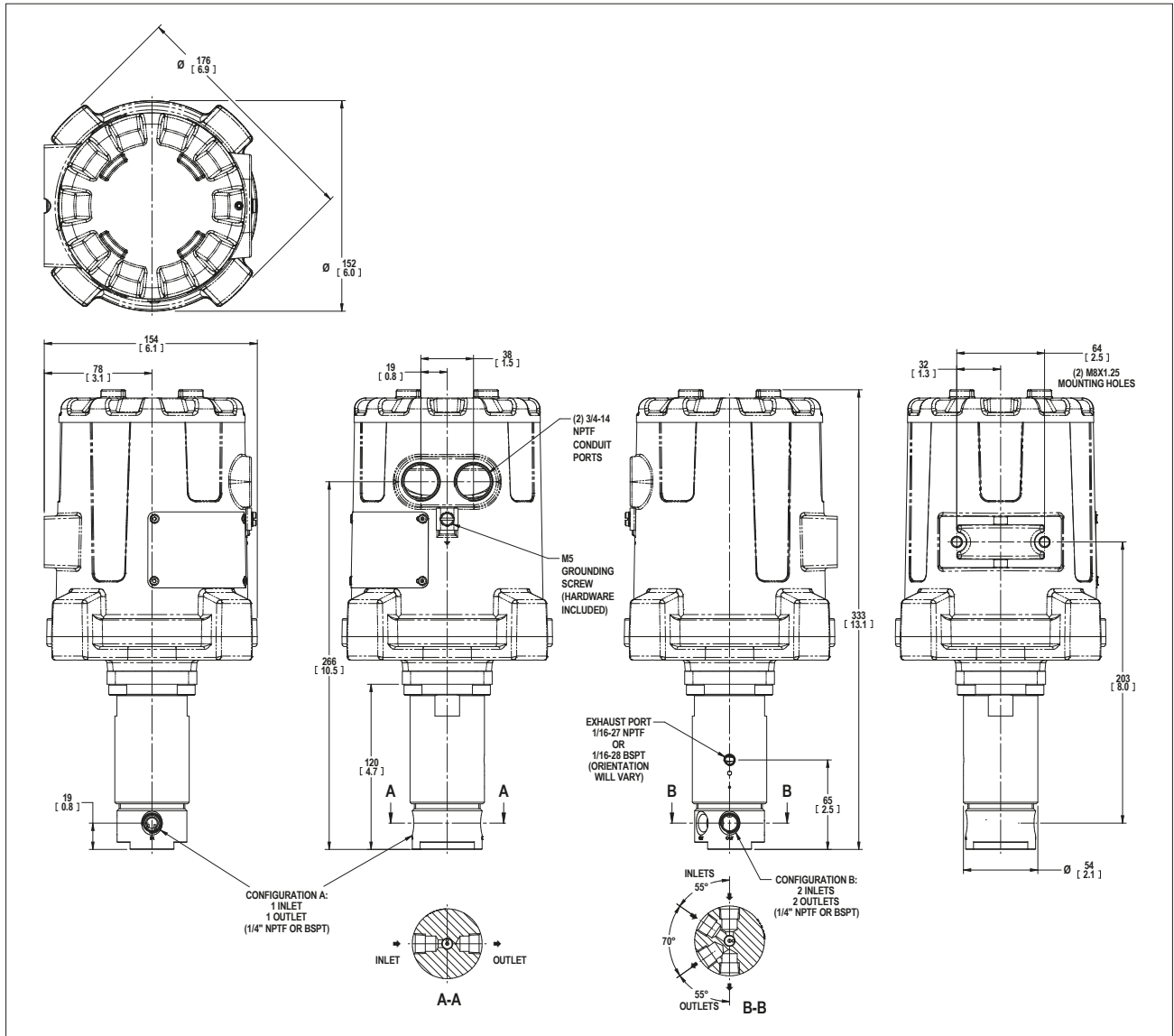

Figure 16 PAX1 & Model HPD or HPP Pressure Regulator

8. Installation Dimensions *continued*

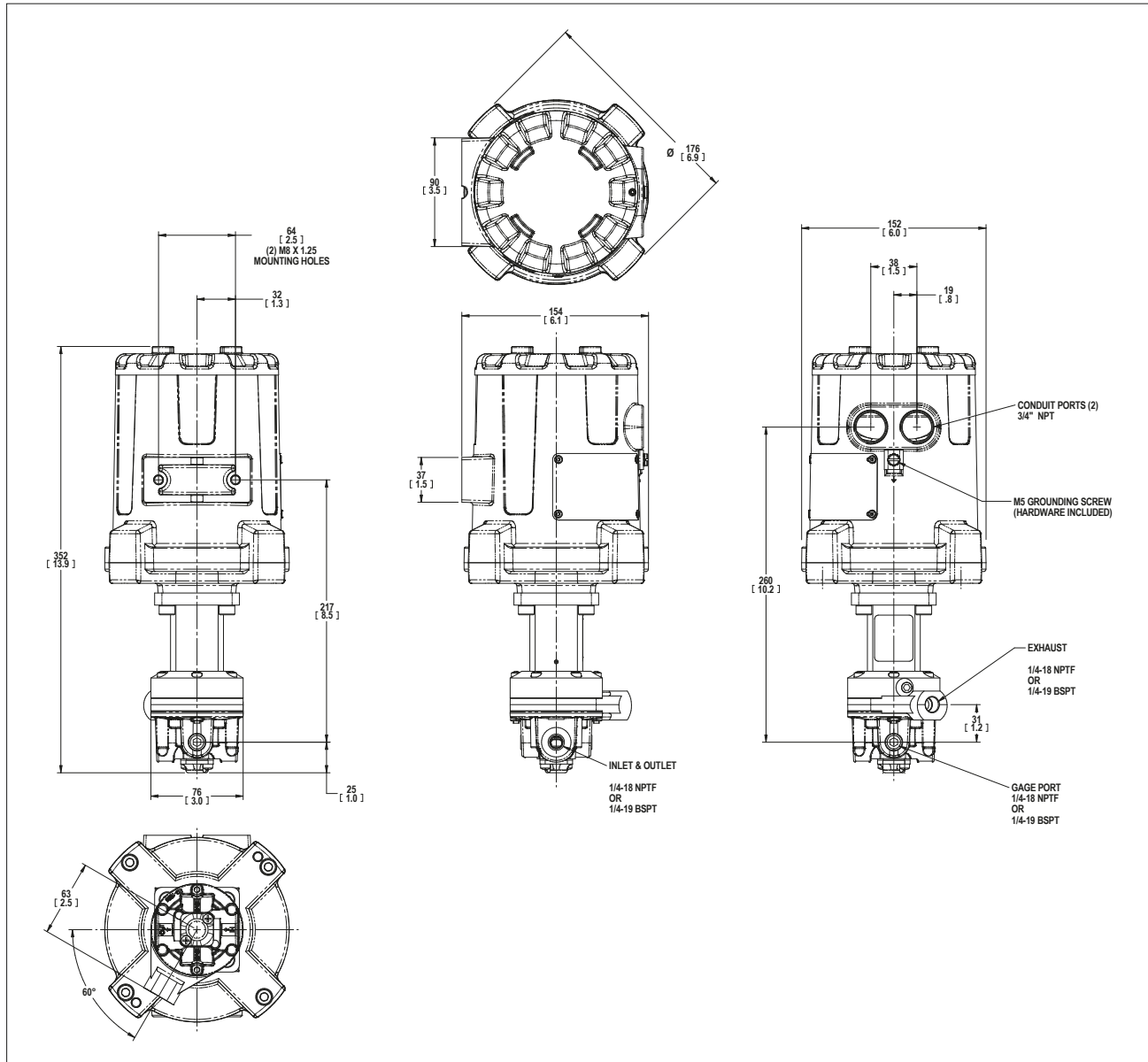

Figure 17 PAX1 & Model 81

8. Installation Dimensions *continued*

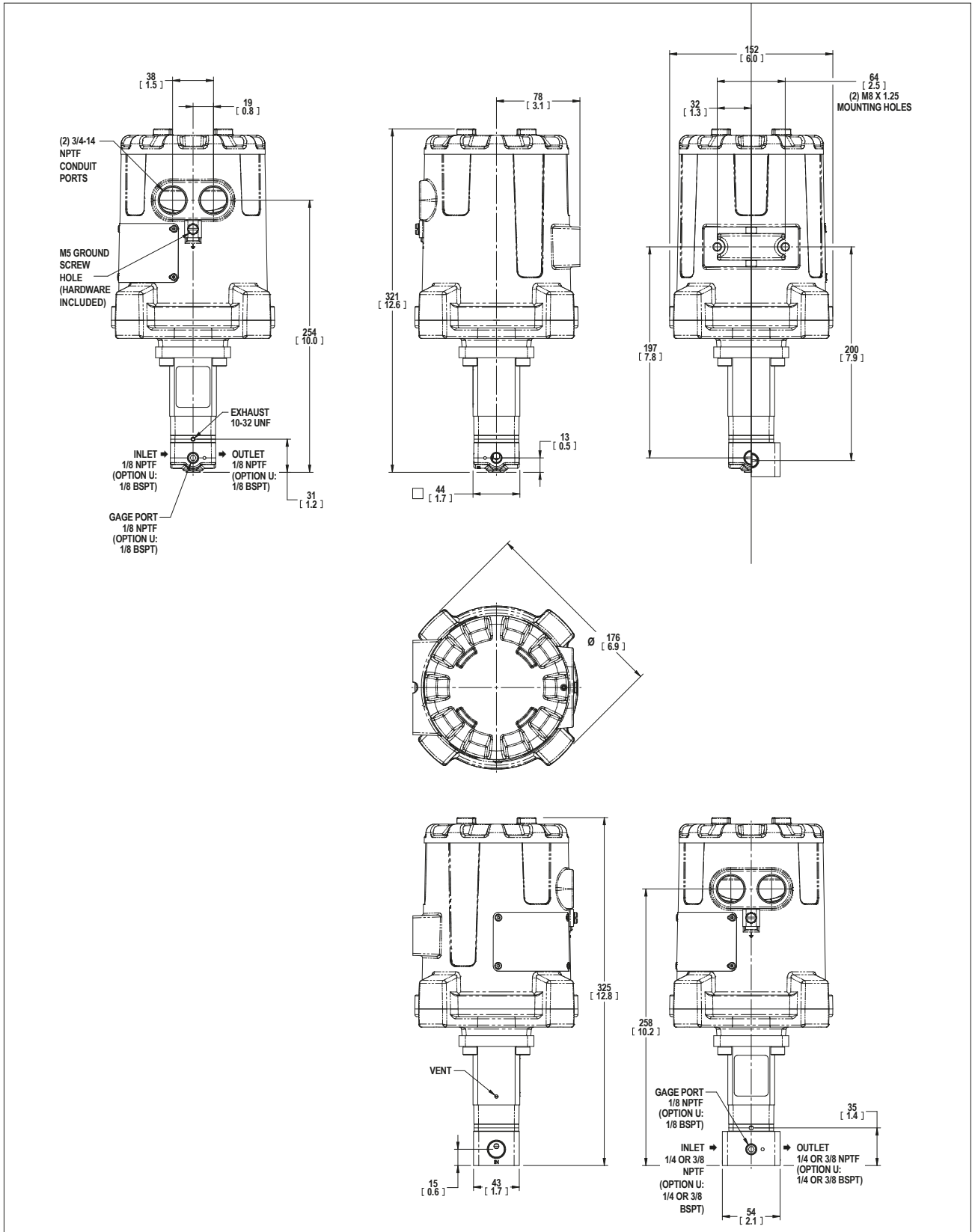

Figure 18 PAX1 & Model 80

8. Installation Dimensions *continued*

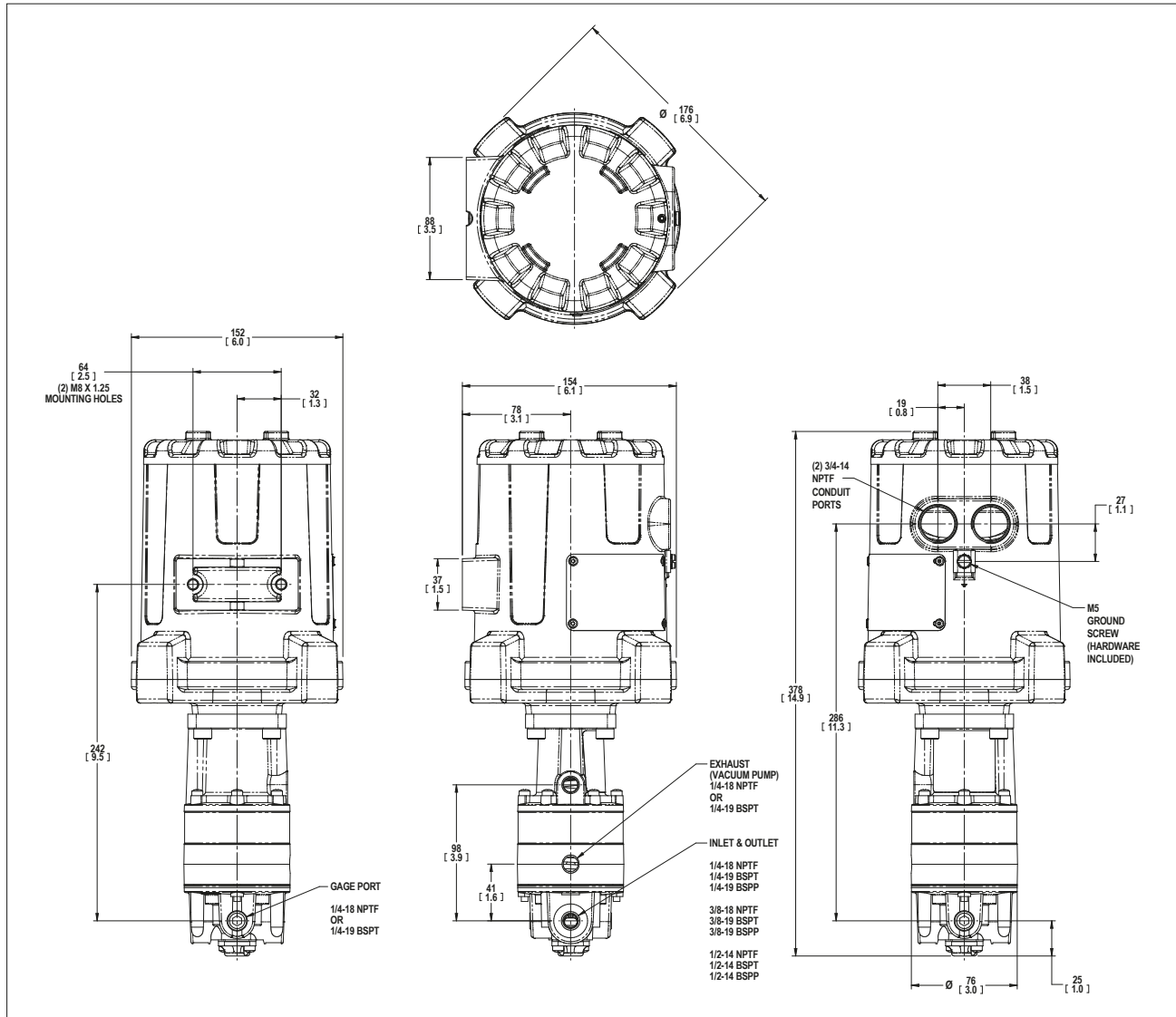

Figure 19 PAX1 & Model 16

9. Specifications

Electrical Supply (DC)

Power Supply Voltage	11-30 VDC
Power Consumption	22 W max, <1.5 W standby

Electrical Supply (AC)

Power Supply Voltage	95-250 VAC, 47-63 Hz
Power Consumption	30 W max

Actuation Electrical, Analogue

Actuation Control	4-20 mA, 1500 V optically isolated from power supply, Switch for common power supply
Actuation Supply	11-30 VDC (Loop Supply)
Min Current Span	4 mA; the difference in the control current setting between the Lo Limit, and Hi Limit

Actuation Electrical, Pulse

Actuation Control	Switch Closure Sinking, (1) increase, (1) decrease
Actuation Current	10 mA sink, optically isolated 1500 V, Switch for common power supply
Actuation Supply	4 VDC minimum, 30 VDC maximum

Monitor

Alarm Switches	Customer use, (2) SPDT each switch, 1 A 250 VAC, (Mag latching relay)
Position Feedback	Optional, Isolated 4-20 mA, 11-30 VDC loop supply

Electrical Design Limits

Supply Voltage Limits (DC)	11 VDC min, 30 VDC max
Supply Voltage Limits (AC)	95 VAC min, 250 VAC max, 47-63 Hz
Analogue input Limits	3.5 mA min, 21 mA max, 100 mA w/o damage
Analogue Output Limits	3.5 mA min, 21 mA max
External loop supply limits	4 VDC min, 30 VDC max
Alarm Switches	1 A 250 VAC SPDT

Customer interface

Electrical Connections	Screw terminal block under cover, 14-30 AWG
Actuator speed	Multi-turn pot, 1.2 – 60 mm/min*
Limit adjustments	Push button switch to accept current thrust rod position for (2) End of Travel limit, & (2) Alarm Switch, and Analogue Feedback Calibration
Setup Switch	8 position rotary switch.
Damping	Single-turn pot, 8:1 turn down
Isolation Switch	Pulse Control Loop – Isolated/ common to power supply

Actuator Performance

Maximum Stroke	25 mm
Maximum Force	2000 N (450 lbf) Continuous Duty 2890 N (650 lbf) for Low Duty Cycle Applications
Max Linear Speed	60 mm/min
Actuator shaft	M10 x 2 mm trapezoidal screw thd.
Power Up Initialization Time	Analogue Control: 2.1 sec. Pulse Control: 0.9 sec. Feedback output: 0.9 sec.

EMC Ratings

FCC 47 CFR Part 15, Subpart B:2020
IC ICES-003:2016 Ed.6
CISPR 11:2009 Ed.5
IEC 61326-1:2012/07/10 Ed.2, Immunity - Equipment intended to be used in an industrial environment. Emissions per Section 7.2.

Environmental Ratings

Oper. Temp. Range	-40 to +80 °C, <50% Duty Cycle, <10 min cycle period (Motor Actuated) -40 to +70°C, Continuous Duty (Motor Actuated)
Ingress Protection	IP66/68 See agency specific approvals on p.2
NEMA	Type 4X/6P See agency specific approvals on p.2

*Actuation speed may need to be limited to achieve rated thrust at lower supply voltages.

10. Maintenance

⚠ CAUTION

Shutting off Motor Set Pressure Regulator and disconnecting associated equipment can cause dangerous system conditions to exist. Ensure the System is properly prepared for maintenance to be performed on the unit before taking it out of service.

Periodic lubrication of Thrust Rod

After 20,000 operating cycles, re-lubricate the actuator thrust rod.

Make sure it is safe to depressurize the system. Move the setup knob to the Operate Pulse mode and pressing the Jog DN button, retract the thrust rod to its most retracted position (Zero output pressure from the pressure regulator). To expose the thrust rod remove the four bolts that attach the pressure regulator to the actuator housing. Remove the pressure regulator and Thrust Rod Cap exposing the Thrust Rod. With the setup knob to the Operate Pulse mode and pressing the Jog UP button, extend the thrust rod to its most extended position. Apply Dow Corning G-4700 lubricant to the exposed thrust rod thread. Using the Jog DN button, retract the thrust rod to its most retracted position. Re-install the thrust rod cap and pressure regulator.

11. PAX1 Actuator & Pressure Regulator Assembly

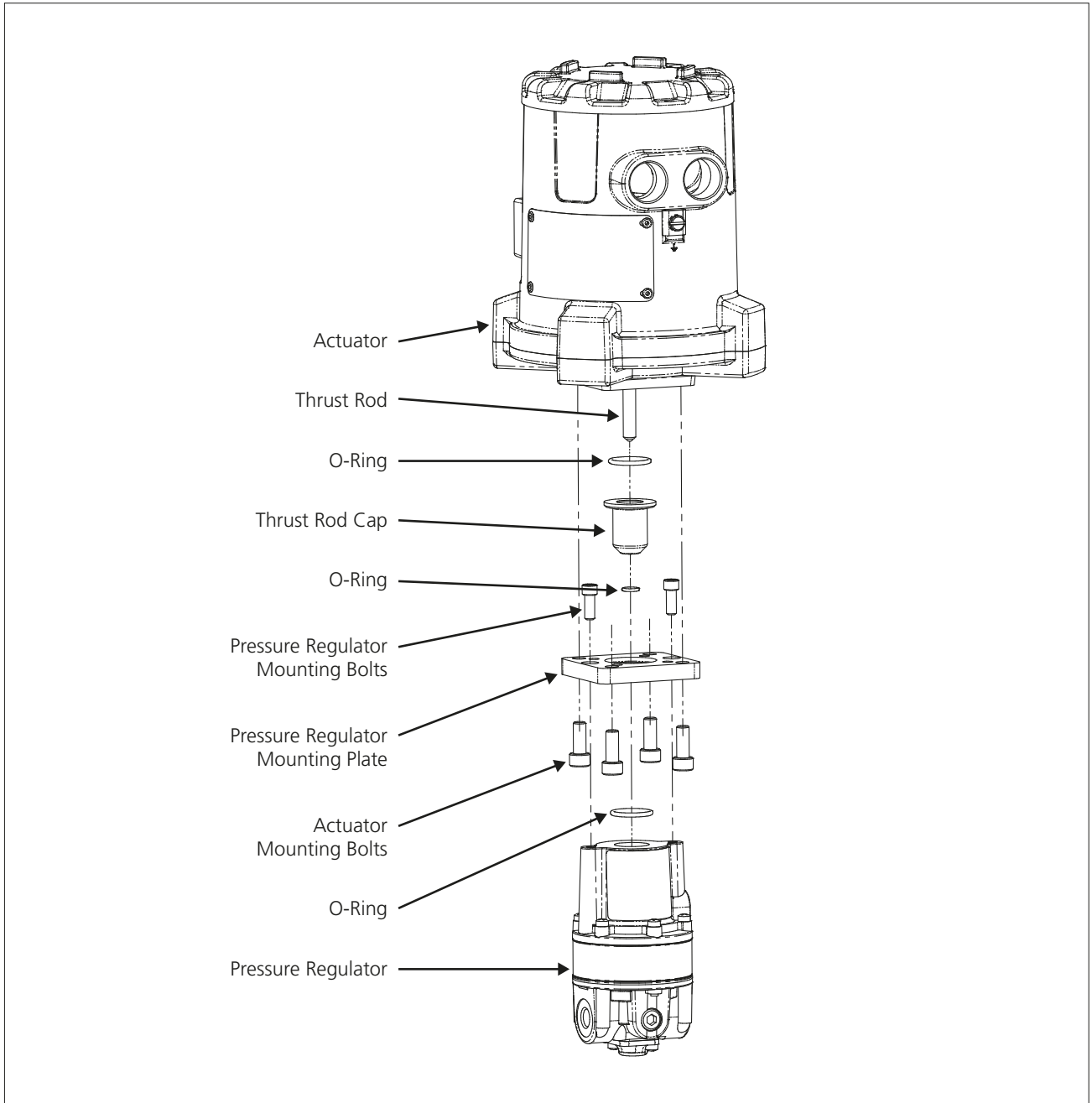

Figure 20 PAX1 Actuator & Pressure Regulator Assembly

Contact factory for service kits.

rotork®



www.rotork.com

A full listing of our worldwide sales and service network is available on our website.

Rotork plc
Brassmill Lane, Bath, UK
tel +44 (0)1225 733200
email mail@rotork.com

Rotork Instruments North America
3920 West Point Blvd, Winston-Salem, NC 27103, USA
tel +1 (336) 659-3400
email US-WS-CS@rotork.com

PUB136-003-00
Issue 03/23

As part of a process of on-going product development, Rotork reserves the right to amend and change specifications without prior notice. Published data may be subject to change. For the very latest version release, visit our website at www.rotork.com

The name Rotork is a registered trademark. Rotork recognises all registered trademarks. Published and produced in the UK by Rotork. POLJB0323