



## FUNCTIONAL SAFETY CERTIFICATE

This is to certify that the

***1500 & 1600 Series 3/2 Single Pilot Operated Valves***

Manufactured by

***Rotork Midland Ltd***

Patrick Gregory Rd,  
Wolverhampton,  
West Midlands,  
WV11 3DZ.

Has been assessed by Sira Certification Service with reference to the Hardware and Systematic Safety Integrity and found to meet the requirements of

**IEC 61508-2:2010  
Routes 1<sub>H</sub> & 1<sub>S</sub>  
Systematic Capability (SC3)**

As an element/subsystem suitable for use in safety related systems performing safety functions up to and including

**SIL 3 capable with HFT=0 (1oo1)\***

When used in accordance with the scope and conditions of this certificate.

\* This certificate does not waive the need for further functional safety verification to establish the achieved Safety Integrity Level (SIL) of the safety related system

Certification Manager:

  
Mr. W Thomas

Initial Certification: 06/01/2012  
This certificate issued: 16/02/2017  
Renewal date: 15/02/2022

This certificate may only be reproduced in its entirety, without any change.



Certificate No.: SIRA FSP 11015/04  
Form 7016 issue 3  
Page 1 of 8



**Sira Certification Service  
Part of CSA Group UK**  
Unit 6 Hawarden Industrial Park,  
Hawarden, CH5 3US, United Kingdom.  
Tel: +44 (0) 1244 670900  
Email: [ukinfo@csagroup.org](mailto:ukinfo@csagroup.org)  
Web: [www.csagroupuk.org](http://www.csagroupuk.org)

## Product description and scope of certification

The 1500 and 1600 series are a range of 3/2 single pilot servo operated spring return closed centre spool valves with port sizes of 1/4" (1500 series) and 1/2" (1600 series). All of the valves may be installed in the normally closed configuration, and may also be used normally open or as a diverter valve with the exception of SSV832B/2N-EP (low temperature 1500 series). All valves are suitable for use in offshore environments.

Both the solenoid and pilot operated variants of the valves have the same principle of operation. The inlet pressure supply is connected to port 1, the outlet (actuator) to port 2 and the exhaust to port 3. With no pressure signal applied to the pilot port the valve remains in the spring extended position with the inlet supply (port 1) blocked and the outlet (port 2) connected to the exhaust (port 3). When an appropriate pressure signal is applied to the pilot port the valve internals move to the spring compressed position; this connects the inlet (port 1) to the outlet (port 2) and blocks the exhaust (port 3). Upon removal of the pilot pressure signal the valve returns to the spring extended position as previously described. It should be noted that during the transition between these two states the valve is open centre (all ports connected).



Figure 1. Example pilot operated variant 3/2 single pilot operated valve

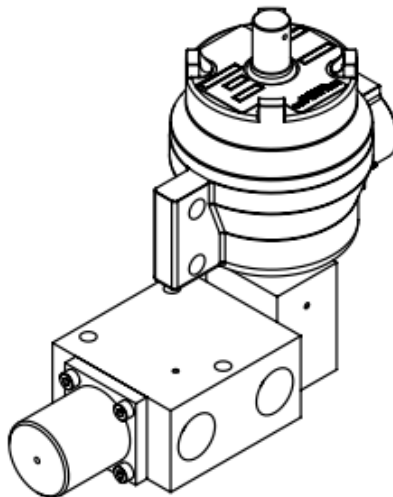

Figure 2. Example solenoid variant 3/2 single pilot operated valve



## Element Safety Function

The safety function of the certified equipment is:

*'To return the valve to a spring extended position when de-energised'*

## Certified Data in support of use in safety functions

The assessment has been carried out with reference to IEC61508:2010 for Hardware Safety Integrity using the Route 1<sub>H</sub> approach and the *Conformity Assessment of Safety-related Systems (CASS)* methodology for Systematic Safety Integrity using the Route 1<sub>s</sub> approach.

Based on the documents submitted by Rotork Midland Ltd, the Failure Mode and Effect analysis (FMEA) of the 1500 & 1600 Series 3/2 Single Pilot Operated Valves has verified the documents as evidence of conformity to IEC61508-2:2010 in respect of 'hardware safety integrity'. The components failure rates and modes have been sourced using RIAC automated data book and Item software reliability package. The tables 1 and 2 below summarise the FMEA assessments for both the pilot operated and solenoid operated variants of the 1500 & 1600 Series 3/2 Single Pilot Operated Valves.

**Table 1;** FMEA results of the pilot operated variants of the 1500 & 1600 Series 3/2 Single Pilot Operated Valves.

<b>Safety Function:</b> <i>'To return the valve to a spring extended position when de-energised'.</i>		
Summary of IEC 61508-2 Clauses 7.4.2 and 7.4.4	1500 & 1600 Series 3/2 single pilot Operated Valves – pilot operated	Verdict
Architectural constraints & Type of product A/B	HFT=0	Type A
Safe Failure Fraction (SFF)	91%	SIL 3
Random hardware failures: [h <sup>-1</sup> ]	$\lambda_{DD}$ 0.00E+00 $\lambda_{DU}$ 5.66E-08	
Random hardware failures: [h <sup>-1</sup> ]	$\lambda_{SD}$ 0.00E+00 $\lambda_{SU}$ 6.05E-07	
Diagnostic coverage (DC)	0.00%	
PFD @ PTI = 8760Hrs MTTR = 8 Hrs	2.48E-04	
Probability of Dangerous failure (High Demand - PFH) [h <sup>-1</sup> ]	5.66E-08	
Hardware safety integrity compliance	Route 1 <sub>H</sub>	
Systematic safety integrity compliance	Route 1 <sub>s</sub> See report R56A25037B	
Systematic Capability (SC1, SC2, SC3, SC4)	SC3, See report (R56A25037B)	
Hardware safety integrity achieved	SIL 3 achieved for low demand with HFT=0 (1oo1)	



**Table 2; FMEA results of the solenoid operated variants of the 1500 & 1600 Series 3/2 Single Pilot Operated Valves.**

<b>Safety Function:</b>			
<i>'To return the valve to a spring extended position when de-energized'.</i>			
Summary of IEC 61508-2 Clauses 7.4.2 and 7.4.4	1500 & 1600 Series 3/2 single pilot Operated Valves – Solenoid operated		Verdict
Architectural constraints & Type of product A/B	HFT=0		Type A
Safe Failure Fraction (SFF)	72%		SIL 2
Random hardware failures: [h <sup>-1</sup> ]	$\lambda_{DD}$ $\lambda_{DU}$	0.00E+00 5.83E-07	
Random hardware failures: [h <sup>-1</sup> ]	$\lambda_{SD}$ $\lambda_{SU}$	0.00E+00 01.47E-06	
Diagnostic coverage (DC)	0.00%		
PFD @ PTI = 8760Hrs MTTR = 8 Hrs	2.56E-03		
Probability of Dangerous failure (High Demand - PFH) [h <sup>-1</sup> ]	5.83E-07		
Hardware safety integrity compliance	Route 1 <sub>H</sub>		
Systematic safety integrity compliance	Route 1 <sub>S</sub> See report R56A25037B		
Systematic Capability (SC1, SC2, SC3, SC4)	SC3 See report (R56A25037B)		
Hardware safety integrity achieved	SIL 2 achieved for low demand with HFT=0 (1oo1)		

**Note 1:** The failure data:

- 1) Failure rates stated in the above tables are in units of failures per hour.
- 2) The PFD<sub>AVG</sub> figure shown is for illustration only assuming a proof test interval of 8760 hours and MTTR of 8 hours. Refer to IEC 61508-6 for guidance on PFD<sub>AVG</sub> calculations from the failure data.
- 3) The failure rates do not include no parts failures.

The failure data above is supported by the base information given in Table 3 below.



**Table 3: Information supporting the failure rate data**

1	Product identification:	1500 & 1600 Series 3/2 Single Pilot Operated Valves as described in manufacturer's product catalogue.
2	Functional specification:	To return the valve to a spring extended position when de-energised.
3	Environment limits:	Temperature range: -20 to +180°C Standard.
4	Lifetime/replacement limits:	Rotork Midlands have not specified a lifetime limit for their products, however it is envisaged that valves of similar specification along with regular maintenance and inspection could have a lifetime in excess of 20 years.
5	Proof Test requirements:	Refer to user manual - IOM-1500 & 1600
6	Maintenance requirements:	Refer to user manual - IOM-1500 & 1600
7	Diagnostic coverage:	N/A
8	Diagnostic test interval:	N/A
9	Repair constraints:	Refer to user manual - IOM-1500 & 1600
10	Evidence of similar conditions in previous use:	Compliance Route 2 <sub>H</sub> (proven-in-use) not used
11	Evidence supporting the application under different conditions of use:	Compliance Route 2 <sub>H</sub> (proven-in-use) not used
12	Evidence of period of operational use:	Compliance Route 2 <sub>H</sub> (proven-in-use) not used
13	Statement of restrictions on functionality:	Compliance Route 2 <sub>H</sub> (proven-in-use) not used
14	Systematic capability:	SC3 – See report R70055790B.
15	Systematic fault avoidance measures:	Refer to Systematic Assessment report R56A25037B.
16	Systematic fault tolerance measures:	Refer to Systematic Assessment report R56A25037B.
17	Validation records:	Refer to the hardware assessment report R56A25037B.

### Management of functional safety

The assessment has demonstrated that the product is supported by an appropriate functional safety management system that meets the relevant requirements of IEC 61508-1:2010 clause 6, see report R70055790B.

### Identification of certified equipment

A full list of certified equipment documents are defined in the table below:

Document no.	Pages	Rev	Date	Document description
SSVM 832B/6MV-Z	1	1	07/06/2005	¼" Stainless steel 316 3/2 spool valve single pilot solenoid operated (side mounted) – Spring return.
SSVM 832B/6MV-LH-K	1	1	9/09/1999	¼" Stainless steel 316 3/2 spool valve single pilot solenoid operated (side mounted) Left hand – Spring return.
SSVM 1532S/6MV-Z	1	1	09/06/2005	½" Stainless steel 316 3/2 spool valve single pilot solenoid operated – Spring return.



SSVM 1532S/6MV-LH-Z	1	1	30/07/2007	½" Stainless steel 316 3/2 spool valve single pilot solenoid operated – Left hand – Spring return
SPV2/1712KZ	1	1	10/06/2005	¼" Stainless steel 316 3/2 spool valve single pilot solenoid operated (side mounted) – Spring return. Aux. outlet from pilot chamber.
1323M23-SM-ZKD	1	2	17/12/2015	3 Way operator 24vDC Solenoid
1323M23-SM-ZKD	1	2	17/12/2015	3 Way operator 48vDC Solenoid
IP5441A	1	N/A	03/01/1996	T6 EEXD P.C.B Non-rectified
IP5442A	1	N/A	03/01/1996	T6 EEXD P.C.B Rectified
SSVM 832B/2NV	1	5	19/02/2015	¼" NPT stainless steel 316 3/2 spool valve single pilot operated – Spring return.
SSVM 1532S/2NV	1	3	09/08/2011	½" NPT stainless steel 316 3/2 spool valve single pilot operated – Spring return.

The following table lists all product codes and any associated drawings.

Product Code	Drawing Number	Rev	Description	Connection
4326M21-ES2B	SSVM1532S/2NEP	1	½ NPT LOW TEMP SS316 3/2 SPOOL VALVE PILOT OPERATED SPRING RETURN	1/2" NPT
4326M21-VR2B	SSVM 1532S/2NV	3	½ NPT SS316 3/2 SPOOL VALVE PILOT OPERATED SPRING RETURN	1/2" NPT
2326M21-ER2B	SSVM832B/2N-EP	1	¼ NPT LOW TEMP SS316 3/2 SPOOL VALVE PILOT OPERATED SPRING RETURN	1/4" NPT
2326M21-VR2B	SSVM 832B/2NV	5	¼ NPT SS316 3/2 SPOOL VALVE PILOT OPERATED SPRING RETURN	1/4" NPT
2326M23-VR5BK-	SSVM832B/6MV-K <sup>[1]</sup>	1	¼" Pilot Solenoid operated spool valve with Alcon Exd Solenoid Operator	¼" Manifold Mounted
2326M23-VR5LK-	SSVM832B/6MV-LH-K <sup>[1]</sup>	1	¼" LH Pilot Solenoid operated spool valve with Alcon Exd Solenoid Operator	¼" Manifold Mounted
4326M23-VS5BK-	SSVM1532S/6MV-K <sup>[1]</sup>	1	½" Pilot Solenoid operated spool valve with Alcon Exd Solenoid Operator	½" Manifold Mounted
4326M23-VS5LK-	SSVM1532S/6MV-LH-K <sup>[1]</sup>	1	½" LH Pilot Solenoid operated spool valve with Alcon Exd Solenoid Operator	½" Manifold Mounted
2326M23-S1712KZ	SPV2/1712KZ	1	¼" LH Pilot Solenoid operated spool valve with auxiliary outlet port	¼" Manifold Mounted

**Note:** The valve and solenoid may be shown as separate items on drawing parts lists as follows:

Drawing Number	Description	Connection
SSVM832B/6MV-Z	¼" Pilot Solenoid operated spool valve	¼" Manifold Mounted
SSVM832B/6MV-LH-Z	¼" LH Pilot Solenoid operated spool valve	¼" Manifold Mounted
SSVM1532S/6MV-Z	½" Pilot Solenoid operated spool valve	½" Manifold Mounted
SSVM1532S/6MV-LH-Z	½" LH Pilot Solenoid operated spool valve	½" Manifold Mounted
1323M23-SM-ZK-	Alcon Exd Solenoid Operator	N/A



**Sira Certification Service  
Part of CSA Group UK**

Unit 6 Hawarden Industrial Park,  
Hawarden, CH5 3US, United Kingdom.  
Tel: +44 (0) 1244 670900  
Email: [ukinfo@csagroup.org](mailto:ukinfo@csagroup.org)  
Web: [www.csagroupuk.org](http://www.csagroupuk.org)

## Conditions of Certification

The validity of the certified base data is conditional on the manufacturer complying with the following conditions:

1. The manufacturer shall analyse failure data from returned products on an on-going basis. Sira Certification Service shall be informed in the event of any indication that the actual failure rates are worse than the certified failure rates. (A process to rate the validity of field data should be used. To this end, the manufacturer should co-operate with users to operate a formal field-experience feedback programme).
2. Sira shall be notified in advance (with an impact analysis report) before any modifications to the certified equipment or the functional safety information in the user documentation is carried out. Sira may need to perform a re-assessment if modifications are judged to affect the product's functional safety certified herein.
3. On-going lifecycle activities associated with this product (e.g., modifications, corrective actions, field failure analysis) shall be subject to surveillance by Sira in accordance with 'Regulations Applicable to the Holders of Sira Certificates'.

## Conditions of Safe Use

The validity of the certified base data in any specific user application is conditional on the user complying with the following conditions:

1. Selection of this equipment for use in safety functions and the installation, configuration, overall validation, maintenance and repair shall only be carried out by competent personnel, observing the manufacturer's conditions and recommendations in the user documentation.
2. All information associated with any field failures of this product should be collected under a dependability management process (e.g., IEC 60300-3-2) and reported to the manufacturer.
3. A proof test interval of 1 year.

## General Conditions and Notes

1. This certificate is based upon a functional safety assessment of the product described in Sira Test & Certification Assessment Reports R70055790A, R56A25037B & R56A25037A.
2. If the certified product is found not to comply, Sira Certification Service should be notified immediately at the address shown on this certificate.
3. The use of this Certificate and the Sira Certification Mark that can be applied to the product or used in publicity material are subject to the 'Regulations Applicable to the Holders of Sira Certificates' and 'Supplementary Regulations Specific to Functional Safety Certification'.
4. This document remains the property of Sira and shall be returned when requested by the issuer.
5. No part of the Functional safety related aspects stated in the installation instructions shall be changed without approval of the certification body.
6. This certificate will remain valid subject to completion of two surveillance audits within the five year certification cycle, and upon receipt of acceptable response to any findings raised during this period. This certificate can be withdrawn if the manufacturer no longer satisfies scheme requirements.



## Sira Certification Service Part of CSA Group UK

Unit 6 Hawarden Industrial Park,  
Hawarden, CH5 3US, United Kingdom.  
Tel: +44 (0) 1244 670900  
Email: [ukinfo@csagroup.org](mailto:ukinfo@csagroup.org)  
Web: [www.csagroupuk.org](http://www.csagroupuk.org)

## Certificate History

Issue	Date	Project No.	Comment
03	04/02/2016	70055790	Revision 3 of this certificate to include a range of solenoid operated product variants.
04	16/02/2017	70113700	Re-issue of certificate post successful recertification.

