

### Description

TBT-...-U-immersion thermostats monitor, limit and regulate the temperature for non-aggressive gases and liquids. In combination with the switching amplifiers with intrinsically safe circuits, the immersion thermostats may be used within hazardous areas of zones 1 and 2.

The device is maintenance-free.

**ATEX-compliant for zone 1 and 2 according to ATEX Directive 2014/34/EU.**



(Fig. similar)

### Delivery program

Type	Product No.	Adjustment range	Gear shift difference
<b>Standard</b>			
TBT-2G-0-90-U	057.1430	0 ... 90 °C, inside	3 K
TBT-2G-0-120-U-TW	057.1437	0 ... 120 °C, inside	3 K
<b>Remote sensors</b>			
TBT-FF-2G-0-90-U	057.1445	0 ... 90 °C, inside	3 K
TBT-FF-2G-0-120-U	057.1446	0 ... 120 °C, inside	3 K
<b>Stainless steel</b>			
TBT-VA-2G--35-+35-U	057.1435	-35 ... +35 °C, inside	3 K
TBT-VA-2G-0-120-U	057.1453	0 ... 120 °C, inside	3 K
TBT-VA-2G-0-90-U	057.1452	0 ... 90 °C, inside	3 K

### Intrinsic

Simple electrical equipment according to IEC/EN 60079-11, Section 5.7, suitable for zone 1 and 2. Only for connection to intrinsically safe circuits.

The specified values at the terminals must not be exceeded.

$U_o \leq U_i$	$9.6 \text{ V} \leq 30 \text{ V}$
$I_o \leq I_i$	$10 \text{ mA} \leq 50 \text{ mA}$
$P_o \leq P_i$	$24 \text{ mW} \leq 100 \text{ mW}$
$C_o \geq C_i + C_{\text{Cable}}$	$C_i = 0 \text{ } \mu\text{F}$
$L_o \geq L_i + L_{\text{Cable}}$	$L_i = 0 \text{ } \mu\text{H}$
$C_{\text{Cable}}, L_{\text{Cable}}$ : see the specifications of the cable manufacturer	
$C_o, L_o$ : see the documentation for the switching amplifier according to the gas group	

### Technische Daten

<b>Supply</b>		Via switching amplifier EXL-IR-9170
<b>Contact</b>		Dust-encapsulated microswitch as a single-pole, potential-free changeover switch
<b>Measuring medium</b>		Gaseous, liquid, non-aggressive
<b>Ambient</b>		-10 ... +65 °C
<b>Storage temperature</b>		-20 ... +80 °C
<b>Bezel material</b>		Plastic, PA glass ball reinforced
<b>Sensor material</b>	TBT-VA-2G--35-+35-U TBT-VA-2G-0-120-U TBT-VA-2G-0-90-U	Stainless steel 1.4571 (V4A), d = 9 mm
	TBT-2G-0-90-U TBT-2G-0-120-U-TW TBT-FF-2G-0-90-U TBT-FF-2G-0-120-U	Brass (optional stainless steel), d = 8 mm
<b>Safety class</b>		Simple electrical equipment according to EN 60079-11
<b>Installation length EL</b>	TBT-VA-2G--35-+35-U TBT-2G-0-120-U-TW	120 mm
	TBT-2G-0-90-U TBT-VA-2G-0-120-U	130 mm
	TBT-FF-2G-0-90-U TBT-FF-2G-0-120-U TBT-VA-2G-0-90-U	150 mm
<b>Protection class according to EN 60529</b>		IP65 (Brass), IP54 (VA), IP20 (TBT-FF)
<b>Dimensions (W×H×D)</b>		108 × 73.5 × 70 mm
<b>Weight</b>	TBT-VA-2G--35-+35-U	300 g
	TBT-2G-0-120-U-TW	372 g
	TBT-FF-2G-0-90-U TBT-FF-2G-0-120-U TBT-2G/0-120-U/130-VA TBT-VA-2G-0-90-U	500 g
	TBT-VA-2G-0-90-U	504 g
<b>Included</b>		Thermostat

### Installation and operation

#### Safety instructions

All relevant national and international standards and regulations for hazardous areas must be observed. Equipment must be installed in accordance with the manufacturer's instructions. If the device is used in a manner different from that specified by the manufacturer, the safety level of the device may be reduced. EN/IEC 60079-14 can be used for the design, selection and construction of electrical systems.

- Intrinsically safe circuits are designed in such a way that the energy content is below the minimum level that would be required to cause ignition of an explosive atmosphere in the event of a spark occurring.
- Intrinsically safe circuits are shown in light blue and are to be laid separately from non-intrinsically safe circuits.
- The intrinsically safe sensor is passive, potential-free and approved for zones 1 and 2.
- Observe the maximum connection values during instrumentation.
- De-energise before assembly and disassembly.
- Close all openings. Ensure IP protection.
- Operate the immersion thermostat only with the supplied immersion sleeve to ensure the accuracy of response.
- Use thermal grease to ensure the accuracy of response.
- Clean with damp cloth only. Avoid electrostatic charging. Remove dust deposits.
- Observe separate documentation:
  - Switching amplifiers

#### Location and installation

Select the installation location so that the error due to heat dissipation remains within the permissible error limits and the max. ambient temperature is not exceeded.

The device can be mounted in any position.

For wall mounting, the two holes in the housing can be used.

**Open the device:** Loosen the two screws in the lid.

**After installation:** Tighten all screws and cable entry firmly.

#### Function

**Heating:** The set setpoint (scale value) corresponds to the switch-off value of the heater. The switch-on value is lower by the switching difference. Contact 2 - 3 opens when the temperature rises to the set setpoint.

**Cooling:** The set setpoint (scale value) corresponds to the switching-off value of the cooling. The switch-off value is lower by the switching difference. Contact 2 - 1 closes when the temperature rises to the set setpoint.

#### Recommended switching amplifier

- Ex-i switching amplifier from Company Stahl type EXL-IR-9170-11-12-11s
- When using the sensor together with a switching amplifier recommended by us, the intrinsic safety for simple circuits is proven
- Manufacturer's certificate for zone 1, 2

### Electrical connection

The electrical connection is made according to the operating instructions of the switching amplifier.

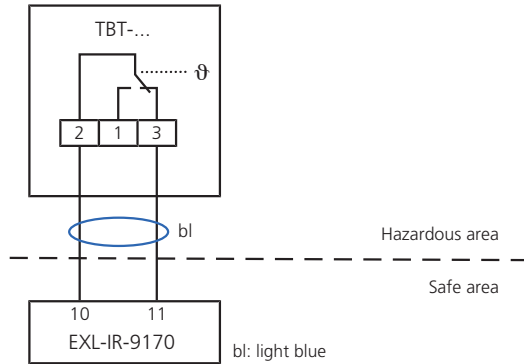

### Dimensions

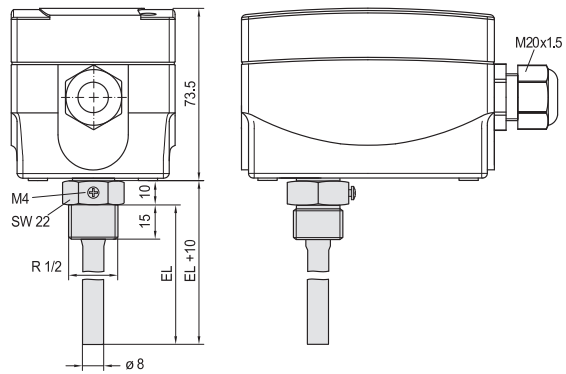
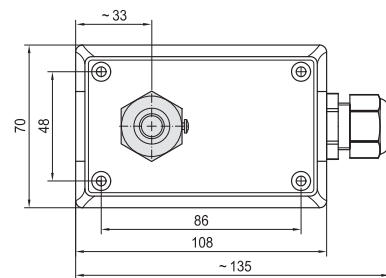
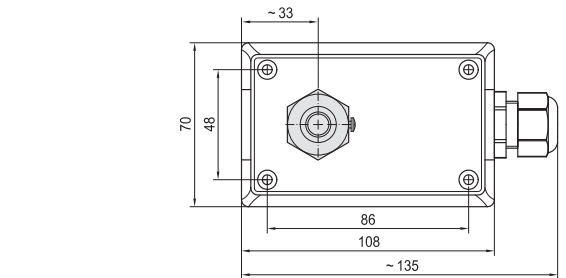

TBT-2G 0/90-U (all measurements in mm)

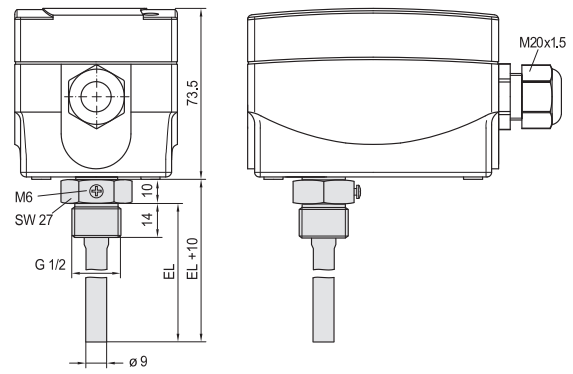

TBT-VA-2G -35/35-U (all measurements in mm)

We, the
Schischek GmbH Mühlsteig 45 Business Park South 5 90579 Langenzenn GERMANY
declare under sole responsibility in accordance with the provisions of the guidelines:
2014/34/EU
that the product
TBT-...-U-2G
to which this declaration refers, complies with the following norms or normative documents:
EN 60079-11:2012      EN IEC 60079-0:2018+AC:2020-02
Marking:
<b>CE</b> Zone 1, Zone 2 Simple resources
Managing:
 (Dr. Sven Ludwig)
90579 Langenzenn, 2024-09-01

## Manufacturer's declaration for sensors for use in hazardous areas

<b>Item</b>	Immersion thermostat	<b>Manufacturer</b>	Schischek GmbH
<b>Type</b>	TBT-...-U-2G	<b>Property</b>	Passive, potential-free
<b>Installation in</b>	Zone 1, 2	<b>Associated equipment</b>	EXL-IR-9170-11-12-11s

### Test goal

The immersion thermostat has been tested for suitability for installation and operation in hazardous areas of zones 1 and 2. The test is based on Directive 2014/34/EU (ATEX). The standards applied are EN 60079-0 and EN 60079-11. The immersion thermostat is a simple electrical device in the sense of EN 60079-11 Section 5.7 and must be operated via a special electrical circuit. The switching amplifier EXL-IR-9170-11-12-11s from Company Stahl is suitable. The switching amplifier may only be installed and operated in non-hazardous areas.

### Proof of intrinsic safety for simple circuits in use with EXL-IR-9170-11-12-11s

$U_o \leq U_i$	$9.6 \text{ V} \leq 30 \text{ V}$
$I_o \leq I_i$	$10 \text{ mA} \leq 50 \text{ mA}$
$P_o \leq P_i$	$24 \text{ mW} \leq 100 \text{ mW}$
$C_o \geq C_i + C_{\text{Cable}}$	$C_i = 0 \text{ }\mu\text{F}$
$L_o \geq L_i + L_{\text{Cable}}$	$L_i = 0 \text{ }\mu\text{H}$
$C_{\text{Cable}}, L_{\text{Cable}}$ : see the specifications of the cable manufacturer	
$C_o, L_o$ : see the documentation for the switching amplifier according to the gas group	

Test	Result
IP protection	The device meets at least IP65 (standard), IP54 (stainless steel), IP20 (remote sensor)
Inspection of metallic housing parts	Magnesium, titanium and zirconium content < 7.5%
Checking plastic	Suitable in the used ambient temperature range -10 °C ... +65 °C
Electrostatics	Can be used without restriction in groups IIA and IIB, for group IIC the warning "Wipe only with a damp cloth" applies
Locks and latches	Not to comply with special conditions, not relevant
Grounding (potential equalisation)	Double insulation, no PE, PA necessary
Cable and cable entries	The cables must be protected from mechanical and thermal stress, after installation, min. IP65 (standard), IP54 (stainless steel) must be fulfilled
Temperature testing	Together with the switching amplifier EXL-IR-9170-11-12-11s a temperature increase of <5 K was measured in the event of an error; operating temperature range: -10 °C ... +65 °C

### Overall rating/additional comments

The immersion thermostat type TBT-...-U-2G can be used in conjunction with the switching amplifier EXL-IR-9170-11-12-11s from Company Stahl in zones 1 and 2. The information in the data sheet or the operating instructions must be observed. The warnings regarding electrostatic charging must also be observed. After installation, at least the protection class IP65 (standard), IP54 (stainless steel), IP20 (remote sensor) must be guaranteed.



Langenzenn, 01. Sept. 2024  
 Wen Liu  
 Explosion Protection Officer

**SCHISCHEK**  
 A ROTORK Brand

Contact us now

mail@rotork.com  
 www.rotork.com

**rotork®**

PUB113-426-00  
 Issue 03/25