



Keeping the World Flowing  
for Future Generations

### Features and Benefits

- Control sensitivity of 1" water column allows use in precision applications
- Large Supply and Exhaust Valves provide high forward and exhaust flows
- Soft supply and exhaust valve seats minimize air consumption
- A balanced supply valve minimizes the effect of supply pressure variation
- An aspirator tube compensates downstream pressure droop under flow conditions
- A separate control chamber isolates the diaphragm from the main flow to eliminate hunting and buzzing
- Unit construction lets you service the Model 1500A without removing it from the line

### Operating Principles

The output of the relay is the sum of the spring bias, set with the range screw, plus a pneumatic input signal. ( $P_o = P_s + K$ ); where  $P_o$  is output pressure,  $P_s$  is signal pressure, and  $K$  is the spring constant set by the range screw. The signal pressure exerts a force against the top of the signal diaphragm that creates a downward force on the diaphragm assembly and opens the supply valve. Output pressure flows through the outlet port and the aspirator tube to the control chamber where it creates an upward force on the bottom of the control diaphragm.

When the setpoint is reached, the forces of the signal pressure and the range spring that act on the top of the signal diaphragm, balance with the force of the output pressure that acts on the bottom of the control diaphragm to close the supply valve.

When the output pressure increases above the setpoint, the diaphragm assembly moves upward to close the supply valve and open the exhaust valve. Because the poppet valve is closed, pressure flows down the control tube to the bottom of the motor diaphragm. This pressure keeps the supply valve tightly closed while in the exhaust mode. The poppet valve opens and excess output pressure exhausts through the vent in the side of the unit until it reaches the setpoint.



## Model 1500A Positive Bias Relay

### Specifications

#### Supply Pressure

- 250 psig, [17.0 BAR], (1700 kPa) Maximum

#### Flow Capacity (SCFM)

- 150 (255 m<sup>3</sup>/HR) @ 100 psig, [7.0 BAR], (700 kPa) supply and 20 psig, [1.5 BAR], (150 kPa) setpoint

#### Exhaust Capacity (SCFM)

- 40 (68 m<sup>3</sup>/HR) where downstream pressure is 5 psig, [.35 BAR], (35 kPa) above 20 psig, [1.5 BAR], (150 kPa) setpoint

#### Signal or Output Pressure

- 150 psig, [10.0 BAR], (1000 kPa) maximum

#### Supply Pressure Effect

- Less than 0.1 psig, [.007 BAR], (.7 kPa) for 100 psig, [7.0 BAR], (700 kPa) change in supply pressure

#### Sensitivity

- 1" (2.54 cm) water column

#### Ambient Temperature

- -40 to +200 °F, (-40 to +93 °C)

#### Materials of Construction

- Body and Housing: Aluminum  
Diaphragms: Nitrile on Dacron  
Trim: Zinc Plated Steel, Brass



### Dimensions

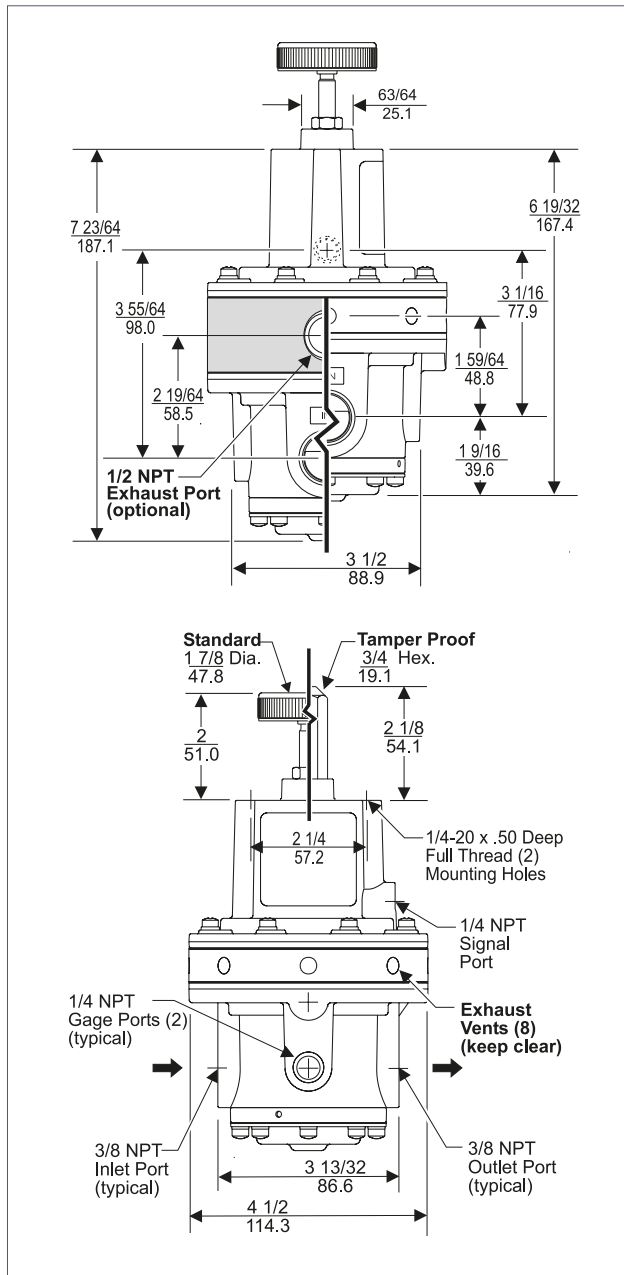

### Product Code

15 2 3 A E

#### Pressure Range

	psig	[BAR]	(kPa)
2	= 0-10	[0-0.7]	(0-70)
3	= 0.5-30	[0.03-2]	(3-200)
4	= 1-60	[1-4.0]	(10-400)
6	= 2-150	[0.15-10]	(15-1000)

#### Pipe Size

3	= 3/8" NPT
4	= 1/2" NPT
6	= 3/4" NPT

#### Options

- E = Tapped Exhaust
- H = BSPP<sup>1</sup>
- T = Tamper Proof
- U = BSPT (Tapered)

<sup>1</sup> BSPP Threads in Inlet and Outlet Ports only. Others BSPT.

### Flow Characteristics (Model 1564A1)

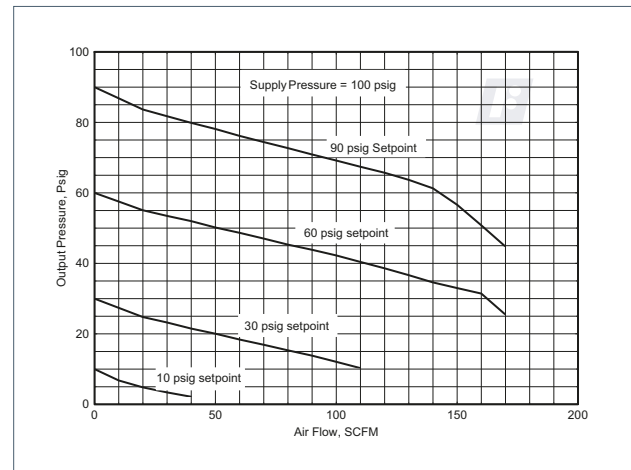

### Mounting Bracket

P/N 20555-1 (sold separately)

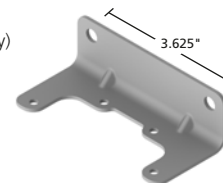

For installation instructions, refer to the Fairchild Model 1500A Positive Bias Relay Installation, Operation and Maintenance Instructions, IS-3001500A.

A full listing of the Rotork sales and service network is available on our website.

[www.rotork.com](http://www.rotork.com)

PUB103-071-00  
Issue 09/20

Rotork plc, Bath, UK  
tel +44 (0)1225 733200  
email mail@rotork.com

Fairchild Industrial Products  
3920 West Point Blvd  
Winston-Salem, NC 27103  
tel +1 (336) 659-3400  
fax +1 (336) 659-9323  
email: US-VS-CS@Rotork.com