

rotork®

Keeping the World Flowing
for Future Generations

K-TORK range Installation & maintenance instructions

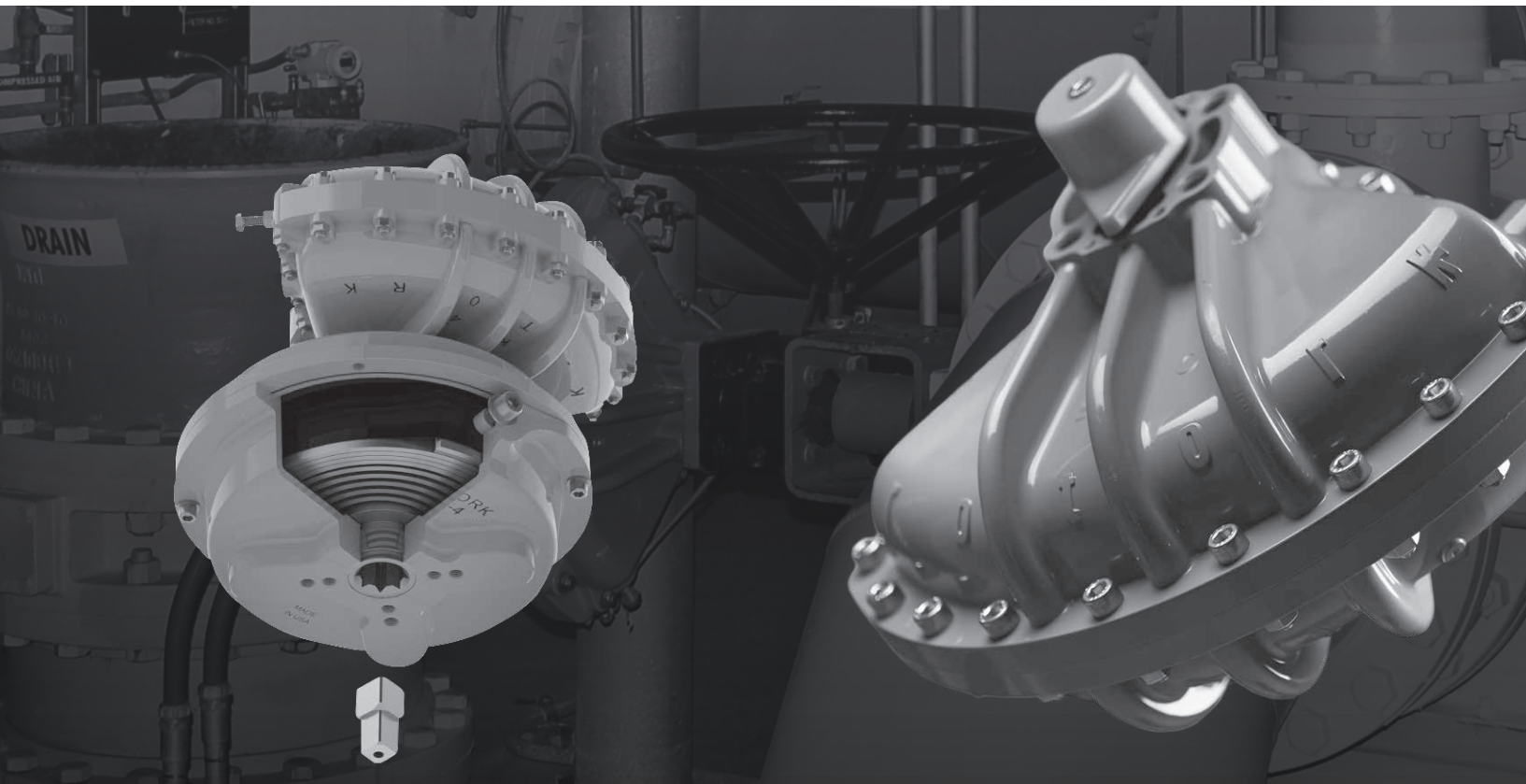

High-performance quarter-turn / rotary pneumatic actuators

Contents

Section	Page	Section	Page
1. Introduction	3	10. Installation on valve and earthing	10
2. Standards and regulations	4	10.1 Preliminary actions	10
3. General information	4	10.2 Instructions	10
4. Health and safety	5	11. Actuator removal from the valve	11
4.1 Residual risks	5	12. Operation	12
4.2 Thermal risks	5	12.1 Actuator description	12
4.3 Noise	5	12.2 Setting the actuator angular stroke	14
4.4 Health risks	5	12.3 Power supply	16
4.5 Mechanical risks	5	12.4 Pneumatic connections	16
5. Labels and nameplates	6	12.5 Electrical connections	16
6. Operating limits	7	12.6 Start-up	17
6.1 Allowed fluid types	7	12.7 Speed adjustment	17
6.2 Expected lifetime	7	13. Dismantling and disposal	18
7. Handling and lifting	8	14. Rotork sales and service	18
7.1 Lifting recommendations	8	15. Troubleshooting	19
7.2 Lifting instructions	8	16. Periodic maintenance	20
8. Storage	9	16.1 Periodic inspections	20
9. Long-term storage	9	16.2 Pneumatic actuator seals replacement	21

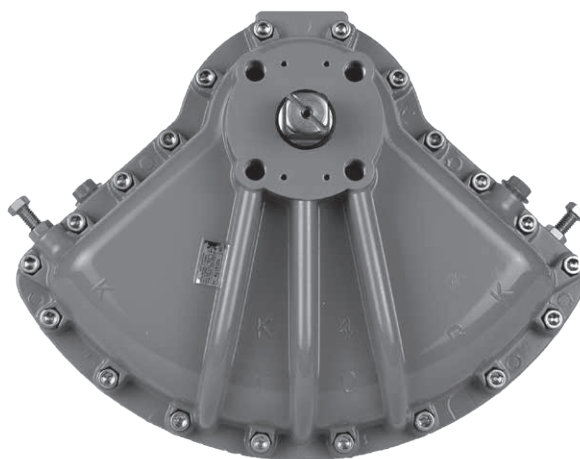

This manual contains important safety information. Please ensure it is thoroughly read and understood before installing, operating or maintaining the equipment.

Rotork reserves the right to modify, amend and improve this manual without notice.

Rotork is not responsible for damage or injury caused by the failure to observe the instructions contained herein.

1. Introduction

Rotork designs, manufactures, and tests its products to meet many national and international standards. For these products to operate within their normal specifications, they must be properly installed and maintained.

The following instructions must be followed and integrated with your safety programme when installing and using Rotork products:

- Read and save all instructions prior to installing, operating and servicing this product.
- If you don't understand any of the instructions, contact Rotork for clarification
- Follow all warnings, cautions and instructions marked on, and supplied with, the product.
- Inform and educate personnel in the proper installation, operation and maintenance of the product
- Install equipment as specified in Rotork installation instructions and per applicable local and national codes. Connect all products to the proper electrical sources
- To ensure proper performance, use qualified personnel to install, operate, update and maintain the unit
- When replacement parts are required, ensure that the qualified service technician uses replacement parts specified by Rotork. Substitutions may result in fire, electrical shock, other hazards, or improper equipment operation
- Keep all product protective covers in place (except when installing, or when maintenance is being performed by qualified personnel), to prevent electrical shock, personal injury or actuator damage
- Operation of actuator in an inappropriate fashion may cause harm or damage to unit or other equipment surroundings

This manual covers maintenance aspects and instructions specific to the K-TORK range of actuators. General information on Rotork actuators are described in the user manual, delivered separately.

In this manual, warning indications are represented by icons, according to ISO 7010 Safety Signs.



Generic danger



Hand crush/pinch point



Electrocution



Explosive material

Customer service

For technical assistance, please contact Rotork customer service:

E-mail: rfs.international@rotork.com

Rotork, Via Padre Jacques Hamel, 138B, Porcari, Lucca, 55016, IT. Tel: +39 0583-222-1

Rotork plc, Brassmill Lane, Bath, UK. Tel +44 (0)1225 733200

Preservation

This manual is considered an integral part of the actuator and must be kept along with it until the actuator is decommissioned.

This manual and all the attached documentation are to be preserved, kept in a suitable and accessible place and available at all times to the maintenance operators for consultation.

This manual shall always accompany the actuator, even when the actuator is moved to another plant.

Should the manual be lost or damaged, please contact Rotork to get a copy, providing the manual document number for reference or download a copy from www.rotork.com.

2. Standards and regulations

Actuators destined for European member states and for the United Kingdom have been designed, built and tested according to the quality control system, in compliance with the EN ISO 9001:2015 and with the following regulations/directive and standards:

- 2006/42/EC: Machinery Directive (MD)
- S.I. 2008 No. 1597: The Supply of Machinery (Safety) Regulations 2008
- 2014/68/EU: Pressure Equipment Directive (PED)
- S.I. 2016 No.1105: Pressure Equipment (Safety) Regulations 2016 (PE(S)R)
- 2014/34/EU: Directive for safety equipment and systems to be used in potentially explosive atmospheres (ATEX)
- S.I. 2016 No. 1107: The Equipment and Protective Systems Intended for Use in Potentially Explosive Atmospheres Regulations 2016
- 2014/30/EU: Electromagnetic Compatibility Directive (EMC)
- S.I. 2016 No. 1091: Electromagnetic Compatibility Regulations 2016
- BS EN ISO 12100: Machinery Safety Directive
- BS EN 60079-14: Explosive atmospheres - Part 14: Electrical installations design, selection and erection
- BS EN 1127-1: Explosive atmospheres - Explosion prevention and protection - Basic concepts and methodology
- BS EN ISO 80079-36: Non Electrical equipment for explosive atmospheres - Basic methods and requirements
- BS EN ISO 80079-37: Non-electrical equipment for explosive atmospheres - Non-electrical type of protection construction safety "c", control of ignition "b", liquid immersion "k"
- IEC 60079-46: Explosive atmospheres - Part 46: Equipment assemblies
- BS EN ISO 7010: Safety Signals
- BS EN 13445: Unfired Pressure Vessel

3. General information

This manual is produced to enable a competent user to install, operate and maintain the Rotork K-TORK actuator single- and double-acting (KT-XX-SR and KT-XX-DA).

The mechanical installation must be carried out as outlined in this manual and in accordance with any relevant national standard codes of practice.

Maintenance and operation must be carried out in accordance with the National Legislation and Statutory Provisions relating to the safe use of this equipment, applicable to the site of installation.

Any inspection or repair in a hazardous area must not be undertaken unless it conforms to National Legislation and Statutory Provisions relating to the specific hazardous area.

Only Rotork approved replacement parts should be used. Under no circumstances should any modification or alteration be carried out on the equipment, as this could invalidate the conditions under which its certification was granted.

Only trained and experienced operators can install, maintain and repair Rotork actuators. Work undertaken must be carried out in accordance with instructions in this manual. The user and those persons working on this equipment must be familiar with their responsibilities under any statutory provisions relating to the health and safety of their workplace.

Operators must always wear appropriate Personal Protective Equipment (PPE) in line with the existing plant regulations.

Appropriate usage

Rotork K-TORK range actuators have been specifically developed to automate quarter-turn valves, such as ball valves, butterfly valves or plug valves installed on pipelines for oil & gas transport and distribution.

⚠ Improper use can damage the equipment or cause dangerous situations for health and safety. Rotork declines any responsibility for damage to people and/or objects resulting from the use of the equipment for applications different from those described in the present manual.

⚠ Hazardous area usage: Only use devices approved for hazardous area use. These devices will have an EX type label fixed to them. Before installation and operation in a potentially explosive atmosphere, read and follow the information and instructions on the EX label and any additional EX instructions in the documentation received with the device.

4. Health and safety

Before installing the equipment, verify it is suitable for the intended application. If unsure consult Rotork.

4.1 Residual risks

Residual risks resulting from equipment risk evaluation performed by Rotork.

4.2 Thermal risks

Risk Hot/cold surface during normal operation (RES_01).
Preventive measures Operators should wear protective gloves.

4.3 Noise

Risk Noise >85 dB during operation (RES_05).
Preventive measures Operators should wear ear protections. Operators should not stand near the equipment during operation.

4.4 Health risks

Risk Pressurised fluid ejection during normal operation (RES_02).
Preventive measures All fittings must be properly sealed. All fixing clamps must be correctly tightened and sealed.
Risk Risk of intoxication (according to the type of medium utilised) (RES_06).
Preventive measures Operators must use PPE and any other equipment (breathing apparatus) based on the type of supply medium.

4.5 Mechanical risks

Risk Uncontrolled movement (remote operation) (RES_03). (This risk is applicable only for actuators provided with control panel).
Preventive measures Assure that the actuator can not be operated remotely. Prior to starting, remove pneumatic supply, vent all pressure vessels, and remove electrical power.
Risk Presence of moving parts (centre body, valve adapter) (RES_04)
Preventive measures Do not perform start-up or test the actuator if the cylinder tube is removed.

Risk Loss of stability with possible parts projection (RES_08).
Preventive measures Do not disassemble the actuator in case of malfunctioning. Follow instructions in the present manual and contact Rotork.
Preventive measures Foresee periodic maintenance procedure to verify tightening.
Risk Presence of potential energy (RES_10) during dismantling.
Preventive measures Do not disassemble the actuator during dismantling. Follow instructions in the present manual and contact Rotork.

5. Labels and nameplates

The actuator body is cast-embossed with the manufacturer's name and the model's name. Each actuator is delivered with a standard label.

For actuators delivered within the European Union, the CE mark the product conformity with the essential applicable health and safety requirements of the European Directives.

Supplementary nameplates are applied externally on the centre body cover and displays the following data:

- CE conformity marking
- ATEX protection
- Name of technical file deposited with a certifying body

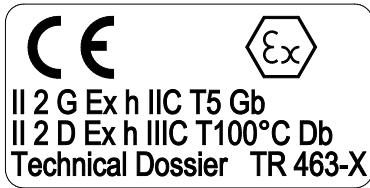

Figure 1: CE ATEX nameplate

EX type of protection: constructional safety "c".

T5 temperature class is provided even if actuator has no internal heat source. The maximum actuator temperature is near the environmental or exercise fluid temperature, whichever is the greater. The normal operating temperature range is -20 to +80 °C (-22 to +176 °F). The temperature range is specified within the project-specific technical documentation. Special applications out of the normal range are available upon request.

EX plate does not indicate the maximum environmental and/or exercise fluid temperature; this information is reported within the project specific technical documentation.

Contents of the standard nameplate:

- Name and address of the manufacturer
- Model type
- Serial number
- Month/year of manufacture
- Maximum/minimum operating pressure (bar)
- Maximum/minimum operative temperature (°C)
- IP protection class

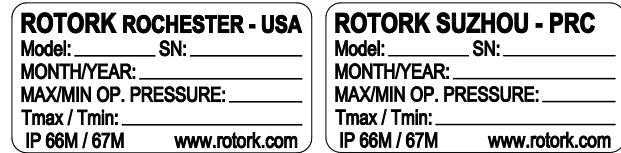

Figure 2: KT-XX-DA/ISR standard nameplate for units made in USA and China

If CE (PED) marking is required, the following data is specified on a third plate:

- CE conformity marking
- PED 97/23/CE category
- Fluid
- Design pressure PS (bar)
- Testing pressure PT (bar)
- Design temperature TS (°C)
- Volume (litres)
- Certifying body number if applicable

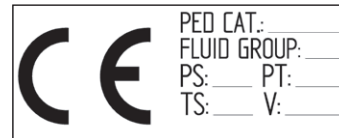

Figure 3: KT-XX-DA/ISR actuator PED nameplate

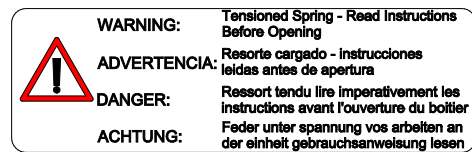

Figure 4: Spring housing warning nameplate

Please check if the data stamped on the plate coincide with those specified on the Confirmation of Order, Test Certificates and the Delivery Note.

Ensure that the product specification as noted on the nameplate(s) is suitable for the application.

⚠ It is not allowed to remove or modify the nameplate(s). The nameplate must be kept legible at all times: it must be regularly cleaned. In case the nameplate is damaged and illegible, a duplicate is to be requested.

6. Operating limits

Operating temperature

K-TORK actuators are built with two seal options, referred to as high and low temperature builds, suitable for the following operating temperature ranges:-

High Temperature (HT): -20 to +149 °C (0 to +300 °F)

Low Temperature (LT): -40 to +70 °C (-40 to +160 °F)

Both build options are suitable for standard operating temperature ranges, -20 to +70 °C (0 to +160 °F).

A specific build option is only required for low and high temperatures where the operating conditions are outside this range.

Please contact Rotork for further details, and to confirm operating temperature range at required design point.

Operating pressure

Sizes KT-02 to KT-06: 2 to 7 bar (30 to 100 psi) range, 7 bar (100 psi) maximum working pressure, 10 bar (150 psi) maximum overload pressure.

Sizes KT-10 to KT-70: 2 to 10 bar (30 to 150 psi) range, 10 bar (150 psi) maximum working pressure, 15 bar (220 psi) maximum overload pressure.

⚠ Do not use the equipment outside its operating limits. Verify operating limits on the nameplate.

Prevent external surface temperature to reach the ignition point in potentially explosive environments.

The actuator surface temperature is strictly dependent on the temperature of the process fluid used and by the irradiation's conditions. The end-user must check the surface temperature of the assembly, so that this cannot go over the minimum gas ignition's temperature, which classifies the area with the explosion's risk.

Dust and debris accumulated on the actuator will slow down its cooling and contribute to the increase of its external temperature.

6.1 Allowed fluid types

The pneumatic actuator is designed to be operated with inert gas, instrument air with particles filtering = 40 µm (Class 7 according to ISO 8573-1, Table 1), pressure dew point= -20 °C or, at least, 10 °C below the ambient temperature (Class 3 according to ISO 8573-1, Table 2), total concentration of oil = 5 mg/m³ (Class 4, according to ISO 8573-1, Table 3); if not differently specified in specific project documentation.

6.2 Expected lifetime

Actuators are designed for a minimum of two million operations.

7. Handling and lifting

⚠ Only trained and experienced personnel should handle/lift the actuator.

The actuator is supplied packed on pallets suitable for normal handling.

⚠ Handle the actuator with care. Never stack pallets.

7.1 Lifting recommendations

- The lifting device and the sling must be suitably rated for the actuator weight and dimensions
- Do not use damaged sling(s)
- The sling must not be shortened with knots or bolts or any other makeshift device
- For lifting purposes, use only suitable lifting tools
- Do not drill holes, weld eye bolts or add any other type of lifting device on the actuator external surface
- Do not lift the actuator and valve combination with the actuator lifting lugs
- Every assembly must be estimated separately for a safe and correct lifting
- Avoid pulls or abrupt movements during lifting. Avoid pushing the load
- During lifting operations, do not handle the slings and/or the actuator

⚠ Do not step underneath suspended load.

7.2 Lifting instructions

NOTE: Indication of weight, centre of gravity, lifting points are reported within specific project documentation.

For non-horizontal actuator orientation, please consult project specific documentation before lifting.

- Prior to lifting the actuator, remove electrical power and vent all pressure vessels (if present)

For KT-30-SR, KT-40-SR, KT-50-DA, KT-60-DA and KT-70-DA models, lift the actuator using appropriate chain or sling attached to the eyebolt lifting interface, situated on the top side of the actuator as shown in Figure 5. The eyebolts have to be selected according to the threads on the eyebolt interface. Eyebolt is not supplied with actuator.

Adjust the chain and/or the textile sling so that the actuator remains horizontal.

- The lifting device and the sling must be suitable rated for the actuator weight and dimensions
- The sling must be in a proper working condition at all times to prevent injuries and/or accidents. Do not use a damaged sling
- The sling must not be shortened with knots or bolts or any other makeshift device
- In no circumstances should piping or electric cabling be used for lifting purposes. Drilling holes, welding eye bolts or adding any other type of lifting device on the actuator external surface is strictly forbidden
- Do not lift the actuator/valve assembly by the actuator. Only lift the actuator/valve assembly using the valve lifting lugs
- The actuator must be cut off from any source of energy
- Avoid abrupt movements during lifting. Do not push or pull the load when suspended
- During lifting operations, do not handle the slings and/or the actuator

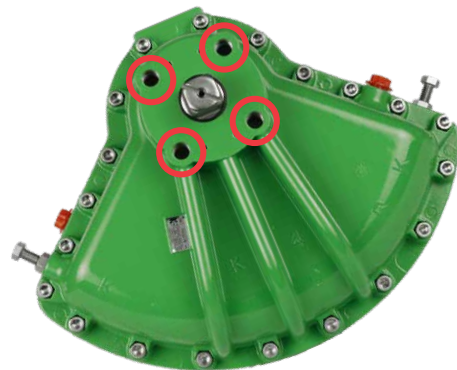

Figure 5: Actuator lifting points, highlighted by red circles.

⚠ The actuator must remain horizontal; balance the load.

8. Storage

Every Rotork actuator has been fully tested before leaving the factory to give years of trouble free operation, provided that it is correctly commissioned, installed and sealed.

To keep actuators in a good condition until they are installed, Rotork recommends the following measures during storage:

- Ensure that the dust plugs are properly fitted to any open fluid and electrical connections in order to prevent debris from entering into the system during transport and/or storage.
- The actuators are supplied on wooden pallets. They must remain on the pallets until they are installed, in order to prevent damage to the valve coupling flange.

Never put the actuator directly on the ground.

- It is recommended to store actuators in a dry place, providing appropriate protection against direct effects of weather.
- Check the actuator condition every 6 months and verify the above protection measures remain in place.

Remove package only at the installation time.

Actuator vent ports must be protected with polyethylene sheet to prevent water ingress during storage.

9. Long-term storage

If long-term storage is necessary, further operations must be carried out to maintain the actuator in good working condition, namely:

- Replace the plastic plugs by metal plugs to guarantee a complete weatherproof protection of the fluid and electrical connections, especially if the storage is outdoors
- The actuator must be stroked every 12-months, using filtered, dehydrated air
 - Connect the pneumatic supply and electric power (if present) to the actuator, according to the proper operating diagram and wiring diagram reported in the documentation of the specific project
 - Cycle the actuator at 80 psi (5.5 bar)
 - Utilising the actuators control components, cycle the actuator at least five times (i.e. five open strokes, five close strokes)
 - For actuators fitted with a mechanical manual override, cycle the actuator by means of the handwheel at least four times (i.e. four open strokes, four close strokes)
 - Subsequently disconnect the pneumatic and electric (if present) supply from the actuator, and carefully re-plug any open fluid and electrical connections
- Remove the covers from the electric components (if present), and ensure the terminals are clean and free from oxidation and humidity. Reassemble the covers.
- In case of storage for over 12 months, confirm proper operation prior to installation

10. Installation on valve and earthing

Before proceeding, read and understand the Health and Safety information.

NOTE: The valve must be properly secured prior to performing the following operations according to instructions provided by the valve's manufacturer.

⚠️ Prior to performing any operations check the operating drawings and TAG numbers.

Consult Rotork for any additional information.

10.1 Preliminary actions

⚠️ Verify the EX classification of the actuator is compatible with the plant zoning. Refer to actuator nameplate. The end user shall guarantee the valve earthing and the equal voltage potential between the valve and the actuator.

The assembling of the actuator onto the valve can be performed by using an adapter and a coupling joint between the actuator and the valve. The bracket utilised to interface the actuator and valve (damper, or other quarter-turn device) must be designed with close tolerance that permits near perfect concentric alignment between the center axes of the actuator shaft and driven shaft of the device being automated.

K-TORK range actuators can be mounted on valves in almost any desired position.

Important: To function properly, certain accessory and control components e.g. filter drains, pneumatic reservoirs; require proper orientation with respect to gravity. Contact Rotork if in doubt.

- Ensure that all fasteners are adequately tightened to avoid loosening during normal operation, take into account the vibrations induced by the dynamics of the pipeline
- All tubing used to provide pneumatic power to the actuator must be free from contaminants and debris
- Ensure tubes are adequately fastened and supported to minimize repetitive stress induced the dynamics of the pipeline
- Ensure there are no leaks from any pneumatic connections. Tighten as required

⚠️ Improper adaptation of the bracket and coupling to the actuator can cause unnecessary friction and premature failure. Misalignment can certainly lead to poor performance and inaccurate control.

10.2 Instructions

The vane floats on its spring-loaded seals inside actuator housings. Avoid all end loading to the actuator shaft. End loading will force the vane to interfere with casings and will damage the actuator. This event commonly occurs when proper clearance is not provided for the coupling to float between the actuator shaft and the driven device. When bolting the assembly together, if it is necessary to force the two components together with the coupling fitted between the shafts, chances are you have an end-loading problem.

The assembly position of the actuator must be in accordance with the actuator design, plant requirements and the valve model.

In order to assemble the actuator onto the valve, proceed as follows:

- Verify the coupling dimensions of the valve flange and stem; they must meet the actuator coupling dimensions
- The actuator shaft end machined for NAMUR adaptation has a flat side indicating the position of the vane. Actuators are shipped with the vane in the mid-position of the stroke. Move the vane to position end-stop that corresponds with the rotation desired to rotate the driven device
- Clean the valve and actuator coupling flanges, removing anything that might prevent electrical connection and adherence to the actuator flange interface: grease and paint residuals must be completely removed from threaded holes, if present
- Apply anti-seize grease to the valve stem to facilitate assembly
- Lift the actuator according instructions reported in Section 7.2
- If possible, place the valve stem in a vertical position to facilitate assembling - in this case the actuator must be lifted while the coupling flange is kept in the horizontal position
- If the assembly is done using an adapter and a coupling joint, assemble the coupling joint onto the valve stem before proceeding with the assembly of the actuator
- Lower the actuator onto the valve so that the valve stem (or the coupling joint) slips in the actuator without exerting any force and only with the weight of the actuator
- Installation must be performed by qualified personnel

⚠️ Hands must be kept away from the valve-actuator coupling area.

10. Installation on valve and earthing

- Clean and degrease the coupling bolts, stud bolts, nuts and the threads on actuator coupling flange.
- Fix the actuator to the valve by means of threaded connections (bolts, stud bolts and nuts)
- Tighten the bolts or nuts to the recommended tightening torque of the connecting stud bolts, in accordance with the size and material characteristics of the bolts installed by the customer. *See Table 1: Recommended Tightening Torque*

⚠ Attention: The actuator must be supported until it is fully coupled with the valve stem and until the fixing bolts are correctly tightened.

After the actuator has been assembled on the valve, check for possible damage to the paintwork and repair if necessary, according to the Rotork paint specification. Ensure that the coupling will slightly float up and down on the actuator and driven shafts. This check will guarantee concentricity between the actuator shaft and driven device.

⚠ Attention: Do not pressurise the actuator/valve adapter.

Table 1: Recommended tightening torque

Actuator Size	Bolt Size		Torque	
	Imperial*	Metric**	Imperial	Metric
KT-03	10-24/8-32	M5/M4	5.9/3.75 lbf.ft	8/5 Nm
KT-06	1/4-20/10-24	M6/M5	14/5.9 lbf.ft	16/8 Nm
KT-10	5/16-18	M8	15.6 lbf.ft	24 Nm
KT-20	3/8-16	M10	28 lbf.ft	48 Nm
KT-30	1/2-13	M12	68 lbf.ft	84 Nm
KT-40	5/8-11	M16	135 lbf.ft	207 Nm
KT-50	7/8-9	M22	386 lbf.ft	523 Nm
KT-60	1 1/8-7	M30	500 lbf.ft	678 Nm
KT-70	1 1/8-7	M30	500 lbf.ft	678 Nm

* Grade 5

** Class 10.9

⚠ Attention: End user should verify the electrical correctness of coupling, performing a standard continuity test between actuator and valve.

11. Actuator removal from the valve

The end-user is in charge of removing the actuator from the valve.

⚠ The actuator is to be removed exclusively by competent and qualified staff, wearing/using appropriate personal protection devices.

Ensure sufficient free space is available for the disassembly of the actuator from the valve.

⚠ Do not remove the actuator from the valve in the event the valve is blocked in the intermediate position (the valve stem must be in such a position so as not to rotate during the disassembly of the actuator). Contact Rotork.

In order to disassemble the actuator from the valve, proceed as follows:

- Cut off the pneumatic and electrical power supply (if present)
- Remove the pneumatic supply pipe from the actuator and vent any storage tanks (if present)
- Remove control and signal lines from electric components (if present)
- Sling the actuator following the instructions in Section 7
- Unscrew the bolts or the nuts from the stud bolts fixing the actuator to the valve
- Lift and remove the actuator from the valve

12. Operation

12.1 Actuator description

The KT-XX-DA series actuators are pneumatic, double-acting actuators specifically designed to provide efficiency and reliability in heavy duty services.

The KT-XX-SR series actuators are pneumatic, single-acting spring-return actuators. These actuators can be assembled in a 'spring to open' or in a 'spring to close' configuration. The spring may be removed from the housing and flipped to reverse fail direction for flexibility and reducing stock requirements.

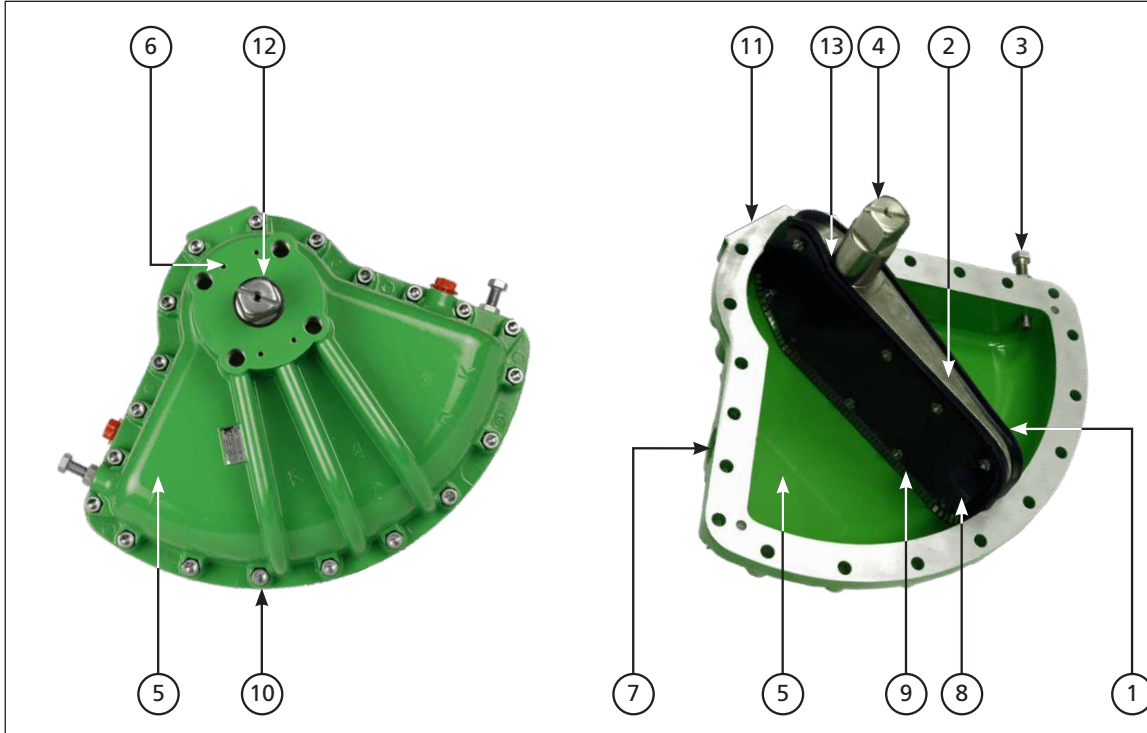

1 Dual Opposed Lip Seals

Air-assisted seal.

2 Integral Vane / Shaft Casting

Cast as a single piece, alloy steel ENP finish.

3 Bi-Directional Travel Stops

80° to 100° standard adjustments, stainless steel, extended travel stops available.

4 NAMUR Standard Shaft Detail

High-tensile output shafts for strength and durability, ENP finish for corrosion-resistance.

5 Powder-Coat Finish

TGIC-Polyester Epoxy powder-coat finish, inside and out.

6 Integral NAMUR Accessory Mount

Meets VDI/DE 3485 accessory mount standards for positioners, limit switches and indicators.

7 Large Air Inlet Port

NPT standard for Imperial, G/BSP standard for metric units.

8 Side-Plate Seal Retainer

Powder-coated steel.

9 Valve Seal Expanders

Ensures consistent lip seal-to-case contact.

10 Bolting Hardware

304 stainless steel.

11 Integral NAMUR Manifold

For direct-mount solenoid valve.

12 Vane Position Indicator

Flat surface parallel to vane position.

13 Shaft Seal

Flat surface parallel to vane position.

12. Operation

Actuator design characteristics are shown on the nameplate attached to the actuator. These actuators can be fitted with an emergency manual override suitable to operate the actuator in the event of fluid supply failure. This device can be of mechanical gear type operated by means of a handwheel.

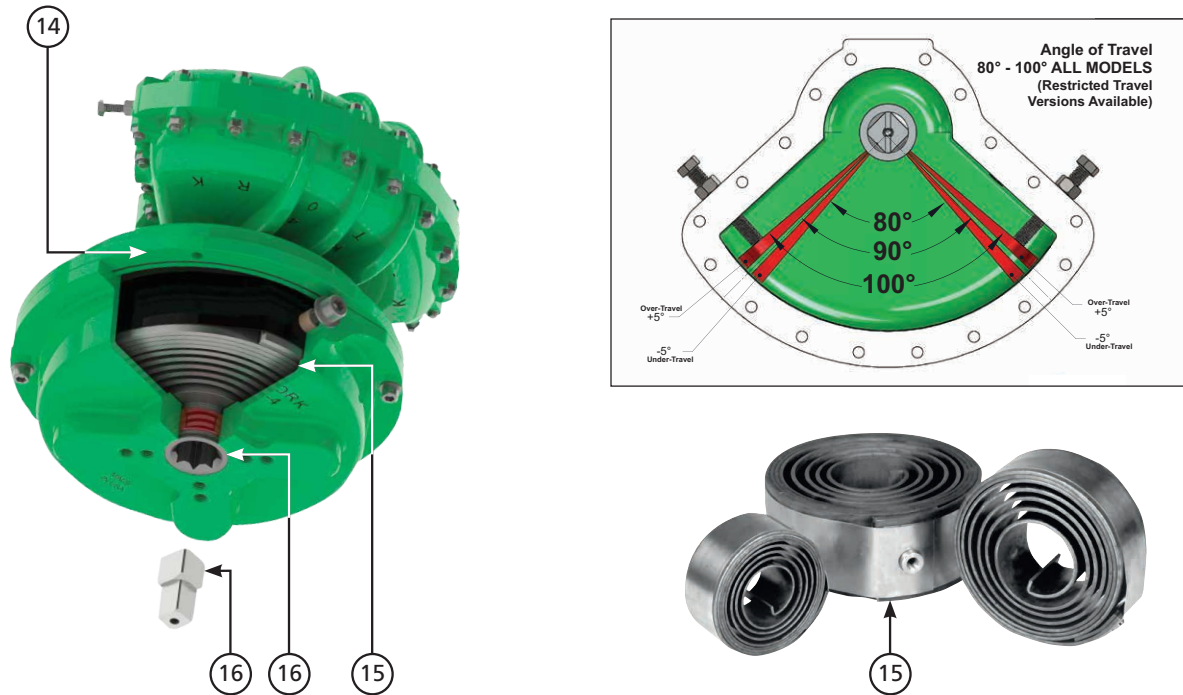

14 Spring housing

Protects externally from environmental corrosion and internally from supply air and atmospheric air.

15 Spring

Spring may be removed from housing and flipped to reverse fail direction for flexibility, reducing stock requirements. Spring includes steel safety band (patent-pending) around spring perimeter, allowing safe removal from housing.

16 Dual Output Drive

Spring-return unit standard with ISO 5211 'star pattern' female drive and ISO mount flange coupled with matching actuator drive shaft. Optional male drive insert to match actuator drive shaft.

Upon request, K-TORK series actuators can be equipped with additional accessories (limit switches box, positioner, position transmitter, control panel, etc.)

Use only control devices supplied by Rotork.

⚠ Installation must be performed according to IEC 60079-14 and the end user must follow special conditions for safe use detailed in document PUB010-046.

Figure 6: Actuator principal parts

12. Operation

The following instructions must be followed and integrated into end user safety program when installing and using Rotork products. Read and save all instructions prior to installing, operating and servicing this product.

Follow all warnings, cautions and instructions marked on and supplied with the product.

Install equipment as specified in Rotork installation instructions and as per applicable local and national codes of practice. Connect all products to the proper pipeline gas sources.

When replacement parts are required, ensure that the qualified service technician uses only replacement parts specified by Rotork.

Substitutions will invalidate any hazardous area certification and may result in fire, electrical shock, other hazards or improper operation.

12.2 Setting the actuator angular stroke

Warning: Certain valves incorporate their own stops. For such valves it is recommended that the actuator stop bolt positions coincide with the valve stop position.

12.2.1 Double-acting actuator

Setting of the 'closed valve' position (see Figure 7)

Adjust the stop bolt as follows:

- Pressurise the actuator from the first side until the actuator reaches the fully closed position
- Check where the actuator angular stroke stops. It should stop right at the fully closed position of the valve
- To change the stop position:
 - Simply loosen the lock nut **(2)**
 - Pressurise the actuator from the opposite side (moving the valve towards the opening position) so that the vane moves away from the stop bolt **(1)**
 - If the actuator did not reach the fully closed position, adjust the stop bolt **(1)** anti-clockwise
 - If the actuator stopped beyond the fully closed position, adjust the stop bolt **(1)** clockwise
 - Verify the newly obtained angular position with one closing stroke
 - Repeat this operation until the desired angle is obtained
- Hold the stop bolt **(1)** with a wrench and tighten the lock nut **(2)**. Ensure the washer **(3)** and the under seal is properly placed

Setting of the 'open valve' position (see Figure 7)

Adjust the stop bolt as follows:

- Pressurise the actuator from the second side until the actuator reaches the fully opened position
- Check where the actuator angular stroke stops. It should stop right at the fully opened position of the valve
- To change the stop position:
 - Simply loosen the lock nut **(2)**
 - Pressurise the actuator from the opposite side (moving the valve towards the closing position) so that the vane moves away from the stop bolt **(1)**
 - If the actuator did not reach the fully opened position, adjust the stop bolt **(1)** anti-clockwise
 - If the actuator stopped beyond the fully opened position, adjust the stop bolt **(1)** clockwise
 - Verify the newly obtained angular position with one opening stroke
 - Repeat this operation until the desired angle is obtained
- Hold the stop bolt **(1)** with a wrench and tighten the lock nut **(2)**. Ensure the washer **(3)** and the o-ring is properly placed

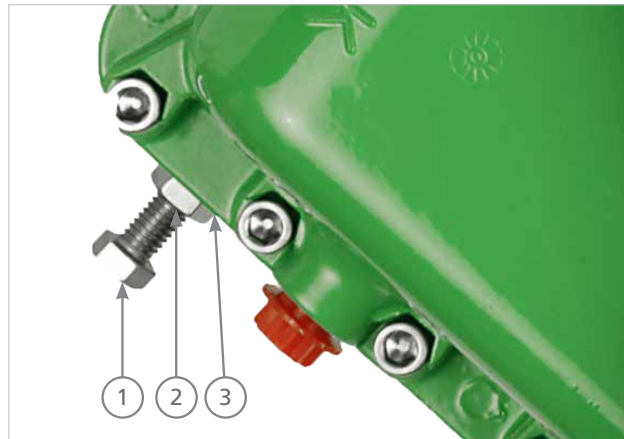

Figure 7: Setting angular stroke.

12. Operation

12.2.2 Fail to open actuator

Setting of the 'open valve' position (see Figure 7)

Adjust the stop bolt actuator, as follows:

- Check where the actuator angular stroke stops. It should stop right at the fully open position of the valve.
- To change the stop position:
 - Simply loosen the lock nut **(2)**
 - Pressurise the actuator until the stop bolt **(1)** turns freely, without any counter-pressure
 - If the actuator did not reach the fully opened position, adjust the stop bolt **(1)** anti-clockwise
 - If the actuator stopped beyond the fully opened position, adjust the stop bolt **(1)** clockwise
 - Verify the newly obtained angular position with one opening stroke
 - Repeat this operation until the desired angle is obtained
- Hold the stop bolt **(1)** with a wrench and tighten the lock nut **(2)**. Ensure the washer **(3)** and the under seal is properly placed

Setting of the 'close valve' position (see Figure 7)

Adjust the stop bolt actuator, as follows:

- Pressurise the actuator until the actuator reaches the fully closed position
- Check where the actuator angular stroke stops. It should stop right at the fully closed position of the valve
- To change the stop position:
 - Depressurise the actuator
 - Simply loosen the lock nut **(2)**

If the actuator did not reach the fully closed position, adjust the stop bolt **(1)** anti-clockwise

If the actuator stopped beyond the fully opened position, adjust the stop bolt **(1)** clockwise

Verify the newly obtained angular position with one closing stroke

Repeat this operation until the desired angle is obtained
- Hold the stop bol **(1)** with a wrench and tighten the lock nut **(2)**. Ensure the washer **(3)** and the under seal is properly placed

12.2.3 Fail to close actuator

(see Figure 7)

- Actuators also available to order as fail to close. Refer to Section 12.2.2 simply reversing the 'open' and 'close' instructions

12. Operation

12.3 Power supply

Prior to starting the actuator up, check the minimum/maximum supply pressure displayed on the name plate (see Section 5).

Ensure that the actuator should not be exposed to pressure exceeding to the maximum rating as indicated on the nameplate.

Verify that the medium composition (e.g. filtration, hydration) corresponds to that for which the actuator was manufactured.

⚠ Contact Rotork to check the compatibility of the actuator with the chemical composition of the supply medium.

⚠ Depending on the control circuit design, pneumatically powered actuators may exhaust the power supply gas into the atmosphere during normal operation. This may present an unacceptable hazard in some applications.

12.4 Pneumatic connections

- Before connecting the actuator to the pneumatic supply line, verify metric or imperial threads, verify sizes of pipes and fittings according to applicable plant specifications, in order to guarantee the air flow for a proper operation of the actuator
- Take every precaution to remove any solid or liquid pollutant from the pipe work, to avoid actuator damages to or reduced of performance. Clean the inside of the connection pipes by washing them with a suitable detergent and by blowing air into them
- The connecting pipes must be properly shaped and fixed so as to prevent stress or loosening of threaded connections

Important: For tapered – threaded fluid connections, apply a thin layer of thread sealing product (Loctite 577 or equivalent) to ensure a good seal.

⚠ Connect the pneumatic power source in accordance to the applicable operating diagram, please refer to specific project for details.

12.5 Electrical connections

⚠ Check electrical components supply voltage, before start-up.

The following instructions are applicable to actuators provided with electric accessories (such as micro switches, solenoid valves, etc.).

Check that the supply voltage is the same as stated for the actuator control components.

⚠ The user must guarantee equal voltage potential between the valve and the actuator and provide appropriate earthing. It is the responsibility of the final user to indicate and maintain the earthed connections on the actuator.

⚠ Access to live electrical conductors is forbidden in hazardous areas unless done under a special permit. Otherwise, all power should be isolated and the unit moved to a non-hazardous area for repair.

Electrical connection can be performed as follows:

- Check that no power is present
- Remove the covers of the electric components
- Remove the protection plastic plugs from the cable entries
- In case the unit is installed in a hazardous area, it is mandatory to use only appropriately certified reduction fittings, cable glands, fittings and explosion-proof cables
- Pay attention to the correct installation of the o-rings of the cable glands so as to prevent the infiltration of water and debris inside the electric components
- Ensure that the cable glands are tightened in the threaded inlets, so as to guarantee the waterproof and explosion proof protection
- The size of the electric supply cable must suit the electric power demand
- Insert the connection cables through cable glands and complete cable gland assembly according to the cable gland manufacturer's instructions
- Connect the cable wires to the terminal blocks in accordance with the applicable wiring diagram
- Electric connections are to be made by using rigid conduits and trailing cables so as to prevent mechanical stresses in the cable entries
- On the unused entries of the junction box, replace the plastic plugs with approved metal plugs, in order to guarantee a perfect seal and to comply with explosion safety protection codes

12. Operation

- Assemble the covers of the electric components, verifying that the seals and the edges of the covers are in good condition and clean. No wires nor other objects should be between the covers and the body of the electric components
- Once connections have been completed, check if controls and signals work properly

 **Actuator and electrical components must be protected from electrical sparks, lightning, magnetic or electro-magnetic fields, at user's care.**

 **Installation must be performed according to IEC 60079-14 and the end user must follow special conditions for safe use detailed in document PUB010-046.**

12.6 Start-up

During the start-up of the actuator, it is necessary to check that:

- the medium supply pressures, as well as its quality (filtering degree, dehydration) are as prescribed
- the feeding voltage values of electrical components (solenoid valves, micro switches, pressure switches etc., if applicable) are as prescribed
- the actuator controls such as remote control, local control, emergency control etc. (if applicable) work properly
- the required remote signals (such as valve position, etc.) are correct
- the components setting of the actuator control unit is according to the plant requirements
- there are no leakages in the pneumatic connections. If necessary, tighten the fittings
- the painted parts have not been damaged during transport, assembling or storage operations. If damage has occurred, remove rust and repair the damaged parts following the applicable painting specifications, please contact Rotork
- actuator and all of its control accessories work as expected
- the operating time is in accordance with requirements

12.7 Speed adjustment

Slower operation of the actuator is possible by restricting the air exhausting from the actuator. The most common device used for adjusting cycle speeds is a "flow control valve" that free flows air into the actuator in one direction and meters the air in the opposite direction. Flow control mufflers will accomplish the same results when utilised with a 5-ported direct acting solenoid valve that has independent exhaust ports.

13. Dismantling and disposal

K-TORK range actuators are designed and built to provide a long operative life.

At the end of their operative life, they will have to be removed from the valve and subsequently disposed of.

⚠️ Prior to dismantling the actuator, check if some of its parts are still under pressure. Verify that the pneumatic storage tank (if applicable) is depressurised, otherwise slowly open the drain valve.

⚠️ The spring cartridge module contains potential energy due to compressed elastic elements. After removing the spring cartridge as prescribed in Section 16.2.3, the spring cartridge have to be returned to the manufacturer's plant, upon agreement with Rotork.

♻️ Collect the grease and the oil during dismantling to avoid disposal of pollutants in the environment; the discarded material is to be disposed in accordance with the local environmental laws and regulations.

- Actuators are built in modules and this facilitates dismantling
- Dismount the actuator and separate the various sections and components according to the type of material
- Dispose of the pieces of steel, cast iron and aluminium alloys as metal scraps
- Dispose of the rubber, PVC, resins etc. separately, in accordance with the existing national and regional regulations
- Electrical components are to be separately disposed on specialised disposal sites
- Actuators manufactured after 1993 do not contain asbestos or its by-products

14. Rotork sales and service

If your Rotork actuator has been correctly installed and sealed, it will give years of trouble-free service. Should you require technical assistance or spares, Rotork guarantees one of the highest levels of service in the flow control industry. Contact your local Rotork representative or the factory directly at the address on the nameplate, quoting the actuator type and serial number.

Some actuators have a special spare parts list. Refer to the project-specific documentation for further details.

15. Troubleshooting

Table 2: Troubleshooting

Troubleshooting		
FAILURE	POSSIBLE CAUSES	CORRECTIVE MEASURES
Erratic movement	Irregular supply of operating medium.	Verify the supply pressure and correct as necessary.
	Worn parts.	Dismantle. Visually inspect for significant wear. Actuator replacement may be required.
	Fault in control accessories (if present).	Contact Rotork.
	Fault of pipeline valve.	Consult the valve manufacture's documentation.
Incorrect valve position	Incorrect setting of mechanical stops (actuator and/or valve).	Check the position of the mechanical stop bolts and readjust. (see Section 12.2).
	Incorrect signal from limit switches (if present).	Check limit switch position.
	Fault of pipeline valve.	Consult the valve manufacture's documentation.
Insufficient valve rotation	Insufficient air supply to produce the stroke.	Increase air supply flow.
	Incorrect setting of mechanical stops.	Adjust the stop bolts. (see Section 12.2).
	Debris left in the actuator during maintenance.	Disassemble the actuator to remove debris. Reassemble the actuator.
	Fault of pipeline valve.	Consult the valve manufacture's documentation.
Leakage from actuator vane	Worn seals.	Disassemble the actuator and replace the seals. Reassemble the actuator. (see Section 16.1).
Leakage from the setting bolt	Worn seals.	Remove the stop bolt from the actuator and replace the seals. Reassemble the stop bolt. (see Section 16.1).
LOSS OF POWER	POSSIBLE CAUSES	CORRECTIVE MEASURES
	Inadequate supply pressure.	Ensure that the supply pressure is above the minimum operating pressure of the actuator and that the output torque produced at supply pressure exceeds the required valve torque.
	Incorrect speed control settings.	Adjust the speed controls to increase flow.
	Pipe work blocked, crushed or leaking.	Examine the pipe work for blockages, crushed pipes or leakages. Clear or replace as necessary.
	Fault of control accessories (If present).	Contact Rotork.
	High valve torque or incorrect sizing.	Consult the valve manufacturer's documentation.

For other problems, please contact Rotork.

16. Periodic maintenance

16.1 Periodic inspections

K-TORK range actuators are designed to work for long periods of time under severe conditions. A preventive approach to maintenance helps to avoid costly down time and can reduce the cost of ownership.

Rotork can provide actuator maintenance contracts tailored to meet each individual customer's requirement.

Perform checks specified in the following periodic maintenance schedule, in accordance with the plant maintenance procedures, and in compliance with the local rules and regulations.

Table 3: Periodic maintenance schedule

Periodic Maintenance Schedule			
Maintenance work	Month	Year	Work
Visually check the external components of the actuator as well as the control accessories (if applicable) for physical damage and repair or replace as required. Verify the integrity of welding if applicable. In case an anomaly is detected, please contact Rotork.	6	-	-
Ensure no leaks are present on the actuator parts under pressure. Check pneumatic connections for leaks. Tighten plugs and pipe fittings as required.	-	1	-
Ensure no leaks are present on the control panel (if present).	-	1	-
Remove built-up dust and dirt from all actuator surfaces.	-	1	-
Inspect actuator paint work for damage to ensure continued corrosion protection. Touch-up as required in accordance with the applicable paint specifications, please contact Rotork.	-	1	-
Verify operation. The actuator should be cycled several times with the local and remote (if present) control.	1	N/A	N/A
Ensure that the actuator operates the valve correctly within the required cycle time.	-	1	-
Check up and clean the air filter element (if present).	6	-	-
Check the state of electric components (if present) Remove the covers from the electric components, check the state of electric device, the tightness of terminal blocks, the presence of oxidation and humidity. Check the cable gland seals.	-	1	-
Check the threaded connections (bolts, studs and nuts) connecting the actuator to the valve. If necessary tighten the bolts or the nuts of the connecting studs to the correct torque, in accordance with the size and the characteristics of the fastener material installed by the customer.	-	1	-
Replace actuator seals.	-	5	See Section 16.2

16. Periodic maintenance

16.2 Pneumatic actuator seals replacement

Original spare parts and accessories can be ordered from your local Rotork office.

When ordering spare parts, it is necessary to provide the following:

1. The actuator model and serial number from nameplate (see Section 5).
2. The spare part item number, quantity and description (see Table 5).

Some actuators have a special spare parts list. Refer to the project specific documentation for further details.

16.2.1 Preparation

- a) Remove the actuator from the valve (see Section 11).
- b) The actuator modules are to be disassembled in a clean area, free of dust.
- c) Place the actuator in a stable position, e.g. on a workbench.
- d) If the actuator is provided with a control panel, remove the panel and any other component fitted to the pneumatic actuator (refer to the project specific documentation for the details).
- e) Remove the limit switch box (if present) and its mounting bracket.

16.2.2 Removing the spring module

Equipment required to remove the spring module from the actuator:

1. Adjustable air regulator.
2. Air tubing and fittings connect the regulator to the actuator air port.
3. Spring shaft retainer.
4. Bolts for the spring retainer.

Spring principal parts (see Figure 8):

- (1) Spring housing
- (2) Spring cover
- (3) Spring retainer
- (4) Spring anchor bolt
- (5) Power spring
- (6) Socket head screw

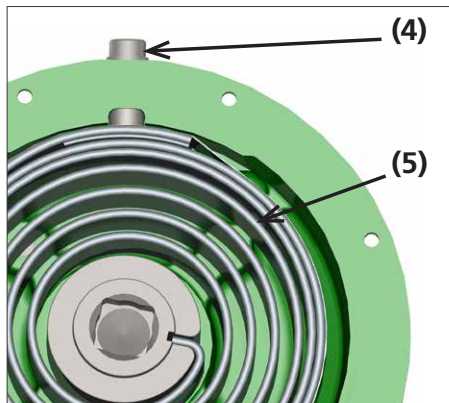
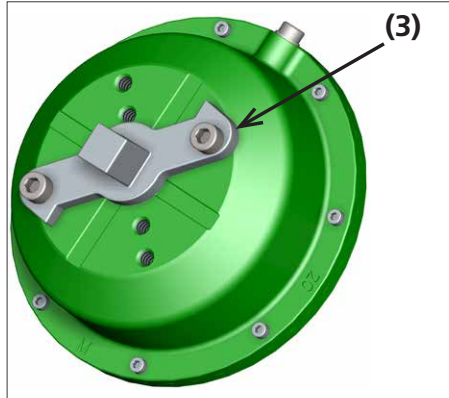
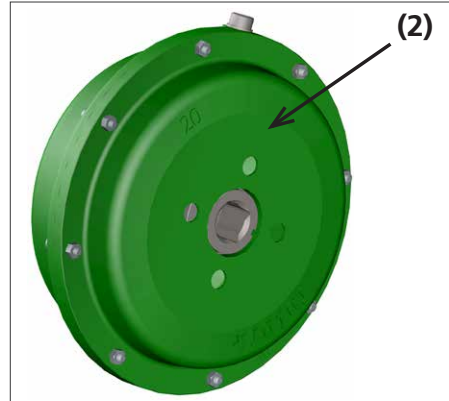
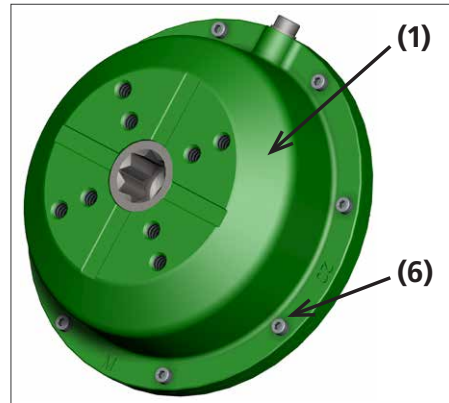

Figure 8: Spring principal parts.

16. Periodic maintenance

Properly retain the spring

As assembled, the spring force is acting against the spring housing and the actuator shaft. The force on the actuator shaft must be retained to the spring housing before removing the spring assembly from the actuator.

- Plumb the air regulator to the unvented side of the actuator.
- Set the regulator to 0 bar and apply pressurised air to the regulator.
- Slowly increase the air pressure until you see the actuator shaft rotate.
- Increase the air pressure until the actuator vane is in mid position (45° of rotation). Watch the vane indicator mark to know when the actuator is in mid position.
- Install the spring retainer. The bolt holes in the spring retainer should align with the threaded holes in the spring housing. If not, use the regulator to adjust the air pressure so that the spring shaft will rotate until the holes are aligned. Install the spring retainer bolts.
- Once the spring retainer is installed slowly reduce the air pressure until the regulator is at 0 bar.
- The spring is now retained.

Spring removal

To remove the spring assembly from the actuator, the spring housing must be separated from the spring cover.

⚠ The spring is preloaded and stores a large amount of energy. The spring must be properly retained before removal to avoid injury and damage. Read through the instructions and be sure you fully understand them before attempting to disassemble the spring from the actuator. Before proceeding, check that the spring retainer is properly installed with the vane in the mid position.

⚠ Do not remove the spring anchor bolt. Doing this will damage the spring and could possibly cause injury.

Refer to Figure 8:

- Remove and retain the perimeter socket head cap screws (6), with the relevant washers and nuts, holding the spring housing (1) and spring cover (2) together.
- You should now be able to remove the spring by separating the spring housing and the spring cover by pulling the spring housing away from the actuator. The power spring and the spring shaft should remain in the spring cover as it is removed. The spring shaft engages with the actuator shaft, the spring shaft should slide easily off the off the actuator shaft.
- Clean both spring assembly halves removing silicone rubber sealant with mineral spirit or a suitable solvent.
- The spring cover is attached to the actuator by 4 bolts and will remain on the actuator.

NOTE: If the spring cover will be removed from the actuator, remove and retain the four screws; clean both the interface surfaces removing silicone rubber sealant with mineral spirit or a suitable solvent.

16.2.3 Dismantling actuator

See exploded drawing/parts list (Figure 10).

⚠ Before dismantling, check there are no burrs on square drive shafts. If there are, remove to avoid damage to bearings and shaft seals during removal of case halves.

- Remove all casing bolts and nuts.
- Separate the two case halves with a K-TORK tool model CP 1-4 or CP 5-6 (not included, consult Rotork).
- Clean both case halves removing silicone rubber sealant with mineral spirit or a suitable solvent.
- Replace and lubricate shaft seals in case housings.
- Remove nuts and seal side plates, expanders and seals from vane.
- Clean vane.

16.2.4 Reassemble vane

- Check studs are tight through vane and equal length on each side. If not, apply Loctite to thread and relocate correctly in vane.
- Apply silicone sealant around bottom of studs to prevent air leakage through seal on vane stud holes. Use either GT-3100 One Part RTV Silicone or Dow Corning Silicone # 732.
- Fit new seal over studs after checking profile matches vane profile.
- Fit seal expander teeth pointing away from vane.
- Fit side plate over studs.
- Center expanders and side plate so there will be an equal amount of seal around the expanders. The expanders must not touch the actuator case half's.
- Fit new nylon insert lock nuts to studs. Tighten nuts to torque values in Table 4.

Table 4: Recommended tightening torque

Model No.	Torque	
	Imperial (lbf.in)	Metric (Nm)
KT-03	1 to 2	0.14 to 0.28
KT-06	2.5 to 5	0.28 to 0.56
KT-10	8	1
KT-20	20	2.3
KT-30	30	3.4
KT-40	30	3.4
KT-50	65	7.3
KT-60	100	11.3
KT-70	100	11.3

16. Periodic maintenance

16.2.5 Reassemble actuator

- Coat bearings and internal vane seal areas of the case halves with grease supplied with the seal kits.
- Clean case flanges with isopropyl alcohol. Insure that all grease is removed from the flanges.
- Lightly and evenly coat joint face of one case half with silicone sealant using GT-3100 One Part RTV Silicone or Dow Corning Silicone # 732.

⚠ Excess sealant, if extruded inside case, will damage seals.

- Remove all excess sealant especially from inside edge.
- Insert vane into one case half, turning it to ease square on vane shaft through shaft seal. Watch that the vane slides smoothly through the shaft seals. Lightly rotating the vane assembly may be necessary.
- Fit remaining case half on top of the other turning it to ease vane shaft square through shaft seal.

⚠ Check that vane lip seals are not trapped at case joint flange face when seals are fitted.

- Tighten case screws to the following torques:

Table 5: Recommended tightening torque

Model No.	Torque	
	Imperial (lbf.in)	Metric (Nm)
KT-03	18	2
KT-06	35	4
KT-10	98	11
KT-20	180	20
KT-30	180	20
KT-40	250	28
KT-50	792	89
KT-60	1540	174
KT-70	1540	174

- Following assembly, rotate vane manually to check movement and wipe away sealant extruded internally.
- Allow setting time for sealant before applying test air pressure. See instructions on sealant for cure times recommended.

16.2.6 Mechanical travel stop removal

With the actuator placed in a stable position, e.g. on a workbench.

See Figure 9 and proceed as follows:

- Loosen the lock nut **(2)**.
- Completely loose the stop bolt **(1)**.
- Remove and retain the stop bolt **(1)** and the lock nut **(2)**. If necessary replace them.
- Remove and replace the washer **(3)** and the under o-ring seal. Clean the o-ring seat.

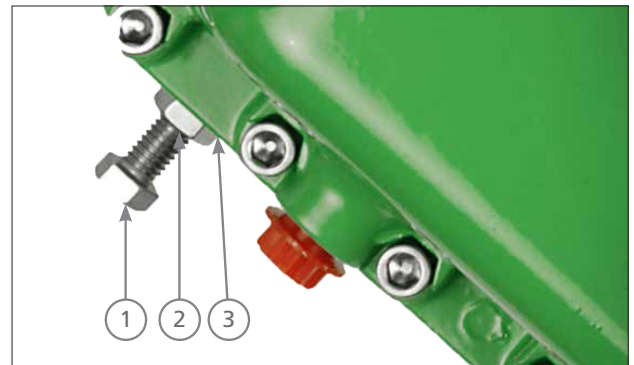

Figure 9: Stop bolt sealing replacement.

After the final reassembly on the valve, execute the stop bolt setting as in Section 12.2.

16. Periodic maintenance

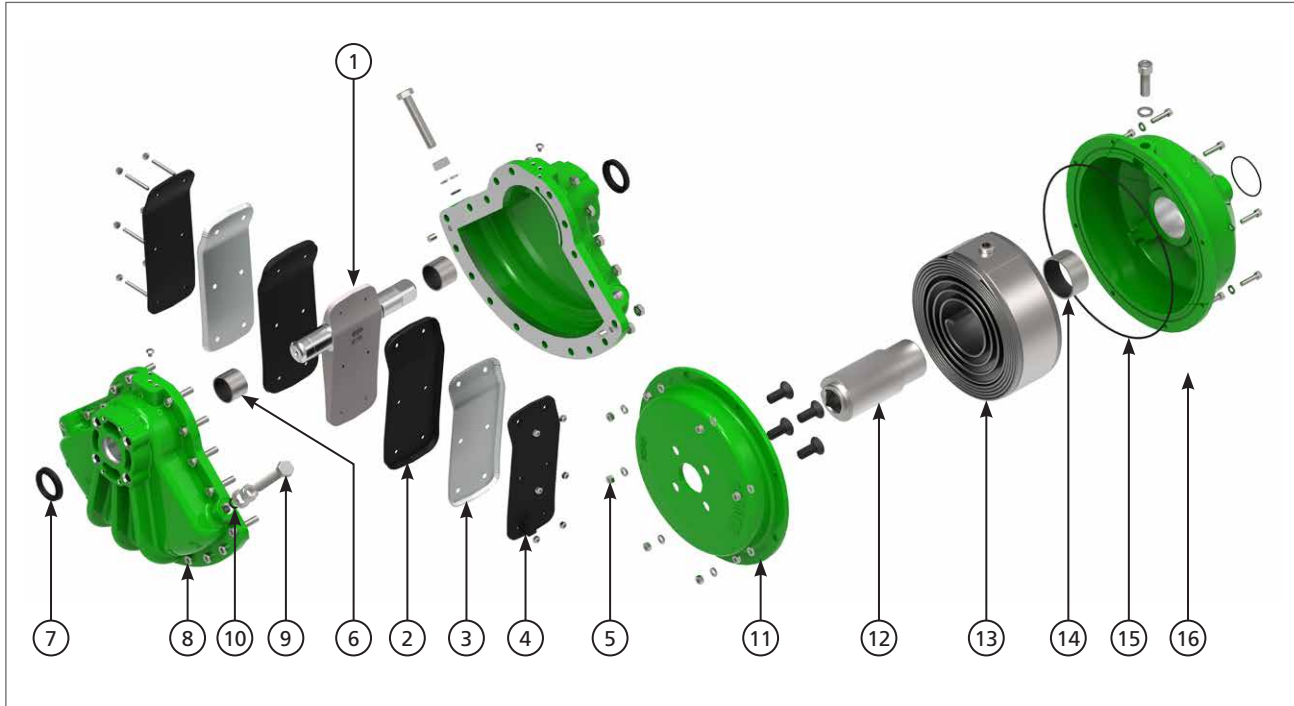

Figure 10: Exploded view of K-TORK range actuator and spring assembly.

Materials of construction for double-acting and spring-return actuators

Item	QTY	Description	Material
1	1	Integral Vane / Shaft	ASTM A217 or 915 Cast Steel - Electroless Nickel Plated
2	2	Vane Seal	HNBR
3	2	Vane Seal Expander	304 Stainless Spring Steel
4	2	Vane Seal Side Plate Retainer	Carbon Steel - Epoxy Finish
5	-	Assembly Hardware	304 Stainless Steel
6	2	Shaft Bushing	Bronze Bushing - PTFE Lined, Steel Backed
7	2	Shaft Seal	HNBR
8	2	Outer Case	LM20 or LM25 Aluminium Alloy (A413 or A356A)
9	2	Stop Bolt	304 Stainless Steel
10	2	Stop Bolt O-Ring	Viton Rubber
11	1	Spring Housing Cover	A356A Aluminium Alloy
12	1	Spring Shaft	Steel - Electroless Nickel Plated
13	1 ¹	Spring	Carbon Steel
14	1	Shaft Bushing	Bronze Bushing - PTFE Lined, Steel Backed
15	1	Spring Housing O-Ring Seal	Viton Rubber
16	1	Spring Housing	A356A Aluminium Alloy
Note	-	Interior / Exterior Finish	Polyester Epoxy Powder Coating (Optional RANGER CG Coating Available)

1 – The KT-40 has two springs.

16. Periodic maintenance

16.2.7 Installing the spring module to the actuator

The spring module with the keeper plate should be provided in the mid-stroke position. Before proceeding, check that the keeper plate is properly installed and the actuator is in mid-stroke position.

Place the actuator in a stable position, e.g. on a workbench. See Figure 8 and proceed as follows:

- a) Once the spring cover has been removed from the spring module, apply a thin film of recommended silicone sealant to the mounting face on the output side of the actuator. Attach the spring cover to the actuator using the four flat head screws provided.
- b) Position the O-ring in the groove on the spring housing or spring cover (this groove's location will depend on spring assembly size).
- c) Align the actuator shaft to the spring shaft, ensuring the vane is in the mid-position (45° of rotation). The mount bolt holes of the spring housing should match the orientation of the actuator mount bolt holes.
- d) Install the spring module.
- e) Carefully rotate the actuator vane to align the flange bolt holes on the spring housing with the corresponding flange bolt holes in the spring cover. Install the socket head cap screws, including washers and nuts, and tighten. **ALL FLANGE BOLTS MUST BE INSTALLED AND PROPERLY TIGHTENED BEFORE REMOVING THE KEEPER PLATE.**

Removing the Keeper Plate

- f) Connect air supply using a regulator to actuator inlet port (port opposing spring action).
- g) Increase air pressure slowly until actuator shaft is balanced in the keeper plate. Typically 38 to 42 psi to balance actuator shaft for springs wound for 80 psi service.
- h) Loosen the keeper plate bolts. With proper air pressure, the bolts will not bind. If binding adjust air until bolts are loose enough to be removed.
- i) Remove the spring retainer keeper plate.
- j) Slowly reduce air supply with regulator to 0 psi.

After the final reassembly on the valve, execute the stop bolt setting as in Section 12.2.

11.1.2.8 Final reassembly and testing

- a) Assemble the components on the actuator (e.g. limit switch box, position transmitter), if any.
- b) Assemble the control panel, if any.
- c) The actuator must be tested prior to being mounted on a valve.
 - Place the actuator in a stable position, e.g. on a workbench.
 - Connect the pneumatic supply to the actuator and cycle the actuator several times in order to verify that it operates smoothly. Ensure there are no leaks from pneumatic connections or housing seals.
 - If painted parts have been damaged during disassembly and/or reassembly, repaint in accordance with the applicable paint specification, available upon request from Rotork.

The actuator may now be mounted to a valve.

Recommended spare parts

Table 5: Double-acting spare parts list (seal kit part numbers)

Model No.	Spare Part No.	
	Standard Temp.	High Temp.
KT-03*	2511800	2511801
KT-06*	2511000	2511001
KT-10	2011010	2011011
KT-20	2011020	2011021
KT-30	2011030	2011031
KT-40	2011040	2011041
KT-50	2011050	2011051
KT-60	2011060	2011061
KT-70	2011070	2011071

- Seal kit contains:
 - 2 vanes seals (item 2)
 - 2 expanders (item 3)
 - 2 shaft seals (item 11)
 - 2 stop bolts seals (item 14)
 - Packet of grease
 - Nylon insert lock nuts (item 6)

In addition a tube of sealant, either GT-3100 One Part RTV Silicone or Dow Corning Silicone # 732 will be required to seal the case halves.

* KT-03 and KT-06 not available, number is for FULL actuator replacements

rotork®



www.rotork.com

A full listing of our worldwide sales and service network is available on our website.

Rotork plc
Brassmill Lane,
Bath, UK

tel +44 (0)1225 733200
email mail@rotork.com

USA
Rotork Controls Inc.
675 Mile Crossing Blvd., Rochester NY, USA

tel +1 585 247 2304
email sales@rotork.com

PUB097-008-00
Issue 09/24

As part of a process of on-going product development, Rotork reserves the right to amend and change specifications without prior notice. Published data may be subject to change. For the very latest version release, visit our website at www.rotork.com

The name Rotork is a registered trademark. Rotork recognises all registered trademarks. Published and produced in the UK by Rotork. POLTG1024