

The Modbus card described in this manual has been designed to fully comply with Modbus protocol specifications. This means that network biasing must be used somewhere on the highway to ensure good communications. See Section 4.

The Modbus card described in this manual contains static-sensitive devices. Suitable precautions, such as wearing an earthed anti-static wrist strap, should be taken before handling the card. It should be kept in an anti-static bag or box while it is not fitted within an actuator.

- Note 1:** The Modbus modules described in this manual are suitable for inclusion in Rotork IQ3, SI3, SI4, CK, CVA (Only firmware version CVA1.14 or later), CMA, K-range actuators and ELB unit.
- Note 2:** Although the same Modbus module is fitted to the different ranges of actuators, there will be different numbers of valid inputs and outputs for each range, depending on the actuator capabilities. For example, actuators not fitted with a battery cannot report Battery Low.
- Note 3:** The information in this manual relates to the following Modbus module firmware version: V0050 or later.
- Note 4:** Throughout this manual the Modbus module may simply be referred to as the module, card or MFU (Modbus Field Unit – the circuit board fitted to the actuator in the field).
- Note 5:** Inputs are the status messages from the actuator and outputs are the command messages to the actuator.

Contents

Glossary of terms	5
Abbreviations	6
1. Introduction	7
1.1 General	7
2. Modbus option card properties	8
2.1 Mechanical properties	8
2.2 Electrical properties	9
2.3 Operation and storage	9
3. Fitting the Modbus module option card	10
3.1 Inside an IQ3 actuator	10
3.2 Replacing or fitting a Modbus module option card	11
3.3 Inside an SI3 or SI4 actuator	12
3.4 Inside a CVA actuator	13
3.5 Inside a CMA actuator	14
3.5.1 CMA menu structure	15
3.5.2 CMA advanced menu access	16
3.6 Inside the Electronic Line Break unit	18
3.6.1 Scope of Modbus option in ELB	18
3.7 Inside a K-Range actuator	19
4. RS-485 data highway, connections and MFU setup	20
4.1 Data highway	20
4.2 Highway topology	21
4.3 Cable types	22
4.4 Termination network	23
4.5 Inter-connecting the highway and setting up the MFU	24
4.5.1 Single highway	24
4.5.2 Dual highway	24
4.5.3 Single highway with internal repeater	25
5. The actuator input and output signals	26
5.1 Control outputs	26
5.1.1 Controls priority	29
5.1.2 Modbus control using individual coil commands	29
5.1.3 Modbus control using the ACTCON register	30
5.1.4 Modbus control using the Actuator Position DV register	30
5.1.5 The IQ3 'S' contacts (Modbus DOs)	30
5.1.6 IQ3 Modbus network control disable feature	30
5.2 Actuator digital input status feedback	31
5.2.1 Digital Inputs from the actuator	31
5.3 Actuator analogue input feedback	34
5.4 IQ3 data logger information	34
6. Modbus communication	35
6.1 Electrical specification	35
6.2 Outer protocol	35
6.3 Repeaters	35
6.4 Dual channel mode	36

7. Modbus database	37
7.1 Modbus RTU message frame	37
7.2 Modbus address	37
7.3 Function code support.....	38
7.4 Broadcast commands.....	39
7.5 Data location offsets.....	39
7.6 Data locations.....	40
7.6.1 Data accessed with function code 01 – Read Coils	40
7.6.2 Data accessed with function code 02 – Read Discrete Inputs	41
7.6.3 Data accessed with function code 03 – Read Holding Registers	42
7.6.4 Data accessed with function code 04 – Read Input Registers	45
7.6.5 Data accessed with function code 05 and 15 – Force Single and Multiple Coils	46
7.6.6 Data accessed with function code 06 and 16 – Preset Single and Multiple Registers.....	47
7.6.7 Data accessed with function code 07 – Read Exception Status	47
7.6.8 Data accessed with function code 08 – Loopback Diagnostic Test	47
7.6.9 Data accessed with function code 17 – Report Slave ID.....	48
7.6.10 ELB only – Alarm table.....	48
7.6.11 ELB only – Alerts table.....	49
7.7 Database summary	50
7.8 Configuration registers	52
7.9 Actuator related configurable parameter registers.....	54
7.9.1 Action on Loss of Comms (Register 7)	54
7.9.2 Limited range position minimum and maximum (Registers 8 and 9).....	54
7.9.3 Deadband and hysteresis (Registers 10 and 14)	55
7.9.4 Motion Inhibit Timer (MIT) (Register 11).....	55
7.9.5 Auxiliary Input Mask (Register 12).....	56
7.9.6 Comms Lost Position (Register 13)	57
7.9.7 ESD DI-4/Net Disable (Register 19)	57
7.9.8 Analogue Input Max/Min (Register 20).....	57
7.9.9 Comms Fault Timer (Register 21).....	57
7.10 Modbus network related configurable parameter registers.....	58
7.10.1 Modbus Address (Register 22)	58
7.10.2 Baud Rate (Register 23).....	58
7.10.3 Parity and Stop Bits (Register 24)	58
7.10.4 Termination (Register 25)	58
7.10.5 Actuator Tag Name (Register 26 to 31).....	58
8. Setting up and maintaining the MFU	59
8.1 Using a network configuration tool	59
8.2 Setting up an IQ3 with the setting tool	59
8.3 Maintenance and repair	59
8.4 Records.....	60
8.4.1 Troubleshooting.....	61

Glossary of terms

Address	The unique address for a node on a particular highway of the fieldbus. The address range is 1-247.
Enlight	A graphical user interface for Bluetooth communication with CVA actuators. This is downloadable from the Rotork web site, www.rotork.com .
Fieldbus	The digital, two-way, multi-drop communication links.
Field Unit	The Modbus Mk 3 option card fitted to the actuator.
Insight2	A graphical user interface for communication with IQ3 and CVA actuators. This is downloadable from the Rotork web site, www.rotork.com .
Interoperability	The capability for a device from one manufacturer to interact with that of another manufacturer, on a fieldbus network, without loss of functionality.
Master/Slave	Method of communication used by the Modbus Module. The fieldbus requires a Modbus master to control the data exchange on the highway.
Modbus	The communication protocol used for data exchange, as defined in IEC 61850.
Modbus RTU	The version of the protocol used by the Rotork module.
Node	A single device on the fieldbus.
Parity	Bit added to data for error detection.
Partial Stroke Test	Moving a little-used valve by a small percentage from an end limit and then returning it, proving that it will operate when required. Safety-related.
RS-485	The electrical properties of the data highway as defined by the IEC 8482 standard, copper conductors, 2-wire twisted pair.
Segment	A section of an RS-485 fieldbus that is terminated at each end in its characteristic impedance. Each Segment can include up to 32 devices with unitary load.

Abbreviations

ACTCON	Actuator Control (Register)
CMA	Compact Modulating Actuator
Comms	Communications
CP	Common Protocol
CRC	Cyclic Redundancy Check (error detection)
CVA	Control Valve Actuator
CVL	Linear version of CVA
CVQ	Quarter-turn version of CVA
DIO 1	Digital Input/Output Board, type 1
DIO 2	Digital Input/Output Board, type 2
DV	Desired Value
ELB	Electronic Line Break
ESD	Emergency Shut Down
HD	High differential pressure
HDC	High differential pressure while closing
IEC	International Electrotechnical Commission
MFU	Modbus Field Unit
MV	Measured Value
PCB	Printed Circuit Board
PLC	Programmable Logic Controller
RAM	Random Access Memory
RIRO 1	Remote Input/Remote Output Board, Type 1
RIRO 2	Remote Input/Remote Output Board, Type 2
R/O	Read Only
ROD	Rate of Drop
ROM	Read Only Memory
R/W	Read/Write
RTU	Remote Terminal Unit
SW	Software
UPS	Uninterruptible Power Supply (CVA only)

1. Introduction

The Rotork Modbus Module Actuator Field Control option card (MFU) uses 2-wire (half duplex) RS-485 and the Modbus RTU protocol to allow for information exchange and control over the data highway between the actuator and a suitable host system with a Modbus capability.

The module is an integral part of the actuator in which it is housed and is fitted within the main electrical housing. For the IQ3 (encompassing all IQ3 and IQ3 Pro variants), CVA and K-Range products, this electrical housing is double-sealed and need not be opened once the actuator leaves the assembly plant. The CMA range of actuators does not have double sealing and the electrical cover is required to be opened for connecting to field connections.

All adjustments to the settings for the module may be made via the Modbus data highway using a Modbus master tool or via the Infra-red or Bluetooth actuator setting tools for those products that support those interfaces.

The settings which must be correct for communication are: address, baud rate, parity and stop bits. These are described in Section 6. The default values are: address 247, baud rate 9600, parity None and stop bits 1.

The Modbus module circuits do not impinge on the actuator control electronics; the actuator itself remaining fully self-protecting. The module performs the tasks of network interface, actuator data collection and the issuing of actuator commands.

The Modbus module may command the actuator into which it is fitted to: open, stop, close, perform an ESD operation, perform a partial stroke test (IQ3 only) or move to a set position. Commands to the module come from the network and will have been generated in a master controller. The module operates as a slave in Master/Slave communication mode only, using the Modbus RTU protocol.



Fig 1: The Modbus module option card device compatibility

1.1 General

The Modbus module has three variants:

- Single RS-485 highway
- Dual independent isolated RS-485 highways
- Single RS-485 highway with inbuilt isolating repeater

Communication medium: RS-485 2-wire highway (single or dual), half duplex

Protocol: Modbus RTU

Mode: Master/Slave; module is a slave.

2. Modbus option card properties

2.1 Mechanical properties

The Modbus module option card differs from all previous versions in that it interfaces directly between the Modbus RTU network and the communication protocol used within the actuator. There is no intermediate circuit board that it plugs into. We refer to it as the Modbus Field Unit, MFU.

The MFU is a single rectangular printed circuit board that fits inside the actuator electrical housing. It connects directly to the Control Module PCB of the actuator by a ten pin connector (10 way header, SK2). The field unit should be carefully fitted so that the connectors mate correctly. The actuator internal wiring harness connects the field unit at SK3 to the Modbus highway via the actuator terminal bung. The connector is polarised to prevent incorrect connection.

In the IQ3, the field unit can be fitted directly to the Control Module PCB using one of the 2 slots available or can be fitted on top of another option module that may already be fitted in one of these slots. There are 4 available slots for option cards to be mounted either directly or indirectly behind the Control Module PCB.

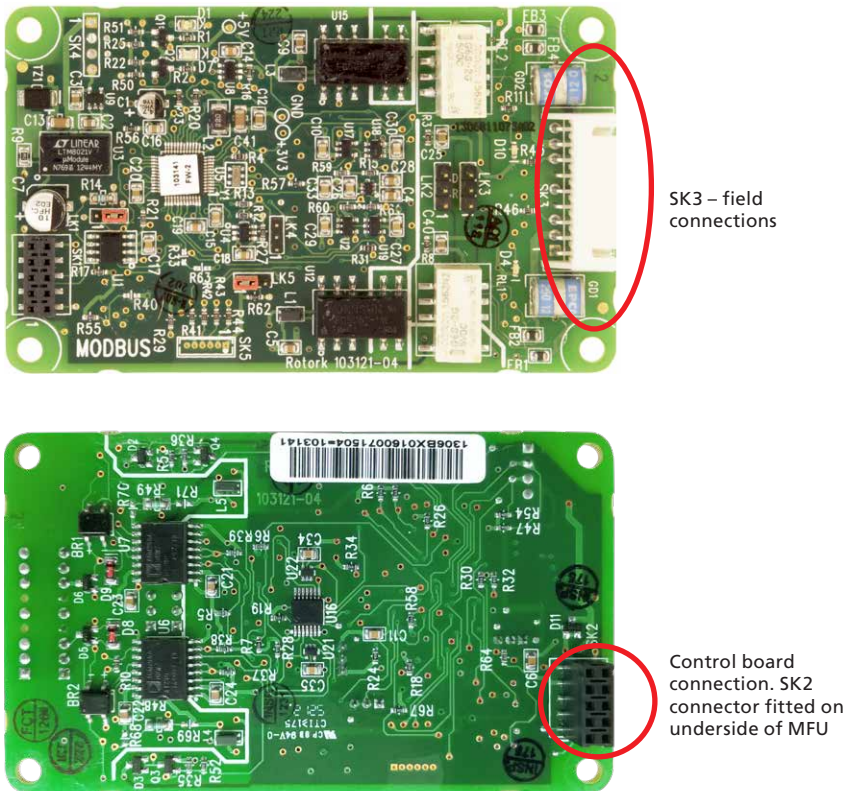

Fig 2: The Modbus Field Unit

2. Modbus option card properties *continued*

2.2 Electrical properties

The MFU processor circuits communicate with other modules in the actuator via an internal communications bus. The MFU does not sit in the main control path for the actuator and does not affect the actuator control integrity. The MFU processor contains the firmware for the unit. The firmware version is indicated on the label fitted to the processor. It can also be read from the actuator using the setting tool, by using Insight with Infra-red or by using Insight2 with Bluetooth, where appropriate.

Additionally, the circuit includes non-volatile memory that is used to store specific field unit communications settings.

The Modbus RS-485 fieldbus data highway connections are fully isolated from the actuator electronics.

2.3 Operation and storage

The MFU is designed to be stored in the actuator and operated within the same environment as the actuator. The constraints are:

- Operating temperature: -40 to +70 °C
- Storage temperature: -50 to +85 °C
- Relative humidity: 5% to 95% (<50 °C) non-condensing

3. Fitting the Modbus module option card

3.1 Inside an IQ3 actuator

The MFU is suitable for fitting into IQ3 actuators. When factory-fitted, their wiring diagrams will contain an 'M' - 100M2000 for single channel and 100M3000 for dual channel. The MFU can be located in one of 2 or 4 option 'slots' located on the back of the control module PCB, housed in the electrical cover. There are 2 slots for directly connecting the option module to the control module and where those slots are already filled, the option card can be fitted on top of the existing modules. The modules can be stacked 2 high where a 'deep' electrical cover is fitted.

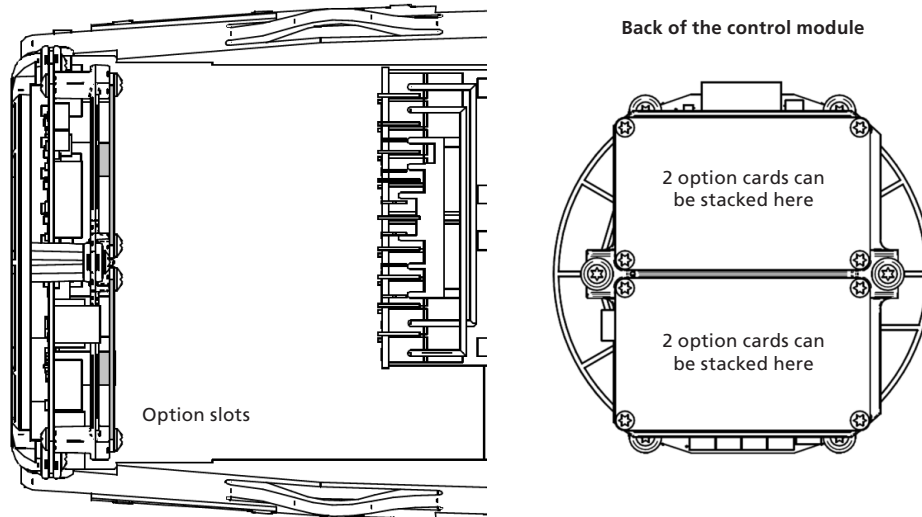

Fig 3: MFU location in the control module of an IQ3

With the IQ3 actuators, the remote inputs are always present (they are conditioned by the control board) and there is an option to include Digital Outputs from relay contacts. If the MFU is required to operate the 4 digital outputs that can be controlled from the card, then an Extra Relay Indication card associated with these outputs must be fitted into another option slot in the actuator.

The MFU is connected to the control module by a 10 way header (SK2). The wiring harness from the actuator terminal bung connects the Modbus RS-485 field connections to SK3.

3. Fitting the Modbus module option card *continued*

3.2 Replacing or fitting a Modbus module option card

The MFU should be replaced or fitted only in a suitable environment. The actuator must be made electrically safe before opening any covers. The electrical housing cover should be removed after unscrewing the four 6mm Allen machine screws. Unplug the electrical housing loom from the control board and remove the cover. Unplug the grey ribbon cable from the edge of the control board and unplug the black plastic carrier frame from the frame legs. Unplug the loom from the MFU card. Unscrew the Torx T20 screws holding the MFU card into the frame and carefully unplug the MFU card from the control board. The replacement board is fitted in the reverse order to removal. The wiring harness connectors are polarised so that only the correct one will fit its mating part on the circuit boards. Do not forget to re-connect the grey ribbon cable to the edge of the control board.

If the operation is to fit an MFU for the first time, then the necessary wiring loom must be added to the internal wiring harness of the actuator. The actuator wiring diagram shows the connectors and harness used. The wiring harness is fitted inside the actuator before attempting to fit the MFU. This requires that you remove the terminal bung, which is held in place by a large circlip. Be careful to attach the wiring loom to the correct terminals, which are numbered. Re-fit the terminal bung.

Once the loom is in place, connect it to the MFU, then fit the MFU to the actuator main board connector. Attach the MFU to the frame, using the Torx T20 screws.

Once the module is fitted, the actuator should be re-assembled.

Once power is applied, the field unit parameters should be checked and corrected, where necessary.

Modbus parameters can be set and adjusted either by using the Infra-red and Bluetooth setting tools or by Insight 2 using Bluetooth. The parameter setting procedure is covered by the IQ3 full configuration manual, [PUB002-040](#), available on the Rotork web site, www.rotork.com.

3. Fitting the Modbus module option card *continued*

3.4 Inside a CVA actuator

The single channel MFU is suitable for fitting into CVA actuators. When factory-fitted, the wiring diagram will be CXX-40 (where X can be any value). This details the option card connections to the terminal bung. The MFU module is fitted in the only option board slot inside the CVA electrical housing - on the underside of the Main PCB assembly. The MFU should be replaced or fitted only in a suitable environment.

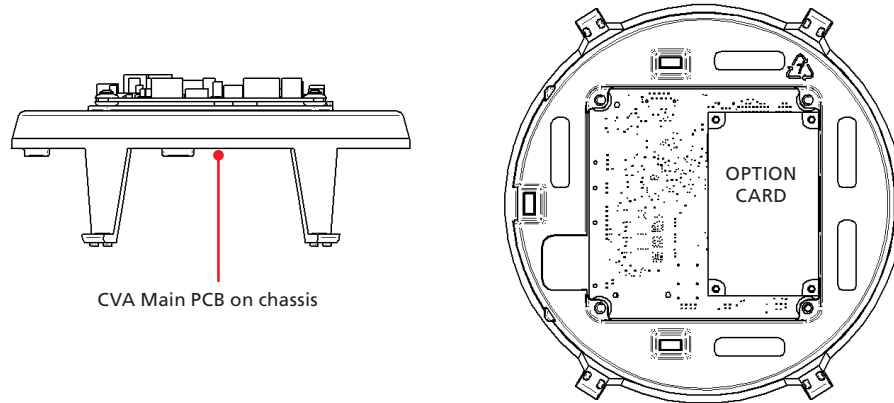

Fig 4: MFU location on the control PCB in a CVA actuator

To fit an MFU card, begin by removing power from the actuator and wait until the LED on the selector knob stops illuminating. This may take several minutes if a reserve power pack of capacitors is fitted.

Remove the six M10 machine screws from the upper cover and lift it off carefully, while removing its ribbon cable connector from the socket on the Main PCB.

Remove the various wiring looms from the sockets on the edges of the Main PCB, noting carefully where they attach. Each connector is different to avoid error.

Remove the Main PCB in its plastic chassis by gently pushing the chassis legs inwards to release them from a groove in the actuator housing.

Fit the MFU to the underside of the Main PCB using the hardware supplied with the MFU card.

The wiring loom from the actuator terminal bung connects the Modbus RS-485 field connections to SK3. If a new card is being fitted as an upgrade, then the actuator will need to have the loom fitted. Remove the terminal bung by removing the circlip and gently pulling the bung. Attach the loom and replace the bung.

The MFU is connected to the control module by a header, SK2.

The MFU in the CVA must be enabled. This would usually be done during the factory test but may be required to be completed on site for conversions to Modbus or if a replacement card is fitted. To enable the card, the Rotork PDA software Enlight (downloadable from the Rotork web site) is required to be used to change Parameter 34. It must be read and then 2048 decimal added to it.

This procedure is best performed by a Rotork engineer.

3. Fitting the Modbus module option card *continued*

3.5 Inside a CMA actuator

The MFU is suitable for fitting into CMA actuators, wiring diagrams MXX-MX (where X can be any value) detail the option card connections on the terminal strip. The MFU module is fitted in the only option board slot inside the CMA electrical housing.

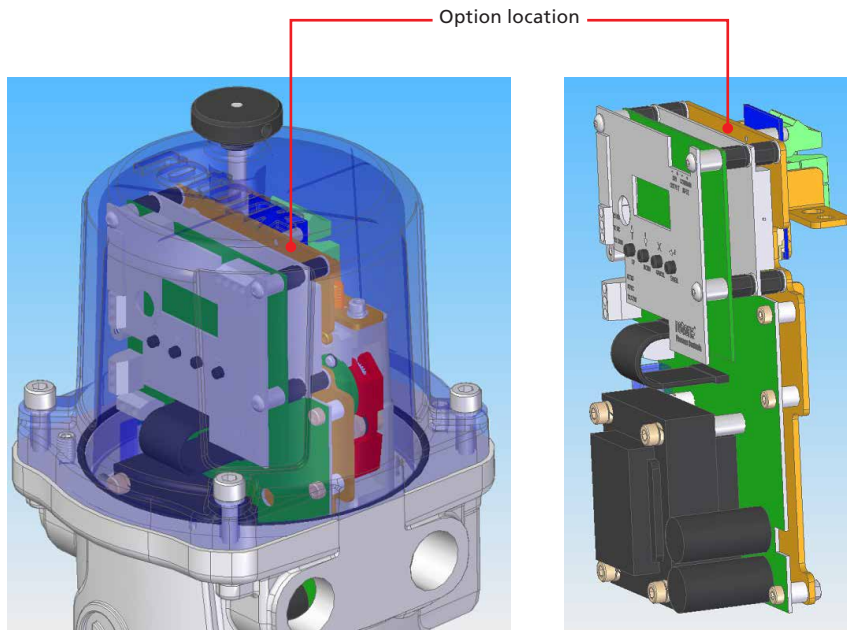

Fig 5: MFU location in a CMA actuator

Only the single channel Modbus option card can be fitted to this actuator family.

The MFU should be replaced or fitted only in a suitable environment. The actuator must be made electrically safe before opening any covers. The electrical housing cover should be removed after unscrewing the four 6mm Allen machine screws.

The MFU should be fitted in the position shown in the illustrations above. It plugs into the control board at the 10-way header, which is SK2 on the MFU board. There is a wiring loom which brings the RS-485 network connection to SK3 onto the MFU. This loom comes from SK5 and SK6 of the Modbus terminal board, which, in turn, is where the field network connections are made.

Connection details are shown in the illustrations on the next page.

The CMA actuator will need configuring, so that it is aware that control from the field is through the MFU card. This is done by accessing the menu structure shown in Figures 6, 7, and 8.

Configuration details may be found in the CMA Installation and maintenance manual, PUB094-003, available on www.rotork.com.

3. Fitting the Modbus module option card *continued*

3.5.1 CMA menu structure

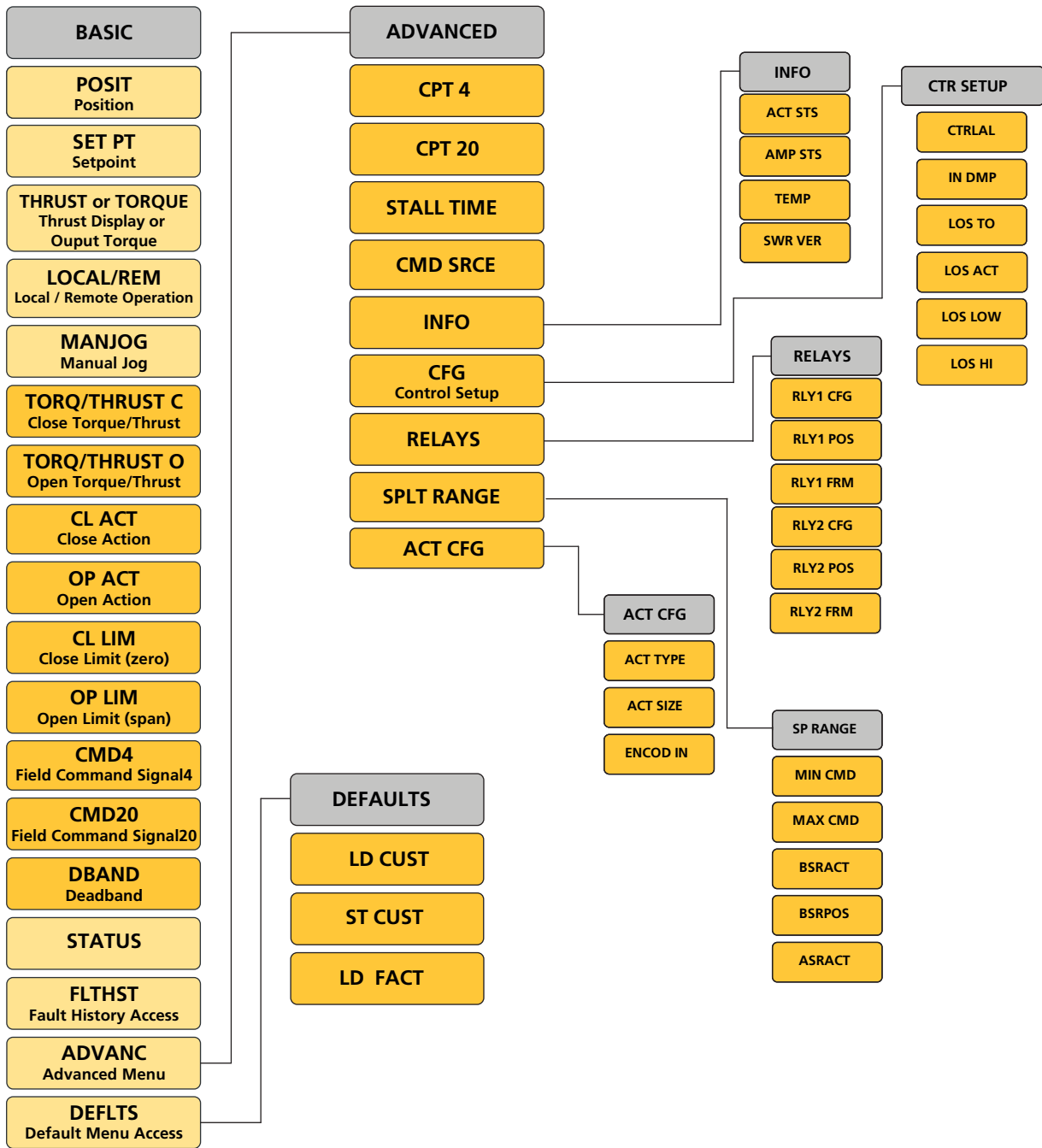

Fig 6: CMA menu structure for setting up the actuator: BASIC → ADVANC

3. Fitting the Modbus module option card *continued*

3.5.2 CMA advanced menu access

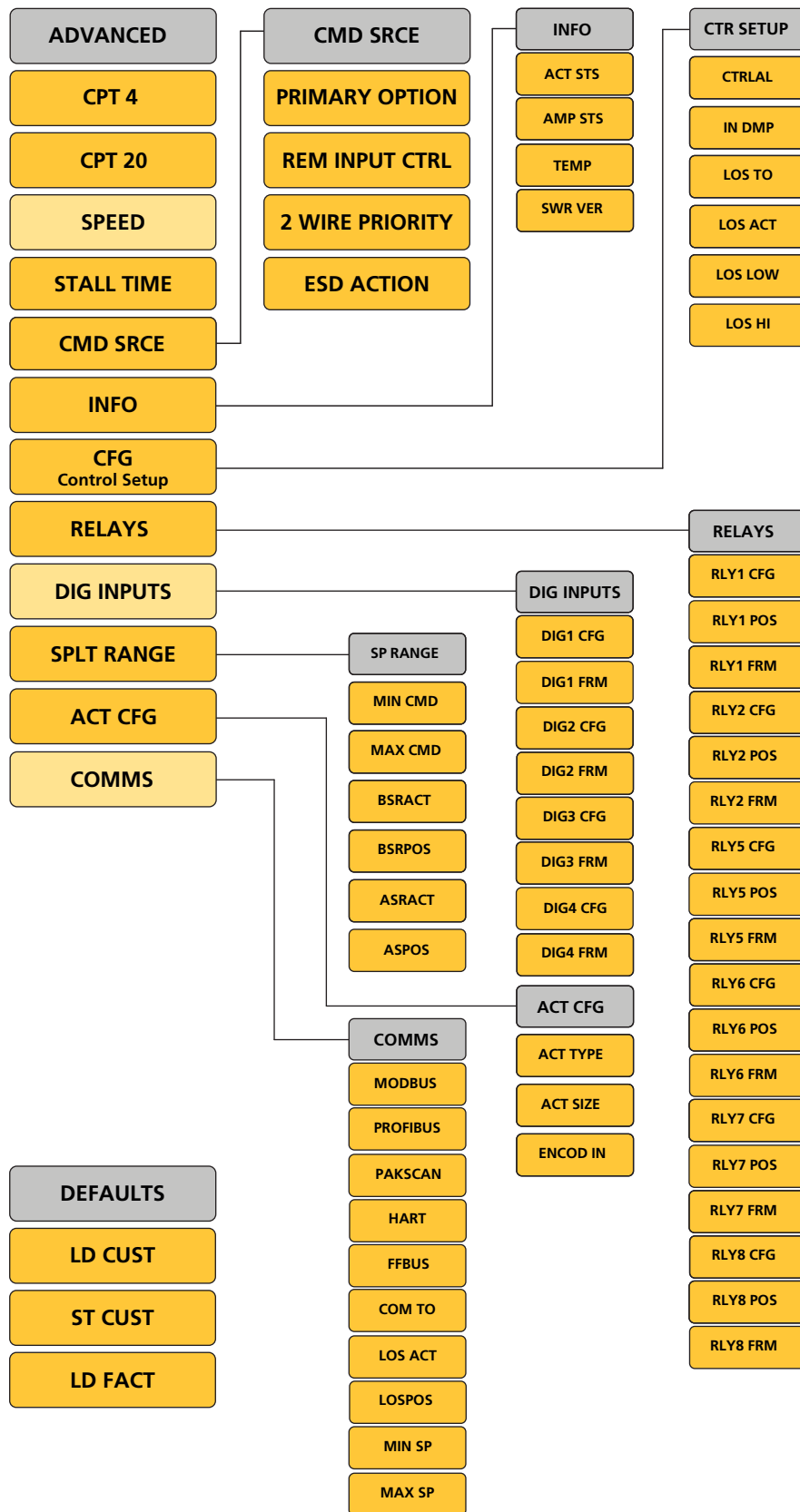

Fig 7: CMA menu structure for setting up the actuator: ADVANC → COMMS

3. Fitting the Modbus module option card *continued*

3.5.2 CMA advanced menu access *continued*

COMMS

COMMS - Bus option card configuration

The following menus appear automatically when a Bus option card is fitted.

For full details of each Bus option card and its menu settings please refer to the relevant technical manual.

MODBUS

- MODBD** **Modbus BaudRate**
- MODFT** **Modbus Field Type**
- MODAD** **Modbus Address**
- MODPR** **Modbus Parity**
- MODTM** **Modbus Termination**
- MOD2A** **Modbus Second Address**

- COMMS
- MOD BD
- MOD FT
- MOD AD
- MOD PR
- MOD TM
- MOD 2A
- PRO FT
- PRO AD
- PRO RP
- PRO RM
- PRO T1
- PRO T2

Fig 8: CMA menu structure for setting up the actuator: COMMS → MODBUS

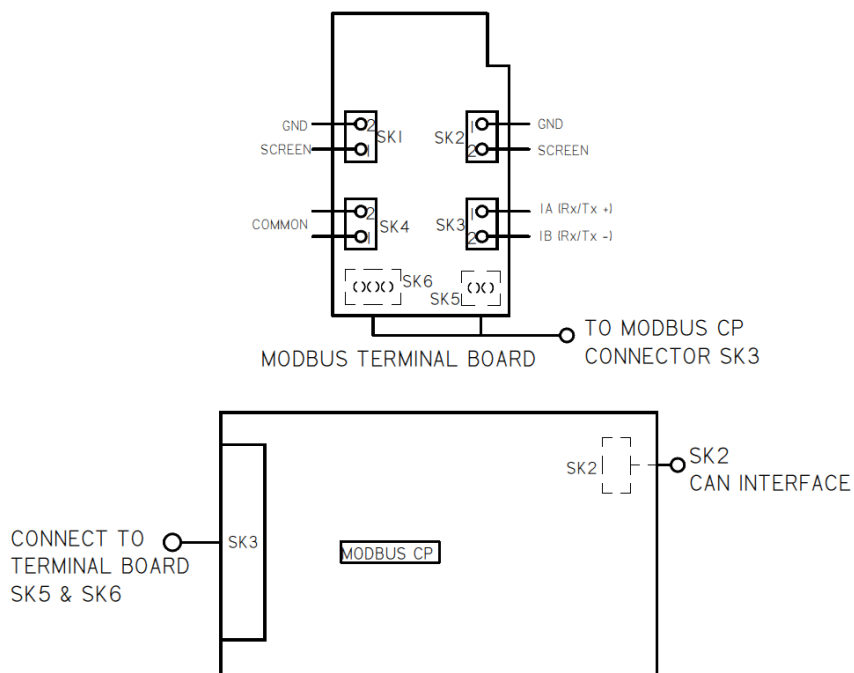

Fig 9: Connections to the MFU in a CMA actuator

3. Fitting the Modbus module option card *continued*

3.7 Inside a K-Range actuator

The MFU is suitable for fitting into K-Range actuators; wiring diagrams like 1612ZMD detail the option card connections. The MFU module is fitted in the only option board slot inside the K-Range electrical housing.

SK2 on the MFU card plugs directly onto SK9 on the Main card, while a terminal bung loom brings the network Modbus signals to SK3 (shown on right hand side of photograph) on the MFU card.

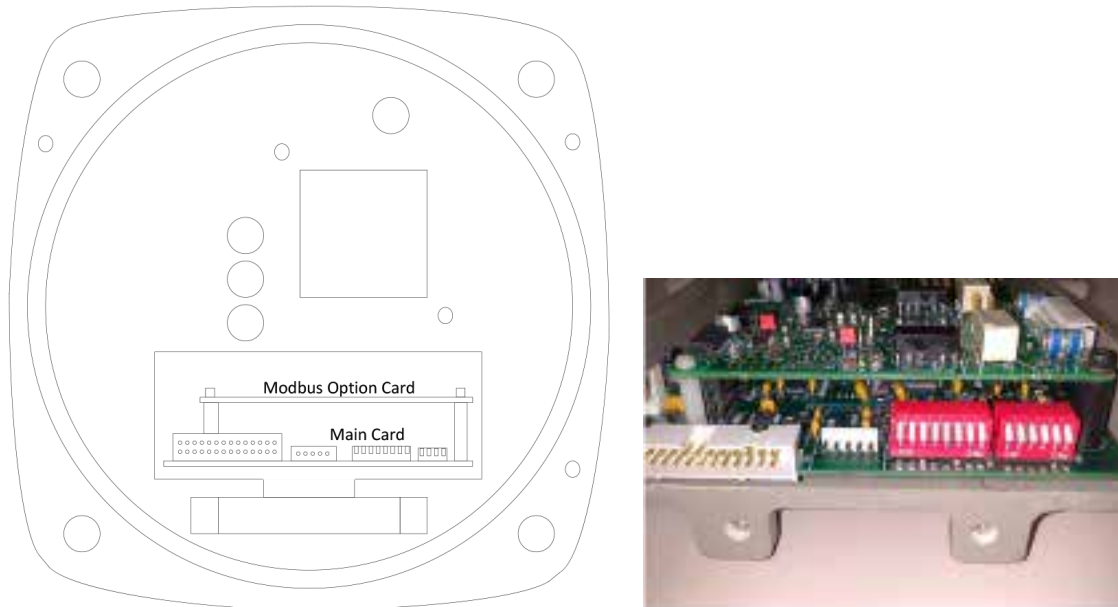

Fig 10: MFU location in a K-Range actuator

The MFU should be replaced or fitted only in a suitable environment. The actuator must be made electrically safe before opening any covers. The electrical housing cover should be removed after unscrewing the four 8mm Allen machine screws.

The MFU card is attached to the main card by three plastic pillars, with one metal pillar, Torx T20 screw and a fibre washer; as shown in the photograph above.

If an actuator is having the MFU fitted for the first time, then the terminal bung loom must also be fitted. The terminal numbers will be found in the appropriate wiring diagram, which should be included in the fitting kit.

4. RS-485 data highway, connections and MFU setup

4.1 Data highway

The MFU uses RS-485, 2-wire, half duplex, and Modbus RTU communications at various data rates. The rules governing the installation and connection of an RS-485 highway should always be observed to produce a successful installation. The RS-485 highway does not allow power to be transferred and the MFU is powered from the actuator itself. The MFU can only report data when the actuator or electronics module is powered up. (The actuator may have an auxiliary power supply attached, so that the actuator position can be reported even when the main actuator supply is removed).

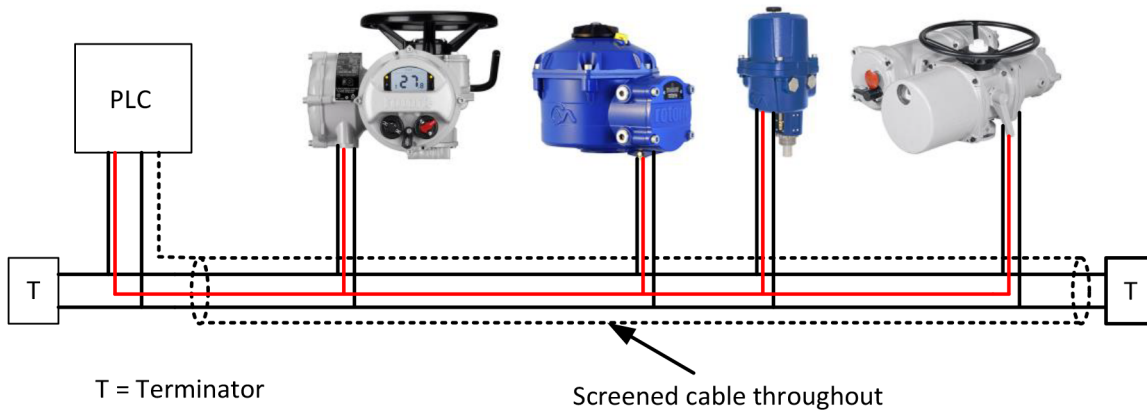

Fig 11: Typical RS-485 data highway

The data highway must be terminated with a resistor of 120 ohms at each end. One of the terminators must be an active termination. This requires a 5 volt DC power supply. The negative side of the supply is attached to the data negative wire by a 560 ohm resistor. The positive side of the supply is attached to the data positive wire by another 560 ohm resistor. Data positive is the wire which has a positive voltage on it compared to the data negative wire when a logic 1 pulse is on the highway.

The highway itself can use tapped spur or stub connections to the actuators, but it is recommended to keep any stub lengths to a minimum for successful operation. Alternatively, the connection can be made in and out of each actuator in a daisy-chain arrangement. The length of the highway and number of devices connected will vary from project to project. The Modbus standard permits up to 32 devices to be connected per segment, though one of these devices will be the PLC. If more devices are needed, (up to the maximum addressable of 247) then RS-485 repeaters may be added after each group of 32. The standard default address of the MFU is 247.

The length of the highway will determine the maximum speed of data transmission. Greater lengths are achieved at lower transmission speeds.

Although RS-485 requires only 2 wires for data transmission, the Modbus standard also requires that all the nodes on the network have a maximum common mode differential of -7 to +12 volts. This requires the ground potential at all points to be within the -7 to +12 volt limit. If the equipment is distributed over a wide area, or an area with poor ground conductivity, it may be necessary to connect a third wire between all the nodes. Most successful installations use 3 wires and for this, Rotork provides a 'common' terminal on the actuator. The common wire is shown in red above in Figure 9.

With RS-485 the data passes over a single 2-wire cable, but the Modbus protocol is such that there are periods between messages when no devices are actively driving the lines. In order to ensure that data continues to flow correctly after these periods, it is advisable to ensure the lines are biased to suitable voltage levels during the time the line is idle. This is usually achieved by biasing at the PLC, which forms the active terminator. The MFU does not contain biasing components and therefore requires biasing to be made externally. If the PLC does not do the biasing, then an active terminator must be fitted to the network highway and it will provide the necessary biasing.

4. RS-485 data highway, connections and MFU setup *continued*

4.2 Highway topology

Two different connection topologies can be used for RS-485. The first system is to use a trunk line with various spur lines from it. This system will require the location of the taps in junction boxes near to the actuators. With the second, the actuators can be directly connected to the trunk line in a daisy-chain. All the configurations require the cumulative total of the stub lines to be kept within the permitted maximum for the network speed to be used. A combination of both topologies may be used. Topologies, such as ring and star are non-standard and should not be used with standard Modbus hardware. However, a ring network can be achieved using the single channel with repeater hardware.

It is good practice to avoid spur lines wherever possible.

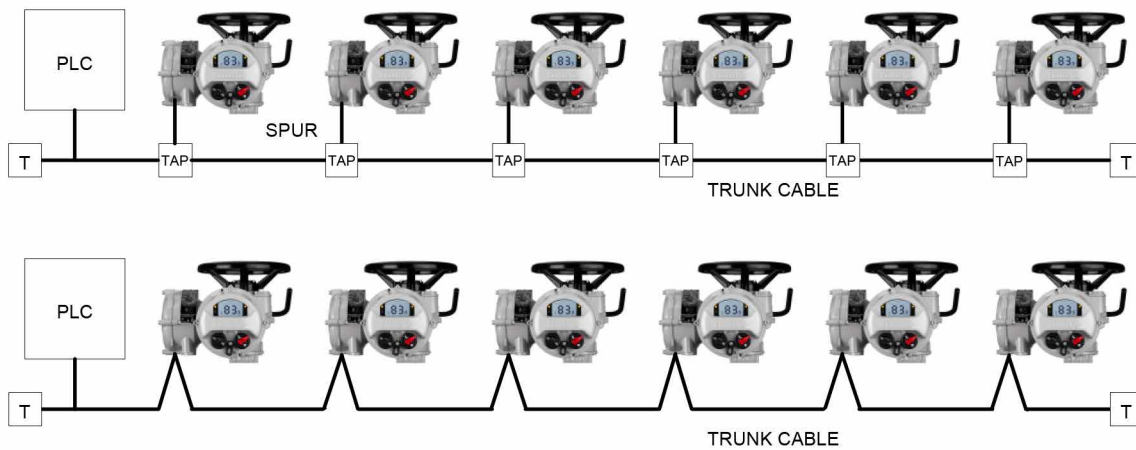

Fig 12: RS-485 data highway topology

The maximum trunk length, length of each spur and the cumulative total are dependent on the system data rate in use. The table below suggests the maximum figures for copper cable. The segment length is the total of the trunk and all the spurs added together.

Data rate (baud)	Maximum segment length (m)	Total spur length (m)
9,600	1,200	500
19,200	1,200	500
38,400	1,000	300
57,600	750	200
115,200	500	100

Within each actuator there is a short drop line or stub connection wire from the terminals to the MFU itself. This length must be included in any calculation for total and individual drop lengths. A more robust network generally has cable length (metres) times data rate (bits per second) less than 10 million.

Actuator internal spur length as in the table below:

Actuator type	IQ3	SI3/S14	CVA	CMA	K-Range
Internal drop length (metres)	0.6	0.6	0.4	0.14	0.4

If greater distances are required for the network, then the actuators can be operated at lower baud rates of 300, 600, 1,200, 2,400 or 4,800 baud. Alternatively, the distances can also be increased at the higher data rates by using repeaters or fibre-optic links between the devices on the network.

4. RS-485 data highway, connections and MFU setup *continued*

4.3 Cable types

The network must be connected using a suitable cable. Two conductors plus a shield and drain wire are required as a minimum, though Rotork recommends the use of a 3-wire cable to ensure the common mode voltage between all the actuators and the PLC is kept within the RS-485 specified limits.

Among the cable manufacturers, Belden have the PVC-jacketed 3105A single pair 2 core cable, which meets the minimum requirement. Belden 3106A has an extra core and therefore has sufficient conductors to include a common wire between all the nodes on the network and meets the Rotork recommendation. Information on Belden cable may be found on the Belden web site (www.belden.com) or at <http://bwcecom.belden.com/>, where a search on RS-485 will reveal technical papers and cable information.



Belden part no.	Total number of conductors	AWG (stranding) dia. inches	Nom. DC resistance	Insulation material	Nominal O.D.	Nom impedance (ohms)	Nominal capacitance
3105A paired - EIA industrial RS-485 PLTC/CM	2	22 AWG (7 x 30)	48.2 ohm/km	Overall PVC jacket Datalene insulated twisted pair	7.26 mm	120	36.1 nF/km
3106A composite - EIA industrial RS-485 PLTC/CM	3	22 AWG (7 x 30)	48.2 ohm/km	Overall PVC jacket Datalene insulated twisted pair	7.67 mm	120	36.1 nF/km

Fig 13: Typical RS-485 cable

Other cable manufacturers also produce suitable cables for Modbus networks. The quality of the Modbus network will largely depend on the cabling choices made during planning; and quality of installation. Cables for European installations must comply with the Construction Products Regulation.

The terminals to which the wires connect in each actuator type will be different and the actuator wiring diagram must be consulted to establish the connections.

4.4 Termination network

In order to operate correctly, all RS-485 highways must be terminated at each end of the main trunk line using a suitable resistor (120 ohm nominal, half Watt rating). These will usually be near the scanner PLC and near the last actuator. The resistors are connected between data line A and data line B. If the termination resistors are not fitted there is a possibility that the network communications will be unsatisfactory due to signal reflections.

One of the terminations must be active, using biasing resistors. These resistors put a known voltage across the data highway, so that there is a fixed state when none of the devices on the highway is transmitting. Without the active termination, there may be some communications errors.

The value of the biasing resistors must be between 450 Ω and 650 Ω .

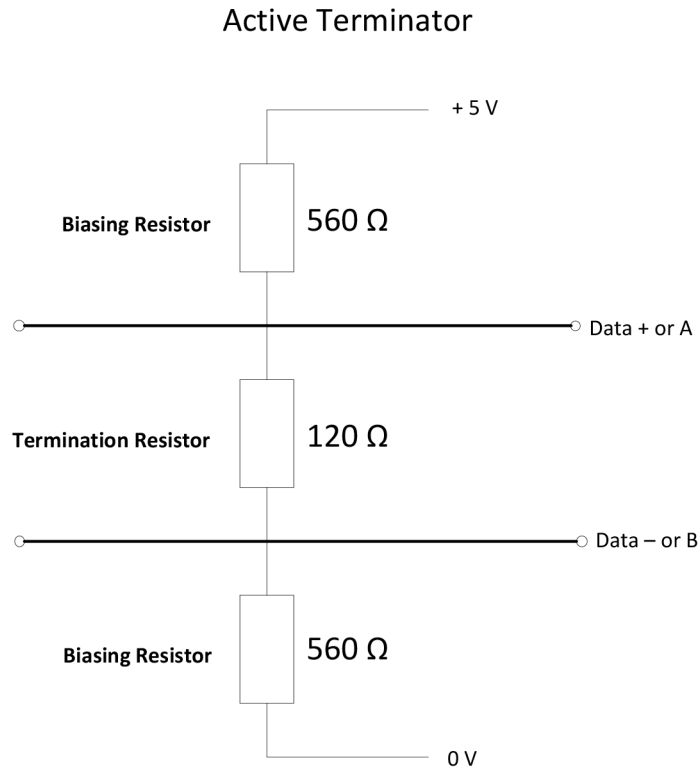

Fig 14: Active termination for RS-485 highway. Biasing resistor values are typical.

The MFU has an internal termination resistor which does not require any external wiring to be included (unlike the previous version of Modbus field unit). The termination resistor, or resistors for a dual channel, can be electronically switched on through the setting menu within the IQ3.

Termination may also be switched on and off in all actuator types where the MFU is fitted, through the network, by writing to Register 25 and setting it to 1 for ON and to 0 for OFF. Switching termination on in a dual card will result in both channels being terminated.

Termination is passive (with no biasing resistors) on the single and dual channel MFU cards. The biasing resistors are fitted to the single channel-and-repeater MFU card, so that the termination is active when enabled.

When power is removed from the actuator, the termination network(s) is no longer connected across the data highway. For this reason, we suggest a separate external active terminator is used on the highway at one end or the other of the main trunk line.

Note: When using the single highway with internal repeater the termination should always be fitted (or selected) on both sides of the repeater, since it will be the beginning and the end of a highway segment. Each terminator on the repeater is biased on the card.

4.5 Inter-connecting the highway and setting up the MFU

The three MFU variations (single, dual and single repeater) allow for various different highway connections. The 'single channel version' can be used for simple highways. The 'dual channel version' is used for redundant highway applications, where the highway integrity is important and the 'single-highway-with-repeater version' can be used for applications where distances are extended beyond the values listed on page 20 or where a ring type topology is desired.

4.5.1 Single highway

With the single channel option the actuator is connected to only one highway. The connection of the actuator to the highway uses terminals 1A and 1B. The terminal numbers depend on the actuator type and are indicated on the actuator wiring diagram. Take care to ensure that the correct polarity is observed on the data highway connection.

- Data line 1A is positive with respect to data line 1B when the MFU is transmitting a '1'.

There are no links or settings required on the MFU card when this version is being used.

4.5.2 Dual highway

The actuator can be connected to two highways when redundant communication links are required. The connection of the actuator to the highways uses Terminals 1A and 1B for Highway 1 and 2A and 2B for Highway 2. The terminal numbers depend on the actuator type and are indicated on the actuator wiring diagram. The last actuator on the highway should have the termination resistors switched on. Take care to ensure that the correct polarity is observed on each data highway.

- Each data line A is positive with respect to data line B when the MFU is transmitting a '1'.

The dual channel MFU uses a separate Modbus address for each channel, so it is possible to use the same address or different address on each channel. It is possible to communicate with both channels at the same time.

4. RS-485 data highway, connections and MFU setup *continued*

4.5.3 Single highway with internal repeater

With this option, a single highway passes through the Modbus Module and an internal repeater regenerates the data signals. The input to output connection is also isolated and this then allows the next section of cable to reach the maximum specified distance and the number of connected devices on the section to be 32. Biasing and termination resistors will be required at all repeater connection points.

Each repeater has a small propagation delay (micro seconds), this should be taken in to consideration in systems design when using multiple repeaters – for example, when creating a ring network.

- Data line 1A is positive with respect to data line 1B when the MFU is transmitting a '1'.

The internal repeater supports data speeds from 300 to 115,200 baud.

The repeater operates in both directions such that communications that appear on Channel 1 will be repeated onto Channel 2, and communications that appear on Channel 2 will appear on Channel 1. If the message is addressed to a device, the message will both be repeated and processed by the Modbus Module. The reply will appear, only, on the channel side where the message came in, that is, a message received on Channel 1 will be repeated over to Channel 2 and once the message is processed the reply will appear only at Channel 1. This is to avoid issues in a ring network that may be caused by the same message being received at both ends of the ring.

Modbus Ring, using Rotork K-Range and HIMax controller

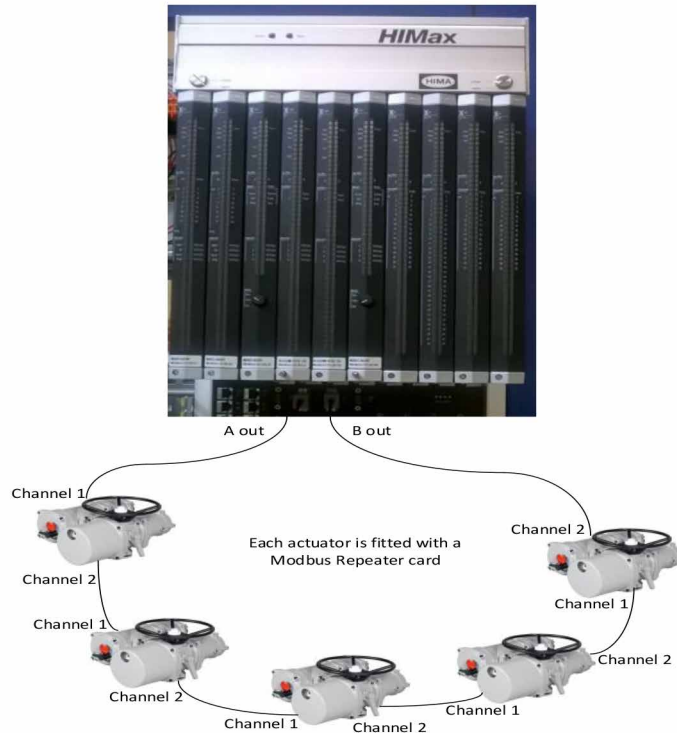

Here is a typical Modbus ring configuration. The PLC normally communicates with all the actuators on the A out channel. If there is a break or short-circuit in the cable between any of the actuators, the B out channel will communicate with the actuators beyond the damaged cable.

5. The actuator input and output signals

The MFU allows the actuator to be controlled by, and to report data to, a suitable host device using Modbus RTU protocol. This section explains the data signals that are available for exchange and their meaning in relation to the actuator functionality. The data locations used for the Modbus registers and coils are given later in this manual.

This section also gives information on the other control inputs available for moving the actuator.

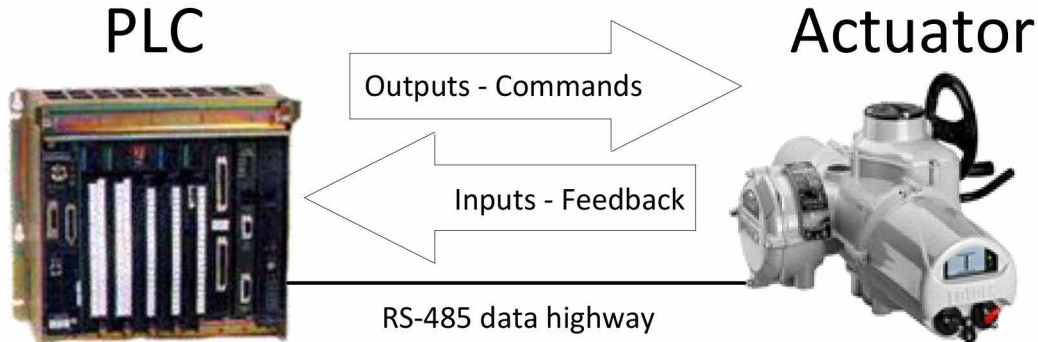

Fig 15: Input and output data direction

- Inputs are defined as signals originating at the actuator and fed back to the PLC over the RS-485 network, that is, inputs to the PLC.
- Outputs are defined as signals originating at the PLC and operating the actuator controls, that is, outputs from the PLC.

5.1 Control outputs

The MFU can be used to control the actuator to position the valve. The valve may be moved fully closed, fully open or to an intermediate position. Additionally, the actuator can make the valve adopt an Emergency Shut Down position or perform a partial stroke test. The actuator may also be operated from its local controls, by hardwired direct contact inputs, or by the handwheel, where fitted. In the case of hardwired control, the Auxiliary Input Mask and control source must be correctly set.

A description of the Auxiliary Input Mask and how to set it correctly is given in the IQ3 full configuration manual, [PUB002-040](#), available on the Rotork web site, www.rotork.com.

See also Section 8.1.5 for a similar explanation.

As well as controlling the actuator, the MFU can also be used to operate 4 discrete output relays when the Digital Input / Output card is also fitted within the actuator.

5. The actuator input and output signals *continued*

The control commands have three potential sources:

- Modbus RS-485 network generated commands
- Actuator local controls
- Direct contact input controls

The full list of commands is shown in the next table.

Command	IQ3	SI3/SI4	CVA	CMA	K-Range
Modbus over the network					
Open	✓	✓	✓	✓	✓
Close	✓	✓	✓	✓	✓
Stop	✓	✓	✓	✓	✓
Emergency Shut Down	✓	✓	✓	✓	✓
Relay output DO-1	✓ ^①	✓ ^①	✗	✗	✗
Relay output DO-2	✓ ^①	✓ ^①	✗	✗	✗
Relay output DO-3	✓ ^①	✓ ^①	✗	✗	✗
Relay output DO-4	✓ ^①	✓ ^①	✗	✗	✗
Analogue Position Demand	✓	✓	✓	✓	✓
Partial Stroke Test	✓	✓	✗	✗	✗
Local Controls					
Open	✓	✓	✗	✗	✓
Close	✓	✓	✗	✗	✓
Stop	✓	✓	✓	✗	✓
Direct Hardwired Inputs					
Open	✓	✓	✗	✗	✓
Close	✓	✓	✗	✗	✓
Stop/Maintain	✓	✓	✗	✗	✓
Emergency Shut Down	✓	✓	✗	✗	✓
Open Interlock (active prevents opening)	✓	✗	✗	✗	✓
Close Interlock (active prevents closing)	✓	✗	✗	✗	✓

Note: ^① – Requires Digital Input / Output card or Extra Relay card to be fitted

The Modbus network commands for Open, Close and Stop will operate the actuator provided:-

- Local/Local Stop/Remote selector is in 'Remote',
- Modbus commands are not inhibited by the 'Inhibit/DI-4' input parameter setting and DI-4 condition,
- No interlock is active,
- There is no standing hardwired control input active, except for Stop/Maintain,
- No alarm condition prevents it from moving,
- The Hand/Auto lever is not locked in Hand. If locked in Hand, this will cause a Valve Jammed or Valve Obstructed alarm.

5. The actuator input and output signals *continued*

- **Open** A digital command to cause the actuator to open to the fully open position, as indicated by the Open limit switch. Under correct operation, without either stalling or jamming, the actuator stops either when the open limit switch is reached, when the torque exceeds the value set and the open limit switch has been reached, or a new command is sent over the network. An alarm condition arising during travel will also cause an unexpected stop of actuator movement.
- **Close** A digital command to cause the actuator to close to the fully closed position as indicated by the Close limit switch. Under correct operation the actuator stops either when the close limit switch is reached, when the torque exceeds the value set and the close limit switch has been reached, or a new command is sent over the network. Similarly, an alarm condition arising during travel will cause an unexpected stop of actuator movement.

Note: Many multi-turn actuators are set to open until the open limit switch is reached and closed until the torque switch trips. This is appropriate for wedge gate and globe valves. The actuators can be set to open or close on limit or on torque.

- **Stop** With no other command present this digital command causes an actuator motor that is running, to stop.
 - **Emergency Shut Down (ESD)**

A digital command that causes the actuator to drive to its Emergency position. There are settings within the actuator to configure this to be a close, open or stay-put action. It may also be switched off.

The ESD command can be configured to override Thermostat trip, Interlocks and Local Stop. **Danger: Actuator hazardous area certification is invalidated while the thermostats are bypassed.**
 - **Relay Output DO-1 to DO-4**

These 4 commands are used to energise and de-energise the internal relays on the additional relay board. (These outputs are referred to as S5-S8 in the standard actuator documentation when there is no MFU in the actuator.) The resulting outputs can be used for operating other external equipment such as a pump or indication light. The IQ3 actuator is not able to control these relays directly from the main board when the MFU is fitted. They will maintain their last state if power is removed from the actuator. On restoration of power the relays will be reset to their de-energised condition and the coils will report '0'.
 - **Analogue Position Demand**

The source of this function is only over the Modbus RS-485 network. (Where multiple network cards or Folomatic is fitted, then this could be another source of positioning control). To initiate Analogue Position Control a value must be written to the Position DV register (range 0-100.0%, resolution 0.1%). The valve will open to the appropriate amount and stop in that position (within the deadband setting). It then drops out of the positioning mode. If a subsequent digital command to open or close the valve is issued, from any source during the travel to the setpoint, this will take priority over the analogue position command. Once the setpoint is reached the positioning controller is switched off. A new write to the Position DV register will initiate positioning mode once more, provided the desired value is beyond the deadband setting. The register location is listed later in this manual.

Provided limited range positioning is not invoked, the values 0% and 100% written to this register produce a special case output where the command is revised so as to fully close the valve to its tight shut off position (0%) and fully open the valve (100%). This is useful for the valve types mentioned in the note on the previous page.
 - **Hard Wired Open** The hard wired Open input will cause the actuator to run to the open limit if there are no alarm conditions or local controls active and the Auxiliary Input Mask is set to an appropriate value. The input can be either high or low, depending on the value of the Mask setting.
 - **Hard Wired Close** The hard wired Close input will cause the actuator to run to the closed limit if there are no alarm conditions or local controls active and the Auxiliary Input Mask is set to an appropriate value. The input can be either high or low, depending on the value of the Mask setting.
 - **Hard Wired Stop** The hard wired Stop input acts as a change of state input. If the actuator is moving, opening the Stop input will stop the actuator. If the Stop input is already open and a Modbus command is sent to the actuator, the Modbus command will be initiated. To stop the actuator the hard wired input must be closed and opened again.
 - **Hard Wired ESD** The hard wired ESD input will cause the actuator to move to its Emergency Shut Down position, which may be to stay put, go open or go closed. The ESD may also be switched off.
- The ESD command can be configured to override Thermostat trip, Interlocks and Local Stop. **Danger: Actuator hazardous area certification is invalidated while the thermostats are bypassed.**

5. The actuator input and output signals *continued*

In the case of the DO-1 to DO-4 relays, they will follow the command, energising when turned on and de-energising when turned off. These relays also maintain their status if the actuator power is removed and reset to the de-energised state only when the power is restored.

5.1.3 Modbus control using the ACTCON register

A single register is provided to allow the digital control of the actuator. Writing a value to the register with function code 06 or 16 causes the actuator to open, close, stop, ESD or partial stroke test and at the same time cancels any other command set. This method of control removes the need to reset commands written with a code 05 coil write with a second write to the same location. The number written changes any coil states already set to the new value. Values of 5 to 255 cause no actions.

ACTCON register (Register 5)					
Value	Stop	Close	Open	ESD	Partial Stroke
0	✓	✗	✗	✗	✗
1	✗	✓	✗	✗	✗
2	✗	✗	✓	✗	✗
3	✗	✗	✗	✓	✗
4	✗	✗	✗	✗	✓

5.1.4 Modbus control using the Actuator Position DV register

The analogue position control function will take priority over an earlier coil or ACTCON register command to open, stop, close, ESD or partial stroke test the actuator when a value is written to the Actuator Position DV register. The controller will then position the actuator to the desired value.

The analogue position control function is cancelled either by the actuator achieving the desired position or a coil or ACTCON register write to one of the open, stop, close, ESD coils.

Note that when limited range positioning is used and the actuator is in the fully closed position a DV value of 0%, or when the actuator is in the fully open position a DV value of 100%, are not acted upon.

5.1.5 The IQ3 'S' contacts (Modbus DOs)

The IQ3 actuator has four 'S' contact outputs that may be configured to report the status of the actuator with signals such as Open Limit, Closed Limit etc. These are identified as S1 to S4.

In addition, an optional extra relay board can be fitted with four more relays. The status of these relays is then adjusted by Modbus commands on outputs DO-1 to DO-4. Note that these relays are latching and, if energised, will not change state when the actuator power is removed. On restoration of power the relays will be reset to their de-energised condition and the coils will report '0'.

5.1.6 IQ3 Modbus network control disable feature

It is possible to set the IQ3 ESD/DI-4 input so that the actuator ignores open, stop, close, ESD, partial stroke test and position control signals sent over the Modbus network. If the ESD DI-4 / Net Disable parameter is set to Active, then when the ESD input connection is made (that is, 24 volts applied to ESD), Modbus control is not allowed. This feature is independent of the Auxiliary Input Mask setting. When the ESD DI-4 / Net Disable parameter is set to active, no ESD will be available.

5. The actuator input and output signals *continued*

5.2 Actuator digital input status feedback

The Modbus Module can report over the network a comprehensive data set relating to the status of the valve and actuator, as indicated in the table below. The conventional contact indications are also available from the actuator limit switches and indication contacts.

Status Feedback	IQ3	SI3/SI4	CVA	CMA	K-Range
Actuator Moving	✓	✓	✓	✓	✓
Close Limit	✓	✓	✓	✓	✓
Open Limit	✓	✓	✓	✓	✓
Running Closed	✓	✓	✓	✓	✓
Running Open	✓	✓	✓	✓	✓
Remote selected	✓	✓	RUN	✓	✓
Local Stop selected	✓	✓	STOP	✓	✓
Local selected	✓	✓	①	✓	✓
Thermostat Tripped	✓	✓	④	✓	✓
Monitor Relay	✓	✓	✓	✓	✓
Valve Obstructed	✓	✓	✓	✓	✓
Valve Jammed	✓	✓	✓	✓	✓
Valve Moving by Hand	✓	✓	✓	✗	✓
Moving Inhibited	✓	✓	✗	✗	✓
Position Control Enabled	✓	✓	✗	✓	✓
Watchdog Recovery	✓	✓	✗	✗	✗
Battery Low	✓	✗	②	✗	✗
Open Interlock input	✓	✗	✗	✗	✓
Close Interlock input	✓	✗	✗	✗	✓
DI -1	✓	✓	✗	✗	✓
DI -2	✓	✓	③	✗	✓
DI -3	✓	✓	✗	✗	✓
DI -4	✓	✓	✗	✗	✓

Note ① Manual control using Enlight.
Note ③ UPS in Use.

Note ② UPS Fault.
Note ④ Thermostat is tripped when CVA is set to hand operation.

5.2.1 Digital Inputs from the actuator

- Actuator Moving** Whenever the actuator position is changing due to the motor running or if the output drive is moving, this bit will be set true (1).
- Close Limit** This data bit indicates that the actuator has reached the closed position. The limit switch should be set slightly within the actual valve stroke to allow for torque seating or overshoot on closing without damaging the valve. The data bit will remain true (1) even if the position is passed through or exceeded.
- Open Limit** This data bit indicates that the actuator has reached the open position. The limit switch should be set slightly within the actual valve stroke to allow for torque seating or overshoot on opening without damaging the valve. The data bit will remain true (1) even if the position is passed through or exceeded.
- Running Closed** This bit is true (1) whenever the actuator motor contactor used to drive the actuator in the closing direction is energised.
- Running Open** This bit is true (1) whenever the actuator motor contactor used to drive the actuator in the opening direction is energised.
- Remote Selected** This bit is true (1) when the actuator three position Remote/Local Stop/Local selector is in the Remote position. The selector must be in this position for Modbus control of the actuator to be permitted.
- Local Stop** The actuator three position selector passes from Local to Remote or Remote to Local through the Local Stop position. The switch can also be placed in Local Stop. When the switch is in the Local Stop position this bit will be true (1). Remote control of the actuator is not possible when the selector is in this position.

5. The actuator input and output signals *continued*

- **Local Selected** This bit is true (1) when the actuator three position Remote/Local Stop/Local selector is in the Local position. Remote control of the actuator is not possible when the selector is in this position.
- **Thermostat** If the temperature of the motor windings rises above the thermostat trip value, the thermostat contact will open and this signal will be present (1). There are no adjustments for the temperature at which the thermostat trip operates. The motor will be stopped if the thermostat trips. Only once the motor has cooled down and the thermostat has reset itself can a new Remote, Network or Local command to move the actuator be carried out. A setting on the actuator main board allows the ESD command to override the thermostat. The bit will remain set at logic 1 until the motor cools down and the thermostat resets itself.
- **Monitor Relay** This signal is true (1) when actuator remote control is not available. The actuator Monitor Relay status is a composite signal for several alarms. This signal will be set true if the actuator selector is in Local or Local Stop (not in Remote) or if the thermostat trips. The mains supply is also monitored and if one of the three phases is lost, this bit is set. If the actuator is operated from a single phase supply and this is lost, then communications with the actuator will also be lost. Where a 3 phase supply is used, if the phase associated with the control circuits is lost then communications with the actuator will be lost.
- **Valve Obstructed** This bit will be true (1) if the actuator stops in mid-travel when not expected to do so after receiving a command to move. If the actuator torque exceeds the trip value set during commissioning, then the motor will stop and motion will cease. The reason for the actuator stopping will be the high torque due to an obstruction and not to a 'Stop' signal or reaching the desired setpoint position.
The bit will remain true (1) until the actuator position changes by 2% or more.

Note: Attempting to restart the actuator to move towards the obstruction (even if the obstruction no longer exists) is not possible, as the actuator will not restart. The actuator must be electrically reversed away from the obstruction before attempting to continue in the original direction.

- **Valve Jammed** This bit will be true (1) if the actuator is stationary at the end of travel and fails to move away from the seat of the valve when a network command requests it to do so. The actuator will trip on excessive torque due to the valve being jammed in the seat. The MFU fails to see movement and reports this status after the time set in the associated parameter during the MFU set up.
The bit will remain true (1) until the actuator position changes by 2% or more.

Note: Attempting to restart the actuator to move out of the seated position is not possible. The actuator must be reversed before it will run in the same direction again. The jammed seat must first be released manually before electrical control is attempted. The problem may be overcome by adjusting the actuator torque setting, which is designed to provide extra power on leaving the seated position.

- **Valve Moving by Hand**
The manual movement of the valve is reported as true (1) if the actuator is moved by the handwheel away from the last position. The percentage of travel required to trip the indication is set in the associated parameter (Register 17) during MFU set up.
The bit will remain true (1) until the handwheel is again stationary.
- **Moving Inhibited** This bit will be true (1) when the Motion Inhibit Timer is active or the Interrupter Timer is active, or both are active.
- **The Motion Inhibit** Timer is used in position control to prevent the actuator from exceeding its prescribed number of starts per hour, or to reduce the effects of hunting during closed-loop control.
The Interrupter Timer can be used over part or the entire actuator stroke to slow down the effective speed of valve travel.
When under network control, the control signal does not need to be re-applied when this bit is true, as the control action will continue once the time has elapsed.
- **Position Control Enabled**
This bit will be true (1) when a Position command is being actioned. This data can be used to indicate that positioning mode has control of the actuator.

5. The actuator input and output signals *continued*

- **Watchdog Recovery** The MFU watchdog automatically resets the processor if it is tripped. This bit will be true (1) following a watchdog trip for the time period set in the associated watchdog timeout parameter (Register 18).
- **Battery Low** The status of the internal battery is monitored and should it fall below a critical level this signal will become true (1). The battery is used to power the circuits used to keep track of the valve position when the actuator mains power is lost. This battery is used only when the actuator has no power feed and the valve is actually moved.
- **Open Interlock** The input contact to the Open Interlock is monitored by the MFU. Whenever the input contact is closed this bit will be true (1). If the actuator is not using the interlock function, then this input can be used as a digital status feedback for a plant signal not associated with the actuator. If the interlock circuit is being used, then this bit will indicate the existence of an interlocking input that can prevent the actuator from opening.
- **Close Interlock** The input contact to the Close Interlock is monitored by the MFU. Whenever the input contact is closed this bit will be true (1). If the actuator is not using the interlock function, then this input can be used as a digital status feedback for a plant signal not associated with the actuator. If the interlock circuit is being used, then this bit will indicate the existence of an interlocking input that can prevent the actuator from closing.
- **Digital Input DI-1** This bit reports the status of the contact connected to the actuator hard wired **Open** terminals. The input can be used to control the actuator or simply to report the status of a plant feedback signal. The function is set in the Auxiliary Input Mask parameter which determines whether the bit is reported as true (1) for a closed contact or an open contact and whether the input controls the actuator or not. Note that the input is always reported, even when it is also controlling the actuator.
- **Digital Input DI-2** This bit reports the status of the contact connected to the actuator hard wired **Close** terminals. The input can be used to control the actuator or simply to report the status of a plant feedback signal. The function is set in the Auxiliary Input Mask parameter which determines whether the bit is reported as true (1) for a closed contact or an open contact and whether the input controls the actuator or not. Note that the input is always reported, even when it is also controlling the actuator.
- **Digital Input DI-3** This bit reports the status of the contact connected to the actuator hard wired **Stop/Maintain** terminals. The input can be used to control the actuator or simply to report the status of a plant feedback signal. The function is set in the Auxiliary Input Mask parameter which determines whether the bit is reported as true (1) for a closed contact or an open contact and whether the input controls the actuator or not. Note that the input is always reported, even when it is also controlling the actuator.
- **Digital Input DI-4** This bit reports the status of the contact connected to the actuator hard wired **ESD** terminals. The input can be used to control the actuator or simply to report the status of a plant feedback signal. The function is set in the Auxiliary Input Mask parameter which determines whether the bit is reported as true (1) for a closed contact or an open contact and whether the input controls the actuator or not. Note that the input is always reported, even when it is also controlling the actuator.

A configuration feature also allows DI-4 to be set to act as a 'Disable Fieldbus Control' input. In this mode, when the input is made (irrespective of the Auxiliary Mask setting), the actuator cannot be controlled over the network. This can be useful during plant commissioning to prevent unwanted valve movement.
- **Control Contention** This bit will be true (1) if there is more than one actuator control bit active. For example, if more than one of coils 0, 1, 2, 3 or 8 have a value of 1.
- **Partial Stroke in Progress**

When the actuator is performing a partial stroke, this bit is true (1). Once the action is complete the bit is reset (0). If the partial stroke is interrupted by a new command, then the bit will be reset.
- **Partial Stroke Error** In order to perform a partial stroke of the valve, the starting position is specified as either the open limit or the close limit. If the actuator is commanded to perform a partial stroke when it is not in the correct starting position or when it is in a mid-position this error is generated and the bit will be set (1).

There is a timer associated with Partial Stroke that is set during parameterisation to a value long enough to cover a successful partial stroke operation from end to mid position and back to the end. If the actuator fails to complete the partial stroke within the time set then this bit will be true (1).

Once set, the Partial Stroke Error bit will be reset to 0 when the actuator next starts a partial stroke test.
- **General Alarm** General Alarm is any of the following: battery low/flat, valve alarm, actuator alarm, control alarm, valve jammed/obstructed, or monitor relay.

5. The actuator input and output signals *continued*

5.3 Actuator analogue input feedback

The Modbus Module makes several analogue variables available over the network. These contain information about the valve and actuator.

Analogue feedback	IQ3	SI3/SI4	CVA	CMA	K-Range
Actuator Instantaneous Torque	✓	✓ ^②	✓ ^①	✓	✗
Valve Position	✓	✓	✓	✓	✓

Note ① Torque on CVQ. Thrust on CVL

Note ② Pressure

- **Torque** The currently developed torque value is reported as an Integer Value in the range 0 to 120 (0-78 hex), representing the percentage of actuator rated torque generated.
- **Valve Position** The current valve position is reported as an Integer Value in the range 0 to 1000 (0 – 3E8 hex) representing the percentage position to 0.1% resolution.
The actuator automatically scales the valve position value reported from the setting of the limit switches.
If Limited Range Positioning is invoked by setting the appropriate parameters (8 & 9), then the reported valve position 0 to 100% follows the limited range of valve travel.

5.4 IQ3 data logger information

The Modbus Module also makes available some of the data logged information from registers in the database. The data available is updated when the actuator reaches the end of travel and stops moving, provided the actuator selector is in the 'Remote' position.

- **Close Torque Set** The actuator setting for the maximum generated torque value permitted when the actuator is moving towards the closed position is recorded in this register.
- **Open Torque Set** The actuator setting for the maximum generated torque value permitted when the actuator is moving towards the open position is recorded in this register.
- **Torque at x% when opening**
There is a set of registers that each record the last value for the torque generated when the actuator is moving from closed to open and reaches a position (x%). The registers contain 11 values of torque generated in 10% position increments between 0% and 100% of valve travel.
- **Torque at x% when closing**
There is a set of registers that each record the last value for the torque generated when the actuator is moving from open to closed and reaches a particular position (x%). The registers contain 11 values of torque generated in 10% position increments between 100% and 0% of valve travel.
- **Motor Starts – Closing Direction**
Two registers (one double register) contain the total number of times the motor contactor to close the valve has been operated. The first register contains the low order 16 bits. The counter cannot be reset to zero.
- **Motor Starts – Opening Direction**
Two registers (one double register) contain the total number of times the motor contactor to open the valve has been operated. The first register contains the low order 16 bits. The counter cannot be reset to zero.

6. Modbus communication

6.1 Electrical specification

Line Electrical Specification: RS-485, two wire, half duplex

6.2 Outer protocol

Modbus Transmission Mode RTU (8 bit Binary data)

Supported Baud Rates 300, 600, 1k2, 2k4, 4k8, 9k6, 19k2, 38k4, 57k6, 115k2

Number of bits per character

Start bits 1

Data bits (LSB first) 8

Parity (configurable) Odd, Even, None

Stop bits (configurable) 1 or 2

Error checking CRC

Message turn round time/delay time

Minimum period between request and response:

Data Speed (Baud)	300	600	1k2	2k4	4k8	9k6	19k2	38k4	57k6	115k2
Turn Round Time (ms)	188	100	60	40	28	24	20	20	20	20
Repeater Delay ^① (μs)	3.5	3.5	3.5	3.5	3.5	3.5	3.5	3.5	3.5	3.5
Inter-Character timeout (t _{1.5}) (ms)	55.04	27.52	13.76	6.88	3.44	1.72	0.860	0.750	0.750	0.750
Inter-frame delay (t _{3.5}) (ms)	128.3	64.16	32.08	16.04	8.02	4.01	2.00	1.750	1.750	1.750

^① – In the Single highway with Internal Repeater Modbus module option there is a propagation delay in the repeater.
Maximum period between request and response: 190 ms

6.3 Repeaters

A single segment supports up to 32 nodes, one of which is usually the PLC. The addition of repeaters allows the segment to be extended in length or to increase the number of nodes connected to the network, or both. The maximum lengths at different speeds are discussed in Section 4.2. The number of repeaters in a single highway should be kept to a minimum, as this can seriously extend the delay between a message being sent and the response arriving at the PLC.

The Single highway with inbuilt Isolating Repeater version of the Modbus module introduces propagation delays as mentioned above. Care must be taken in any system design to allow for these delays.

6.4 Dual channel mode

The dual channel version of the Modbus Module has two ports and allows two data highways to be used for communication from the host system to the module. These highways operate independently with a limit of 32 devices per segment and the ports on the module communicate with their associated highway. There is some interaction between the ports since a single processor serves them and the following points must be noted:

- The module only has one setting for the unit's communication speed and format. Both the comms ports share one set of common values for these parameters. The channels may have the same address or may be different.
- When communication is active, every device on the highway reads all the data request or command messages. Each unit then responds only to those messages aimed at its address.
- Port 1 has priority over Port 2. Since every message is read, the host system must allow an idle time on Port 1 to allow Port 2 time to read its messages completely.
- A minimum time gap equivalent to 11 bytes of data should be left between data requests on both highways. This will ensure that the processor has enough time to respond to messages directed at Port 2. Without this idle period messages directed at Port 2 may not be acknowledged and a response may not be generated.

7. Modbus database

The data in the Modbus module may be collected using several different Modbus function codes. Similarly, the commands to the MFU can be either register or discrete based. This inbuilt flexibility is designed to allow for any host device to be able to access the actuator over a Modbus network in the simplest way.

This section provides information on the function codes supported and the data that may be collected or commands issued using those codes.

In all cases, registers and discrete locations are numbered from 0 and do not include any offsets.

7.1 Modbus RTU message frame

Message synchronisation is maintained by stimulation; the receiving MFU monitors the elapsed time between receipt of characters. If 3 and one-half character times elapse without a new character or frame completion, then the next byte received will be the start of a new message, beginning with the address.

Modbus Address	Function Code	Register or Discrete Address	Number of Registers or Bits	Data Field	CRC Check
8 bits	8 bits	16 bits	16 bits	N bits	16 bits

Fig 17: Modbus transaction format

7.2 Modbus address

The Modbus module allows slave addresses in the range 1 to 247 to be used for devices. The addresses above 247 are reserved for special functions. Address 0 is recognised by all the slaves and is used for global Broadcast messages only. This leaves 247 addresses for use by the connected Modbus modules on the data highway.

Note that the dual highway unit can use a single address for both highway connections, or it can use two different addresses.

- Single RS-485 highway: Address range supported = 0 to 247 (0 for broadcast)
- Dual Independent Isolated RS-485 highways: Address range supported = 0 to 247 (0 for broadcast)
- Single RS-485 highway with inbuilt isolating repeater: Address range supported = 0 to 247 (0 for broadcast)

7. Modbus database *continued*

7.3 Function code support

Details of the Request and Reply formats for messages can be found in the Modbus Application Protocol Specification V1.1b3, found at <http://www.modbus.org>. The following table lists the function codes supported by the Modbus Module.

Function code	Modbus name	Addressing
01	Read Output Coil Status	Discrete
02	Read Input Status	Discrete
03	Read Holding Registers	Register
04	Read Input Registers	Register
05	Force Single Coil	Discrete
06	Preset Single Register	Register
07	Read Exception Status	
08	Loopback Diagnostic Test	
15	Force Multiple Coils	Discrete
16	Preset Multiple Registers	Register
17	Report Slave ID	

Exception response code	Meaning
01	Illegal function code or incorrect message length
02	Illegal data address (Register or discrete address invalid)
03	Illegal data value
06	Busy

To read data, the function code to use will depend on whether the data is to be read as single bits or as 16 bit registers. For example, code 01 reads data as discrete bits, whereas code 03 reads the data as registers. In many cases Discrete and Register access reads the SAME data.

- **Code 01 - Read Coils**

This is used to read discrete (bit) data from the database to obtain information about the status of the output coils (commands).

- **Code 02 - Read Input Status Requests**

This is used to read discrete (bit) data from the database to obtain information about the actuator current status, such as open or closed positions reached.

- **Code 03 - Read Holding Register Requests**

All the data in the MFU can be read using function code 03. Discrete data is mapped into registers that are available for this command.

- **Code 04 - Read Input Register Requests**

Actuator position and torque registers, plus the status bits, are accessible with function code 04.

- **Code 05 and 15 - Force Single Coil or Multiple Coils**

The output coils are the discrete outputs from the actuator or its digital control commands. Code 05 writes one coil per message while code 15 can write values to several coils at once.

7. Modbus database *continued*

- **Code 06 and 16 - Preset Single Register or Multiple Registers**

Registers are used for position control and digital control and can be accessed singly, or in multiples, with these codes. Function code 06 writes a single 16-bit register while function code 16 can write several registers in one transaction.

- **Code 07 - Read Exception Status**

This is a specific short message function code which returns predetermined discrete data from the MFU. The message is used to allow fast transfer of a small data packet of 8 bits. A description of the data is given in Section 7.6.7.

- **Code 08 - Loopback Diagnostic Test**

The purpose of the Loopback Test is to test the communication system between the Modbus Module and the host. This code can be regularly sent and used as a heartbeat to test the communications link. The MFU supports this test when used with diagnostic code 00, Return Query Data, and 02, Return Diagnostic Register. No other diagnostic test codes are supported. See Section 7.6.8.

- **Code 17 - Report Slave ID**

This function code generates a response that contains the software version of the MFU and actuator tag data. The tag data may be written by the customer over the network. 12 ASCII characters can be written in this area. See Section 7.6.9.

- **Exception Response Codes**

Error code 01 will be presented back to the host if the function code in the data message is not one of those supported by the Modbus Module or the message length is not as expected.

Error code 02 will be presented back to the host if the Data Address is not valid for the Modbus Module.

Error code 03 will be presented back to the host if the value to be written in a coil or register write is not valid for the register or coil location chosen in the MFU.

Error code 06 will be presented back to the host if the MFU is unable to respond with a correct message because it is busy.

7.4 Broadcast commands

Broadcast commands are only supported for specific registers, coils and commands.

- **Stop and ESD**

Code 05 writes to coils 0 (Stop) and 3 (ESD) are supported for address 0 broadcast.

Code 06 writes to Register 5 (Actuator Digital Control) with values 0 (Stop) and 3 (ESD) are supported for address 0 broadcast.

7.5 Data location offsets

The locations given in the database are those which should appear in the messages as they are transmitted on the Modbus link. Some host systems offset the addresses so far as the user is concerned. In such cases, the address programmed into the host would be different to those listed. All data locations listed start from 0. Please check the host system documentation carefully to determine if any offsets are required.

Typical offsets are:

Function code	Offset to be added to formulae result
01	1
02	10001
03	40001
04	30001
05, 15	1
06, 16	40001

7. Modbus database *continued*

7.6 Data locations

The data locations in the following tables are all numbered from 0. For a definition of the actuator functions listed refer to Section 5. For the DO-1 to DO-4 options, the extra relay output board must be fitted. This can only be fitted in IQ3 actuators.

Note: All data locations listed start from 0; it may be necessary to add an offset to match the number required for the PLC.

7.6.1 Data accessed with function code 01 – Read Coils

Location (Bit)	R/W	Data	Range
0	R/W	Stop command output coil status	0 - 1
1	R/W	Close command output coil status	0 - 1
2	R/W	Open command output coil status	0 - 1
3	R/W	ESD command output coil status	0 - 1
4	R/W	DO-1 output coil status (extra relay S5) ①	0 - 1
5	R/W	DO-2 output coil status (extra relay S6) ①	0 - 1
6	R/W	DO-3 output coil status (extra relay S7) ①	0 - 1
7	R/W	DO-4 output coil status (extra relay S8) ①	0 - 1
8	R/W	Partial stroke test	0 - 1
9	R/W	DO-5 output coil status (actuator relay S1 IQ3 only)	0 - 1
10	R/W	DO-6 output coil status (actuator relay S2 IQ3 only)	0 - 1
11	R/W	DO-7 output coil status (actuator relay S3 IQ3 only)	0 - 1
12	R/W	DO-8 output coil status (actuator relay S4 IQ3 only)	0 - 1

Note: Coil 'on' when the state is true, reports as a '1'.

Note ① DIO1 (IQ3) or RIRO1 (CMA) or Extra Relay board 1 must be fitted

7. Modbus database *continued*

7.6.2 Data accessed with function code 02 – Read Discrete Inputs

Location (Bit)	R/W	Data	Range
0	RO	Actuator moving	0 - 1
1	RO	Closed position limit	0 - 1
2	RO	Open position limit	0 - 1
3	RO	Running closed	0 - 1
4	RO	Running open	0 - 1
5	RO	Remote selected	0 - 1
6	RO	Local Stop selected	0 - 1
7	RO	Local selected	0 - 1
8	RO	Thermostat tripped	0 - 1
9	RO	Monitor relay	0 - 1
10	RO	Valve obstructed	0 - 1
11	RO	Valve jammed	0 - 1
12	RO	Valve moving by hand	0 - 1
13	RO	Moving inhibited by MIT	0 - 1
14	RO	Position control enabled	0 - 1
15	RO	EEPROM checksum failure	0 - 1
16	RO	Battery low	0 - 1
17	RO	Open interlock active	0 - 1
18	RO	Close interlock active	0 - 1
19	RO	DI-1	0 - 1
20	RO	DI-2	0 - 1
21	RO	DI-3	0 - 1
22	RO	DI-4	0 - 1
23	RO	Reserved	
24	RO	Reserved	
25	RO	Reserved	
26	RO	Control contention	0 - 1
27	RO	Partial stroke test in progress	0 - 1
28	RO	Partial stroke test error	0 - 1
29	RO	General alarm ①	0 - 1

Note: When the input is true the status reports as a '1'.

Note ① General alarm is any of the following: battery low/flat, valve alarm, actuator alarm, control alarm, valve jammed/obstructed, or monitor relay.

7. Modbus database *continued*

7.6.3 Data accessed with function code 03 – Read Holding Registers

The accessible registers that can be read with this function code also include the Input registers.

Location (Reg/Bit)		R/W	Data	Range
0	0	RO	Actuator moving	0 - 1
0	1	RO	Closed position limit	0 - 1
0	2	RO	Open position limit	0 - 1
0	3	RO	Running closed	0 - 1
0	4	RO	Running open	0 - 1
0	5	RO	Remote selected	0 - 1
0	6	RO	Local Stop selected (offline)	0 - 1
0	7	RO	Local selected	0 - 1
0	8	RO	Thermostat tripped	0 - 1
0	9	RO	Monitor relay	0 - 1
0	10	RO	Valve obstructed	0 - 1
0	11	RO	Valve jammed	0 - 1
0	12	RO	Valve moving by hand	0 - 1
0	13	RO	Moving inhibited by MIT	0 - 1
0	14	RO	Position control enabled	0 - 1
0	15	RO	EEPROM checksum failure	0 - 1
1	0	RO	Battery low	0 - 1
1	1	RO	Open interlock active	0 - 1
1	2	RO	Close interlock active	0 - 1
1	3	RO	DI-1	0 - 1
1	4	RO	DI-2	0 - 1
1	5	RO	DI-3	0 - 1
1	6	RO	DI-4	0 - 1
1	7	RO	Reserved	0
1	8	RO	Reserved	0
1	9	RO	Reserved	0
1	10	RO	Control contention	0 - 1
1	11	RO	Partial stroke test in progress	0 - 1
1	12	RO	Partial stroke test error	0 - 1
1	13	RO	General alarm*	0 - 1
1	14	RO	Reserved	0
1	15	RO	Reserved	0

7. Modbus database *continued*

Location (Reg/Bit)		R/W	Data	Range
2	-	RO	Actuator Instantaneous Torque	0 - 78 hex (0 - 120%)
3	-	RO	Valve Position	0 - 3E8 hex (0.0 - 100.0%)
4	-	RO	Analogue Input (IQ3 range set by Insight 2 only. Analogue signal type: 5,10, 20 V or mA)	0 - 3E8 hex (0.0 - 100.0%)
5	-	R/W	Actuator Digital Control	0 - 4 0 = stop 1 = close 2 = open 3 = ESD 4 = partial stroke test
6	-	R/W	Actuator Position DV (desired value)	0 - 3E8 hex (0.0 - 100.0%)
7-25	-	R/W	Actuator Parameters see Section 8	-
26-31	-	R/W	Actuator Tag name	12 bytes ASCII char

* General alarm is any of the following: battery low/flat, valve alarm, actuator alarm, control alarm, valve jammed/obstructed, or monitor relay.

7. Modbus database *continued*

The following data logger information is also accessed by function code 03. Torque values are in the range 0 – 120%. The registers are updated with new data a short period after the actuator stops moving, provided the actuator selector is in Remote. The registers may not contain the updated information for up to 2 minutes.

Location (Reg/Bit)		R/W	Data	Range
32	-	RO	Close Torque set	0-78 hex
33	-	RO	Open Torque set	0-78 hex
34	-	RO	Torque at 0% - open direction	0-78 hex
35	-	RO	Torque at 10% - open direction	0-78 hex
36	-	RO	Torque at 20% - open direction	0-78 hex
37	-	RO	Torque at 30% - open direction	0-78 hex
38	-	RO	Torque at 40% - open direction	0-78 hex
39	-	RO	Torque at 50% - open direction	0-78 hex
40	-	RO	Torque at 60% - open direction	0-78 hex
41	-	RO	Torque at 70% - open direction	0-78 hex
42	-	RO	Torque at 80% - open direction	0-78 hex
43	-	RO	Torque at 90% - open direction	0-78 hex
44	-	RO	Torque at 100% - open direction	0-78 hex
45	-	RO	Torque at 0% - close direction	0-78 hex
46	-	RO	Torque at 10% - close direction	0-78 hex
47	-	RO	Torque at 20% - close direction	0-78 hex
48	-	RO	Torque at 30% - close direction	0-78 hex
49	-	RO	Torque at 40% - close direction	0-78 hex
50	-	RO	Torque at 50% - close direction	0-78 hex
51	-	RO	Torque at 60% - close direction	0-78 hex
52	-	RO	Torque at 70% - close direction	0-78 hex
53	-	RO	Torque at 80% - close direction	0-78 hex
54	-	RO	Torque at 90% - close direction	0-78 hex
55	-	RO	Torque at 100% - close direction	0-78 hex
56	-	RO	Close Motor Starts low order	0-FFFF hex
57	-	RO	Close Motor Starts high order	0-FFFF hex
58	-	RO	Open Motor Starts low order	0-FFFF hex
59	-	RO	Open Motor Starts high order	0-FFFF hex
80	-	RO	Database format	0-1 hex

Note: For CVA; Registers 56 and 57 give contactor counts for open and close directions, Register 58 is total distance travelled and Register 59 is not used.

7. Modbus database *continued*

- ELB data in data logger register locations

ELB	R/W	Reg	Range 0-120%
N/A	R/O	32/-	0-78
N/A	R/O	33/-	0-78
Peak pressure at sensor1 in %	R/O	34/-	0-78
Peak pressure at sensor2 in %	R/O	35/-	0-78
Peak ROR in %	R/O	36/-	0-78
Peak ROD in %	R/O	37/-	0-78
Peak differential pressure in %	R/O	38/-	0-78
Peak cylinder pressure in %	R/O	39/-	0-78
Peak input voltage	R/O	40/-	0-78
Instantaneous pressure P2 in %	R/O	41/-	0-78
Instantaneous ROR in %	R/O	42/-	0-78
Instantaneous ROD in %	R/O	43/-	0-78

7.6.4 Data accessed with function code 04 – Read Input Registers

Location (Reg/Bit)		R/W	Data	Range
0	0	RO	Actuator moving	0-1
0	1	RO	Closed limit	0-1
0	2	RO	Open limit	0-1
0	3	RO	Running closed	0-1
0	4	RO	Running open	0-1
0	5	RO	Remote selected	0-1
0	6	RO	Local Stop selected	0-1
0	7	RO	Local selected	0-1
0	8	RO	Thermostat tripped	0-1
0	9	RO	Monitor relay	0-1
0	10	RO	Valve obstructed	0-1
0	11	RO	Valve jammed	0-1
0	12	RO	Valve moving by hand	0-1
0	13	RO	Moving inhibited	0-1
0	14	RO	Position control enabled	0-1
0	15	RO	EEPROM checksum failure	0-1
1	0	RO	Battery low	0-1
1	1	RO	Open interlock active	0-1
1	2	RO	Close interlock active	0-1
1	3	RO	DI-1	0-1

7. Modbus database *continued*

Location (Reg/Bit)		R/W	Data	Range
1	4	RO	DI-2	0-1
1	5	RO	DI-3	0-1
1	6	RO	DI-4	0-1
1	7	RO	Reserved	0-1
1	8	RO	Reserved	0
1	9	RO	Reserved	0
1	10	RO	Control contention	0-1
1	11	RO	Partial stroke test in progress	0-1
1	12	RO	Partial stroke test failed	0-1
1	13	RO	General alarm	0-1
1	14	RO	Reserved	0
1	15	RO	Reserved	0
2	-	RO	Actuator Instantaneous Torque	0 - 78 hex (0 - 120%)
3	-	RO	Valve Position	0 - 3E8 hex (0.0 - 100.0%)
4	-	RO	Analogue Input (IQ3 range set by Insight 2 only. Analogue signal type: 5,10, 20 V or mA)	0 - 3E8 hex (0.0 - 100.0%)

7.6.5 Data accessed with function code 05 and 15 – Force Single and Multiple Coils

Location Bit)	R/W	Data	Range
0	R/W	Stop command output coil status	0-FF00 hex
1	R/W	Close command output coil status	0-FF00 hex
2	R/W	Open command output coil status	0-FF00 hex
3	R/W	ESD command output coil status	0-FF00 hex
4	R/W	DO-1 output coil status (extra relay S5)	0-FF00 hex
5	R/W	DO-2 output coil status (extra relay S6)	0-FF00 hex
6	R/W	DO-3 output coil status (extra relay S7)	0-FF00 hex
7	R/W	DO-4 output coil status (extra relay S8)	0-FF00 hex
8	R/W	Partial stroke test	0-FF00 hex

Using code 05 write FF00 (hex) to turn on the command, DO-1 to DO-4 are turned off by writing '0'. The other coil commands are cleared by various means as explained in Section 5.1.2.

Using code 15 write 1 to turn on the command and 0 to turn off the command.

The commands to open, close, stop, ESD or partial stroke test the actuator are not cancelled by writing a '0', but this will de-energise the coils. The actuator latches the instruction and will complete the action unless a subsequent counter command is received before the action is completed.

7. Modbus database *continued*

7.6.6 Data accessed with function code 06 and 16 – Preset Single and Multiple Registers

Location (Reg/Bit)		R/W	Data	Range
5	-	R/W	Actuator Digital Control	0-4 0 = stop 1 = close 2 = open 3 = ESD 4 = partial stroke test ①
6	-	R/W	Actuator Position DV (desired value)	0 - 3E8 hex (0.0 - 100.0%)

Note ① Integer value, not bit location.

The Actuator Digital Control register allows one of the five commands to be selected by writing the appropriate value.

Provided limited range positioning is not invoked, the Actuator Position DV register assigns a special importance to the values 0% and 100% written to this register. The command is revised to fully close the valve to its tight shut off position (0%) and to fully open the valve (100%).

7.6.7 Data accessed with function code 07 – Read Exception Status

Code 07 reads a predefined data set with minimal overheads and is used for fast data transfer. A single byte is returned.

Location Bit	R/W	Data	Range
0	RO	ESD coil status	0-1
1	RO	Open coil status	0-1
2	RO	Close coil status	0-1
3	RO	Stop coil status	0-1
4	RO	Closed position limit	0-1
5	RO	Open position limit	0-1
6	RO	Monitor relay	0-1
7	RO	Reserved	0-1

7.6.8 Data accessed with function code 08 – Loopback Diagnostic Test

The Loopback Test is used to test communications only. In a correctly working unit the return message is the same as the query sent. Two codes are supported.

Code	Data
00	Return query data
02	Return diagnostic register

The Diagnostic Register contains the following data.

Location (Reg/Bit)		R/W	Data	Range
-	0	RO	Memory status fault	0-1
-	1	RO	Auxiliary control input active	0-1
-	2	RO	Position controller enabled	0-1
-	3	RO	Highway ESD active	0-1

7. Modbus database *continued*

7.6.9 Data accessed with function code 17 – Report Slave ID

The Slave ID data response includes 30 registers, (60 bytes) of ASCII data to give the device name, software version and service tag number.

Byte	Data
1 - 23	'Null Null Rotork MODBUS MODULE.'
24 - 28	Software version: 'xxx' (where xxx is the revision number)
29 - 60	Tag Name 12 bytes, plus 20 spaces (for IQ3)

7.6.10 ELB only – Alarm table

The registers 45,46 and 47 are allocated for alarms and they are read as a whole using the read holding register function '03'. The user shall then bit-access these 3 registers in the Modbus interfacing application for individual alarms.

ELB	Modbus Side			
	Access	Reg/Bit	Function codes	Value/range (hex)
Hardware error	R/O	47/0	03	0 - FF
Pressure P1 out of range	R/O	47/1	03	0 - FF
Pressure P2 out of range	R/O	47/2	03	0 - FF
Position out of range	R/O	47/3	03	0 - FF
System voltage fault	R/O	47/4	03	0 - FF
UIB Comms Loss	R/O	47/5	03	0 - FF
Local remote fault	R/O	47/6	03	0 - FF
External ADC fail	R/O	47/7	03	0 - FF
High pressure alarm	R/O	48/0	03	0 - FF
Low pressure alarm	R/O	48/1	03	0 - FF
ROR alarm	R/O	48/2	03	0 - FF
ROD alarm	R/O	48/3	03	0 - FF
High differential alarm	R/O	48/4	03	0 - FF
N/A	R/O	48/5	03	0 - FF
Transmitter out of sync alarm	R/O	48/6	03	0 - FF
Input voltage high alarm	R/O	48/7	03	0 - FF
Input voltage low alarm	R/O	49/0	03	0 - FF
Cylinder pressure OPEN alarm	R/O	49/1	03	0 - FF
High temperature TRIP	R/O	49/2	03	0 - FF
Low temperature TRIP	R/O	49/3	03	0 - FF
Configuration error	R/O	49/4	03	0 - FF
Cylinder pressure out of range	R/O	49/5	03	0 - FF
Cylinder pressure CLOSE alarm	R/O	49/6	03	0 - FF
N/A	R/O	49/7	03	0 - FF
Instantaneous differential pressure in %	R/O	44/-	03	0 - FF
Instantaneous cylinder pressure in %	R/O	45/-	03	0 - FF
Instantaneous input voltage	R/O	46/-	03	0 - FF

7. Modbus database *continued*

ELB	Modbus Side			
	Access	Reg/Bit	Function codes	Value/range (hex)
Alarms - I	R/O	47/-	03	0 - FF
Alarms - II	R/O	48/-	03	0 - FF
Alarms - III	R/O	49/-	03	0 - FF
N/A	R/O	50/-	03	0 - FF
Alerts - I	R/O	51/-	03	0 - FF
Alerts - II	R/O	52/-	03	0 - FF
N/A	R/O	53/-	03	0 - FF
N/A	R/O	54/-	03	0 - FF
N/A	R/O	55/-	03	0 - FF
N/A	R/O	56-57	03	0 - FF
N/A	R/O	58-59	03	0 - FF

7.6.11 ELB only – Alerts table

The registers 51 and 52 are allocated for alerts and they are read as a whole using the read holding register function '03'. The user shall then bit-access these 2 registers in the Modbus interfacing application for individual alerts.

ELB	Modbus Side			
	Access	Reg/Bit	Function codes	Value/range (hex)
High pressure alert	R/O	51/0	03	0 - FF
Low pressure alert	R/O	51/1	03	0 - FF
ROR alert	R/O	51/2	03	0 - FF
ROD alert	R/O	51/3	03	0 - FF
High differential alert	R/O	51/4	03	0 - FF
N/A	R/O	51/5	03	0 - FF
N/A	R/O	51/6	03	0 - FF
Input voltage high alert	R/O	51/7	03	0 - FF
Input voltage low alert	R/O	52/0	03	0 - FF
N/A	R/O	52/1	03	0 - FF
N/A	R/O	52/2	03	0 - FF
N/A	R/O	52/3	03	0 - FF
N/A	R/O	52/4	03	0 - FF
N/A	R/O	52/5	03	0 - FF
N/A	R/O	52/6	03	0 - FF
N/A	R/O	52/7	03	0 - FF

7. Modbus database *continued*

7.7 Database summary

Data	ELB	IQ3	SI3/ SI4	CVA	CMA	K-range	Location (Register/ Bit)	Function	Accessed by Modbus function code							
									01	02	03	04	05	06	07	15
Stop	✓	✓	✓	✓	✓	✓	Coil 0	Digital Output	01				05		07	15
Close	✓	✓	✓	✓	✓	✓	Coil 1	Digital Output	01				05		07	15
Open	✓	✓	✓	✓	✓	✓	Coil 2	Digital Output	01				05		07	15
ESD	✓	✓	✓	✓	✓	✓	Coil 3	Digital Output	01				05		07	15
Output DO-1 (extra relay S5)①	✗	✓	✓	✗	✓	✗	Coil 4	Digital Output	01				05			15
Output DO-2 (extra relay S6)①	✗	✓	✓	✗	✓	✗	Coil 5	Digital Output	01				05			15
Output DO-3 (extra relay S7)①	✓	✓	✓	✗	✓	✗	Coil 6	Digital Output	01				05			15
Output DO-4 (extra relay S8)①	✗	✓	✓	✗	✓	✗	Coil 7	Digital Output	01				05			15
Partial Stroke	✓	✓	✓	✓	✗	✓	Coil 8	Digital Output	01				05			15
Output DO-5 (Actuator Relay S1 IQ3 only)②	✗	✓	✗	✗	✗	✗	Coil 9	Digital Output	01				05			15
Output DO-6 (Actuator Relay S2 IQ3 only)②	✗	✓	✗	✗	✗	✗	Coil 10	Digital Output	01				05			15
Output DO-7 (Actuator Relay S3 IQ3 only)②	✗	✓	✗	✗	✗	✗	Coil 11	Digital Output	01				05			15
Output DO-8 (Actuator Relay S4 IQ3 only)②	✗	✓	✗	✗	✗	✗	Coil 12	Digital Output	01				05			15
Actuator Moving	✓	✓	✓	✓	✓	✓	0/0	Digital Input		02	03	04				
Close position limit	✓	✓	✓	✓	✓	✓	0/1	Digital Input		02	03	04			07	
Open position limit	✓	✓	✓	✓	✓	✓	0/2	Digital Input		02	03	04			07	
Valve running closed	✓	✓	✓	✓	✓	✓	0/3	Digital Input		02	03	04				
Valve running open	✓	✓	✓	✓	✓	✓	0/4	Digital Input		02	03	04				
Selector in Remote	✓	✓	✓	RUN	✓	✓	0/5	Digital Input		02	03	04				
Selector in Local Stop	✓	✓	✓	STOP	✓	✓	0/6	Digital Input		02	03	04				
Selector in Local	✓	✓	✓	③	✓	✓	0/7	Digital Input		02	03	04				
Thermostat tripped	④	✓	✓	✓	✓	✓	0/8	Digital Input		02	03	04				
Monitor relay	✓	✓	✓	✓	✓	✓	0/9	Digital Input		02	03	04			07	
Valve obstructed	⑤	✓	✓	✓	✓	✓	0/10	Digital Input		02	03	04				
Valve jammed	⑥	✓	✓	✓	✓	✓	0/11	Digital Input		02	03	04				
Manual movement	⑦	✓	✓	✓	✗	✓	0/12	Digital Input		02	03	04				
MIT/Interrupter timer	⑧	✓	✓	✗	✗	✓	0/13	Digital Input		02	03	04				
Position control enabled	✗	✓	✓	✗	✓	✓	0/14	Digital Input		02	03	04				
Watchdog Recovery	✗	✓	✓	✗	✗	✗	0/15	Digital Input		02	03	04				
Battery Low	✗	✓	✗	④	✗	✗	1/0	Digital Input		02	03	04				
Open interlock input active	✗	✓	✗	✗	✗	✓	1/1	Digital Input		02	03	04				
Close interlock input active	✗	✓	✗	✗	✗	✓	1/2	Digital Input		02	03	04				
Hardwired input DI-1 (open)	✗	✓	✓	✗	✗	✓	1/3	Digital Input		02	03	04				
Hardwired input DI-2 (close)	✗	✓	✓	⑤	✗	✓	1/4	Digital Input		02	03	04				
Hardwired input DI-3 (stop)	✗	✓	✓	✗	✗	✓	1/5	Digital Input		02	03	04				
Hardwired input DI-4 (ESD)	✗	✓	✓	✗	✗	✓	1/6	Digital Input		02	03	04				
Reserved	✗	✗	✗	✗	✗	✗	1/7	Digital Input								
Reserved	✗	✗	✗	✗	✗	✗	1/8	Digital Input								
Reserved	✗	✗	✗	✗	✗	✗	1/9	Digital Input								

7. Modbus database *continued*

Data	ELB	IQ3	SI3/ SI4	CVA	CMA	K-range	Location (Register/ Bit)	Function	Accessed by Modbus function code								
									01	02	03	04	05	06	07	15	16
Control contention	⑬	✓	✓	✓	✓	✓	1/10	Digital Input		02	03	04					
Partial stroke test in progress	✓	✓	✓	✗	✗	✗	1/11	Digital Input		02	03	04					
Partial stroke test error	✓	✓	✓	✗	✗	✗	1/12	Digital Input		02	03	04					
General alarm	✗	✓	✓	✓	✓	✓	1/13	Digital Input		02	03	04					
Reserved	✗	✗	✗	✗	✗	✗	1/14	Digital Input									
Reserved	✗	✗	✗	✗	✗	✗	1/15	Digital Input									
Instantaneous torque	⑭	✓	⑥	⑦	✓	✓	2/-	Input register			03	04					
Valve position	✓	✓	✓	✓	✓	✓	3/-	Input register			03	04					
Analogue input	✗	✓	✗	✓	✓	✓	4/-	Input register			03	04					
Actuator digital control	✓	✓	✓	✓	✓	✓	5/-	Output register			03		06				16
Position demand output	✗	✓	✓	✓	✓	✓	6/-	Output register			03		06				16
Action on loss of signal	✗	✓	✓	✓	✓	✓	7/-	Parameter register			03		06				16
Min position	✗	✓	✗	✓	✓	✓	8/-	Parameter register			03		06				16
Max position	✗	✓	✗	✓	✓	✓	9/-	Parameter register			03		06				16
Deadband	✗	✓	✗	✓	✓	✓	10/-	Parameter register			03		06				16
Motion Inhibit timer MIT	✗	✓	✗	✓	✗	✓	11/-	Parameter register			03		06				16
Auxiliary input mask	✗	✓	✓	✓	✓	✓	12/-	Parameter register			03		06				16
Communications lost position	✗	✓	✓	✓	✓	✓	13/-	Parameter register			03		06				16
Hysteresis	✗	✓	✗	✓	✓	✓	14/-	Parameter register			03		06				16
Slow mode range	✗	✗	✗	✓	✗	✗	15/-	Parameter register			03		06				16
Valve jammed time	✗	✗	✗	✓	✗	✓	16/-	Parameter register			03		06				16
Manual movement travel	✗	✗	✗	✓	✗	✓	17/-	Parameter register			03		06				16
Reserved	✗	✗	✗	✗	✗	✗	18/-	Parameter register									
ESD DI-4/Net disable	✗	✓	✗	✓	✓	✓	19/-	Parameter register			03		06				16
Analogue input max	✗	✓	✗	✓	✓	✓	20/-	Parameter register			03		06				16
Communications Fault timer	✗	✓	✓	✓	✓	✓	21/-	Parameter register			03		06				16
Address	✗	✓	✓	✓	✓	✓	22/-	Parameter register			03		06				16
Baud rate	✓	✓	✓	✓	✓	✓	23/-	Parameter register			03		06				16
Parity, stop bits	✓	✓	✓	✓	✓	✓	24/-	Parameter register			03		06				16
Termination on=1, off=0	✓	✓	✓	✓	✓	✓	25/-	Parameter register			03		06				16
Actuator tag number	✓	✓	✓	✓	✓	✓	26-31/-	Parameter register			03		06				16
Data logger data	⑮	✓	✓	✓	✓	✓	32-59/-	Input register			03						

Note ① DIO1 (IQ3) or RIR01 (CVA) or Extra Relay board 1 must be fitted.
 Note ② DIO2 (IQ3) or RIR02 (CVA) or Extra Relay board 2 must be fitted.
 Note ③ Manual control using Enlight (See www.rotork.com).
 Note ④ UPS Fault.
 Note ⑤ UPS in use.
 Note ⑥ Pressure.
 Note ⑦ Torque on CVA, Thrust on CVL.
 Note ⑧ Manual Reset Required.
 Note ⑨ Valve Stalled.
 Note ⑩ ESD Active.
 Note ⑪ System Alarm.
 Note ⑫ Instantaneous Pressure P1 in %.
 Note ⑬ Partial Stroke Limit.
 Note ⑭ System Alert.
 Note ⑮ See ELB data in Sections 7.6.3, 7.6.10 and 7.6.11.

7. Modbus database *continued*

7.8 Configuration registers

In order to make the best use of the MFU, the module has a number of configurable parameter registers that may be adjusted to optimise the performance of the actuator. All the parameter registers have factory default settings designed to meet the most common requirements for the actuator. If these are not suitable for a particular application, then the values can be changed by using a Modbus communication tool.

The Modbus Module contains 20 configurable parameter registers and some can be altered by using the infra-red or Bluetooth communications link and the setting tool. By using a Modbus communication tool connected to the RS-485 highway all the registers may be reviewed and altered to suit the particular application for the actuator.

Care must be exercised with access to these parameter registers as they can alter the complete performance of the actuator.

This section of the manual describes each variable parameter register and should be used for reference when using the configuration tools. All the registers can be read using function code 03 (Read Holding Registers). The contained values may be altered using function code 06 (Preset Single Register) or function code 16 (Preset Multiple Registers).

- Actuator related network configurable parameter registers

Description	Value/range	Default value	Location (register)	R/W access		
Action on Loss of Comms	0 = Nothing (No Action) 1 = Open 3 = Close 5 = Stop 7 = Position Any other value = Off	0 = Nothing (0000 hex)	7	03	06	16
Limited Range Position Minimum	0 – 100% 0000 – 0064 hex	0% 0000	8	03	06	16
Limited Range Position Maximum	0 – 100% 0000 – 0064 hex	100% 0064 hex	9	03	06	16
Deadband ①	– 25.5% 0000 – 00FF hex	5.0% 0032 hex	10	03	06	16
Motion Inhibit Time	0 – 255 sec 0000 – 00FF hex	5 sec 0005 hex	11	03	06	16
Aux Input Mask	0 – 255 0000 – 00FF hex	15 000F hex	12	03	06	16
Comms Lost Position	0 – 100% 0000 – 0064 hex	0% 0000 hex	13	03	06	16
Hysteresis ①	0 – 25.5% 0000 – 00FF hex	2.0% 0014 hex	14	03	06	16
Slow Mode Range	0 – 100% 0000 – 0064 hex	5% 0005 hex	15	03	06	16
Valve Jammed Time	0 – 255 sec 0000 – 00FF hex	5 sec 0005 hex	16	03	06	16
Manual Movement Travel	0 – 100% 0000 – 0064 hex	10% 000A hex	17	03	06	16
Watchdog Timeout	0 – 255 sec 0000 – 00FF hex	10 sec 000A hex	18	03	06	16
ESD DI-4/Net Disable	DI-4 is ESD = 0 DI-4 is Net Disable = 1	ESD 0000 hex	19	03	06	16
Analogue Input Max/Min	1 – 2 0001 – 0002 hex	0 0000 hex	20	03	06	16
Comms Fault Timer	0 – 255 sec 0000 – 00FF hex	10 sec 000A hex	21	03	06	16

Note: ① - Setting the deadband lower than the hysteresis or the hysteresis greater than the deadband causes the hysteresis to be set to 0.1%

7. Modbus database *continued*

- Modbus network related network configurable parameter registers

Description	Value/range	Default value	Location (register)	R/W Access		
Modbus Address	1 – 247 0001 – 00F7 hex	247 00F7 hex	22	03	06	16
Baud Rate (baud)	0 = not used 1 = 300 6 = 9k6 2 = 600 7 = 19k2 3 = 1k2 8 = 38k4 4 = 2k4 9 = 57k6 5 = 4k8 10 = 115k2 0001 – 000A hex	9k6 (0006 hex)	23	03	06	16
Parity/Stop bits	0 = No parity, 1 stop bit 1 = No parity, 2 stop bits 2 = Even, 1 stop bit 3 = Even, 2 stop bits 4 = Odd, 1 stop bit 5 = Odd, 2 stop bits	None/1 stop (0000 hex)	24	03	06	16
Network Termination	0 = Off, 1 = On	0 (0000 hex)	25	03	06	16
Actuator Tag Name	Any ASCII character (12 characters max)	(blank) all = 0000	26 to 31	03	06	16
Database format	0 = Rotork 1 = Custom	0	80	03	06	

7. Modbus database *continued*

7.9 Actuator related configurable parameter registers

These parameter registers set up the response that the actuator will make to various control and network actions.

7.9.1 Action on Loss of Comms (Register 7)

This register is used with Register 13 (Comms Lost Position) and 21 (Comms Fault Timer).

The Action on Loss of Comms register specifies the actuator action that will result after the time set for the Comms Fault Timer (Register 21) if there is no network communication activity detected by the MFU.

The action may be:

- Nothing (0) No action; the actuator will complete any command in process (default setting)
- Open (1) The actuator will open the valve
- Close (3) The actuator will close the valve
- Stop (5) The actuator stops
- Position (7) The actuator will move the valve to the position set in the Comms Lost Position (Register 13).

7.9.2 Limited range position minimum and maximum (Registers 8 and 9)

These parameter registers are used to define the positions in the range of valve travel that will be reported as 0 to 100% if it the whole travel from the closed position to the open position is not used. In addition, the position demand setpoint output value will also be modified to follow this limited range.

It is possible to make the position data reported and the position controller relate to a reduced span of actual valve travel. In this mode the position data relates to the reduced portion of the valve stroke. This is sometimes used where the valve is required to have a 0% position (or 100% position) that is not the same as the fully closed position (or fully open position). These parameters define the actual limited range of valve travel that will be used for the position reporting and control by the positioner.

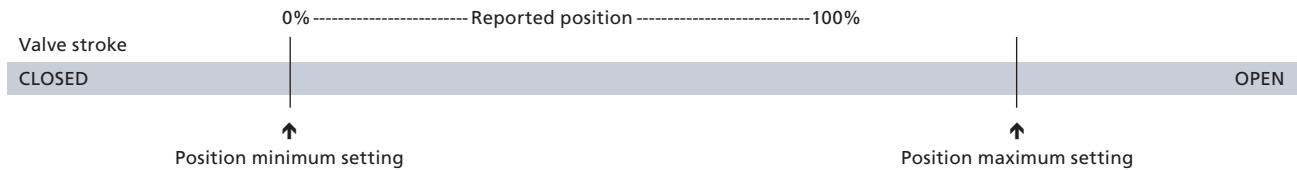

Fig 18: Limited range position control and reporting

Note that the digital open and close commands will still make the valve travel over its full stroke. The special case analogue commands of 0% and 100% that would otherwise cause the actuator to travel to the limit switch or torque off positions are inhibited if values other than 0 and 100 are set in these parameters.

The values inserted relate to the maximum total valve travel between closed and open and represent the point in the full stroke which will now be used for the limited stroke 0 and 100 values.

7. Modbus database *continued*

7.9.3 Deadband and hysteresis (Registers 10 and 14)

When using position control by sending a value to the Actuator Position DV setpoint there are a number of parameter registers used to tune the position controller and reduce the possibility of damage to the actuator. These two registers are set to prevent hunting around the setpoint due to high inertia of the valve. They will require adjustment for each specific application. In addition, the Motion Inhibit Timer is used to ensure the actuator does not carry out an excessive number of starts in a given period.

- **Deadband**

The control used for the positioner is proportional only. The MFU will run the actuator to the desired position and then it stops. As the actuator and valve combination have some inertia there is a possibility that the desired position may be overrun and the positioner will then reverse the direction of travel to make the valve adopt the desired position. This overshoot and return may continue for a number of cycles and is known as hunting; the valve and actuator combination will hunt around the setpoint if the inertia is high and the deadband is set too low. To prevent this from happening there is a Deadband setting whereby once the actuator enters the deadband the motor will be stopped. For example a 5% deadband will cause the motor to be stopped once the actual position is within 5% of the desired position. The inertia will then bring the actual position nearer the desired position.

The deadband is the allowable error around the setpoint. This determines the minimum step change response of the actuator.
- **Hysteresis**

In addition to the deadband a second setting, hysteresis, further refines the performance of the position controller. The positioner will run the actuator towards the setpoint DV until the actual position is within the deadband minus the hysteresis setting. This has the effect of instructing the actuator to stop when it is nearer the DV. The actuator will not restart unless it overshoots and runs outside the deadband or a new command places the new desired position outside the deadband.

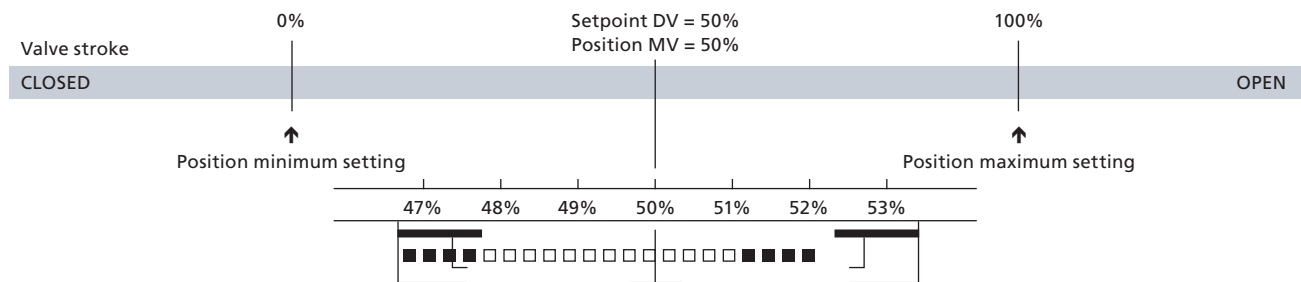

Fig 19: Deadband and hysteresis settings

The hysteresis is the amount of movement inside the deadband permitted before the motor stops.

7.9.4 Motion Inhibit Timer (MIT) (Register 11)

The MIT setting is the period that must elapse between consecutive starts of the actuator motor when in positioning mode. The time runs from when the motor stops until the next time it starts.

The idle period will prevent the actuator motor from exceeding its rated number of starts per hour.

In addition, when tuning the valve positioner, the setting can be used to allow the plant dynamics to stabilise between valve movements.

7. Modbus database *continued*

7.9.5 Auxiliary Input Mask (Register 12)

This parameter register allows the auxiliary inputs (open, stop, close, ESD) to be set to control the actuator or simply to report their status. In addition, it allows the sense of the input (open or closed contact) that is reported as true (1) to be set. Actuator control always requires a true (1) input signal. The status of the inputs is always reported over the network and they can be used to report associated plant inputs instead of controlling the actuator.

The register should be considered in its binary format using the low order byte. The number has the binary form $x_7x_6x_5x_4, y_3y_2y_1y_0$, requiring 8 bits. Each bit in the high order nibble, $x_7x_6x_5x_4$, either enables or disables the associated input for control of the actuator. The bits in the low order nibble, $y_3y_2y_1y_0$, determine if the input reports a closed contact as a '1' or an open contact as a '1'. Only when the input is a '1', as set by the mask, and the contact state is normally open will the actuator respond to the input if it is also set to control the actuator.

To allow an input to act as a control signal, its associated bit in the high order nibble must be set to a '1' in the mask. To allow a closed contact to be reported as a '1' then its associated bit in the low order nibble must be set to '1' in the mask.

Bit	Position	Value	Function
7	X^7	0	Disable ESD input as command
		1	Enable ESD input as command
6	X^6	0	Disable Stop/Maintain input as command
		1	Enable Stop/Maintain input as command
5	X^5	0	Disable Close input as command
		1	Enable Close input as command
4	X^4	0	Disable Open input as command
		1	Enable Open input as command
3	Y^3	0	Report closed contact on ESD input as '0'
		1	Report closed contact on ESD input as '1'
2	Y^2	0	Report closed contact on Stop/Maintain input as '0'
		1	Report closed contact on Stop/Maintain input as '1'
1	Y^1	0	Report closed contact on Close input as '0'
		1	Report closed contact on Close input as '1'
0	Y^0	0	Report closed contact on Open input as '0'
		1	Report closed contact on Open input as '1'

The following examples show how the Auxiliary Input Mask settings can be applied.

	Most significant Bit				Least significant Bit			
	Bit 7	Bit 6	Bit 5	Bit 4	Bit 3	Bit 2	Bit 1	Bit 0
	X^7	X^6	X^5	X^4	Y^3	Y^2	Y^1	Y^0
	Enable DI-4 ESD	Enable DI-3 Stop	Enable DI-2 Close	Enable DI-1 Open	Invert DI-4	Invert DI-3	Invert DI-2	Invert DI-1
Example 1	0	0	0	0	1	1	1	1
Example 2	1	1	1	1	1	1	1	1
Example 3	0	0	0	0	0	0	0	0

7. Modbus database *continued*

- **Example 1** The default value of '15' (0000, 1111 binary or 0F hex) makes all 4 inputs report closed contacts as true (1) and none of the inputs will operate the actuator.
- **Example 2** The value 255 (1111,1111 binary or FF hex) makes all 4 inputs report closed contacts as true (1) and all the inputs control the actuator in their predefined way.
- **Example 3** The value 0 (0000, 0000 binary or 00 hex) makes all 4 inputs report open contacts as true (1) and none of the inputs will operate the actuator.

7.9.6 Comms Lost Position (Register 13)

The setting in this parameter register determines the position in the range 0 to 100% that the actuator will move to if the Modbus network communications stops being received, provided the Fault Mode (Register 1) is set to 'Position'. No action will be taken unless the communications stops for a period equal or greater than the setting in the Comms Fault Timer (Register 21).

7.9.7 ESD DI-4/Net Disable (Register 19)

In the IQ3 actuator this input determines the mode of operation for the ESD/DI-4 remote input. The input can be used either to disable control of the actuator from the network, or to act as an ESD/digital input. When this setting is made 'Active' the input will disable network control of the actuator when the contact input is closed, irrespective of the Aux Mask setting.

7.9.8 Analogue Input Max/Min (Register 20)

This parameter register is used when the IQ3 actuator has a Modbus card and an Analogue Input card fitted. To calibrate the Analogue card, its maximum input is applied and a value of 1 is written to Parameter 20. Then the minimum analogue input is applied and a value of 2 is written to Parameter 20. Once this is done, the Analogue card will scale the input from 0 to 1000. The input range must be set using Insight2, to select voltage or current.

7.9.9 Comms Fault Timer (Register 21)

Parameter Register 21, the Comms Fault Timer setting, determines the number of seconds that network communication must be absent before the setting for the Fault Mode will be carried out. The values range from 0 to 65 seconds.

7. Modbus database *continued*

7.10 Modbus network related configurable parameter registers

These parameter registers set up the MFU for network communications.

7.10.1 Modbus Address (Register 22)

The Modbus Address is the address on the network that the Modbus module will respond to. The address can be in the range 1 to 247, though 247 is generally not used, as this is the default address and may be used by any newly introduced device on the network.

With a dual channel unit, both channels can use the same address or different addresses.

7.10.2 Baud Rate (Register 23)

Register 23 sets the communication baud rate. On a dual channel unit both channels operate at the same baud rate.

7.10.3 Parity and Stop Bits (Register 24)

The parity and number of stop bits used in the communications is selected by altering the content of this register. On a dual channel unit both channels operate using the same parity and stop bit setting.

7.10.4 Termination (Register 25)

This parameter register is used to switch the network termination on within the MFU. This should only be done where the actuator is the last device on a network segment. See Section 4.4.

7.10.5 Actuator Tag Name (Register 26 to 31)

The MFU may be programmed to contain a 12 character tag name string in these registers. Each byte contains one character.

7.10.6 Database format (Register 80)

This parameter is used to set up the MFU database, for the products covered by this manual it should be left at the default value (0), selecting the Rotork database.

8. Setting up and maintaining the MFU

In most applications, most of the default settings in the Modbus module will be suitable for operation of the valve and need not be altered. However, in every case it will be necessary to alter the address since the default should never be used within a live system (the default value is 247).

8.1 Using a network configuration tool

Any device capable of writing register values can be used to configure the Modbus module. Changes to the actuator-related parameter registers and network related parameter registers become active immediately they are altered.

The individual register values required may be different for each actuator and will depend on the application and process being controlled as well as the actuator size, speed and other design features.

8.2 Setting up an IQ3 with the setting tool

The IQ3 actuator includes an infra-red and a Bluetooth communication port for setting the actuator performance, limit switches and so on. This communication link can be used to set some, but not all, of the MFU parameter registers. The registers should still be checked with a Modbus host device to ensure optimum actuator and network compatibility.

The parameters that may be set by using the setting tool and the infra-red or Bluetooth link are listed below. The available range for the deadband setting when using the setting tool is less than the range found using the configuration tools.

Parameters may only be altered if the actuator control knob is set to the Local or Local Stop position.

Register number	Description	Range	Default value
7	Action on Loss of Comms	Nothing (No Action), Stop, Close, Open, Position	Nothing
8	Limited Range Position Minimum	0 - 100%	0%
9	Limited Range Position Maximum	0 - 100%	100%
10	Deadband	0.0 - 25.5%	5.0%
11	Motion Inhibit Time	0 - 255 sec	3 sec
12	Aux Input Mask	0 - 255 (00 – FF hex)	15 (0F)
13	Comms Lost Position	0.0 - 100.0%	0.0%
14	Hysteresis	0.0 - 25.5%	2.0%
22	Address	0 - 247	247
23	Baud Rate (baud)	300, 600, 1k2, 2k4, 4k8, 9k6, 19k2, 38k4, 57k6 and 115k2	9k6
24	Parity (1 stop bit)	Odd, Even, None	None
25	Termination	0 = Off – 1 = On	Off
80	Database format	0 = Rotork – 1 = Custom	Rotork

8.3 Maintenance and repair

There is no periodic service requirement for the MFU.

Repairs should not be attempted on the module. Replacing the MFU assembly with a new replacement device should rectify any failure. Static sensitive devices are used in the MFU. It is therefore mandatory to observe anti-static precautions when handling or working on the unit.

8. Setting up and maintaining the MFU *continued*

8.4 Records

If a device failure occurs and a replacement is required, it is important have a record of settings for the variable registers. Record and keep safe all the settings made for the variable registers using the below tables. The tables include all the registers that must be checked and set up for each Modbus module on a network. The data should be recorded for each module.

Note: Make a note of all changes to the register settings to ensure that, in the case of a failure, the replacement device can be swiftly set to the correct values.

- **Actuator configurable registers**

Parameter Number	Description	Setting	Notes
7	Action on Loss of Comms		
8	Limited Range Position Minimum		
9	Limited Range Position Maximum		
10	Deadband		
11	Motion Inhibit Time		
12	Aux Input Mask		
13	Comms Lost Position		
14	Hysteresis		
19	ESD DI-4/Net Disable		
21	Comms Fault Timer		

- **Network configurable registers**

Parameter number	Description	Setting	Notes
22	Address		
23	Baud Rate (baud)		
24	Parity and Stop bits		
25	Termination on or off		
26-31	Actuator Tag Name		
80	Database format		

8. Setting up and maintaining the MFU *continued*

8.4.1 Troubleshooting

In general, most of the problems that are seen with actuators fitted to a Modbus network are due to wiring errors and are simple to test and fix.

Often, the problem is that the network is connected to the wrong actuator terminals. The correct terminal numbers are given in the wiring diagram that comes with each new actuator. If this diagram has been lost, then a new one can be found on the Rotork web site. The wiring diagram number is usually given on the actuator name plate.

The terminal connections can be confirmed with a multimeter. With the actuator powered-down, a resistance of approximately 73,000 ohms should be measured across the correct terminals. This will also confirm that the actuator internal loom is correctly connected to a working MFU.

If the reading is open circuit, then there may be a loom problem (only to be seen in a retrofitted actuator – all actuators are factory tested before shipping), there may not be an MFU fitted, or the MFU may be damaged.

If the network is attached to the correct terminals and there are no communications, then perhaps the A and B connections are reversed. These could be swapped, again with the actuator powered down, and communications checked again with the actuator powered up.

If there are still issues with communications, then please confirm that the correct address, baud rate and parity have been set in the actuator and that they correspond with the settings in the known working DCS.

If there are still issues with communications, please contact Rotork technical support at the telephone numbers given on the back page of this manual.

The following information helps with the investigation:

1. Actuator serial number from the actuator name plate.
2. Wiring diagram number from the actuator name plate.
3. Software version. If the actuator has a display, the software versions of the fitted PCBs may be obtained by following the instructions in the actuator manual. If there is no software version given for the MFU, then it may not be fitted. If the actuator has no display and no communications, you will not be able to obtain the software version of the MFU.
4. Type of actuator.
5. Feedback from DCS.

rotork®



www.rotork.com

A full listing of our worldwide sales and service network is available on our website.

Rotork plc
Brassmill Lane, Bath, UK
tel +44 (0)1225 733200
email mail@rotork.com

PUB091-004-00
Issue 07/24

As part of a process of on-going product development, Rotork reserves the right to amend and change specifications without prior notice. Published data may be subject to change. For the very latest version release, visit our website at www.rotork.com

The name Rotork is a registered trademark. Rotork recognises all registered trademarks. Published and produced in the UK by Rotork. POLTG0724