

rotork

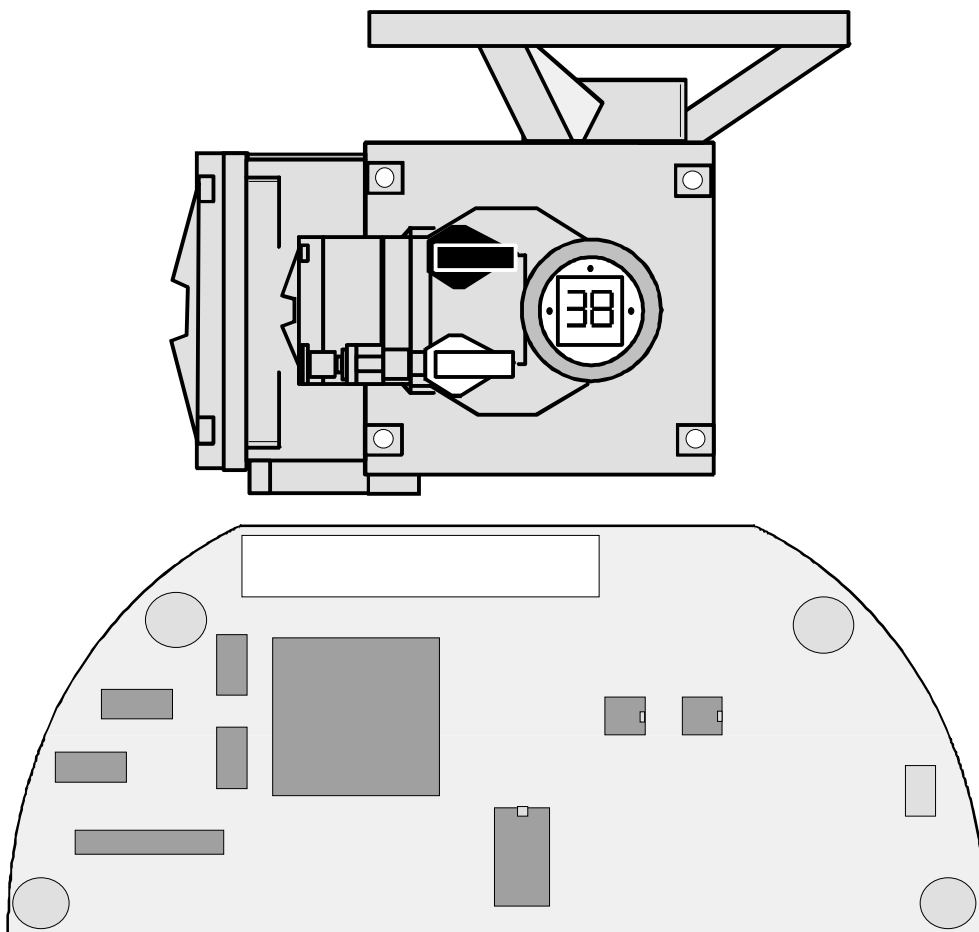

IQ Modbus Module Technical Manual

As we are continually developing our products their design is subject to change without notice.

© The contents of this document are copyright and must not be reproduced without the written permission of Rotork Controls Ltd.

Modbus is a registered trade mark of Modicon

Contents:

- 1 Introduction**
- 2 Module Properties**
 - 2.1 Mechanical Properties
 - 2.2 Electrical Properties
 - 2.3 Operation and Storage
- 3 Fitting the Modbus Module**
 - 3.1 Replacing or Fitting a Module
 - 3.2 Remote Input Board
 - 3.3 Fitting a Remote Input Board
 - 3.4 Dual Redundancy
- 4 RS485 2/4 Wire Connections**
- 5 Modbus Module Configurations**
 - 5.1 Basic Module, (200-500)
 - 5.2 Module + Remote Board, (200-400)
 - 5.3 Module + Remote Board + Data Logger, (200-410)
- 6 Input and Output Signals**
 - 6.1 Digital Inputs
 - 6.2 Digital Outputs
 - 6.3 Input Registers
 - 6.4 Output Registers
 - 6.5 Additional Data
- 7 Modbus support**
 - 7.1 Modbus Specification
 - 7.2 Modbus Function Code Support
- 8 Setting Up a Modbus Module**
 - 8.1 Using an IQ setting Tool
 - 8.2 Using an IQ Communicator
- 9 Programming a Modbus Module**
- 10 Maintenance and Repair**
- 11 Records**

- Appendix Parameter Access Tables**
 - Actuator Wiring Diagrams**
 - Basic Module, (200-500)
 - Module + Remote Board, (200-400)
 - Module + Remote Board + Data Logger, (200-410)

1. INTRODUCTION

The Modbus Module fitted to the IQ actuator is fully compatible with the Modbus RTU communications protocol using either a 2 or 4 wire RS485 serial highway. The IQ Modbus Module forms an integral part of the IQ actuator and is housed within the main double sealed electrical housing of the actuator. The electrical housing need never be opened once the actuator leaves the assembly plant. All adjustments to the settings for the Module may be made via the Infra-red link using the actuator setting tool, communicator or via the RS485 highway.

The Module circuits do not impinge on the actuator control electronics, the actuator itself remains fully self protecting. The Module performs the tasks of RS485 interface, actuator data collection and the issuing of actuator commands.

A Modbus RTU master may command an IQ actuator fitted with the Modbus Module to open, stop, close or perform an ESD operation. Additionally, digital and analogue status information relating to the actuator is available for the host to read. As an option, the actuator may be fitted with an I/O board which make available four digital relay outputs and as many as six auxiliary digital inputs. Other build options include fitting a datalogger card which records historical data about the actuator and the ability to fit two Modules to give fully redundant operation.

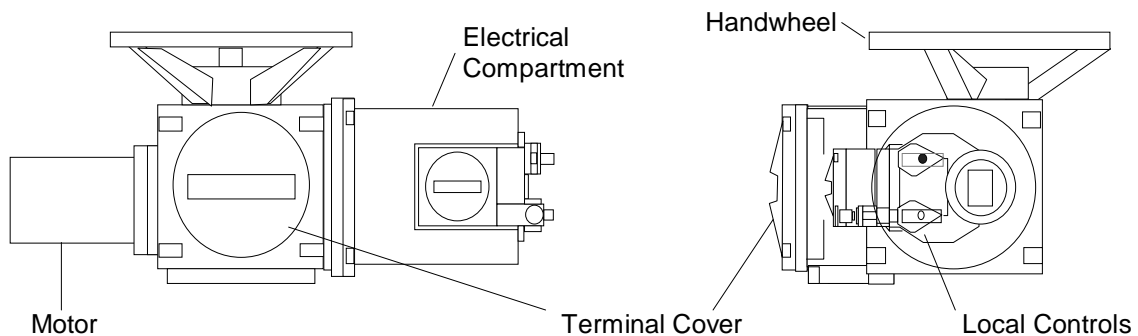

Fig 1: The IQ Actuator

2. MODBUS MODULE PROPERTIES

2.1 Mechanical Properties

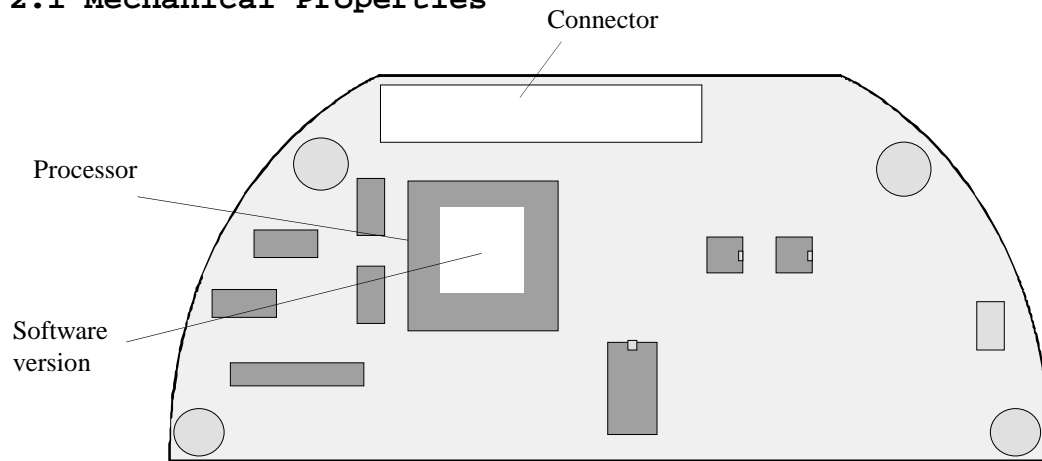

Fig 2: The Modbus Module

The Module comprises of a single printed circuit board that fits inside the actuator electrical housing. It connects to the main board of the actuator by a multipin connector and due to its physical shape the Module may only be fitted in the correct polarization. The actuator internal wiring harness has connections to the Module for RS485 serial highway connection via the actuator terminal bung, the isolated supply voltages for the Module and the remote auxiliary inputs. These connectors are polarized to prevent incorrect connection.

The Module connects either directly to the main pcb or indirectly through the Data Logging Module when the Data Logger option is fitted to the actuator.

2.2 Electrical Properties

The Module processor circuits connect directly to the main processors of the actuator. The Module does not sit in the main control path for the actuator and does not affect the actuator control integrity. The Module processor is controlled by a program stored internally. The processor is located on the Module board and marked as shown on the diagram. The software version is indicated on the label fitted to the processor. Additionally the circuit includes a non-volatile EEPROM that is used to store parameter settings that contain information about the Module settings.

The RS485 interface electronics is also on the Module board. The communications interface circuits are fully isolated from the Module processor and actuator electronics.

2.3 Operation and Storage

The Module is designed to be stored in the actuator and operated within the same environment as the actuator.
The constraints are:

Operating temperature:	-40°C to +70°C
Storage temperature:	-50°C to +85° C
Relative Humidity:	5% to 95% (<50°C) non-condensing

3. FITTING THE MODULE

The Module is factory fitted inside the IQ actuator. It is located as indicated in figure 3.

The Module has seven cable loom connectors, (SK2 to SK8), as well as a connector, (SK1), for plugging directly into the main board. Where a Data Logger board is fitted to the actuator then the Module plugs into the Data Logger board instead of the main board.

(SK2 connects the power Module 24 V dc to the Module)

(SK3 connects the terminal bung connections to the Module)

(SK5 + SK4 connect the Module to the remote board SK2 when the main board drives the relays R1 to R4)

(SK5 + SK7 connect the Module to the remote board SK2 when the Module is used to drive relays R1 to R4)

(SK6 carries the main control signals to/from the main board SK6)

(SK8 connects the Module to the data logger SK2)

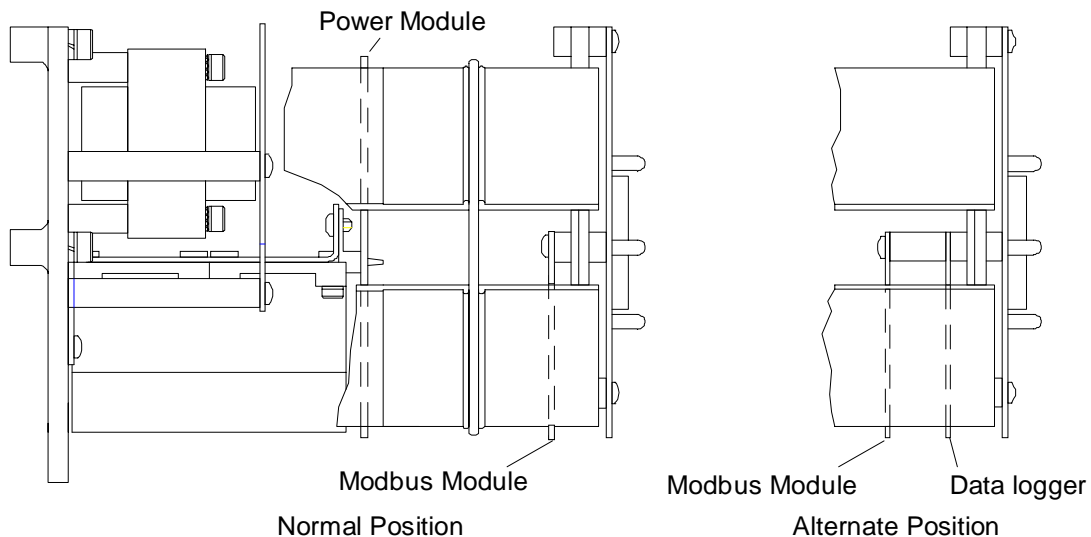

Fig 3: Positions of IQ PCB's

3.1 Replacing or Fitting a Modbus Module

The Module can be replaced or fitted only in a suitable environment. The actuator must be made electrically safe before opening any covers. The electrical housing cover should be removed and the existing Module carefully unplugged from its connector. Once removed from the main connector the wiring loom connectors should be removed. The replacement board is fitted in the reverse order to removal.

If the operation is to fit a Module for the first time then the correct wiring looms must be added to the internal wiring harness according to the above description.

Once fitted the actuator should be re-assembled and the Module parameters set.

3.2 Remote Input Board

The standard basic IQ actuator with Modbus Module is built to wiring diagram 200-500, (ref page 53). This build does not include the Remote Input Board which supports the auxiliary digital inputs and outputs. When specifically requested this board can be fitted to enable the Remote Auxiliary Input signals to be passed to the Module as well as providing the Module with facility of 4 volt free outputs.

3.3 Fitting a Remote Input Board

The procedure is similar to fitting a Modbus Module. First make the actuator electrically safe, then remove the electrical housing cover. The wiring harness will already have connectors to permit the Remote Input Board wiring to be connected. Place the board in the correct position and fit the wiring loom connectors. Re-assemble the actuator and test the input functions. The Modbus Module parameters for the remote input functions will require setting.

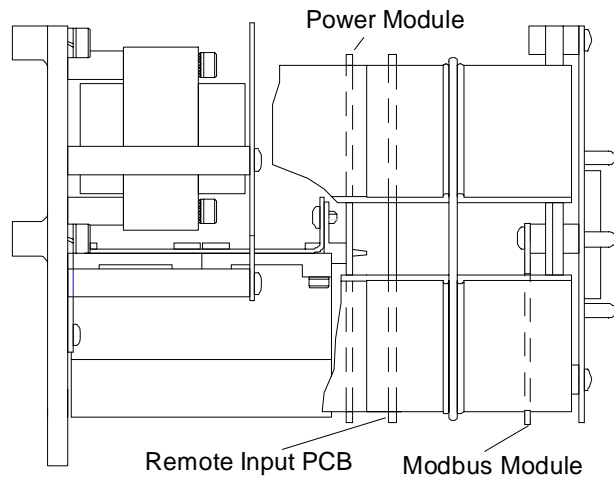

Fig 4: Position of Remote Input Board

3.4 Dual Redundancy

Dual redundancy can be achieved by fitting a second board on top of the first as shown in fig 5. The fitting procedure is the same as described in section 3.2. Note that with this option the Data Logger cannot be fitted. Also with dual redundancy only a 2 wire RS485 communications highway can be used.

Jumpers J3, J4 and J5 should be set to “A” on one module and “B” on the other. The IQ Setting Tool is only able to configure the “A” Module. The IQ Communicator and the Modbus host are able to configure both “A” and “B” Modules (according to the table in section 8).

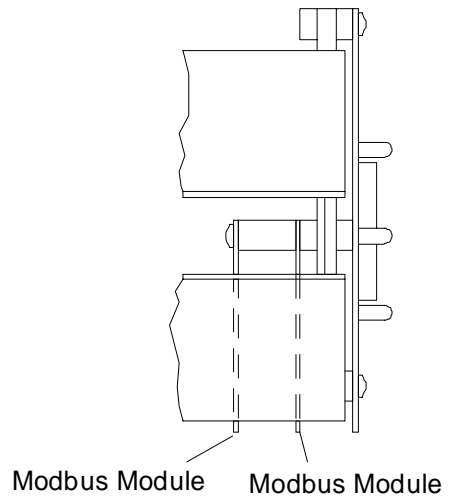
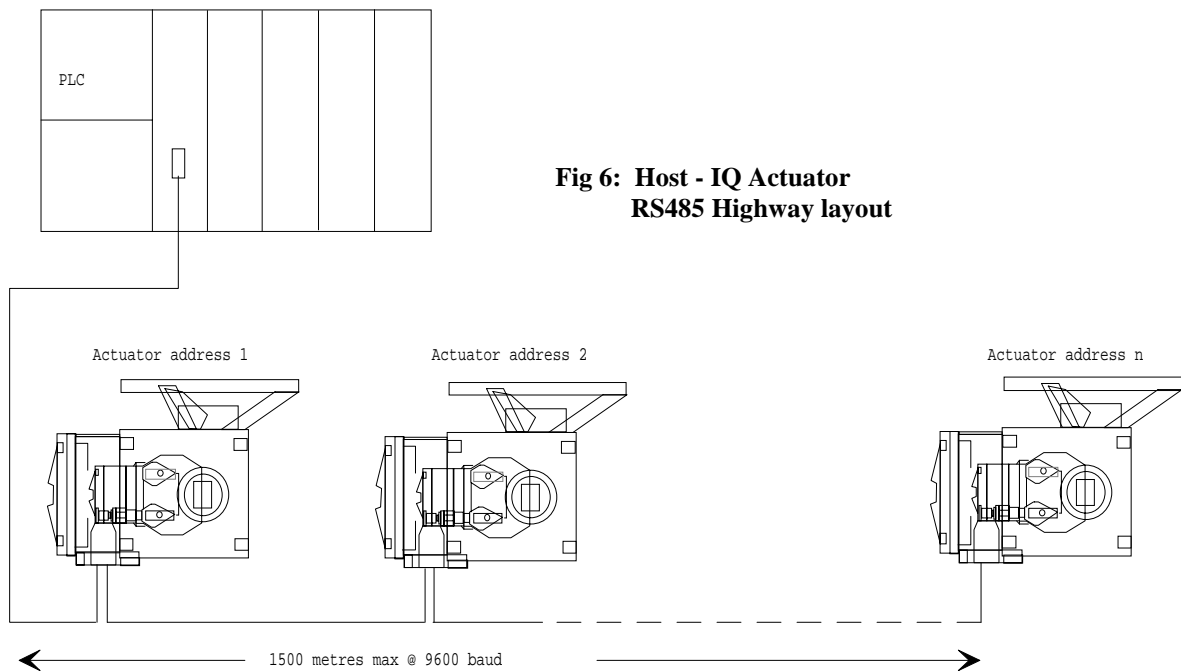

Fig 5: Modbus Module - Dual Redundancy Set

4. RS485 2/4 WIRE CONNECTIONS

The Modbus Module uses a half duplex, multi-point, serial communications standard using a balanced pair of wires as defined in the Electronics Industry Association standard, (EIA-485), for RS485. The Module can communicate to a host system using its RS485 interface and can operate in either 2 or 4 wire mode. The system set up is as shown below in fig 6.



**Fig 6: Host - IQ Actuator
RS485 Highway layout**

The addresses can be in any order and up to 32 devices can be connected without the need for repeaters.

There are separate receive and transmit connections on the actuator terminal bung which can be used individually for 4 wire mode or for 2 wire mode, (see figs 7 and 8 overleaf).

Termination resistors, normally around 120 Ohms, usually have to be fitted at each end of the RS485 highway in order to balance the lines and to avoid signal reflection. These resistors have to be fitted externally as there is no facility on the Module itself for line termination.

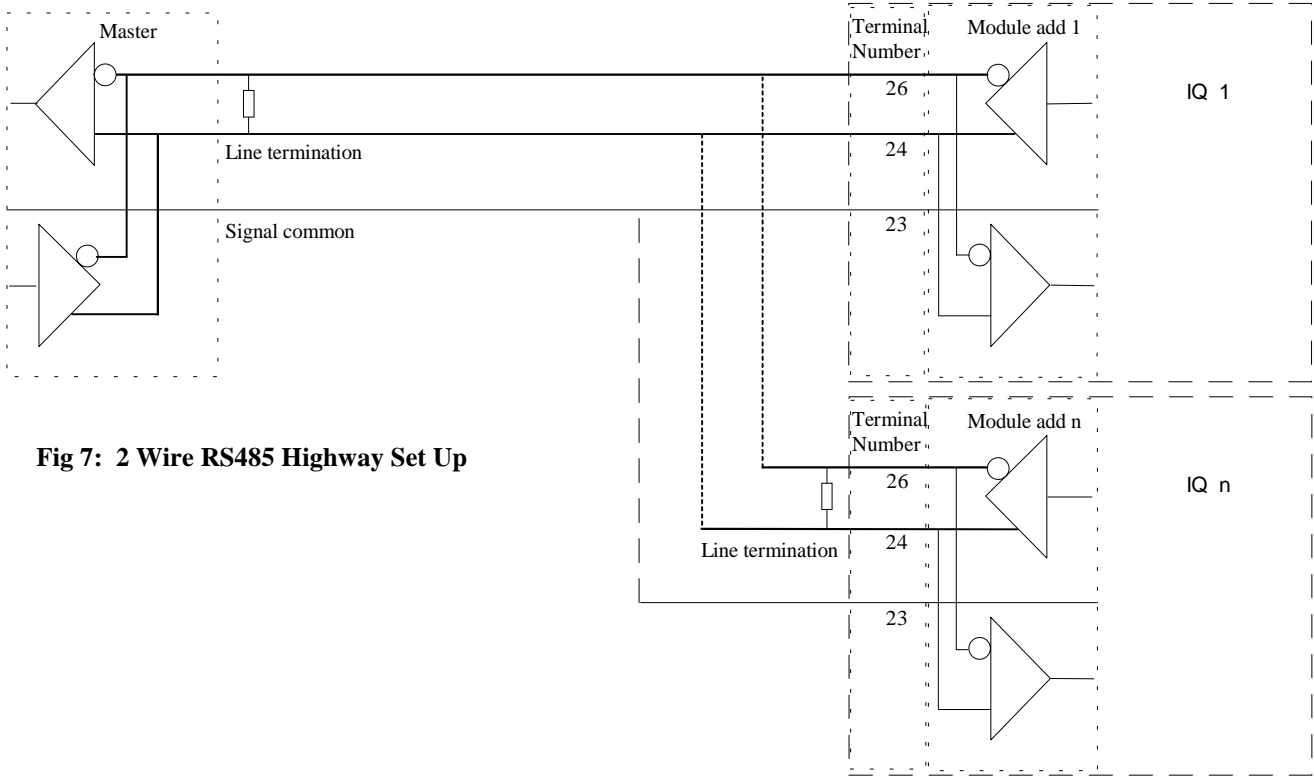

Fig 7: 2 Wire RS485 Highway Set Up

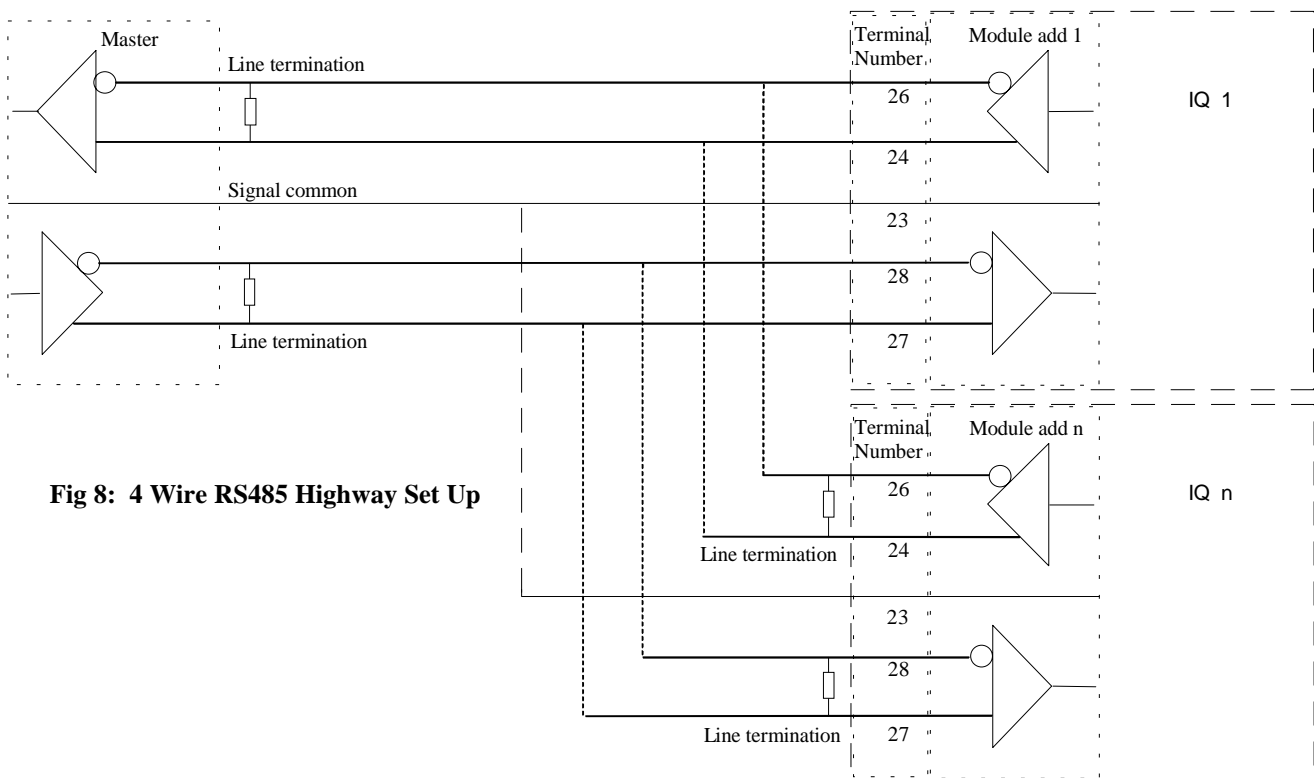

Fig 8: 4 Wire RS485 Highway Set Up

5. MODBUS MODULE CONFIGURATIONS

5.1 Basic Module, (200-500) - Single Modbus Module without auxiliary I/O

IQ actuators built to wiring diagram 200-500, (ref page 54), incorporate Modbus Module part number 39243 which schematically fits within the actuator electronics as shown below in fig 9;

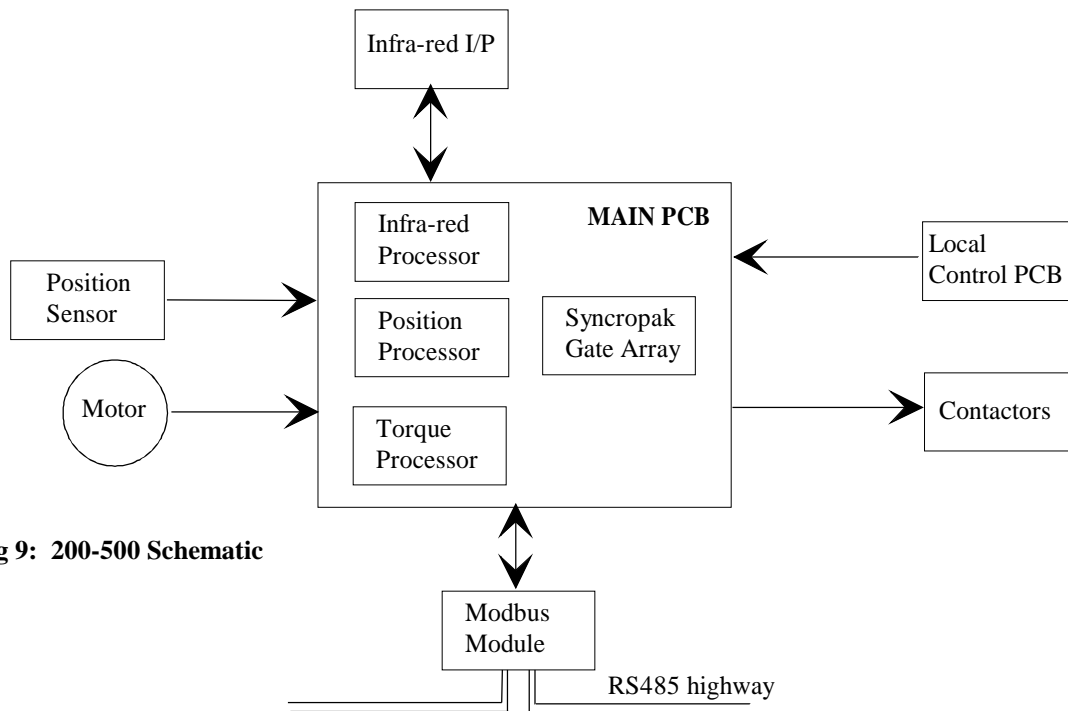

Fig 9: 200-500 Schematic

Modbus Module board 39243 offers the following control and feedback features;

- | | | |
|----------------|---|-----------------------------|
| Digital Inputs | - | Centre column moving |
| | - | Close limit switch |
| | - | Open limit switch |
| | - | Thermostat tripped |
| | - | Monitor relay |
| | - | Local control selected |
| | - | Remote control selected |
| | - | Battery low |
| | - | MIT active |
| | - | Clockwise contactor ON |
| | - | Anti-clockwise contactor ON |
| | - | Interrupter timer |
| | - | Position control enabled |
| | - | Error |
| | - | S1 * |
| | - | S2 * |
| | - | S3 * |
| | - | S4 * |

Digital Outputs	-	OPEN
	-	STOP
	-	CLOSE
	-	ESD
Analogue Inputs	-	Measured position
	-	Current torque
Analogue Outputs	-	Desired position

For a complete description of the above signals refer to section 6

N.B.

- * - S1 to S4 are the logic signals supplied by the main PCB which can be configured and sent out even if the switches S1 to S4 are physically not present. (For S1 to S4 options see section 6.1.14).

5.2 Basic Module + Remote Board, (200-400) - Single Modbus Module with auxiliary I/O

The IQ 200-400 Modbus Module uses a 39244 board and schematically fits within the actuator electronics as shown below in fig 10 - ref. wiring diagram on page 55. (The 39244 board includes the power supply isolation required to maintain power isolation integrity when actuator remote inputs or outputs are used). Modbus Module board 39244 offers the following control and feedback features;

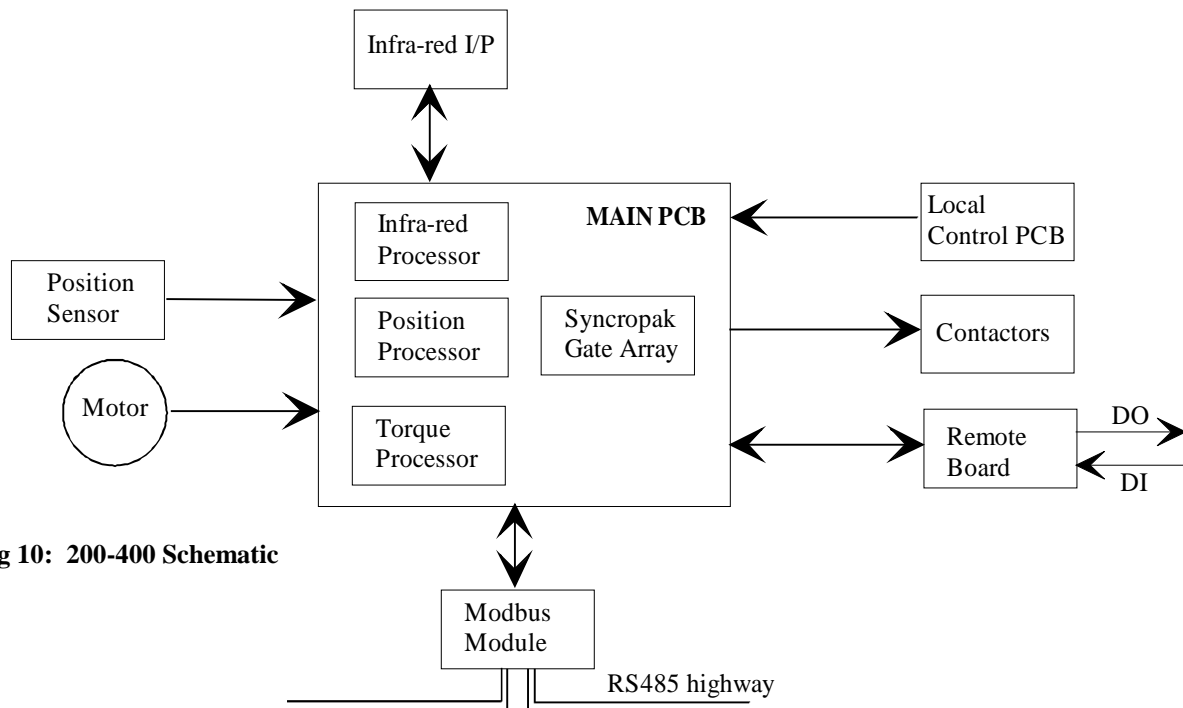

Fig 10: 200-400 Schematic

- Digital Inputs -
- Centre column moving
 - Close limit switch
 - Open limit switch
 - Thermostat tripped
 - Monitor relay
 - Local control selected
 - Remote control selected
 - Battery low
 - MIT active
 - Clockwise contactor ON
 - Anti-clockwise contactor ON
 - Interrupter timer
 - Open Interlock
 - Close Interlock
 - Position control enabled
 - Error

Digital Inputs, (continued)

- S1 *
- S2 *
- S3 *
- S4 *
- Aux I/P 1 **
- Aux I/P 2 **
- Aux I/P 3 **
- Aux I/P 4 **

Digital Outputs

- OPEN
- STOP
- CLOSE
- ESD
- Relay 1 ***
- Relay 2 ***
- Relay 3 ***
- Relay 4 ***

Analogue Inputs

- Measured position
- Current torque

Analogue Outputs

- Desired position

For a complete description of the above signals refer to section 6

N.B.

- * - S1 to S4 are the logic signals supplied by the main PCB which can be configured and sent out even if the switches S1 to S4 are physically not present. (For S1 to S4 options see section 6.1.14).
- ** - These are the remote signals that can be used either as digital inputs or for actuator control
- *** - These are the actual relay outputs, controlled by the Modbus Module rather than the main PCB logic.

5.3 Module + Remote Board + Data Logger, (200-410) - Single Modbus Module with auxiliary I/O and Data Logger

The IQ 200-410 Modbus Module uses a 39244 board and schematically fits within the actuator electronics as shown below in fig 11 - ref wiring diagram on page 56;

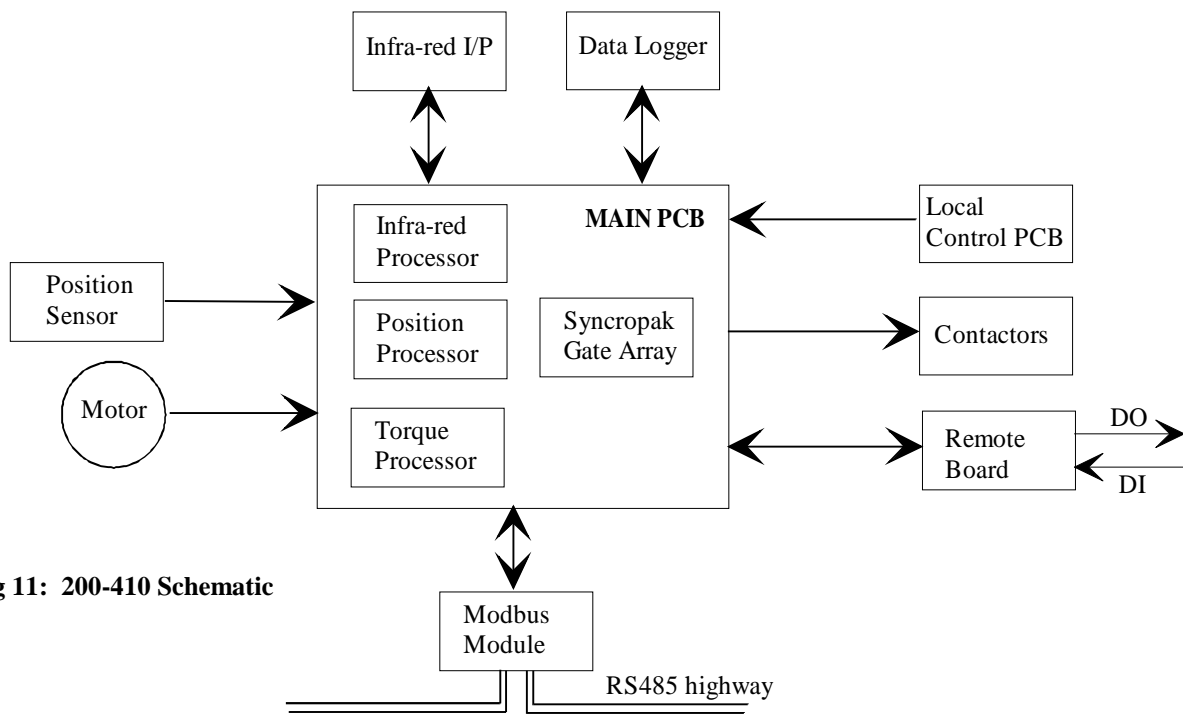

Fig 11: 200-410 Schematic

Modbus Module board 39244 offers the following control and feedback features;

- Digital Inputs -
- Centre column moving
 - Close limit switch
 - Open limit switch
 - Thermostat tripped
 - Monitor relay
 - Local control selected
 - Remote control selected
 - Battery low
 - MIT active
 - Clockwise contactor ON
 - Anti-clockwise contactor ON
 - Interrupter timer
 - Open Interlock
 - Close Interlock
 - Position control enabled
 - Error

Digital Inputs, (continued)

- S1 *
- S2 *
- S3 *
- S4 *
- Aux I/P 1 **
- Aux I/P 2 **
- Aux I/P 3 **
- Aux I/P 4 **

Digital Outputs

- OPEN
- STOP
- CLOSE
- ESD
- Relay 1 ***
- Relay 2 ***
- Relay 3 ***
- Relay 4 ***

Analogue Inputs

- Measured position
- Current torque

Analogue Outputs

- Desired position

Register Inputs

- Data logger NVRAM

For a complete description of the above signals refer to section 6

N.B.

- * - S1 to S4 are the logic signals supplied by the main PCB which can be configured and sent out even if the switches S1 to S4 are physically not present. (For S1 to S4 options see section 6.1.14).
- ** - These are the remote signals that can be used either as digital signals or for actuator control
- *** - These are the actual relay outputs, controlled by the Modbus Module rather than the main PCB logic.

6. INPUT AND OUTPUT SIGNALS

The following section describes the inputs and outputs of the Modbus Module, plus the possible uses of the remote actuator inputs. In all cases feedback data is considered to flow from the actuator to the host PLC and command data is considered to flow in the reverse direction, i.e. inputs are feedback signals and outputs are commands.

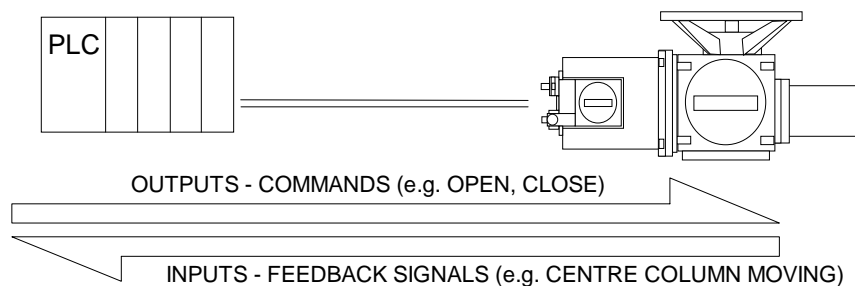

Fig 12: Input and Output Data Directions

6.1 Digital Inputs

6.1.1 Centre Column Moving

The actuator senses any movement of its centre column whether this is generated by a manual (hand) operation or by the action of the motor. Whenever the centre column is in motion this bit is set to a logic 1.

6.1.2 Close Limit Switch / Open Limit Switch

There are two data bits relating to the actuator set positions for open and close positions. These limit positions may be set within the actual valve stroke. When a torque seating valve is closing, the actuator will stop when the seat is reached and the rated torque has been delivered, independent of the closed limit switch setting. The position limit switch must be set slightly before the torque off position so as to ensure that the position is correctly reported.

The data relating to position is maintained even though the position itself has been passed through.

When the actuator has reached the closed or open limit the respective bit will be set to a logic 1

6.1.3 Thermostat tripped

The actuator motor is protected by a thermostat, if the temperature of the motor windings rises above the thermostat trip value, the thermostat contact will open and this bit will be set. There are no adjustments for the temperature at which the thermostat trip operates. The motor will be stopped if the thermostat trips. Only once the motor has cooled down and the thermostat has reset itself can a new Remote, Host or Local command to move the actuator Open or Closed be actioned. The ESD command may be set to override the thermostat. The bit will remain set at logic 1 until the motor cools down and the thermostat resets itself.

6.1.4 Monitor Relay

The actuator includes a composite signal for some alarms referred to as the Monitor Relay. This bit will be set to logic 1 if the actuator selector is in Local or Local Stop (not in Remote) or if the thermostat trips. The actuator also monitors the 3 phase supply and if the phase not associated with the control circuits is lost the monitor relay bit is set. The remaining two phases are used by the control circuits and if either of these is lost at any time then the actuator switches off. Communication with the Modbus Module unit will then be lost.

6.1.5 Local Selected

The actuator has a 3 position switch for selecting Remote, Local Stop or Local Control. The switch passes from Remote to Local, or Local to Remote, through the Local Stop position. When the actuator local control switch is fully in the Local position then this bit is set to logic 1. This data bit is not present when the actuator control switch is in the Local Stop or Remote positions. The bit is present as long as the switch is in the Local position and it will clear only when the switch is returned to the Remote or Local Stop position.

6.1.6 Remote Selected

This data bit is similar to the Local selected bit in that when the actuator local control switch is fully in the Remote position then this bit is set to logic 1. This data bit is not present when the actuator control switch is in the Local Stop or Local Control positions. The bit is present as long as the switch is in the Remote position and it will clear only when the switch is returned to the Local Stop or Local Control position.

6.1.7 Battery Low

The IQ actuator is fitted with a battery that is used to power the circuits used to keep track of the valve position when the actuator mains power is switched off. This battery is used only when the actuator has no power feed and the valve is actually moved. The condition of the battery is monitored at all times and a signal generated if the battery power is low.

The Modbus Module reports the condition of the battery as a logic 1 when the battery voltage falls below a critical value.

Note that the field unit can only report information if the actuator is powered on.

6.1.8 MIT (Motion Inhibit Time) active

Motion Inhibit Time is the time that the actuator inhibits motor operation, after it has stopped, in order to prevent the actuator exceeding its rated starts per hour. This bit is set after the positioner reaches the required position and has stopped. It stays active for the MIT time during which the positioner outputs are disabled.

6.1.9 Clockwise Contactor On / Anti-clockwise Contactor On

There are two data bits relating to which one of the internal contactors is energised. If the contactor which causes the actuator to run in the clockwise direction is energised then “Clockwise Contactor On” is set to logic 1. Likewise if the contactor to run the actuator anti-clockwise is energised then “Anti-clockwise Contactor On” will be set to logic 1.

These signals will be reported whenever the contactor energises regardless of whether the command was issued from the host system, the local control knob or the remote pushbuttons that can be fitted. These signals provide indication only that a contactor is energised. Assuming that the actuator is functioning normally, the motor will also be running, however, these bits do not provide a true indication of this.

Note: These signals provide no indication that the motor is rotating.

6.1.10 Interrupter Timer

This feature gives automatic pulsed operation of a valve to reduce the effective speed of travel. The timer can be configured to operate over a percentage of travel in the opening and closing directions and the length of each ON and OFF pulse is configurable in the range 1 to 99 seconds using the setting tool. (Using a communicator, much wider timing range can be configured, i.e. up to 4 ½ hours).

If for example, the interrupter timer has been set and the actuator is travelling closed, during the periods when the actuator is not moving due to the interrupter timer, this bit will be set to logic 1.

6.1.11 Open / Close Interlocks

Interlocks provide a means of inhibiting an actuator from opening or closing, even when commanded to do so, until a “safe to move” signal is applied via the interlock input, thus preventing an illegal valve movement. These two bits reflect the state of the interlock inputs and are only available if the Remote Input Board is fitted. When the interlock facility is enabled a hard wired signal needs to be applied to the correct terminal, in addition to the control signal, before the actuator moves in the required direction. The two interlock inputs also appear as Module input status bits, with the bit being set when the input is energised. If the interlock facility is turned off, the “interlock” signals can be used for reporting two additional digital general status inputs, via the Module, to the host system.

6.1.12 Position Control Enabled

If the actuator is operating in positioning mode, this bit will be set.

6.1.13 Error

Upon detection of a Module fault this bit will be set. Interrogation of the Module using the loopback test is needed to determine the cause of this error.

6.1.14 S1 to S4

The logical four contacts S1 to S4 can be configured to make or break for one of the following functions, (see publication E170E - IQ Installation Instructions), and will be reported as logic 1 for made;

- An intermediate or end position
- Torque trip in mid travel
- Actuator closing
- Actuator opening
- Actuator output rotating
- Motor stalled
- Battery low
- Hand operation
- Blinker

Note that the Actuator closing and opening signals give a true indication of actuator travel. The Clockwise and Anticlockwise contactor bits, (8.1.6), only indicate which contactor has been energized. (If only the clock and anticlockwise bits are used, knowledge of how the actuator has been set up is needed before actuator opening or closing can be determined).

6.1.15 AUX Inputs 1 to 4

The Auxiliary inputs may report as a logic 1 or 0 for the input contact being a closed circuit. The decision as to whether a 1 or 0 is reported is made by the setting of the relevant data bit in the invert mask, (settable with either the setting tool or communicator). Bits 0-3 relate to inputs AUX 1 - 4. If the bit in the mask is set to 0 then the data reported is a logic 0 when the contact source is closed, if the mask bit is set to 1 then a closed contact source is reported as a 1.

The Auxiliary inputs may also be used as a secondary control point for the actuator in which case they are designated as 'Remote Open', 'Stop/Maintain', 'Remote Close' and 'ESD' signals. In order to invoke the use of these signals as 'remote command inputs' the invert mask bits 5-8 must be set to '1' for the inputs being used. Note that by using both invert mask bit 0 and bit 4 set to '1' results in Aux 1 being used as a 'Remote Open' command - a closed contact causes the actuator to run open.

6.2 Digital Outputs

6.2.1 Open/Close/Stop/ESD

The Module output Open, Stop and Close commands are actioned by the actuator, providing that the actuator is available for remote operation, (i.e. Monitor relay = 0),. When the Module issues a command the actuator actions it until another command is issued or the instruction has been completed. For example the Module will issue a command to 'open' the valve, the actuator will then action this command until the valve is fully open or until a close or stop command is issued from the Module, whichever is the sooner. Any of these commands will cause the actuator to drop out of local positioning mode.

For most commands the last received takes priority. However, for the case where two signals can be received at the same time, e.g. via the Aux I/P's, their priority is selectable via the setting tool or communicator. If the output coils are energised by a register write, the Module does not require the command to be cancelled before another is issued as this is done automatically by the command. However, if a coil write is used to energise an output coil, the command has to be cancelled before a new one is issued, otherwise two commands are received by the Module at the same time and the priority setting will determine the actuator action.

If multiple commands are sent to the same Module the command received last will be obeyed. It is acceptable to reverse the actuator in mid travel without issuing a stop command.

Note: The commands to the actuator are assigned priorities as shown above in fig 13. (The priorities for Auxiliary and Host OPEN and CLOSE inputs are selectable via the setting tool).

High Priority	⇔⇔⇔⇔⇔⇔	⇔⇔⇔⇔⇔⇔	⇔⇔⇔⇔⇔⇔	Low Priority
Local Stop	Aux Input ESD	Local Close	Aux Input Close	Host Close
	Host ESD	Local Open	Aux Input Open	Host Open
			Aux Input Stop	Host Stop

Fig 13: Command Priorities

6.2.2 Relays 1 to 4

When the Remote board is fitted, the Modbus Module is able to drive the 4 output relays , via a simple bit or register write operation.

6.3 Input Registers

6.3.1 Torque Feedback

Data relating to the current value of torque being developed by the actuator is available from the Module. Whilst the actuator motor is stationary this signal will remain as the last value measured. When the motor is running the signal will be in the range 0-120%, with a 1% resolution. There are no ranging adjustments required for the signal as it is pre-calibrated by the actuator settings, the signal is a percentage of rated actuator torque.

6.3.2 Position Feedback

The IQ actuator always includes an internal continuous valve position monitor. The data about the valve's position is fed to the Module for onward transmission as a Valve position feedback signal (0-100%) with a resolution of 0.5%. There are no ranging adjustments required for the signal as it is pre-calibrated by the limit switch settings of the actuator itself.

Usually the actuator will be forward acting and the 0% value will correspond to the Close limit switch setting and 100% to the Open limit switch setting. In some cases the actuator itself may be configured so as to be reverse acting, 0% equal to fully open, under this configuration mode the Module will automatically modify its reported data to align with the revised setting of the actuator. The 0% reading will be returned when the actuator is Open.

If the valve is torque seating then the torque off point position should be set very close to the limit switch setting so as to minimise the actual position error.

6.4 Output Register

6.4.1 Actuator Control

By writing either a 01, 02 03 or 04 to the actuator control register the actuator can be commanded to either STOP, CLOSE, OPEN or ESD.

6.4.2 Position Demand

Position control should be used on forward acting actuators only, i.e. actuators where closed = 0% and open = 100%. The Module is able to accept a 'Desired Value' signal to cause the actuator to move to a particular position in the valve stroke. The action of sending a DV signal to the Module places it in 'positioning mode'. The positioning signal must be in the range 0-100% where 0% is towards the close position of the valve. Once a desired value has been sent the Module will maintain control of the actuator until it reaches the deadband limit of the desired value where it stops the motor and drops out of positioning mode, i.e. position demand is a "one time" event. Once actioned and completed, (or cancelled), the actuator will not attempt to re-achieve the same position until sent a new command.

When the actuator has been set for limited range position reporting it will take the 0-100% position range over a portion of the total valve stroke. If a Desired Value position is sent to the actuator it will use the same limited range for positioning the actuator as it uses for reporting the actual position.

The command to the Module from the RS485 highway is a momentary 'write' of data for the Desired Value. Once initiated the Module does not require the command to be cancelled before another is issued. The positioning command to the Module is able to be read back on the RS485 highway.

It is acceptable to send a new Desired Value at any time, there is no need to issue a stop command or cancel the existing value. If a full travel command (such as Open, Stop or Close) is sent to the Module this will cause the Desired Value command to be removed and replaced with the most recent command.

A Remote Auxiliary Control input becoming active will cancel the position control action.

6.4.3 Deadband - (for Position Demand)

The control algorithm used for the Module unit positioner is proportional only. The Module runs the actuator to the desired position then stops it and drops out of positioning mode. As the actuator and valve combination will have some inertia it is possible that the desired position may be 'overrun'. To prevent this from happening there is a Deadband setting whereby once the actuator enters the deadband the motor will be stopped. For example a 5% deadband will cause the motor to be stopped once the actual position is within 5% of the desired position. The inertia will then bring the actual position nearer to the desired position.

It is important to set the deadband such that the actuator does not overrun the control point.

6.4.4 Motion Inhibit Timer

The setting of the Motion Inhibit Timer is the period that must elapse between the actuator stopping and then restarting. This idle period will prevent the actuator motor exceeding its rated starts per hour.

6.4.5 Minimum and Maximum Position

It is possible to make the position data reported relate to a reduced span of actual valve travel. In this mode the position data relates to a reduced portion of the valve stroke. This is sometimes used where the valve is required to have a 0% position (or 100% position) that is not the same as fully closed and fully open, e.g. see fig 14 below). To make the actuator take note of limited range position reporting it is necessary to set the Position-Minimum and Position-Maximum range using a Setting Tool, Communicator or host system. The default is always 100% reporting of position from fully open to fully closed limit switch positions.

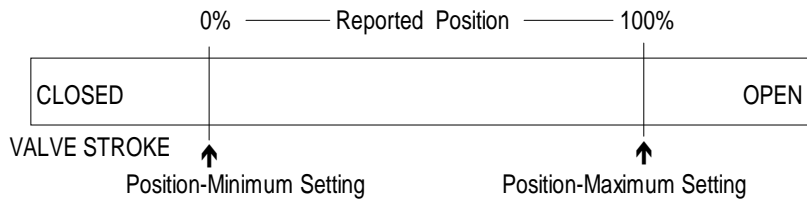

Fig 14: Limited Range Position Reporting

6.5 Additional Signals

6.5.1 Remote Auxiliary Control Inputs

Provided the remote board is fitted, some or all of the four auxiliary input signals may be used as remote control inputs to operate the actuator. For the OPEN, CLOSE and STOP inputs to be actioned the actuator selector switch must be set in Remote, However, for ESD the actuator can be either in Local or Remote.

The function of the four inputs are predefined when they are used as control inputs as shown below. Note that a mixture of control inputs and data reporting inputs is acceptable. Control inputs are either maintained or momentary contact closures, depending on the setting of the STOP/MAINTAIN input, and the Module and actuator control circuit translates the input into a command to move the valve.

- AUX 1 - REMOTE OPEN
- AUX 2 - REMOTE CLOSE
- AUX 3 - REMOTE STOP/MAINTAIN
- AUX 4 - EMERGENCY SHUT DOWN

The Auxiliary Input Configuration Mask must be enabled for the desired function to be set into the actuator. When this is suitably set the Remote Auxiliary Inputs will be Remote Auxiliary Control inputs. These controls override any existing host system command or Position control action except for a host system ESD command.

Note: The commands to the actuator are assigned priorities as shown above in fig 15. (The priorities for Auxiliary and Host OPEN and CLOSE inputs are selectable via the setting tool).

High Priority	⇔⇔⇔⇔⇔⇔	⇔⇔⇔⇔⇔⇔	⇔⇔⇔⇔⇔⇔	Low Priority
Local Stop	Aux Input ESD	Local Close	Aux Input Close	Host Close
	Host ESD	Local Open	Aux Input Open	Host Open
			Aux Input Stop	Host Stop

Figure 15: Command priorities

7. MODBUS SUPPORT

This section covers the implementation of the Modbus protocol and is based on the information contained within the Gould Modbus Protocol - Reference Guide PI-MBUS-300 Rev C. January 1991.

Modbus commands may be transmitted to the Modbus Module using RTU protocol via the 2/4 wire RS485 interface and it responds as a MODBUS SLAVE to messages from the host.

7.1 Modbus Specification

7.1.1 Electrical Specification

Line electrical specification RS485- (2 or 4 wire)

7.1.2 Outer Protocol

Modbus transmission mode RTU (8 bit binary data)
 Baud rate 110, 300, 600, 1200, 2400, 4800, 9600, 19200 or 38400

Number of bits per character

start bits	1
data bits, (LSB first)	8
Parity	Odd, Even or None - (no parity bits sent if none is selected)
Stop bits	1 or 2

Error checking CRC

Message timeouts	110	-	382 ms
	300	-	140 ms
	600	-	70 ms
	1200	-	35 ms
	2400	-	17.5 ms
	4800	-	8.75 ms
	9600	-	4.375 ms
	19200	-	2.2 ms
38400	-	1.1 ms	

7.1.3 Modbus Address

Whilst only 32 physical nodes can be present on any single segment, addresses up to 247 can be used. Address 0 is reserved for broadcast messages. If more than 32 nodes are to be used on a single highway, external repeaters will have to be used.

7.2 Modbus Function Code Support

The Modbus codes supported by the Modbus Module are listed in the table below;

Function Code	Modbus Name	Addressing	Section
01	Read Output Status	Discrete	9.1
02	Read Input Status	Discrete	9.2
03	Read Output Registers	Register	9.3
04	Read Input Registers	Register	9.4
05	Force Single Coil	Discrete	9.5
06	Pre-set Single Register	Register	9.6
07	Read Exception Status		9.7
08	Loopback Test		9.8
15	Force Multiple Coils	Discrete	9.9
16	Force Multiple Registers	Register	9.10
17	Report Slave ID		9.11

Table 1: Modbus Codes Supported

7.2.1 Read Output Status, (Function Code 01)

This function allows the user to obtain the ON/OFF status of the digital outputs. 4 outputs are available with the basic Module with an additional 4 relay outputs provided when the optional remote board is fitted. The outputs are mapped as shown in table 2.

A maximum number of 8 coils are therefore available at a single request

Coil Number	Function
0	Remote stop/maintain
1	Remote close
2	Remote open
3	ESD / Thermostat bypass
4	Relay 1
5	Relay 2
6	Relay 3
7	Relay 4

Table 2: Digital Outputs

A typical host query to read coils 0 to 3 from slave address 17 would be as follows;

Address	Funct'n code	Start Pt Ho	Start Pt Lo	# Pts Ho	# Pts Lo	Check
11	01	00	00	00	04	CRC

The reply, assuming that the remote close and remote maintain were logic 1 would be;

Address	Funct'n code	Byte Count	Data	Check
11	01	01	03	CRC

The data is packed with 1 bit for each coil. In the case of coils 0 - 3 a logic 1 indicates a signal applied and for coils 4 - 7 the relay status is ON. The low order bit of the data byte contains the first addressed coil and the remainder follow. If less than 8 coils are requested, unused bits at the top end will be filled with zeros.

7.2.2 Read Input Status, (Function Code 02)

This function allows the user to obtain the ON/OFF status of digital inputs. All of the digital inputs to the controller are mapped into this database, including the optional 4 isolated inputs from the remote board. The inputs are mapped as shown in table 3

I/P Number	Function
0	Centre column moving
1	Close limit switch
2	Open limit switch
3	Thermostat tripped
4	Monitor relay
5	Local selected
6	Remote selected
7	Battery low
8	Clockwise contactor on
9	Anti-clockwise contactor on
10	Interrupter timer
11	MIT active
12	Open interlock
13	Close interlock
14	Position control enabled
15	Error
16	S1
17	S2
18	S3
19	S4
20	Aux Input 3 (remote maintain)
21	Aux Input 2 (remote close)
22	Aux Input 1 (remote open)
23	Aux Input 4 (remote ESD)

Table 3: Digital Inputs

To read the status of all of the digital inputs of actuator 17, the following command would be issued by the host:

Address	Funct'n code	Start Pt Ho	Start Pt Lo	# Pts Ho	# Pts Lo	Check
11	02	00	00	00	18	CRC

As with function code 01, the data is packed one bit for each input, with the addressed data in the least significant bit position. However, the byte order is returned as most significant byte first, i.e. least significant byte last. The reply to the above command would be in the following format:

Address	Funct'n code	Byte Count	Data M.S.Byte bits 23 - 16	Data bits 15 - 8	Data L.S.Byte bits 7 - 0	Check
11	02	03	XX	XX	XX	CRC

As an example; assuming that the the following bits are true, i.e. = 1
 centre column moving, / remote selected, / anti-clockwise contactor on,
 position control enabled / S1.
 all other bits are not true, i.e. = 0

The following reply would be returned to the above message

Address	Funct'n code	Byte Count	Data M.S.Byte bits 23 - 16	Data bits 15 - 8	Data L.S.Byte bits 7 - 0	Check
11	02	03	01	42	41	CRC

Any number of bits can be selected starting from anywhere within the data area, provided that attempts are not made to read beyond bit 23, (as this will return an error code). e.g. if, data in the range bit 3 to 14, from actuator address 17, were required, the request would be;

Address	Funct'n code	Start Pt Ho	Start Pt Lo	# Pts Ho	# Pts Lo	Check
11	02	00	03	00	0C	CRC

And the response would have the following format

Address	Funct'n code	Byte Count	Data M.S.Byte bits 14 - 11	Data L.S.Byte bits 10 - 3	Check
11	02	02	XX	XX	CRC

N.B. The data requested will be in the least significant data byte and the least 4 significant bits in the most significant data byte. The most significant 4 bits of the most significant data byte will have no relevance.

7.2.3 Read Output Registers, (Function Code 03)

This command provides access to the Actuator Control, the Position demand desired value, (set point), Deadband, Motion Inhibit Time and Maximum and Minimum position registers used within the Local Positioner Function as shown in table 4.

The actuator control register, (register 0), can be pre-set to one of four values using function code 6 or 16, to STOP, CLOSE, OPEN or ESD the actuator. When reading this register, either the most recently received value is returned or zero is returned if this register has not been previously pre-set.

Note: The value returned will NOT reflect whether will it reflect any actions carried out since the previous pre-set register command, due to force coils commands or the actuator local or remote controls for example.

The 4 valid values for the actuator control register, (register 0), are as shown in table 5

Register Address	Function	Range	Hex value
0	Actuator control	0 - 3	0 - 3
1	Position demand	0 - 100%	0 - FFFF
2	Deadband	0 - 25.5%	0 - 4147
3	Motion inhibit time	0 - 255 s	0 - FF
4	Minimum position	0 - 100%	0 - FFFF
5	Maximum position	0 - 100%	0 - FFFF

Table 4: Output Registers

the action was actually carried out nor

Value	Function
00	STOP
01	CLOSE
02	OPEN
03	ESD

Table 5: Actuator Control Register

As an example, to read the current value of the Deadband setting with actuator address 17, the following command would be used;

Address	Funct'n code	Start Pt Ho	Start Pt Lo	# Pts Ho	# Pts Lo	Check
11	03	00	02	00	01	CRC

and the reply would be in the following format;

Address	Funct'n code	Byte count	Data Ho	Data Lo	Check
11	03	02	0C	CC	CRC

In this case the reply indicates a Deadband setting of 5%

7.2.4 Read Input Registers, (Function Code 04)

This command provides access to the position and torque feedback information. Torque and position data are returned as a scaled 16 bit number. As such 100% position and 120% torque is always reported as 65535. The data is mapped as shown in table 6.

Register Address	Function
0	Torque feedback
1	Position feedback
2 - 255	Reserved
256 - 511	Reserved
512 - 767	Reserved
768 - 1023	Reserved

Table 6: Input Registers

Example

To read the position feedback of actuator address 17, the following command would be used;

Address	Funct'n code	Start Pt Ho	Start Pt Lo	# Regs Ho	# Regs Lo	Check
11	04	00	01	00	01	CRC

and the following reply generated;

Address	Funct'n code	Byte count	Data Hi	Data Lo	Check
11	04	02	35	35	CRC

This would correspond to a position of approximately 21%.

7.2.5 Force Single Coil, (Function Code 05)

Using this command the actuator can be requested to operate or, when fitted, the status of the optional relays can be changed. A data value of 65280, (FF00 HEX), will close the contacts on the selected relay or action the required command. A data value of 0 will open the contacts or remove the control signal. With coils 0 to 3 the contacts must be opened before another can be closed. A data value other than 0 or FF00 will return an error code response.

Note: These coil outputs are maintained and must be removed by a serial data command before another energise coil command is sent. They are not removed by putting the actuator into Local or Local Stop.

Coil Number	Function
0	Remote stop/maintain
1	Remote close
2	Remote open
3	ESD / Thermostat bypass
4	Relay 1
5	Relay 2
6	Relay 3
7	Relay 4

Table 7: Coil Addresses

The outputs are mapped as shown in table 7.

As an example, to energize and maintain the remote close input to actuator 17, the following command should be generated by the host;

Address	Funct'n code	Start Pt Ho	Start Pt Lo	Data	Data	Check
11	05	00	01	FF	00	CRC

In response to this message, the actuator will change the state of the selected output and then return the message to the host as confirmation. It should be noted that writing to any of the 4 control bits will cause the actuator to drop out of positioning mode if that mode had previously been selected.

7.2.6 Pre-set Single Register, (Function Code 06)

This command is used to perform STOP, CLOSE, OPEN or ESD actions, or to update the position demand. In addition, the motion inhibit time, deadband and the minimum and maximum positions can also be programmed. The data is mapped as shown in table 8.

The deadband and motion inhibit time are both used when controlling the actuator via the position demand register. The deadband effects the positional accuracy in that it determines how close to the set point the actuator will travel before the motor is stopped. This aspect of position control must be borne in mind when attempting to open or close a valve, i.e. attempting to fully close an valve with a 0% position command will be subject the same deadband tolerance as any other position command. **To guarantee complete opening or closing of a valve a register write to the actuator control register must be used.**

Register Address	Function
0	Actuator control
1	Position demand
2	Deadband
3	Motion inhibit time
4	Minimum position
5	Maximum position

Table 8: Control Registers

Value	Function
00	STOP
01	CLOSE
02	OPEN
03	ESD

Table 9: Actuator Control Register

The actuator control register accepts one of four values to perform the actions shown in table 9;

Broadcast mode is supported by this command, however only the STOP and ESD commands will be actioned with OPEN and CLOSE commands being suppressed. On receipt of any of these commands the actuator will cancel positioning mode.

Note: Actuator control using this command to register 0 is different to the coil write command in that the outputs are not held active but are pulsed once only. This allows the operation to be cancelled by a Local Stop or Thermostat Trip for example.

As an example, to transmit a 50% set point to the positioner, the following command should be sent.

Address	Funct'n code	Start Pt Ho	Start Pt Lo	Data	Data	Check
11	06	00	01	80	00	CRC

Following receipt of a position set point, the actuator will enter positioning mode where it will remain until cancelled by using a force coil or pre-set control register command. The pre-set single register command is returned back to the host as the Modbus module reply.

7.2.7 Read Exception Status, (Function Code 07)

This command provides the facility of a short command to establish the status of the slave unit. The inputs listed in table 10 have been mapped into the single byte forming the reply.

Bit Number	Function
msb	S1
.	S2
.	S3
.	S4
.	Aux I/P 3 (MAINTAIN)
.	Aux I/P 2 (CLOSE)
.	Aux I/P 1 (OPEN)
lsb	Aux I/P 4 (ESD)

Table 10: Exception Status

The following is an example of an exception request to actuator address 17 followed by its reply;

Address	Function Code	Check
11	07	CRC

Address	Function Code	Coil data	Check
11	07	00	CRC

7.2.8 Loopback Test, (Function Code 08)

A number of tests are provided for verifying that the interface is working satisfactorily. These range in complexity from simple loopback tests to accessing a number of performance registers. Performance registers are initialised to zero on power up. All performance registers contain unsigned 16 bit integers.

The basic loopback test command is as follows;

Address	Funct'n code	Diag code Ho	Diag code Lo	Data	Data	Check
11	08	00	00	A5	37	CRC

Different diagnostic functions are selected by modifying the data in the diagnostic code field. The diagnostic codes supported are shown below in table 11;

Table 11: Loopback Test Codes

Diagnostic code (dec)	Function
00	Return query data
01	Restart communications
02	Return diagnostic reg
04	Force slave listen only
10	Clear diagnostic counts
11	Return bus message count
17	Return slave busy count

The Modbus module will keep diagnostic counts for Bus Messages and Slave Busy events. The diagnostic register contains bits indicating, watchdog recovery, EEPROM checksum fail, data logger communications time out, etc. as outlined in table 12 .

Table 12: Diagnostic register contents

Bit	Description
0	EEPROM timeout error
1	Checksum number 1 error
2	Checksum number 2 error
3	Checksum number 3 error, (control inhibit)
4	Watchdog recovery
5	Main board interface error
6	PWMCPT, (position feedback), error
7	PWMCCT, (torque feedback), error
8	Datalogger interface error
9	Remote I/O board interface error
10	Relay drive from Modbus module
11	Reserved
12	RS 485 highway ESD active
13	Auxiliary control I/P active
14	Positioner MIT active
15	Positioner enable flag

Comments;

Bits 0 to 7 generate the “error” bit in the digital status register.

Bit 0 - When set, indicates an EEPROM timeout has occurred.

Bit 1 - When set, indicates that a checksum error has occurred with the settings of the address, baud rate, stop bit or parity.

Bit 2 - When set, indicates that a checksum error has occurred with the settings of the motion inhibit time or deadband.

Bit 3 - When set, indicates that a checksum error has occurred with the settings one or more of the following; minimum and maximum position, the optional digital input settings, the action on loss of signal and its associated time delay. When set, this bit will also inhibit control of the actuator.

Bit 4 - This bit indicates whether the module has been reset after being powered on or has been reset by the watchdog.

Bit 5 - The main board interface error indicates a problem with SK6 or its associated loom.

Bit 6 - This bit is set when there is no position signal available from the position processor.

Bit 7 - This bit is set when there is no torque signal available from the torque processor.

Bit 8 - The datalogger interface error indicates a problem with SK8 or its associated loom.

Bit 9 - The Remote I/O board interface error indicates a problem with SK4, 5 or 7 or their associated looms.

Bit 10 - This bit indicates that the output relays R1 to R4 are being driven by the module.

Bit 12 - When set, this bit indicates that an ESD has been received via the RS485 highway.

Bit 13 - When set, this bit indicates that an auxiliary input, (enabled for control), is active.

Bit 14 - When set, this bit indicates that the MIT is active.

Bit 15 - When set, this bit indicates that the actuator is operating in positioning mode.

7.2.9 Force Multiple Coils, (Function Code 15)

This function provides a single command that allows the valve to OPEN, CLOSE, STOP or ESD as well as allowing relays 1 to 4 to be energised or de-energised. As with previous commands, the desired status of each coil is packed into the data field, one bit for each coil, (1 = ON, 0 = OFF). The coils are mapped as shown in table 13.

Coil Number	Function
0	Remote maintain
1	Remote close
2	Remote open
3	ESD / Thermostat bypass
4	Relay 1
5	Relay 2
6	Relay 3
7	Relay 4

Table 13: Coil Addresses

As an example, a STOP command to actuator 17 can be generated by ensuring that the remote open, close, maintain and ESD inputs are OFF. This can be achieved with the following command;

Address	Funct'n code	Address Ho	Address Lo	Quantity	Quantity	Byte count	Data	Check
11	0F	00	00	00	04	01	00	CRC

The resulting reply will be of the format below, (note that the byte count and data are not echoed back);

Address	Funct'n code	Address Ho	Address Lo	Quantity	Quantity	Check
11	0F	00	00	00	04	CRC

7.2.10 Pre-set Multiple Registers, (Function Code 16)

This command is used for actuator control and for downloading configuration information. Currently only the parameters specified in table 14 are available, limiting the maximum number of registers to 6.

Register Address	Function
0	Actuator control
1	Position demand
2	Deadband
3	Motion inhibit time
4	Minimum position
5	Maximum position

Table 14: Control Registers

For example, the command to pre-set the position demand and deadband simultaneously in actuator 17 would be;

Addr	Funct code	Addr Ho	Addr Lo	Qty	Qty	Byte cnt	Data Ho	Data Lo	Data Ho	Data Lo	Check
11	10	00	01	00	02	04	FF	FF	0C	CC	CRC
								Position		Deadband	

The above command would set the demand to 100% and the deadband to 5%. The reply would be the same as the message but with the byte count and data fields omitted, e.g.;

Addr	Funct code	Addr Ho	Addr Lo	Qty	Qty	Check
11	10	00	01	00	02	CRC

7.2.11 Report Slave ID, (Function Code 17)

Report Slave ID permits the user to obtain information that identifies the type of Modbus slave and its issue level. The command for extracting this information, (from actuator 17), is as follows;

Addr	Funct code	Check
11	11	CRC

The reply would have the following format;

Addr	Funct code	Byte count	Slave ID	Run Light	Device Dependent	Check
11	11	42	00	00	48 Bytes	CRC

As the interface does not support a Run light, this byte will always be returned as 00 as will Slave ID.

The format of the 48 bytes is as follows;

- Bytes 1 - 26 - Identifier, e.g. Rotork IQ MODBUS MODULE.
- Bytes 27 - 48 - Software Version: MXXX (where XXX = revision level)

7.2.12 Exception Reporting

If the Modbus module detects an error such that the message cannot be correctly decoded, e.g. a CRC error exists, no reply is produced. If the slave is able to correctly decode the message but for example does not support the requested operation or the data is outside allowable limits, an exception message is generated. A list of the exception response codes are shown in table 15.

Code	Meaning
01	Illegal function
02	Illegal data address
03	Illegal data value
04	Failure in associated device
06	Busy, rejected message

Table 15: Exception Codes

The format of the exception report is as follows;

Addr	Funct code	Exception code	Check
	8 - bits	8 - bits	CRC

Code 04 will be produced if an attempt is made to access the data logger memory when no device is fitted.
Code 06 can occur when processing long transactions, such as accessing the data logger and another request is transmitted before processing is complete.

7.2.13 Data Offsets

Many Modbus hosts introduce offsets into the variable map dependent upon the function code. Where this is the case, offsets have to be added to the addresses specified under sections 7.2.1 to 7.2.12. Typical offsets are as shown in table 16.

Code	Offset
01	1
02	10001
03	40001
04	30001
05	1
06	40001
15	1
16	40001

Table 16: Modbus Data Offsets

7.2.14 Broadcast Messages

Within the Modbus protocol specification, only function codes 5, 6, 8, 15 and 16 are recognised as valid for broadcast. In order to minimise the possibility of erroneous actuator operation, further restrictions have been added within the Modbus Module software such that only an ESD operation or a STOP, using function code 5 or 6, are valid broadcast messages, i.e. OPEN and CLOSED are disabled. Global commands to relays 1 to 4 and to the other registers are permitted.

8. SETTING UP A MODBUS MODULE

The parameters that determine the actions and settings of the Module may be programmed by a variety of tools. All Module variable parameters have default settings that will be present on a new Module. These will generally require some alterations so as to match the Module to the actuator and to the system.

BEFORE SETTING ANY VARIABLES ENSURE THAT THE ACTUATOR AND PLANT IS IN A SAFE CONDITION. SETTING SHOULD ONLY BE CARRIED OUT BY A COMPETENT ENGINEER.

The tools that may be used to set the parameters are:

- IQ Setting Tool - limited number of parameters
- IQ Communicator
- A Host system via the RS485 port - limited number of parameters

In all cases the data variables are stored in EEPROM. Table 17 shows the identity of each variable parameter and its default setting together with the tool that can be used to vary the setting.

Table 17 - Parameters, Defaults and Tools

PARAMETER IDENTITY	PERMITTED VALUES	SET BY	DEFAULT
Comms Baud Rate	110, 300, 600, 1200, 2400, 4800, 9600, 19200, 38400	S, C	9600
Module Address	1 -247	S, C	247
Auxiliary mask	XXXX YYYY (00 - FF hex)	S, C, P	0000 1111, (0F hex)
Position Minimum	0% - 100%	S, C, P	0% (1% resolution)
Position Maximum	0% - 100%	S, C, P	100% (1% resolution)
Motion Inhibit Timer	0 - 99 seconds	S, C, P	5 sec. (1 s. resolution)
Deadband	0% - 25.5%	S, C, P	5% (0.1% resolution)
Parity	Odd, Even or None	C	None
Stop Bits	1 or 2	C	1
Action on loss of RS485 signal	Open / Close / Stay put / Off	S, C	Off
Time delay for action on loss of signal	0 - 255 seconds	C	255 sec

Key: S = IQ Setting Tool, C = IQ Communicator, P = PLC Via RS485 highway

N.B. To use the setting tool the actuator must be in "Local"

Communication Baud Rate

Must be set to 110, 300, 600, 1200, 2400, 4800, 9600, 19200 or 38400 baud. All the Modules on the RS485 highway must be set to the same baud rate.

Module Address

Must be set in the range 1-247. On a single 2 / 4 wire highway each Module must have a unique address. The order of the addresses on the data highway need not be consecutive.

Remote Auxiliary Input Mask

Must be set for the desired function of the Remote Input board, (if fitted). If there are no Remote Auxiliary inputs then the default setting may be left in place.

The 8 data bits in the mask relate to the function and contact sense of the inputs.

The 4 most significant bits relate to the use of the inputs for actuator control, if a '1' is put in the mask in the appropriate position the that input is enabled as an actuator control input, if a '0' is placed in the mask then the input becomes a reported signal only.

The 4 least significant bits relate to the sense of the input. A '1' placed in the appropriate bit makes a contact closure achieve the action or be reported as a '1' on the data communications. A '0' placed in the bit inverts the signal and makes a contact opening achieve the action or be reported as a '1', (see table 18).

Table 18 Remote Auxiliary Mask Settings

AUX 1	Bit 0	0	Report closed contact input as '0', action as control input if enabled
		1	Report closed contact input as '1', action as control input if enabled
AUX 2	Bit 1	0	Report closed contact input as '0', action as control input if enabled
		1	Report closed contact input as '1', action as control input if enabled
AUX 3	Bit 2	0	Report closed contact input as '0', action as control input if enabled
		1	Report closed contact input as '1', action as control input if enabled
AUX 4	Bit 3	0	Report closed contact input as '0', action as control input if enabled
		1	Report closed contact input as '1', action as control input if enabled
AUX 1	Bit 4	0	Disable AUX 1 as 'OPEN' command
		1	Enable AUX 1 as 'OPEN' command
AUX 2	Bit 5	0	Disable AUX 2 as 'CLOSE' command
		1	Enable AUX 2 as 'CLOSE' command
AUX 3	Bit 6	0	Disable AUX 3 as 'STOP/MAINTAIN' input, all remote inputs always push to run mode
		1	Enable AUX 3 as 'STOP/MAINTAIN' command
AUX 4	Bit 7	0	Disable AUX 4 as 'ESD' command
		1	Enable AUX 4 as 'ESD' command

The auxiliary input mask takes the form as shown in table 19:

	MSB				LSB			
	Bit 7	Bit 6	Bit 5	Bit 4	Bit 3	Bit 2	Bit 1	Bit 0
	Enable AUX 4 (ESD)	Enable AUX 3 (Stop/ Maintain)	Enable AUX 2 (CLOSE)	Enable AUX 1 (OPEN)	Invert AUX 4	Invert AUX 3	Invert AUX 2	Invert AUX 1
Example 1	1	1	0	0	0	1	X	X
Example 2	1	0	1	1	0	X	1	1
Example 3	1	0	1	1	1	1	1	1

Table 19: Auxiliary Mask Examples

Key: Enable = 1 to enable the input as a Remote Control Input.
 Invert = 1 for a normally open input contact to achieve this action.

Example 1: Remote auxiliary control ESD input contact, opening to cause an ESD, with the actuator set to be push to run, (no connection need be made to the AUX 3, (Stop/Maintain), input).

Example 2: Remote auxiliary control ESD input contact input, opening to cause ESD, remote Open and Close inputs where a closing contact causes the actuator motion, all motion to be “push to run” mode.

Example 3: Remote auxiliary control ESD input contact, closing to cause ESD, remote Open and Close inputs where a closing contact causes the actuator motion, all motion in “push to run” mode, AUX 3 input utilized for a contact input that reports its state over the RS485 highway, when the AUX 3 contact is closed a ‘1’ is reported.

0% and 100% Positions - Limited Range Position Reporting

Where the analogue Valve Position data is to be reported over only part of the total valve stroke the settings for minimum and maximum position have to be made. The 0% position is that point in the stroke where the analogue data will report 0%, the 100% position is where it will report 100%. Between these two settings the position reported is a proportion of the travel between these two positions.

Where the position is to be reported over the full valve stroke of a forward acting valve, then these settings should be 0% when the valve is closed and 100% when it is open. [If the valve is reverse acting then 0% will be where the valve is fully open.]

Motion Inhibit Timer

To protect the actuator motor the setting for the Motion Inhibit Timer is designed to prevent the motor exceeding the rated number of starts per hour. If the motor is rated at 60 starts per hour the setting should be 60 seconds [this assumes that the motor running periods will be very short].

Deadband

The Deadband setting will prevent the actuator from overrunning. The deadband must be set to a number that provides good close control with the minimum of actuator starts. Ideally the actuator should never be prevented from starting by the motion inhibit timer. The actual setting for the deadband will depend on the actuator and valve combination. If the control has to be exact then a small (2%) deadband should be set, if a more tolerant control is permitted then a deadband of 5% is reasonable, (see section 8.4.3).

Action on loss of RS485 signal

This determines what the actuator will do if no Modbus messages are sent to the Module for the time specified in “Time delay for action on loss of signal”. The Module’s outputs are not changed if the “Action” is switched off

Parity

Parity is a simple method used to check for data corruption within each byte of data sent. When parity is selected it is added to each byte of data before being transmitted and checked and removed after being received. If odd parity is selected, the number of logic level 1’s are counted and if equal to an even number a “1” is put into the parity bit space by the transmitter. If an odd number of logic level 1’s are counted a “0” is put into the parity bit space. The reverse is true for even parity. All devices on the RS485 highway must be set to the same parity.

Stop Bits

Stop bits are used to define the end of the message byte. All devices on the RS485 highway must be set to the same number of stop bits.

8.1 Using an IQ Setting Tool

The IQ Setting Tool accesses the Module via the infra-red data link. The actuator must be powered on before any major variables can be changed. The Setting Tool menus list the methods for accessing the parameters in the Module that can be changed, in order to access these menus the option must be set 'on' [OP]. If the Setting Tool is being used for adjusting position control data then the Folomatic menu option must also be set 'on' [OF]. Full details are included in the Setting Tool manual.

8.2 Using an IQ Communicator

The IQ Communicator accesses the Module via the infra-red data link. It is recommended that the settings are not changed whilst the actuator is in use. Full details of the use of the Communicator for setting the Modbus Module variables are included in the Communicator manual.

9.0 PROGRAMMING A MODBUS MODULE

This section outlines the steps needed to programme the parameters listed below using an IQ Setting Tool. Note that the Setting Tool can only be used to programme the Module when the actuator selector knob is set to the local position. To change any of the following parameters it is essential for the actuator to be in “setting mode” rather than “viewing mode”.

(For further information on setting up an IQ actuator see the IQ Installation Instructions Manual E170E).

- Baud Rate
- Address
- Auxiliary Input Mask - (available only when a remote board is fitted).
- Minimum Position
- Maximum Position
- Motion Inhibit Timer
- MIT Deadband
- Action on loss of RS485 signal

The above options are all available via the “secondary function settings” within the setting tool options menus.

(Note, with a dual redundant configuration the setting tool is only able to communicate to the Module set to “A”. To communicate to the “B” Module a Communicator has to be used).

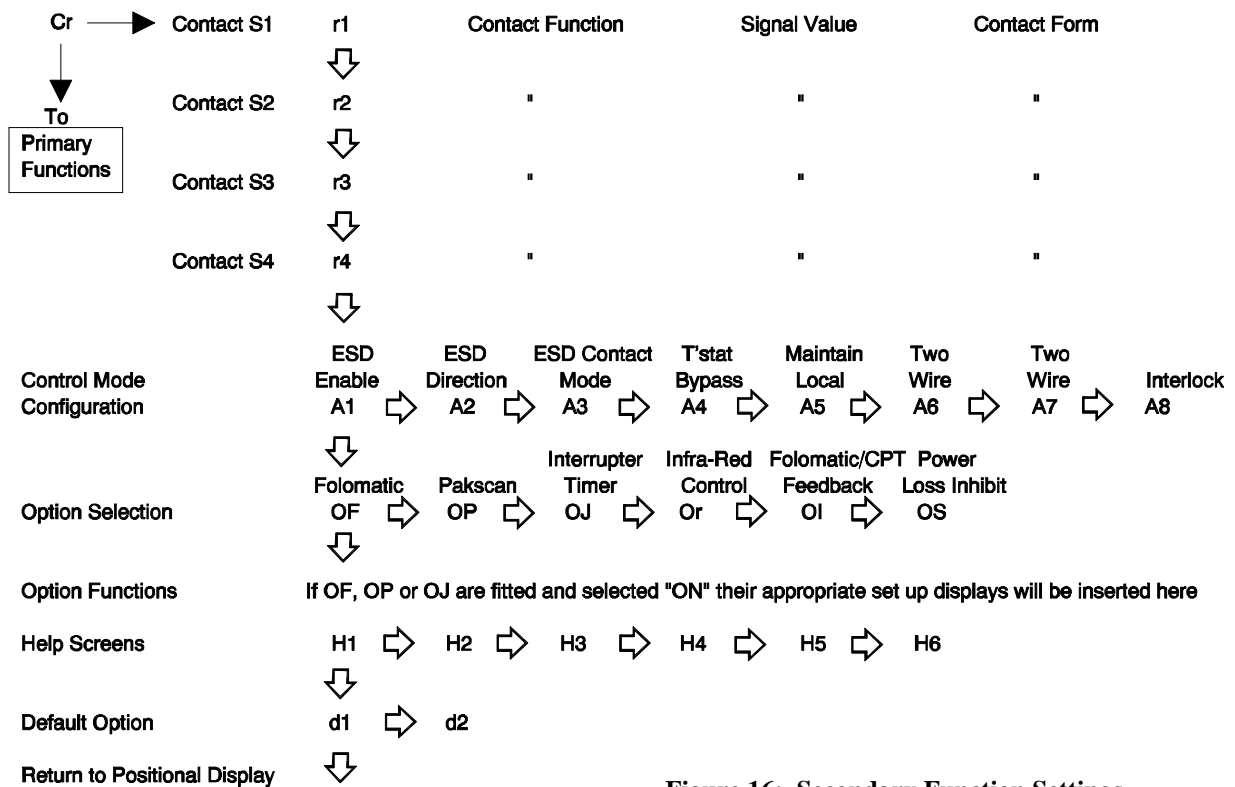

Figure 16: Secondary Function Settings

Baud Rate / Address / Auxiliary Mask

These options are all programmable via the Pakscan option menu, but the baud rate and address can only be changed when there is no signal on the RS485 highway. Using the menu on page 46 select the Pakscan option [OP], and set it to “[on]”.

Address change

The address is able to be changed in the [PA] screen which is reached by pressing the down arrow. Using the “+” and “-” keys allows the address to be changed. Once the correct address has been selected, press enter. The display will blink to confirm that it has received and accepted the new setting.

Baud rate change

The baud rate is able to be changed in the [PB] screen which is reached by pressing the across arrow . Using the “+” and “-” keys allows the baud rate to be changed. Once the correct baud rate has been selected, press enter. The display will blink to confirm that it has received and accepted the new setting.

Auxiliary input mask change

The auxiliary input mask is able to be changed in the [PF] screen which is reached by pressing the across arrow . Using the “+” and “-” keys allows the mask to be changed. Once the correct mask has been selected, press enter. The display will blink to confirm that it has received and accepted the new setting.

Figure 17: Setting Menus for baud rate, address and auxiliary mask [OP]
[ON]

down arrow

[PA]	across	[PB]	across	[PF]
[01]	arrow	[96]	arrow	[FF]

Minimum Position / Maximum Position / Motion Inhibit Timer / MIT Deadband / Action on loss of RS485 signal

These options are all programmable via the Folomatic option menu. Using the menu on page 46 select the Folomatic option [OF] and set it to “[on]”.

The first item that needs to be checked is the folomatic feedback setting. Press the across arrow until the [01] screen is reached. The display should be set to [HI], indicating that 0% is displayed as 0% and 100% is displayed as 100%. (If the display is set to [LO] the Modbus positioning function will not operate).

Minimum position change

Press the down arrow to reach the Folomatic set up displays and then the across arrow until the [FL] screen is reached. This allows the minimum position to be entered, “[] []” = valve closed, “[= =]” = valve open and “[01]” to “[99]” = percent open. Select the correct value and press enter, the display will blink to confirm that it has received and accepted the new setting.

Maximum position change

Press the across arrow once and the [FH] screen will appear. This allows the maximum position to be entered, (similar to the minimum position above). Select the correct value and press enter, the display will blink to confirm that it has received and accepted the new setting.

MIT deadband change

Press the across arrow once and the [fd] screen will appear. Use the “+” or “-” key to select the deadband from 00 to FF, corresponding to 0% to 25.5% of setpoint signal. Select the correct value and press enter, the display will blink to confirm that it has received and accepted the new setting.

MIT change

Press the across arrow once and the [ft] screen will appear. Use the “+” or “-” key to select the deadband from 00 to 99, corresponding to 0 to 99 seconds. Select the correct value and press enter, the display will blink to confirm that it has received and accepted the new setting.

Action on loss of RS485 signal

There are two screens to be checked when setting this function. Press the across arrow once and the [FA] screen will appear. If the actuator is to go to a set position or to stay put on detection of a loss of RS485 signal, set the value to [on] using the + or - key. If a loss of signal is to have no effect on the the actuator then the option [of] should be selected, using the + or - key. Once the correct value has been chosen press enter and the display will blink to confirm that it has received and accepted the new setting.

If [on] has been chosen, press the across arrow once and the [ff] screen will appear. Using the + or - key select either [lo], which will send the actuator to the 0% set point, or [sp] which will cause the actuator to stop where it is, or [hi] which will cause the actuator to move to the 100% position. Once the correct value has been chosen press enter and the display will blink to confirm that it has received and accepted the new setting.

Figure 18: Setting Menus for Minimum Position, Maximum Position, Motion Inhibit Timer, MIT Deadband and Action on loss of RS485 signal

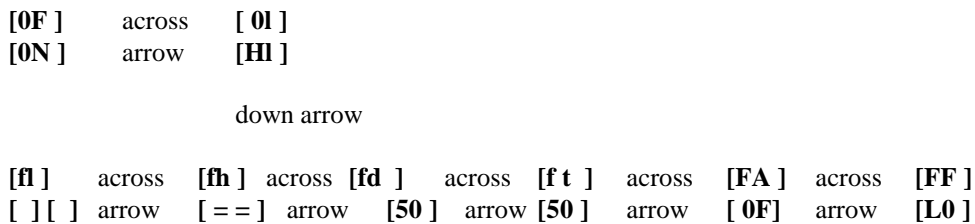

10. MAINTENANCE AND REPAIR

There is no periodic service requirement for the Module.

Repairs should not be attempted on the Module. Any failure should be rectified by replacing the Module with new compatible device. Static sensitive and CMOS devices are used in the Module. It is therefore mandatory to observe anti-static precautions when handling or working on a Module.

The Module may be stored for a period of up to 10 years in clean conditions.

11. RECORDS

The following information should be recorded for each Module (M = Major Parameter) :

	Valve Tag	
	Actuator Serial Number	
M	Modbus Module Address	
M	Baud Rate	
	Parity Bit	
	Stop Bits	
	Motion Inhibit Timer	
	Deadband	
	Auxiliary Mask Setting	
	0% Limited Position Setting (% of full stroke)	
	100% Limited Position Setting (% of full stroke)	
	External Interlocking	ON / OFF
	Action on loss off signal	
	Time delay for action on loss of signal	

APPENDIX PARAMETER ACCESS TABLE

Digital Output Status

- PLC read - Function Code 1**
- PLC single write - Function Code 5**
- PLC multiple write - Function Code 15**

Coil Address	Parameter description	Setting	Communicat	PLC
0	Remote maintain	-	R	R
1	Remote close	-	R	R
2	Remote open	-	R	R
3	ESD / Thermostat bypass	-	R	R
4	Relay 1	-	R/W	R/W
5	Relay 2	-	R/W	R/W
6	Relay 3	-	R/W	R/W
7	Relay 4	-	R/W	R/W

Key; R = Read, W = Write

Note:

- 1/ Relays 1 to 4 are only available when the remote input PCB is fitted**
- 2/ Writing to relays 1 to 4 is only possible when SK5 and SK7 are connected to SK2 on the remote input PCB**

Digital Input Status

PLC read - Function Code 2

Bit Address	Parameter description	Setting	Communicato	PLC
0	Centre column moving	R	R	R
1	Close limit switch	R	R	R
2	Open limit switch	R	R	R
3	Thermostat tripped	R	R	R
4	Monitor relay	R	R	R
5	Local selected	R	R	R
6	Remote selected	R	R	R
7	Battery low	R	R	R
8	Clockwise contactor on	R	R	R
9	Anti-clockwise contactor on	R	R	R
10	Interrupter timer	R	R	R
11	MIT active	-	R	R
12	Open interlock	R	R	R
13	Close interlock	R	R	R
14	Position control enabled	-	R	R
15	Error	-	R	R
16	S1	R	R	R
17	S2	R	R	R
18	S3	R	R	R
19	S4	R	R	R
20	Aux Input 3 (remote maintain)	-	R	R
21	Aux Input 2 (remote close)	-	R	R
22	Aux Input 1 (remote open)	-	R	R
23	Aux Input 4 (remote ESD)	-	R	R

Key: R = Read

Note:

- 1/ Bits 16 to 23 are only valid when a remote module PCB is fitted to the actuator
- 2/ The setting tool can only be used when the actuator is in “Local” and the setting tool information is available via the help screens

Output Registers

- PLC read - Function Code 3
- PLC single write - Function Code 6
- PLC multiple write - Function Code 16

Reg Address	Parameter description	Range (Hex)	Value	Default	Setting Tool	Communicator	PLC
0	Actuator control	00 - 03	0 - 3	-	-	R	R/W
1	Position demand, (desired value)	0000 - FFFF	0 - 100%	-	-	R/W	R/W
2	Deadband	0000 - 4147	0 - 25.5%	5%	R/W	R/W	R/W
3	Motion inhibit time	0000 - 00FF	0 - 255 sec	5 sec	R/W	R/W	R/W
4	Minimum position	0000 - FFFF	0 - 100%	0%	R/W	R/W	R/W
5	Maximum position	0000 - FFFF	0 - 100%	100%	R/W	R/W	R/W

Key; R = Read, W = Write

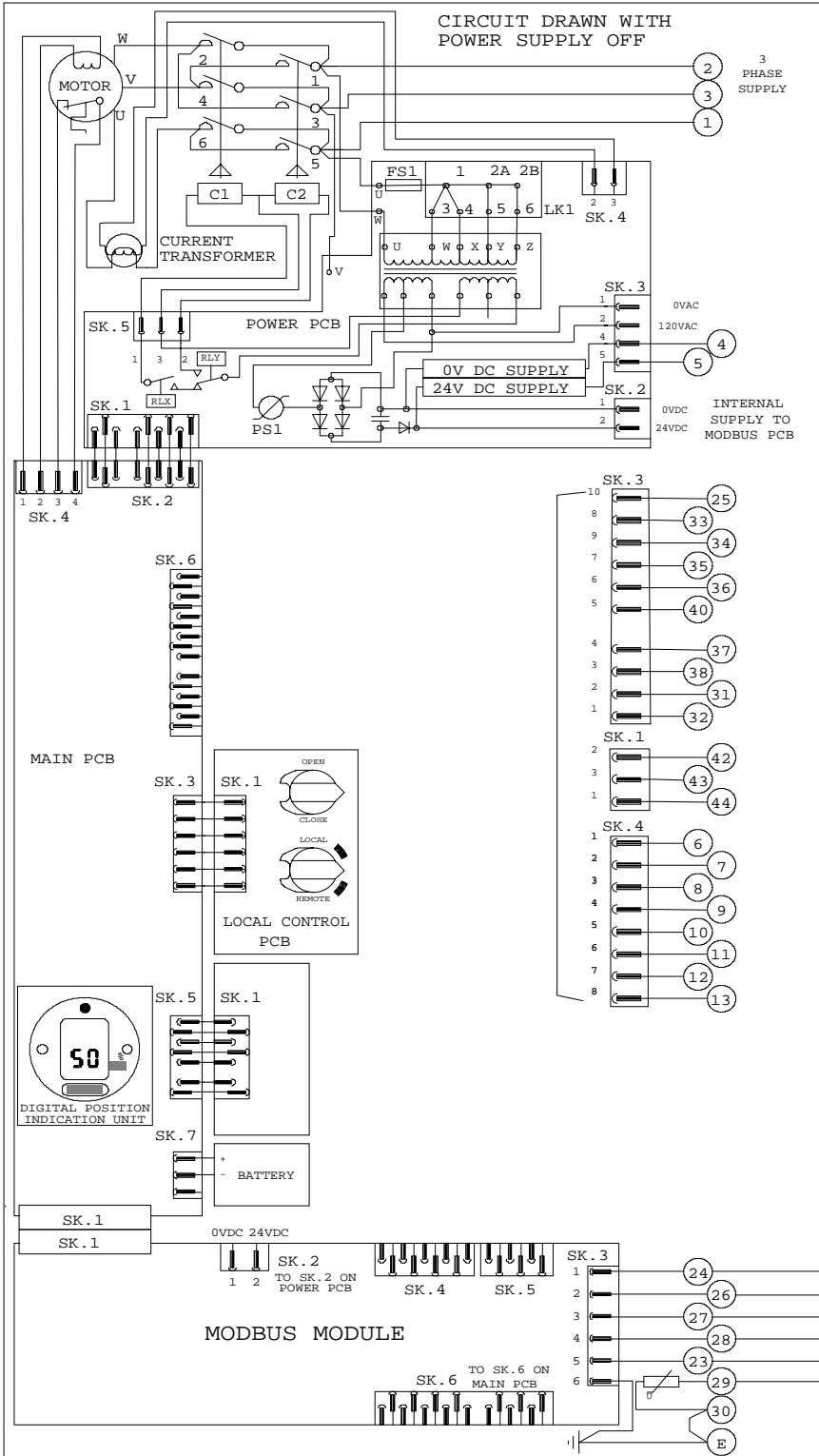

CIRCUIT DIAGRAM No -REV 10
200-500-04
 C E D F

TRANSFORMER TAPPING OPTIONS

TYPE 1

TAP	NOM 50/60HZ	50HZ	60HZ
W	220/230	176-242	198-259
X	380/400	304-418	342-446
Y	415/420	332-457	374-487
Z	440/460	352-484	396-517

FUSE FS1 - 250mA ANTI-SURGE

TYPE 2

TAP	NOM 50/60HZ	50HZ	60HZ
W	346/380	285-388	321-419
X	480/500	406-552	432-564
Y	240/240	192-261	216-282
Z*	550/575	445-605	501-654

FUSE FS1 - 250mA ANTI-SURGE
 * 150mA ANTI-SURGE

TYPE 3

TAP	NOM 50/60HZ	50HZ	60HZ
X	660/660-690	534-726	600-726
Y	690/___	558-759	

FUSE FS1 - 150mA ANTI-SURGE
 ALL TRANSFORMER TYPES - PS1 SELF RESETTING FUSE

NOTE
 WHERE CUSTOMERS WISH TO HAVE THE THERMOSTAT BY-PASSED DURING EMERGENCY SHUTDOWN OPERATION, IT SHOULD BE NOTED THAT ANY ACTUATOR HAZARDOUS ENCLOSURE CERTIFICATION WILL BE INVALIDATED WHILE THE THERMOSTAT IS BY-PASSED.

MAX EXTERNAL LOAD ON TERMINALS 4 & 5 TO BE 5W.
 WIRES ARE IDENTIFIED AT EACH END BY TERMINAL NO. OR TAG No.
 ALL SOCKET CONNECTIONS BETWEEN PCB'S ARE WIRED PIN 1 TO PIN 1 etc.

MODBUS ONLY
 CARE SHOULD BE TAKEN TO ENSURE THAT CIRCUITS CONNECTED TO TERMINALS 4 OR 5 ARE NOT CONNECTED DIRECTLY OR INDIRECTLY TO GROUND.

No	DATE	REVISION
04	280396 PJW	MODBUS NOTE ADDED Checked K.S 280396

rotork

ROTORK CONTROLS LTD
 BATH, ENGLAND
 BA1 3JQ
 (Phone 01225-733200)

ROTORK CONTROLS INC
 ROCHESTER, NY 14624
 tel (716) 328-1550

CONFIG BY PJW
 DATE 120695
 CHECKED SC
 BASE WD 200-500
 JOB No --

**IQ + MODBUS MODULE
 NO REMOTE INPUTS**

CIRCUIT DIAGRAM No -REV 10
200-500-04
 C E D F

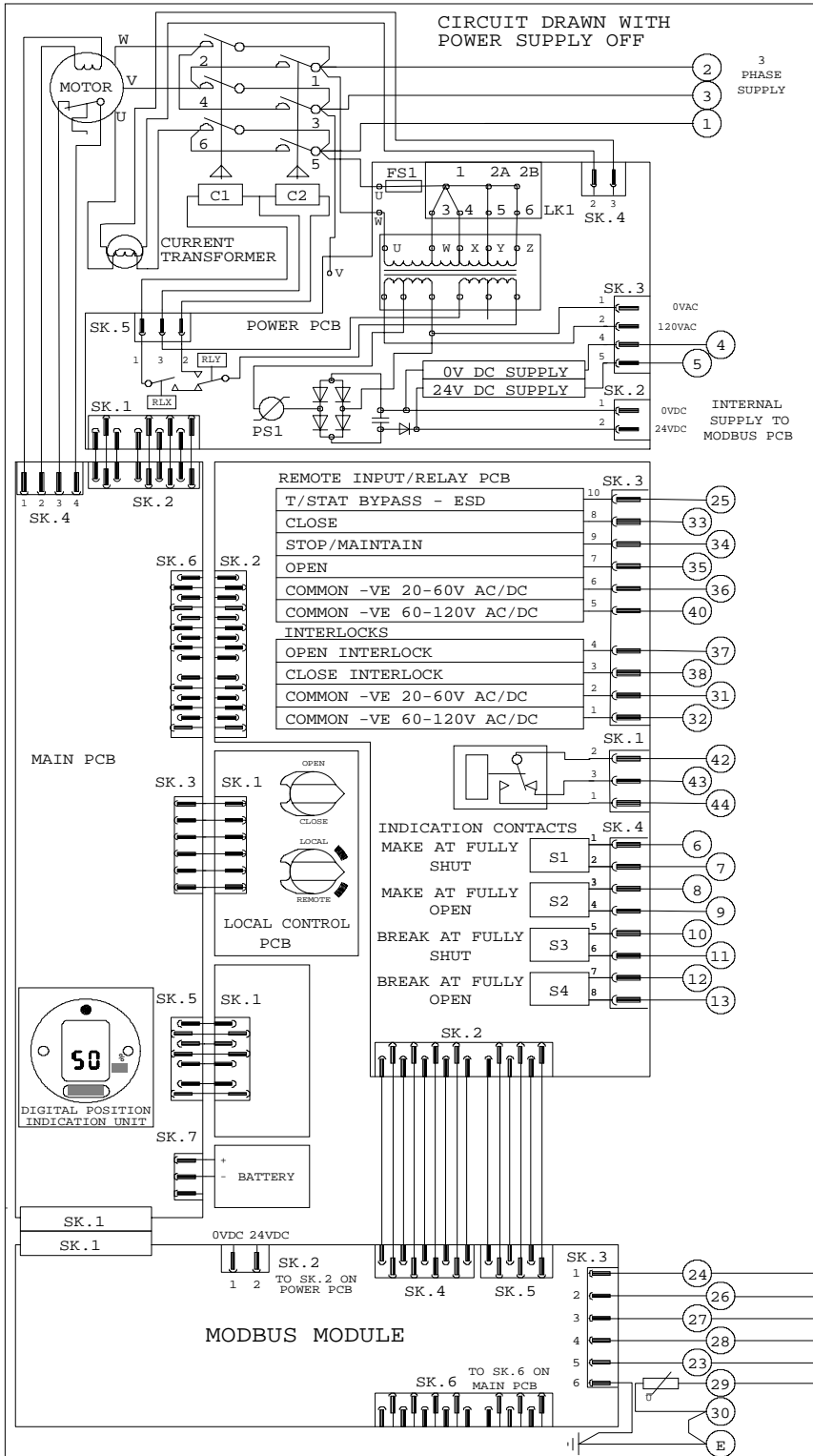

CIRCUIT DIAGRAM No -REV 10
200-400-03
C E D F

TRANSFORMER TAPPING OPTIONS

TYPE 1

TAP	NOM 50/60HZ	50HZ	60HZ
W	220/230	176-242	198-259
X	380/400	304-418	342-446
Y	415/420	332-457	374-487
Z	440/460	352-484	396-517

FUSE FS1 - 250mA ANTI-SURGE

TYPE 2

TAP	NOM 50/60HZ	50HZ	60HZ
W	346/380	285-388	321-419
X	480/500	406-552	432-564
Y	240/240	192-261	216-282
Z*	550/575	445-605	501-654

FUSE FS1 - 250mA ANTI-SURGE

* 150mA ANTI-SURGE

TYPE 3

TAP	NOM 50/60HZ	50HZ	60HZ
X	660/660-690	534-726	600-726
Y	690/___	558-759	

FUSE FS1 - 150mA ANTI-SURGE

ALL TRANSFORMER TYPES - PS1 SELF
RESETTING
FUSE

NOTE

WHERE CUSTOMERS WISH TO HAVE THE THERMOSTAT BY-PASSED DURING EMERGENCY SHUTDOWN OPERATION, IT SHOULD BE NOTED THAT ANY ACTUATOR HAZARDOUS ENCLOSURE CERTIFICATION WILL BE INVALIDATED WHILE THE THERMOSTAT IS BY-PASSED.

MAX EXTERNAL LOAD ON TERMINALS 4 & 5 TO BE 5W.

FOR TYPICAL REMOTE CONTROL INDICATING, MONITORING AND ALARM CIRCUITS SEE PUBLICATION E120E

CONTROL SIGNAL THRESHOLD VOLTAGES TO BE MINIMUM 'ON' 20V AC/DC
MAXIMUM 'OFF' = 3V
MINIMUM CONTROL SIGNAL DURATION TO BE 300ms.

CURRENT DRAWN FROM EACH REMOTE CONTROL SIGNAL IS 5mA ON 24V DC

WIRES ARE IDENTIFIED AT EACH END BY TERMINAL No. OR TAG No.

ALL SOCKET CONNECTIONS BETWEEN PCB'S ARE WIRED PIN 1 TO PIN 1 etc.

- 24 FIELD CONNECTION '1A'
- 26 FIELD CONNECTION '1B'
- 27 FIELD CONNECTION '2A'
- 28 FIELD CONNECTION '2B'
- 23 COMMON
- 29 SCREEN

No	DATE	REVISION
03	050296 PJW	THERMOSTAT BYPASS NOTE ADDED. Checked K.S 050296 EC0246



ROTORK CONTROLS LTD
BATH, ENGLAND
BA1 3JQ
(Phone 01225-733200)

ROTORK CONTROLS INC
ROCHESTER, NY 14624
tel (716) 328-1550

CONFIG BY PJW
DATE 120695
CHECKED SC
BASE WD 200-400
JOB No --

IQ + MODBUS MODULE

CIRCUIT DIAGRAM No -REV 10
200-400-03
C E D F

Rotork Controls Ltd
Bath, England
BA1 3JQ
tel: (01225) 733200
fax: (01225) 333467
e-mail: info@rotork.co.uk
Web site: <http://www.rotork.com>

Rotork Controls Inc
675 Mile Crossing Blvd,
Rochester
New York 14624
USA
tel: (716) 328 1550
fax: (716) 328 5848
e-mail: info@rotork.com