

rotork®

Keeping the World Flowing
for Future Generations

Modbus Actuator Control



Modbus®

Serial communication and control of Rotork actuators

Contents

Section	Page
Introduction	3
Modbus Overview	4
Modbus Features	5
Modbus Module	5
RS-485 Communication Highway	5
Rotork Modbus Module Formats	6
Modbus RTU	6
Modbus Commands	6
Dual Channel Module	7
Single Channel plus Repeater Module	7
Control and Feedback	8
Valve Torque Profile Data	10
Function Code Support	10
Configuration	10
Lightning Protection	11
Modbus Technical Data	11



Rotork is the global market leader in valve automation and flow control. Our products and services are helping organisations around the world to improve efficiency, assure safety and protect the environment.

We strive always for technical excellence, innovation and the highest quality standards in everything we do. As a result, our people and products remain at the forefront of flow control technology.

Uncompromising reliability is a feature of our entire product range, from our flagship electric actuator range through to our pneumatic, hydraulic and electro-hydraulic actuators, as well as instruments, gearboxes and valve accessories.

Rotork is committed to providing first class support to each client throughout the whole life of their plant, from initial site surveys to installation, maintenance, audits and repair. From our network of national and international offices, our engineers work around the clock to maintain our position of trust.

Keeping the World Flowing for Future Generations

Introduction

Direct Modbus control of Rotork actuators by 2-wire RS-485 serial communications provides a simple and reliable control strategy for valve automation.

Rotork electric actuators may be controlled over the low cost RS-485 network using the Modbus RTU protocol when they are fitted with the Rotork Modbus option module.

The inherent flexibility of the Modbus RTU protocol allows the systems engineer to control the data flow on the highway as well as the registers read and written to. There are no complications with device description files or special tools needed to set up a Modbus system. The PLC and DCS drivers are all simple and easy to use.



Modbus®

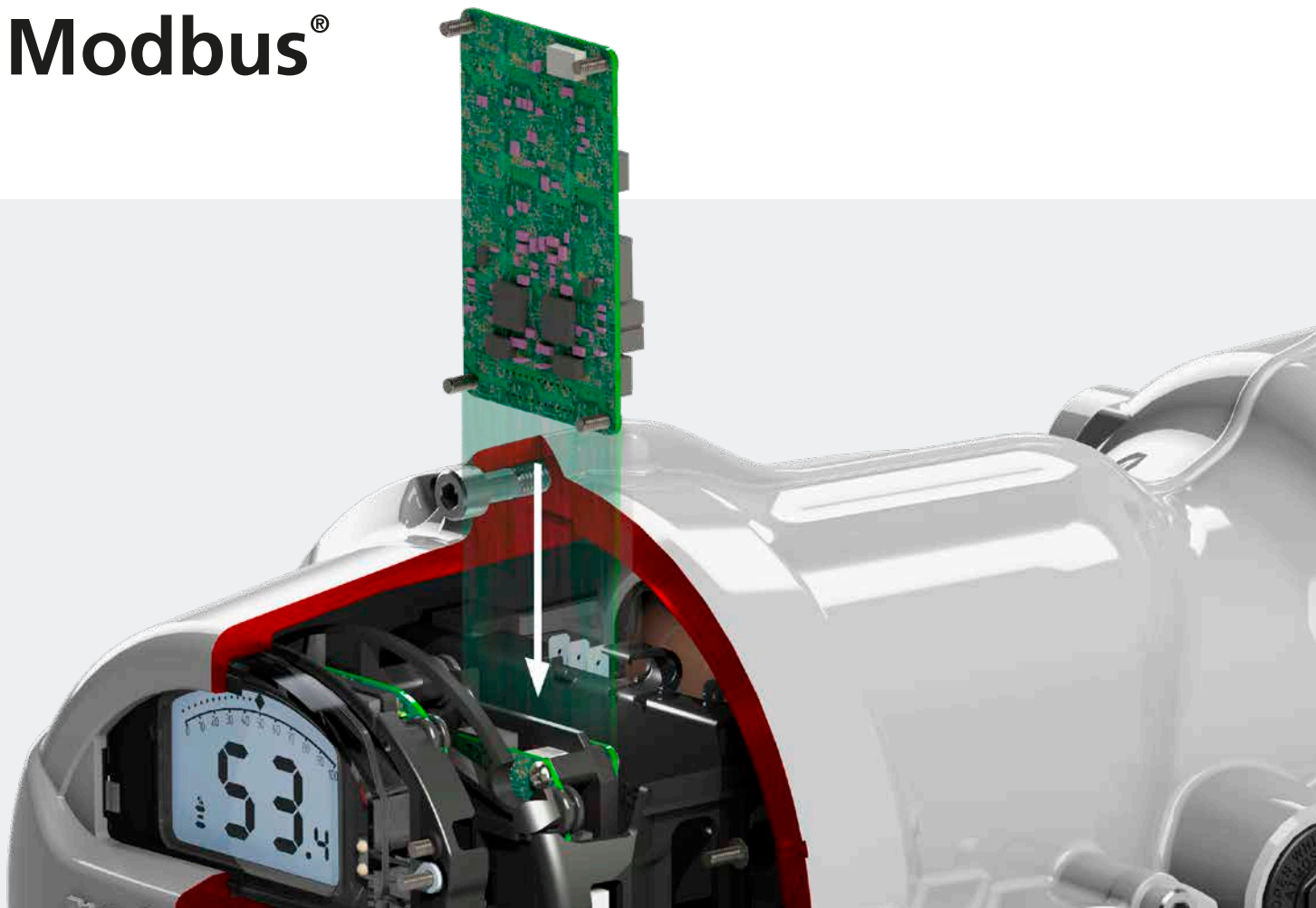

Modbus Overview

Modbus is the most popular communication protocol in use today. It has the widest acceptance and highest number of applied systems of any automation protocol.

- International Open Standard
- Highly reliable standardised communications
- Simple connectivity, easy configuration

Rotork Modbus module:

- Compatible with all IQ, CK, IQT, SI/EH, CMA, CVA, ROMpak, Q and K range actuators
- RS-485, RTU communication
- Low installation and maintenance costs
- High control system flexibility
- Data transfer between 300 and 115 kbaud
- Simple plant expansion
- Cabling requires 2 wires only per channel provided the ground potentials are equal
- Three versions available: Single Channel, with and without repeater and Dual Channel

For more information on Modbus® consult the web site at <http://www.Modbus.org>. Modbus was developed by Modicon in the 1980s and remains one of the leading protocols used in the field of process control and automation.

Modbus®



Modbus Features

Modbus Module

The Modbus module is fitted inside the actuator electrical housing and interfaces directly with the actuator electronics. Once fitted, all the normal commands associated with moving the actuator together with feedback and some historical data become available on the Modbus RS-485 highway.

There are a number of user settings to be made for the system variables and actuator performance, such as the baud rate and the slave address of the actuator. These are set by either using the infrared or Bluetooth communication link to the actuator, or by writing over the network to the appropriate registers in the module.

All the settings are held in non-volatile EEPROM memory on the card.



RS-485 Communication Highway

The Modbus module is a slave device and it uses 2-wire, half duplex, RTU communications on the balanced RS-485 highway. An additional connection is provided at each actuator for a 'common' wire linking all the actuators together.

The RS-485 standard requires the common mode differential voltage between all the points on the highway to be less than 7 Volts. If the site wide common mode voltage is above this level, the additional connection to a third wire should be made to ensure successful field communication.

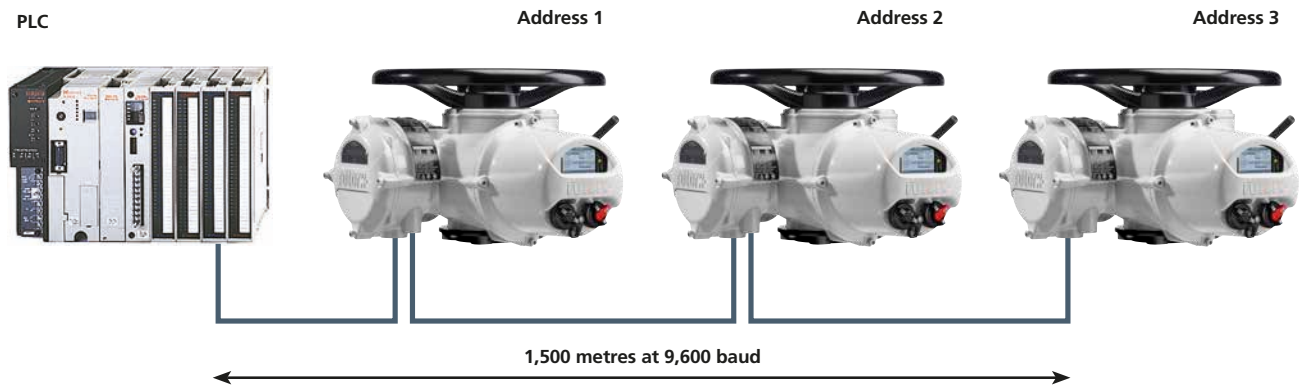

Data Rate (baud)	300	600	1k2	2k4	4k8	9k6	19k2	38k4	57k6	115k2
Maximum Cable Length	24 km	12 km	12 km	6 km	3 km	1.5 km	1.2 km	1.0 km	750 m	500 m
Total Spur Length	2 km	1 km	1 km	500 m	500 m	500 m	500 m	300 m	200 m	100 m

Note: Each actuator includes up to 0.6 m of cable spur. Calculations based on Belden 8770 cable parameters, 18 AWG, 1 mm² cross section, 3 cores.

Modbus Features

Rotork Modbus Module Formats

The Rotork Modbus Module is available in three forms for different applications.

The Single Channel card is the simplest of the three with only one highway connection.

The Dual Channel card has two independent communication channels and is usually connected to two highways with redundant communication paths. This increases the plant availability by reducing the probability of communication failure preventing the actuator from being controlled.

The third option has an internal repeater so that it can be used on a single highway and allows the highway to be extended in distance or number of units without an external repeater. The repeater option also allows connection in a ring topology. Communications is normally through a master at one end of the ring. If the ring gets broken, a second master communicates with all the devices downstream of the break, from the other end of the ring. This also allows continued communication with all devices after a cable break or short-circuit.

Modbus Commands

The single channel option is the simplest implementation of the Modbus module to apply. There is only one RS-485 highway connection to the actuator and only one channel inside the actuator for communication.

The module operates as an RTU slave on the network and uses only one address.

- 2-wire RS-485 Single Communications Highway
- Full actuator control and data reporting
- Network or tool selectable termination
- Full isolation on the RS-485 connection
- Includes lightning protection on RS-485 highway connection
- Fully network configurable

Modbus RTU

The protocol used for the communication is Modbus RTU (Remote Terminal Unit). This is the most common Modbus application, where each network will have one master, usually a PLC or DCS, and several slave devices. In all cases the Rotork module is a slave device and will only send a message in response to a request from the master on the system.

Because all messages are under the control of the master there should never be any data collisions or interruptions. The master also controls the message retry mechanism and monitors each slave for its responses to requests for data. Only one slave device at a time sends messages on the highway.

The Rotork module only supports half duplex communication. On a 2-wire RS-485 Communications Highway cable the pair is used for passing messages in one direction at a time, either from the master to the slave, or vice versa. This means the master is transmitting only half of the time, hence using half duplex communication. Full duplex requires 4 wires and is more complex, while a half duplex communication system is easier to troubleshoot and keep running.

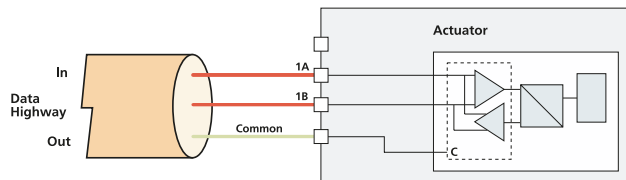

Modbus Features

Dual Channel Module

The dual channel version caters for those applications where redundant highways are being used for high integrity field connection. The two channels are isolated from one another and provide independent communications.

Both channels share the same processor and baud rate for the communications. The address of each channel may be the same or different to the other.

The ability to use dual highways makes this version ideal for critical installations where redundant communication paths are required.

- Two 2-wire RS-485 communication highways
- Full actuator control and data reporting
- Network or tool selectable termination
- Full isolation on both channels and between channels
- Includes lightning protection on each RS-485 highway connection
- Channel 1 takes priority over Channel 2 when simultaneous messages are received
- Fully network configurable
- Common or different address for the two channels
- Common communication speed for both channels

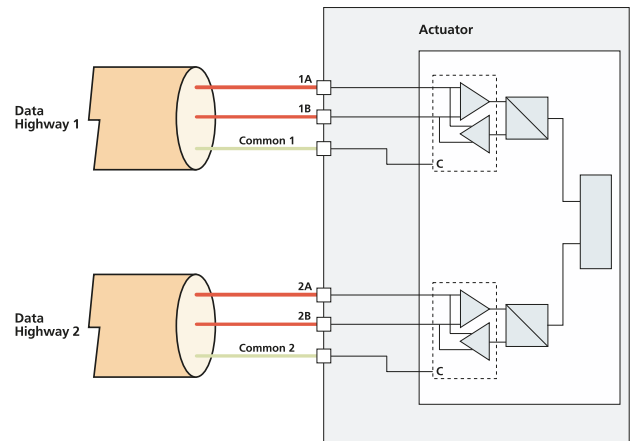

Single Channel plus Repeater Module

The single channel with repeater Modbus module includes an internal repeater to allow the highway to be extended over greater distances, or for those applications where a ring is to be constructed. The repeater works in both directions and has minimal turn round time between transmit and receive modes.

The number of connected modules can be extended to over 32 using the repeater version, however the recommendation for repeaters is that no more than 9 are used in a system. With 9 repeaters it is easy to build a system over 15 km in length that will run at 9600 baud.

The operation is similar to the single channel unit with the addition of the repeater function.

- Two connections for single RS-485 highway use
- Full isolation between the two segments
- Minimal turn round time within the repeater to ensure maximum speed communication
- Allows for spur and ring topology networks
- Includes lightning protection on each RS-485 highway connection
- Network or tool selectable termination on both segments

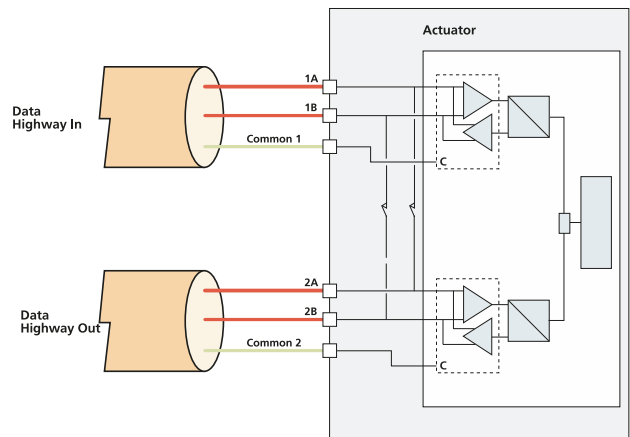

Modbus Features

Control and Feedback

The Modbus module allows data to be collected from the actuator about the status of the valve and actuator combination. This data includes logging features when the module is in an IQ or IQT actuator.

In addition, full digital and analogue control of the actuator is available without the need to add more components to the actuator.

Control Data	IQ/IQT	CK	Q	CVA	CMA	ROMpak	SKIL/EH	K
Digital Outputs:								
Stop	✓	✓	✓	✓	✓	✓	✓	✓
Close	✓	✓	✓	✓	✓	✓	✓	✓
Open	✓	✓	✓	✓	✓	✓	✓	✓
ESD	✓	✓	✓	✓	✓	✓	✓	✓
Relay 1	✓*	X	X	X	✓	X	X	X
Relay 2	✓*	X	X	X	✓	X	X	X
Relay 3	✓*	X	X	X	✓	X	X	X
Relay 4	✓*	X	X	X	✓	X	X	X
Partial Stroke	✓	X	X	X	X	X	✓	X
Analogue Outputs:								
Desired position	✓	✓	✓	✓	✓	✓	✓	✓

* Extra relay board must be fitted.

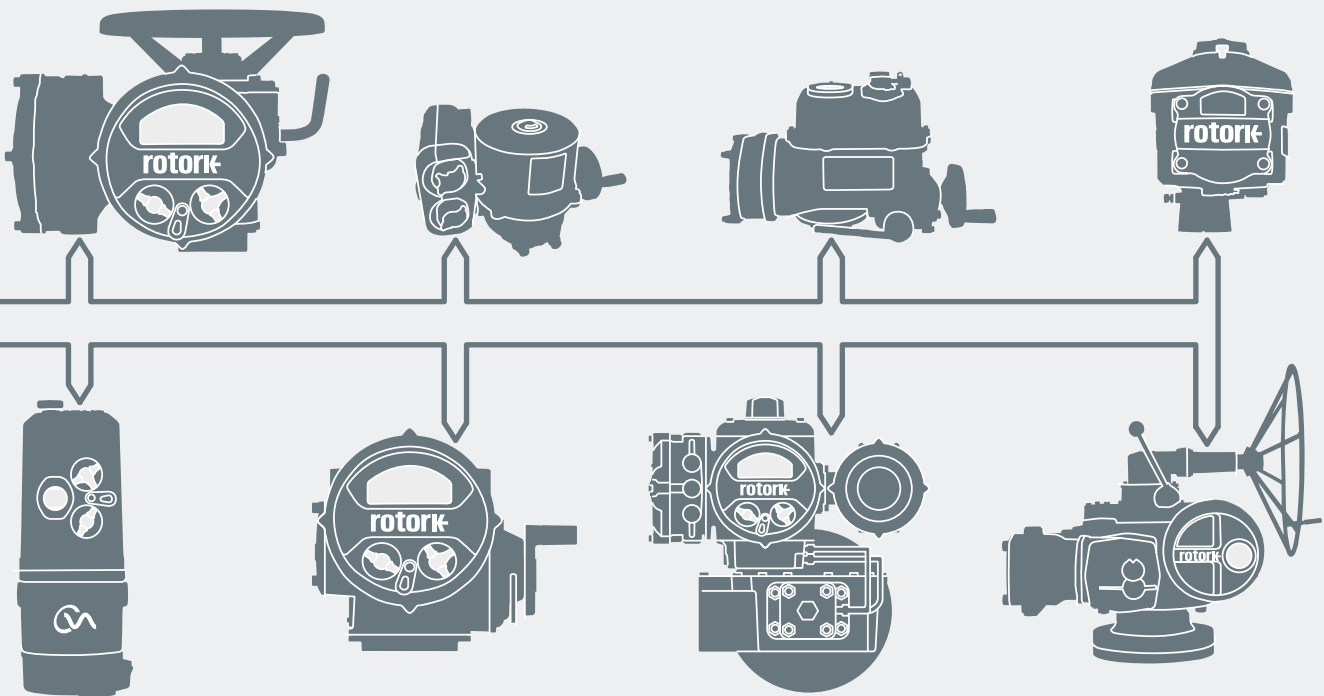

Modbus Features

Feedback Data	IQ/IQT	CK	Q	CVA	CMA	ROMpak	SKIL/EH	K
Digital Inputs:								
Actuator moving	✓	✓	✓	✓	✓	✓	✓	✓
Close limit switch	✓	✓	✓	✓	✓	✓	✓	✓
Open limit switch	✓	✓	✓	✓	✓	✓	✓	✓
Actuator running closed	✓	✓	✓	✓	✓	✓	✓	✓
Actuator running open	✓	✓	✓	✓	✓	✓	✓	✓
Remote control selected	✓	✓	✓	RUN	✓	✓	✓	✓
Selector in Remote	✓	✓	✓	STOP	✓	✓	✓	✓
Selector in Local	✓	✓	✓	1	✓	✓	✓	✓
Thermostat tripped	✓	✓	✓	✓	✓	X	2	✓
Monitor relay	✓	✓	✓	✓	✓	✓	✓	✓
Valve Obstructed / Jammed	✓	✓	✓	✓	✓	✓	✓	✓
Manual movement	✓	✓	✓	✓	X	✓	✓	✓
Motion inhibit timer active	✓	✓	✓	X	X	✓	✓	✓
Positioner control enabled	✓	✓	✓	X	✓	✓	✓	✓
Watchdog tripped	✓	✓	✓	3	X	✓	✓	X
Slow mode	4	X	X	X	X	X	X	X
Open interlock input	✓	X	X	X	X	X	X	✓
Close interlock input	✓	X	X	X	X	X	5	✓
Battery low	✓	X	X	6	X	X	✓	X
Aux input 1	✓	X	X	X	X	X	✓	✓
Aux input 2	✓	X	X	X	X	X	✓	✓
Aux input 3	✓	X	X	X	X	X	✓	✓
Aux input 4	✓	X	X	X	X	X	✓	✓

Analogue Inputs:

Measured actuator position	✓	✓	✓	✓	✓	✓	✓	✓
Current actuator torque	✓	X	X	7	✓	X	X	X

- 1 Manual control using Enlight. (see www.rotork.com)
- 2 Fault Relay
- 3 UPS Fault
- 4 IQT only
- 5 HW Partial Stroke input
- 6 UPS in use
- 7 Torque on CVA, Thrust on CVL

Modbus Features

Valve Torque Profile Data

With IQ and IQT actuators the Modbus module also makes available some of the standard data logger feedback information. A torque profile is provided in each direction together with the total number of times the motor starter has been energised in each direction. There is a short delay after the actuator stops (around 2 seconds) before this data is compiled and presented to the network.

Starts - Open	7346
Starts - Close	7782

The registers containing this information can be accessed periodically to update the control system with the latest data.

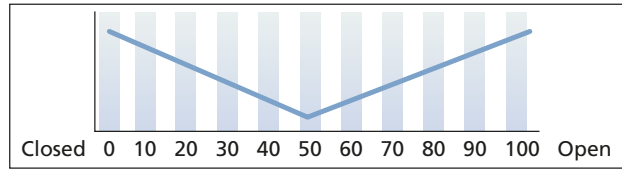

Opening Direction Torque

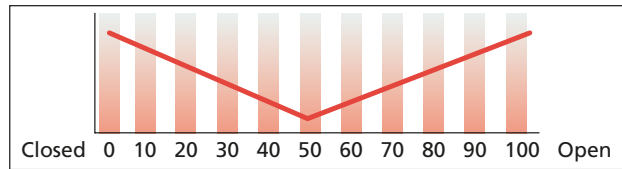

Closing Direction Torque

Function Code Support

The Modbus module supports all the major function codes and uses a technique whereby data and commands can be read and written using more than one code. For example, all actuator control and indication can be obtained using register read/write functions 03 and 16, or discrete inputs can be read with function 02 and so on.

Full position control of the actuator can be achieved by writing a value to the position control register.

Code	Function
01	Read Output Coil status
02	Read Input status
03	Read Holding register
04	Read Input register
05	Force single coil
06	Preset single register
07	Read Exception status
08	Loopback Diagnostic test
15	Force multiple coils
16	Preset multiple registers
17	Report Slave ID

Configuration

The Modbus module requires a number of configurable parameters to be set, including the address and baud rate for communication. All the parameters may be set using the communication link itself.

In most cases, the default setting will match the valve operation. To cater for those more exacting applications, the ability to match the communication and actuator performance to the valve characteristics is invaluable.

In the case of the IQ and IQT actuator the primary parameters can be set using the actuator infra-red communication link.

Description
Modbus Address
Baud Rate (baud) & Parity/Stop bits
Actuator Tag Name
Action on Loss of Communications
Limited Range Position Min & Max
Deadband and Hysteresis
Motion Inhibit Time
Aux Input Mask & ESD DI-4/Net Disable
Valve Jammed Time
Manual Movement Travel
Watchdog Timeout & Communications Fault Timer
Analogue Input Max
Network Termination off/on

Modbus Features

Lightning Protection

All the communications ports on each variant of the Modbus module are fitted with components designed to reduce the effect of high voltage induced signals, such as those generated by a lightning strike.

A combination of gas discharge tubes, rectifier diodes and Zener diodes ensures that in most cases the induced voltage levels cause no damage to the communication network.

To make full use of the internal protection, the screen should be earthed and a separate common wire should be used.

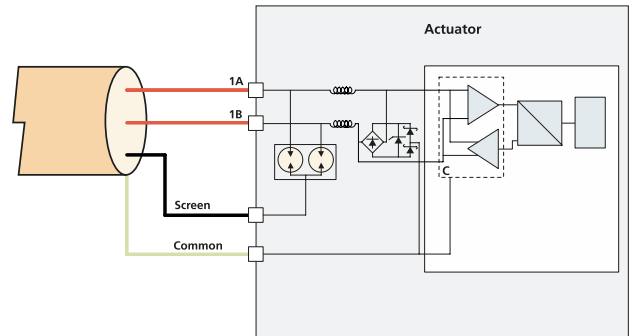

Modbus Technical Data

Interface:	EIA-485 (RS-485) suitable for 2-wire connection.
Number of Channels:	1 on Single channel, fully isolated from the actuator circuits. 2 on Dual channel, fully mutually isolated. 2 on Single channel with repeater, fully mutually isolated.
Address Range:	1 to 247, address 0 reserved for broadcast messages.
Data Rate:	300 to 115k2 baud, selected over the Modbus network.
Parity:	Configurable, odd, even or none.
Communication Protocol:	Modbus RTU (slave device).
Function Codes:	All popular function codes including 01, 02, 03, 04, 05, 06, 07, 08, 15, 16.
User Defined Digital Inputs:	4 off (IQ, IQT, SI/EH only), potential-free input contacts.
User Defined Digital Outputs:	4 off contacts 5 A, 120 VAC or 1 A, 30 VDC (IQ/IQT and CMA require additional relay board option).
Enclosure:	Suitable for fitting within Rotork IQ, IQT, CK, SI/EH, K, ROMpak and Q range actuators.
Environment:	-40 to +70 °C, environmentally protected by Rotork actuator double-sealing to IP68 (IQ, IQT, CK, SI/EH, K and Q ranges).
Power Consumption:	All Modbus module power is taken from the actuator, no external supply is required.



rotork®



www.rotork.com

A full listing of our worldwide sales and service network is available on our website.

Rotork plc
Brassmill Lane, Bath, UK
tel +44 (0)1225 733200
email mail@rotork.com

PUB091-001-00
Issue 07/23

As part of a process of on-going product development, Rotork reserves the right to amend and change specifications without prior notice. Published data may be subject to change. For the very latest version release, visit our website at www.rotork.com

The name Rotork is a registered trademark. Rotork recognises all registered trademarks. The Bluetooth® word mark and logos are registered trademarks owned by Bluetooth SIG, Inc. and any use of such marks by Rotork is under license. Published and produced in the UK by Rotork. POLJB0423