

rotork®

DeviceNet



DeviceNet
CONFORMANCE TESTED

**Controller Area Network
control of Rotork actuators**

Redefining Flow Control

Contents



Section	Page
Actuator Control	4
DeviceNet® Fieldbus Systems	5
Controller Area Network (CAN)	5
DeviceNet® Features	5
Rotork DeviceNet® Actuators	6
Cable Topology	6
Independent Certification	6
DeviceNet® Data Highway	7
DeviceNet® Performance	8
EDS Device Description File	10
Lightning Protection	11
DeviceNet® Technical Data	11



Rotork is the global market leader in valve automation and flow control. Our products and services are helping organisations around the world to improve efficiency, assure safety and protect the environment.

We strive always for technical excellence, innovation and the highest quality standards in everything we do. As a result, our people and products remain at the forefront of flow control technology.

Uncompromising reliability is a feature of our entire product range, from our flagship electric actuator range through to our pneumatic, hydraulic and electro-hydraulic actuators, as well as instruments, gear boxes and valve accessories.

Rotork is committed to providing first class support to each client throughout the whole life of their plant, from initial site surveys to installation, maintenance, audits and repair. From our network of national and international offices, our engineers work around the clock to maintain our position of trust.

Rotork. Redefining flow control.

Introduction

DeviceNet® network compatible actuators from Rotork follow the open international standard published by ODVA.

Rotork electric actuators may be controlled over the low cost network using the DeviceNet CAN bus protocol when they are fitted with the Rotork DeviceNet option module.



DeviceNet[®]
CONFORMANCE TESTED



DeviceNet Actuator Control

DeviceNet:

- International Open Fieldbus Standard.
- CAN (Controller Area Network) bus communication.
- Data transfer at 125, 250 or 500 kbaud.
- 64 devices per highway.
- Supports trunk line and drop line configurations.
- Highly reliable standardised communications.
- Simplified connectivity.
- Cabling requires 2 Data wires and 2 power wires which can be in the same cable.

Rotork DeviceNet module:

- Compatible with all IQ, IQM, IQT, IQTM, SI/EH and Q range electric actuators.
- Low installation costs.
- High control system flexibility.
- Simple plant expansion.
- Independently certified by the Open DeviceNet Vendor Association.



DeviceNet[®]
CONFORMANCE TESTED

For more information on DeviceNet[®] consult your regional ODVA centre. The ODVA web site at <http://www.ODVA.org> provides answers to many common questions. Installation information and a full list of approved devices is available from the Open DeviceNet Vendors Association.

Images on this page, top to bottom:
IQ Pro, IQT, EH, Q Range actuator.

DeviceNet Fieldbus Systems

DeviceNet is a low cost communications link to connect process control or industrial devices such as actuators, pressure transmitters and level sensors to a network and eliminate expensive cabling. The direct connectivity provides process control information as well as important diagnostic data that would otherwise not be accessible over a conventional hardwired system.

DeviceNet is an Open Network Standard and Rotork is one of many registered manufacturers who supply equipment that meets this standard. The Open DeviceNet Vendor Association controls the standard and enforces the registration and acceptability of equipment for use on DeviceNet networks.

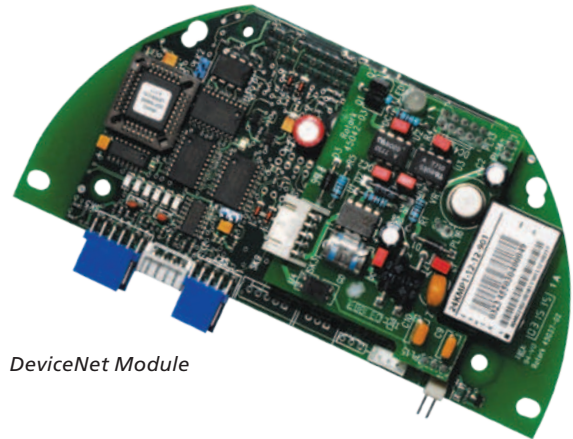

DeviceNet Module

DeviceNet Features

Features:

- Simple to install, DeviceNet networks provide dramatic reductions in cabling and installation costs.
- Speed of installation cuts time to project completion.
- Robust, efficient data handling because it is based on Producer/Consumer technology.
- Modern communications model offers key capabilities that allow the user to apply a deterministic approach to gathering information.
- Rotork DeviceNet option card supports Master/Slave and Polled communications, acting as a slave on the DeviceNet network.

DeviceNet supports up to 64 differently addressed nodes (0-63), though in general, MAC ID 63 is not used in a configured system, as this is the default address for any new hardware introduced onto the highway. In DeviceNet the Media Access Control Identifier (MAC ID) is the node address. When connected to the network, the Rotork card will automatically detect a duplicate MAC ID and not permit communication if its address is already in use.

Connection to the network requires 5 wires (2 pairs and a drain wire from the screen). A single twisted and screened pair is used for the CAN bus data signals and a second pair, generally of larger cross section conductors, is used for the 24 VDC power carried by the DeviceNet system. The Rotork actuator does not require a special connector for coupling to the DeviceNet network.

The DeviceNet option card is automatically described to the PLC or host system by an Electronic Data Sheet (EDS) file which identifies the display and control parameters and data exchange permitted with the Rotork actuator. In addition, the EDS file includes the parameters used for setting the actuator and system performance. One common EDS file is used for all actuator types, making system integration a simple task.

Controller Area Network (CAN)

The DeviceNet communication link is based on the well established and proven CAN system. The CAN network was originally developed for 'in vehicle' use in the automotive market where its high reliability and fast response is employed for demanding applications such as anti-lock brake control and air bag release.

The success of the network and the ability to operate in harsh conditions of temperature and electrical noise soon led to the CAN system being used in industrial and process control systems. Several different network protocols have evolved from this original beginning.

DeviceNet is a version of CAN that suits itself to PLC hardware input and output functions as well as electric actuator and motor control in general.

	Rotork DeviceNet Option
Network Size	Up to 64 nodes (MAC ID 00 to 63)
Network Speed	125, 250, 500 kbaud
Data Packets	8 bytes feedback, 4 bytes output
Bus Topology	Linear (trunk/drop line)
Bus Addressing	Polled, master/slave.
System Features	Removal and replacement of devices from the network under power

DeviceNet Actuator Control

Plug in Option Board

The DeviceNet option module is available for all IQ, IQM, IQT, IQTM, SI/EH and Q range electric actuators. The module is environmentally protected inside the actuator electrical housing. Once present, all of the actuator control functions and feedback data become available at the actuator terminals on the DeviceNet data highway. All communication and control related parameters can be configured by a DeviceNet configuration tool such as RS NetWorx via the highway. The standard actuator controls remain available for use even when the option board is fitted.

Dedicated Functionality

The DeviceNet option module is dedicated to the DeviceNet function. The interface, processor and firmware loaded are optimised for use with the CAN bus and DeviceNet protocol. The actuator settings made during the connection and configuration of the DeviceNet card are stored in non-volatile EEPROM and protected against corruption by a sophisticated error check. There are no switches or links that require adjustment. The DeviceNet card setting is totally nonintrusive.

Independent Certification

The Open DeviceNet Vendor Association has independently tested and certified the Rotork DeviceNet module (DFU) as conforming to the latest DeviceNet standards.



Cabling Topology

DeviceNet permits mixed cabling practices of both Trunk and Drop line cables. All systems require at least two line terminators, one on each end of the Trunk line. A Drop line may include several nodes in a daisy chain, but must be kept below 6 metres in length. The total cumulative drop length must always be assessed and used in determining the system communication speeds permitted.

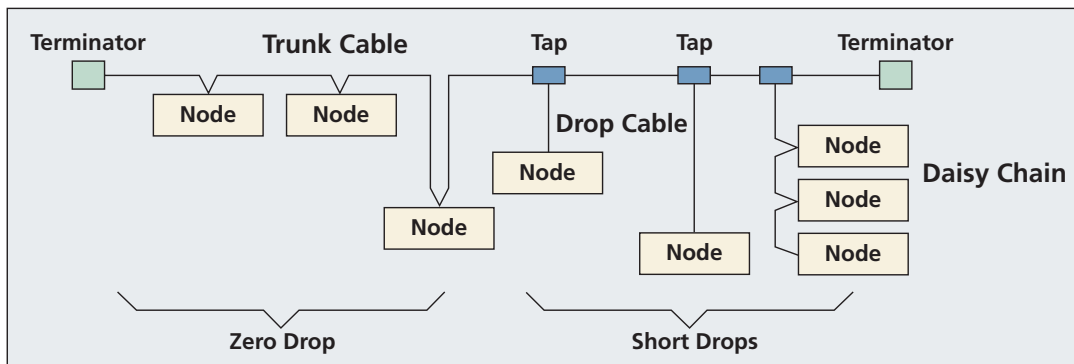

Data Rates	125 kbaud	250 kbaud	500 kbaud
Trunk Length (Thick)	500 metres	250 metres	100 metres
Trunk Length (Thin)	100 metres	100 metres	100 metres
Trunk Length (Flat)	380 metres	200 metres	75 metres
Max Drop Length	6 metres	6 metres	6 metres
Cumulative Drop	156 metres	78 metres	39 metres
Number of Nodes	64	64	64

Note that each actuator includes up to 0.67 metres of Drop length

DeviceNet Data Highway

Cable

The DeviceNet data highway uses 5 wires including a drain connected to the shield of the cable. The length of the highway depends on both the cable chosen (thick, thin or flat) and the communication speed. Two of the conductors are used for 24 VDC power and up to 8 amps (4 amps for NEC Class 2) may be passed along the highway from a suitable power supply.

Two conductors are used for the CAN bus signals, CAN_H and CAN_L; these are usually of a smaller diameter than the power conductors. The whole cable has an overall screen and the final wire is a bare drain connection to the screen. Cables to the DeviceNet standard are supplied by several manufacturers including Beldon, whose 3082A cable meets the Thick Cable specification.

Trunk Cable (Thick)

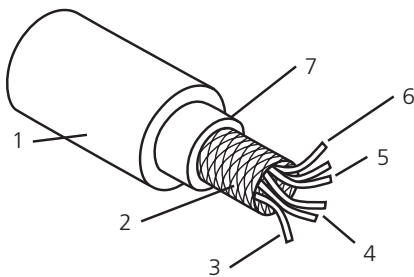

- 1 - Vinyl Jacket 12.2 mm (0.48") outside diameter
- 2 - 65% coverage tinned copper braid shield
- 3 - Stranded drain wire, 19x30 (18 AWG), tinned copper conductor
- 4 - Red & Black DC Power pair, PVC/Nylon insulation, 19x28 (15 AWG) tinned and stranded copper conductors
- 5 - Blue & White data pair, Datalene insulation, 19/30 (18 AWG) tinned and stranded copper conductors
- 6 - Polypropylene fillers
- 7 - Beldfoil Aluminium/Polyester shield

Connection

In order to simplify installation the cable conductors are colour coded to the DeviceNet standard. The Rotork actuator uses a normal actuator screw connection terminal block in the standard terminal compartment. Details of the connections are included in the actuator wiring diagram.

The Rotork actuator requires all connections to be made. The V- is used as the reference line between all the nodes. The DeviceNet module draws only 5 mA from the 24 V power supply.

All internal actuator circuits are isolated from the network.

Colour	Function	Usage
Red	V+(24 VDC)	Power
White	CAN_H	Signal
Bare	Drain	Shield
Blue	CAN_L	Signal
Black	V- (0 VDC)	Power

Highway Termination

All DeviceNet highways must be terminated at each end of the system Trunk line using a 120 Ohm resistor. These will usually be near the scanner PLC and near the furthest actuator.

If the termination resistors are not fitted there is a possibility that the network communications will be unsatisfactory. The actuator does not include a termination resistor.

Drop Lines

The use of drop line connections is permitted on the highway. The length of a single drop line must be kept to 6 metres maximum.

The total cumulative drop line total that is permitted depends on the data speed being used, at 125 kbaud the total must not exceed 156 metres. The actuator internal cabling must be included in the drop line budget when calculating the network cable lengths.

Actuator Type	IQ/IQM	IQT/IQTM	Q
Internal Drop length (metres)	0.67	0.6	0.3

DeviceNet Control Features

Feedback and Control

The data returned from the actuator is contained in an 8 byte string (64 bits) to ensure that even the simplest DeviceNet equipped PLC can be connected to the Rotork DeviceNet module. The control output data is similarly contained within a 4 byte string to keep the data transactions to a minimum.

This simple approach ensures minimal configuration of the host scanner card. All control and status information is exchanged using I/O messaging between the host and the Rotork actuator.

Control Data	IQ	IQM	IQT	IQTM	Q	SKIL/EH
Digital Outputs:						
Stop	✓	✓	✓	✓	✓	✓
Close	✓	✓	✓	✓	✓	✓
Open	✓	✓	✓	✓	✓	✓
ESD	✓	✓	✓	✓	✓	✓
Positioner enable	✓	✓	✓	✓	✓	✓
Relay 1*	✓	✓	✓	✓	X	X
Relay 2*	✓	✓	✓	✓	X	X
Relay 3*	✓	✓	✓	✓	X	X
Relay 4*	✓	✓	✓	✓	X	X
Analogue Outputs:						
Desired actuator position	✓	✓	✓	✓	✓	✓

* Remote input and relay board must be fitted

Explicit Messaging

The set up parameters for the module are set over the DeviceNet highway using Explicit messages. These parameters are used to fine-tune the actuator and control system performance to obtain the best possible results.

The Parameter objects are listed in the Electronic Data Sheet (EDS file) which is common to all the actuator types. The EDS is used by the configuration tool to identify the parameters being displayed and altered.

Explicit Parameterisation Data
Action on loss of communications
Motion inhibit timer
Positioner deadband
Positioner hysteresis
Valve jammed timer
Manual movement detection
Watchdog timeout
Disable bus control
Analogue input max value scaling
DeviceNet address (MAC ID)
Network baud rate

DeviceNet Control Features

Feedback Data	IQ	IQM	IQT	IQTM	Q	SKIL/EH
Digital Inputs:						
Actuator moving	✓	✓	✓	✓	✓	✓
Close limit switch	✓	✓	✓	✓	✓	✓
Open limit switch	✓	✓	✓	✓	✓	✓
Actuator running closed	✓	✓	✓	✓	✓	✓
Actuator running open	✓	✓	✓	✓	✓	✓
Remote control selected	✓	✓	✓	✓	✓	✓
Local stop selected	✓	✓	✓	✓	✓	✓
Local control selected	✓	✓	✓	✓	✓	✓
Thermostat tripped	✓	✓	✓	✓	✓	*2
Monitor relay	✓	✓	✓	✓	✓	✓
Valve Obstructed / Jammed	✓	✓	✓	✓	✓	✓
Manual movement	✓	✓	✓	✓	✓	✓
Motion inhibit timer active	✓	✓	✓	✓	✓	✓
Positoner control enabled	✓	✓	✓	✓	✓	✓
Watchdog tripped	✓	✓	✓	✓	✓	✓
Slow mode	X	X	✓	✓	X	✓
Open interlock input	✓	✓	✓	✓	X	X
Close interlock input	✓	✓	✓	✓	X	*3
Battery low	✓	✓	✓	✓	X	✓
Aux input 1	✓	✓	✓	✓	X	✓
Aux input 2	✓	✓	✓	✓	X	✓
Aux input 3	✓	✓	✓	✓	X	✓
Aux input 4	✓	✓	✓	✓	X	✓
Analogue Inputs:						
Measured actuator position	✓	✓	✓	✓	✓	✓
User Analogue input channel	✓	✓	✓	✓	✓	✓
Current actuator torque value	✓	✓	✓	✓	X	X

*1 Test Mode

*2 Fault Relay

*3 H/W Partial Stroke input

Note: The Aux input 1-4 and Relay 1-4 outputs may be used for direct actuator remote control and indication.

EDS Device Description File

All parameters are described in the Rotork DeviceNet module device description EDS file. This file is common for all the actuator types. It allows the configuration of the actuator control and alarm monitoring to be tailored to the specific requirements for the valve.

Functions such as motion inhibit time, position control deadband, action on loss of communications and critical parameters such as baud rate and address are set by the configuration tool using Explicit messaging. The EDS file is not needed for running the actuator, and is only used for configuration by a network tool such as RS Networkx.

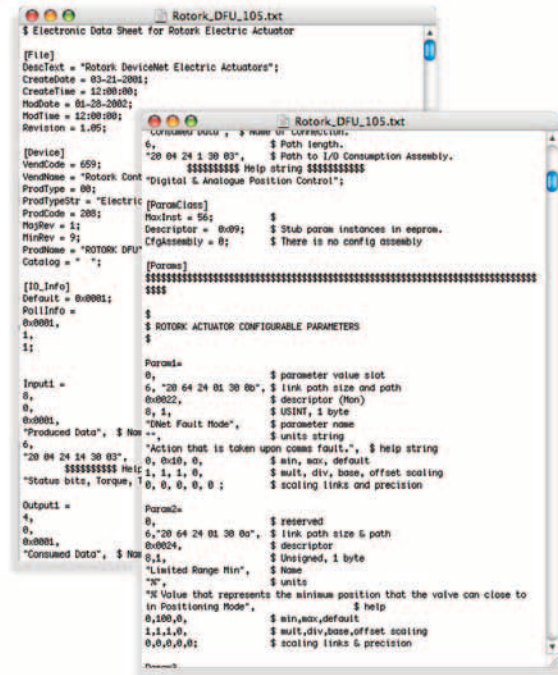

```
Rotork_DFU_105.txt
$ Electronic Data Sheet for Rotork Electric Actuator

[File]
DescText = "Rotork DeviceNet Electric Actuators";
CreateDate = 03-21-2001;
CreateTime = 12:00:00;
ModDate = 01-20-2002;
ModTime = 12:00:00;
Revision = 1.05;

[Device]
VendorCode = 659;
VendorName = "Rotork Cont";
ProdType = 00;
ProdTypeStr = "Electric";
ProdCode = 200;
MajorRev = 1;
MinorRev = 9;
ProdName = "ROTORK DFU";
Catalog = " ";

[IO_Info]
Default = 0x0001;
PollInfo =
0x0001,
1,
1;

Input1 =
0,
0, "20 04 24 1 30 03", $ link path size and path
0,
0x0022, $ descriptor (Hex)
0, 1, $ USINT, 1 byte
0x0001, "Net Fault Mode", $ parameter name
"Produced Data", $ Name
0, "Action that is taken upon comm fault.", $ help string
"20 04 24 14 30 03", $ min, max, default
1, 1, 1, 0, $ mult, div, base, offset scaling
0, 0, 0, 0, 0; $ scaling links and precision

Output1 =
4,
0,
0, "20 64 24 01 30 0a", $ link path size & path
0x0024, $ descriptor
0, 1, $ Unsigned, 1 byte
"Limited Range Min", $ Name
"R", $ units
"R Value that represents the minimum position that the valve can close to
in Positioning Mode", $ help
0, 100, 0, $ min, max, default
1, 1, 1, 0, $ mult, div, base, offset scaling
0, 0, 0, 0, 0; $ scaling links & precision
```



Lightning Protection

The Rotork DeviceNet Module features full optical isolation between the communications driver circuits and the internal actuator processors to ensure that no unwanted communication errors occur due to poor system integration or earth loop currents.

In addition, the unit has extensive protection against high induced voltages and currents on the communication cables, such as those produced by lightning strikes or large current switching operations. This protection includes the use of gas discharge tube arresters.

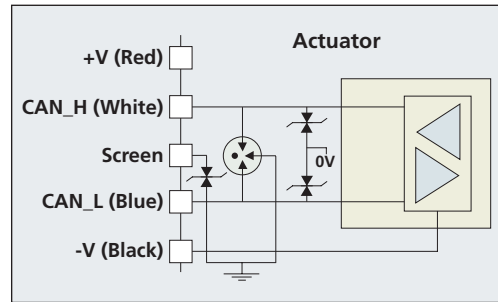

DeviceNet Technical Data

Electrical Interface:	CAN bus standard, 5 wire DeviceNet application.
Lightning Protection:	Gas discharge tubes and Varistors, 3000 A for 20 μ s.
Processor Isolation:	Optical.
Communication Protocol:	DeviceNet CAN bus, EDS file supplied in technical documentation.
Features Supported:	Set address (MAC ID) and Baud Rate via the bus.
Data Rates:	125, 250, 500 kbaud, default 125 kbaud.
Module Address:	Programmable in the range 0 to 63, default 63.
User Defined Analogue	1 off Isolated, 4-20 mA or 0-5 V input.
Input Channel:	0.1% resolution and 1% linearity at 20 $^{\circ}$ C.
User Defined Digital Inputs (IQ, IQT only):	4 off suitable for volt free contacts.
User Defined Digital Outputs (IQ, IQT only):	4 off contact outputs, 5 A, 120 VAC or 1 A, 30 VDC.
Enclosure:	Suitable for fitting within Rotork IQ, IQM, IQT, IQTM, SI/EH and Q range actuators.

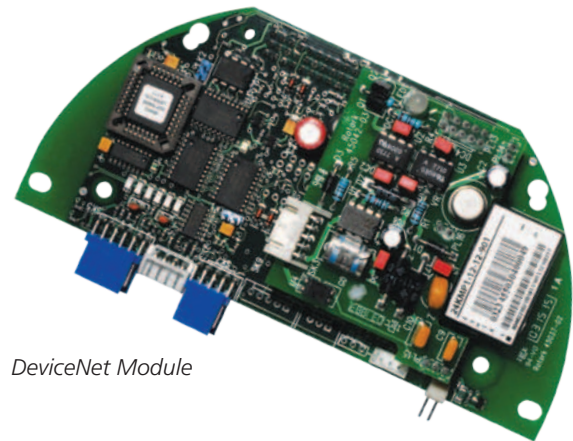

DeviceNet Module

Environment:	-40 to +70 $^{\circ}$ C, environmentally protected by Rotork actuator double-sealing to IP68.
Power Consumption:	All DeviceNet field unit operating power derived from the actuator, the interface circuit draws 5 mA from the DeviceNet 24 V power supply.

Electric Actuators and Control Systems
Fluid Power Actuators and Control Systems
Gearboxes and Gear Operators
Precision Control Instruments
Projects, Services and Retrofit

rotork®

UK

Rotork plc

tel +44 (0)1225 733200

fax +44 (0)1225 333467

email mail@rotork.com

USA

Rotork Controls Inc.

tel +1 (585) 247 2304

fax +1 (585) 247 2308

email info@rotork.com

A full listing of our worldwide sales and service network is available on our website.

www.rotork.com