

rotork

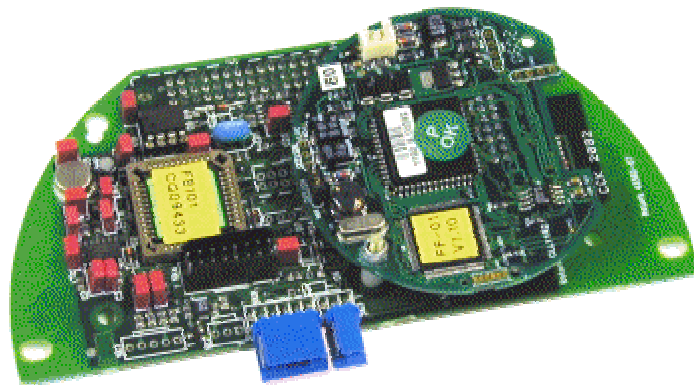

Foundation Fieldbus FF-01 Option Card Installation Manual

Note 1:

Throughout this manual the Foundation FF-01 may simply be referred to as the module.

Note 2:

The information in this manual relates to the following firmware releases

For ITK3

V1.07 for the FB302 round card from Smar
44596-01 for the Interface card

For ITK4

V1.10 or higher for the FB302 round card from Smar
44596-02 for the Interface card

Note 3:

The FF-01 module described in this manual is only suitable for inclusion in Rotork IQ , IQT, AQ and Q actuators.

As we are continually developing our products their design is subject to change without notice.

© The contents of this document are copyright and must not be reproduced without the written permission of Rotork Controls Ltd.

The name Rotork is a registered trademark

Foundation is a registered trademark by Fieldbus Foundation

Windows is a registered trademark by Microsoft Corporation

Contents

Glossary of Terms:.....	5
Abbreviations:	5
1 INTRODUCTION.....	7
1.1 General.....	8
2 FOUNDATION FIELDBUS FF-01 MODULE PROPERTIES	9
2.1 Mechanical properties	9
2.2 Electrical Properties	10
2.3 Operation and Storage	10
3 FITTING THE FF-01 MODULE	11
3.1 Inside an IQ/IQT actuator.....	11
3.2 Inside an AQ or Q actuator	12
3.3 Replacing or Fitting a Foundation FF-01 Module	13
4 IEC 61158 DATA HIGHWAY AND CONNECTIONS.....	15
4.1 Data Highway.....	15
4.2 Fieldbus Power Supply.....	16
4.3 Termination Network	17
5 THE ACTUATOR INPUT AND OUTPUT SIGNALS.....	19
5.1 Controls.....	19
5.1.1 Controls Priority	22
5.1.2 The IQ 'S' contacts.....	22
5.2 Actuator Status Feedback (Foundation).....	23
5.3 Actuator Alarm Feedback (Foundation)	25
5.4 Analogue Feedback Data (Foundation)	27
5.5 Actuator Feedback Data (Hard Wired)	27
6 FUNCTION BLOCKS	29
6.1 Resource Block	30
6.2 Analogue Input Blocks	30
6.3 Digital Input Blocks.....	31
6.4 Analogue Output Block	32
6.5 Digital Output Blocks.....	33
6.5.1 Control Source for DO 1 and DO 2	34
6.5.2 DO 3, ESD Action	35
6.5.3 DO 4, Interlock (AQ/Q only).....	35
6.5.4 DO 5 to DO 8, Relay R5 to R8 outputs (IQ/IQT only).....	36

6.6	PID Control Block – Not Available in ITK4 version 1.10 or higher	36
6.7	Transducer Block	37
6.7.1	Valve Codes	45
7	LINK ACTIVE SCHEDULER	51
7.1	Creating a Schedule	52
7.2	Connecting the Blocks	52
8.	SETTING UP THE FF-01 MODULE	53
8.1	Setting Digital Control	53
8.2	Setting Analogue Control	54
8.3	Mixed Digital and Analogue Control	54
8.2	Controlling Digital Inputs	55
8.3	Controlling the IQ/IQT Actuator Relays (DO5 to DO8)	55
8.3.1	Relay Source	55
8.3.2	Relay Trigger	56
8.3.3	Relay View	56
8.4	Hard-wired Input Monitoring and Control	56
8.4.1	Aux Input Function	56
8.4.2	Aux Input Condition	56
8.5	Viewing the Actuator Status	57
8.5.1	Analogue Position and Torque Data	57
8.5.2	Digital Command and Status Readback data	57
8.5.3	Actuator Condition Report	58
9	UPDATING THE FF-01 FIRMWARE	59
9.1	Remove the FF-01 from the Actuator	59
9.2	Connect the FF-01 to the PC and Power Supply	59
9.3	Downloading the SMAR Firmware	61
9.4	Updating the COP8 Firmware	63
9.5	Re-assemble the Actuator	64
10	DEVICE DESCRIPTION FILES	65
10.1	ITK3 DD Files	65
10.2	ITK4 DD Files	65

Glossary of Terms:

Capabilities File	A file describing the communication objects in a fieldbus device. A configuration device can use Device Description (DD) Files and Capabilities Files to configure a fieldbus system without having the fieldbus devices online.
Device Description (DD)	A file that provides an extended description of each object in the Virtual Field Device (VFD), and includes information needed for a control system or host to understand the meaning of data in the VFD.
Fieldbus	The digital, two-way, multi-drop communication links.
Field Unit	The FF-01 card fitted to the actuator
H1	A term used to describe a fieldbus network operating at 31.25 kbit/second.
Interoperability	The capability for a device from one manufacturer to interact with that of another manufacturer, on a fieldbus network, without loss of functionality
Link Active Scheduler (LAS)	A deterministic, centralised bus scheduler that maintains a list of transmission times for all data buffers in all devices that need to be cyclically transmitted. One Link Master (LM) device functions as the fieldbus LAS at any one time.
Schedules	Define when Function Blocks (FBs) execute and when data and status is published on the bus.
Segment	A section of an H1 fieldbus that is terminated in its characteristic impedance. Segments can be linked by Repeaters to form a longer H1 fieldbus. Each Segment can include up to 32 H1 devices.
Standard Function Block (FB)	These are built into fieldbus devices to achieve the desired control functionality. The FF-01 has Analogue Input (AI), Analogue Output (AO), Digital Input (DI), Digital Output (DO) and PID control.
Transducer Block (TB)	These blocks decouple Function Blocks (FBs) from the local input/output (I/O) functions required to read the limit switches and command the actuator to move.
Virtual Communication Relationship (VCR)	Configured application layer channels that provide for the transfer of data between applications.
Virtual Field Device (VFD)	A VFD is used to remotely view local device data described in the object dictionary.

Abbreviations:

Comms	Communications
FB	Function Block
FF	Foundation Fieldbus
FU	Field Unit
LAS	Link Active Scheduler
RAM	Random Access Memory
ROM	Read Only Memory
SW	Software
TB	Transducer Block

(This page is intentionally blank)

1 INTRODUCTION

The Rotork FF-01 Foundation Fieldbus Module conforms to the open fieldbus standard IEC 61158. It is suitable for use on an H1 highway and uses two copper wires for connection to the highway. It is necessary to have a suitable power supply and termination filter on the highway for the FF-01 to function.

The current version of the FF-01 card assembly may be fitted into the IQ, IQT, AQ or Q only. The FF-01 module is an integral part of the actuator in which it is housed. The module is fitted within the main double sealed electrical housing. This electrical housing need never be opened once the actuator leaves the assembly plant. All adjustments to the settings for the FF-01 module may be made via Foundation data highway using a suitable network configuration tool. There is no external marking on the actuator to show the FF-01 serial number since the module may be replaced if it should fail.

The FF-01 circuits do not impinge on the actuator control electronics; the actuator itself remains fully self-protecting. The module performs the tasks of IEC 61158 interface, actuator data collection and the issuing of actuator commands.

The FF-01 may command the actuator into which it is fitted to open, stop, close, perform an ESD operation or move to a set position. Commands to the module come from the network and may be generated in another actuator or device on the network using peer to peer, consumer/producer communication. Additionally, digital and analogue status information relating to the actuator is published for the other devices to read.

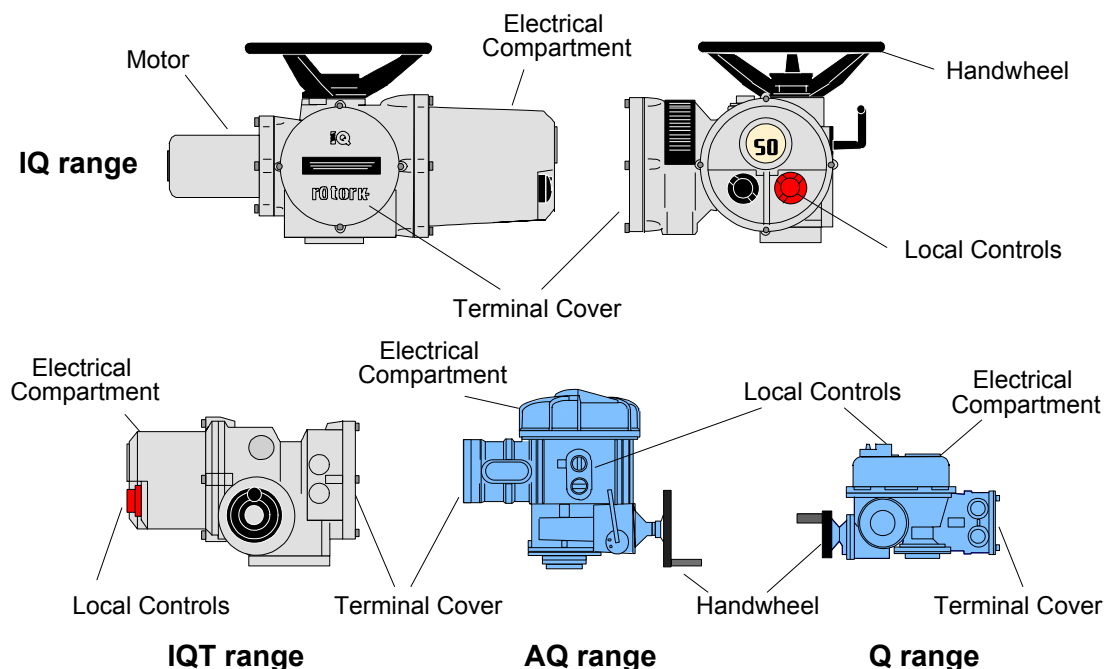

Fig 1: The FF-01 Actuator Compatibility

Supporting Documents from the Fieldbus Foundation, Austin Texas:

- Technical Overview of Foundation Fieldbus FD-043
- Wiring and Installation 31.25 kbit/s,
Voltage Mode, Wire Medium AG-140

1.1 General

The FF-01 module is capable of performing the following functions –

- a) Link Master
- b) Link Active Scheduler

The in-built function blocks vary in availability between the different actuator types. The input and output blocks are used to link to the transducer block and tie to the available actuator functions. For example the AI block associated with actuator torque measurement is not available in the Q and AQ actuators. The following table lists the function blocks and their related availability in each actuator type. In the case of the PID block this is only available in the ITK3 version of the product. The ITK4 version does not include PID.

Function Block	IQ actuator	IQT actuator	AQ actuator	Q actuator
Digital Inputs				
DI 1 (variable)	✓	✓	✓	✓
DI 2 (variable)	✓	✓	✓	✓
Digital Outputs				
DO 1 Open	✓	✓	✓	✓
DO 2 Close	✓	✓	✓	✓
DO 3 ESD	✓	✓	✓	✓
DO 4 Interlock	✓	✓	✓	✓
DO 5 Relay 1	✓	✓	x	x
DO 6 Relay 2	✓	✓	x	x
DO 7 Relay 3	✓	✓	x	x
DO 8 Relay 4	✓	✓	x	x
Analogue Inputs				
AI 1 Position	✓	✓	✓	✓
AI 2 Torque	✓	✓	x	x
Analogue Output				
AO 1 Desired position	✓	✓	✓	✓
PID *				
PID 1 3 term controller	*	*	*	*

* The PID block is not available in the ITK4 version of the FF-01. Consult Rotork for further details.

2 FOUNDATION FIELDBUS FF-01 MODULE PROPERTIES

2.1 Mechanical properties

The FF-01 module comprises two printed circuit boards that fit together and the assembly is fitted inside the actuator electrical housing.

- Round Card - The circular printed circuit board (manufactured by SMAR) carries the Foundation fieldbus highway connections and the processor handling the data highway communication and function blocks.

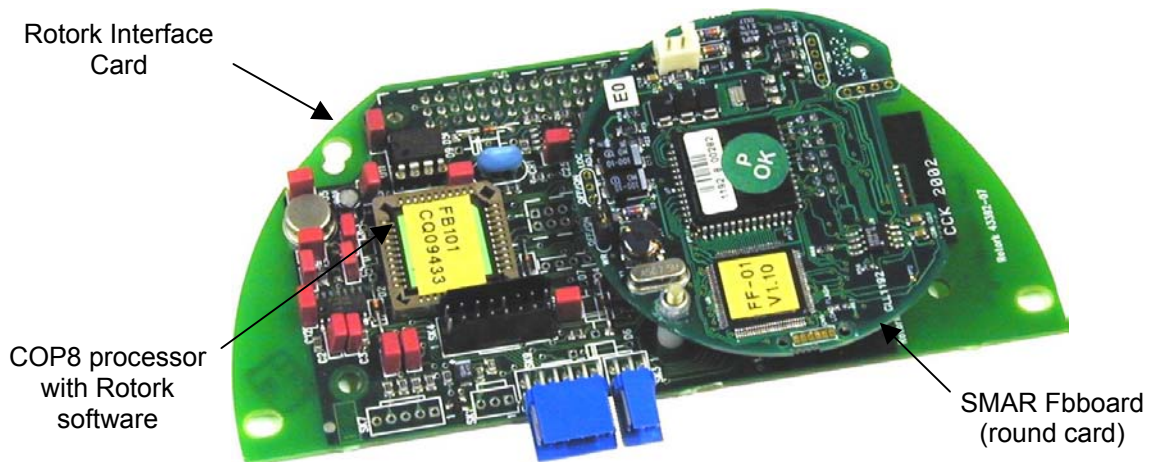

Fig 2: The FF-01 module showing the round card and Interface board (IQ actuator)

- Interface Card The larger motherboard (manufactured by Rotork) is profiled and assembled to fit an IQ actuator as shown, or AQ/Q actuator. It carries the processor for collecting the data from the actuator main board and passing this data to the round card.

The primary connection to the actuator circuits is by a multipin connector on the Interface Card, which, due to its physical shape, may only be fitted in the correct polarisation. Internal wiring harnesses connect to the Interface card for other signals and options within the actuator. The SMAR Fbboard round card carries the IEC 61158 connector, this couples to the wiring harness routed to the terminal compartment of the actuator. Power for the SMAR Fbboard round card is taken from the IEC 61158 highway whilst the Interface card is powered from within the actuator.

All the connectors are polarised to prevent incorrect insertion.

2.2 Electrical Properties

The FF-01 module Interface board connects directly to the main board of the actuator. The FF-01 does not sit in the main control path for the actuator and does not affect the actuator control integrity.

Internally stored programs control the two processors on the module. The software for the SMAR Fbboard processor can be updated by connecting a suitable test probe and sending the new code directly to the processor. The software for the Interface card is within the COP8 processor and cannot be altered except by replacement of the processor chip itself. The Foundation system allows all settings for the data highway and module communication functions to be held in non-volatile memory on the SMAR Fbboard.

The IEC 61158 data highway connection on the SMAR round card is fully isolated from the actuator electronics and the interface card.

2.3 Operation and Storage

The Module is designed to be stored in the actuator and operated within the same environment as the actuator. The constraints are:

- Operating temperature: -40°C to +70°C
- Storage temperature: -50°C to +85° C
- Relative Humidity: 5% to 95% (<50°C) non-condensing

3 FITTING THE FF-01 MODULE

3.1 Inside an IQ/IQT actuator

The FF-01 module is fitted in the first option board slot inside the IQ or IQT electrical housing using connection SK6. It is not possible to fit a second option board inside the housing.

The Interface card must be correctly profiled and loaded with the appropriate connectors to match the IQ or IQT actuator. The illustration (Fig 3) shows the IQ/IQT version of the circuit boards.

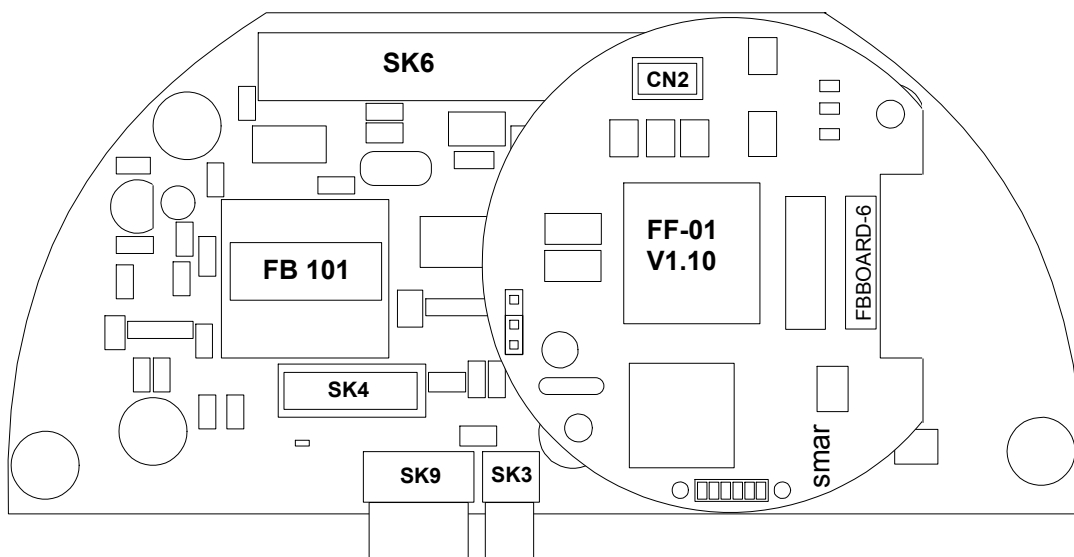

Fig 3: The FF-01 module profiled for the IQ or IQT actuator

In the case of a IQ and IQT actuator the remote inputs are always present and there is an option to include relay outputs. The following table shows the wiring harnesses that must be fitted and the function of each loom for the two types of IQ actuators.

Wiring Harness	3000/6000 Series WD	3300/6300 Series WD
CN2 – Data highway connection (current drain 20 mA)	Yes	Yes
SK3 – Remote Output drive connections	No	Yes
SK9 – Remote Input connections	Yes	Yes
SK4 – 'S' switch setting status connections	Yes	Yes

3.2 Inside an AQ or Q actuator

The FF-01 is fitted in the option board position in these actuators. Only one option board may be fitted these actuators at any one time. The necessary internal components must also be present; in this case a potentiometer must be fitted to the actuator.

The illustration (Fig 4) shows the AQ/Q version of the circuit boards.

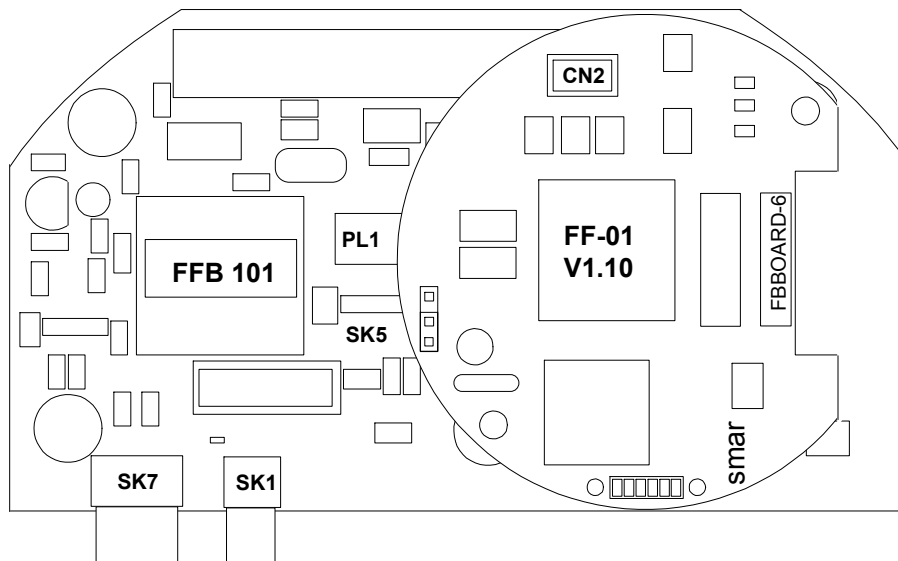

Fig 4: The FF-01 module profiled for the AQ and Q actuator

The following table shows the wiring harnesses that must be fitted and the function of each loom for these types of actuator.

Wiring Harness	AQ	Q
CN2 – Data highway connection (current drain 20 mA)	Yes	Yes
SK1 – Potentiometer	Yes	Yes
SK7 – Limit switches	Yes	Yes

The data highway connector CN2 connects to the actuator terminals.

In addition, when using the FF-01 in an AQ actuator the connection between the actuator main board and Interface card is to PL1 using a ribbon cable. In a Q actuator there is a direct connection to SK5.

3.3 Replacing or Fitting a Foundation FF-01 Module

The FF-01 module can be replaced or fitted only in a suitable environment. The actuator must be made electrically safe before opening the covers; in the case of an IQ/IQT it is advisable to disconnect the internal battery. The electrical housing cover should be removed and the existing FF-01 carefully unplugged from its main connector. Once removed from the main connector the wiring loom connectors should be removed. The replacement board is fitted in the reverse order to removal. The wiring harnesses are polarised so that only the correct one will fit its mating part on the circuit board.

If the operation is to fit a module for the first time then the necessary wiring looms must be added to the internal wiring harness according to the above description. The actuator wiring diagram shows the connectors and harnesses used. The wiring harnesses are fitted inside the actuator before attempting to fit the FF-01 module. Once the looms are in place connect them to the module, then fit the module to the main board connector.

Once the card is fitted the actuator should be re-assembled and the IQ/IQT battery replaced.

The SMAR Fbboard round card can be replaced on its own. The round card connects to the Interface card using connector SK2. If required the firmware in the SMAR Fbboard can be updated using tools available from Smar Equipamentos Ind. Ltda. or a subsidiary.

If only one half of the FF-01 module is replaced take care to ensure compatibility between the new and old part and the firmware versions fitted.

(This page is intentionally blank)

4 IEC 61158 DATA HIGHWAY AND CONNECTIONS

4.1 Data Highway

The Foundation Fieldbus network is based on the IEC 61158 data highway using copper conductors. The network also carries the power used to supply each node on the network. In the case of the FF-01 device the SMAR round card is powered from the fieldbus network. Only two wires are used for the data highway and these carry both the data signal and the module power. The actuator Interface card is powered from the actuator itself and the assembly can only report data when both the data bus and actuator are powered up.

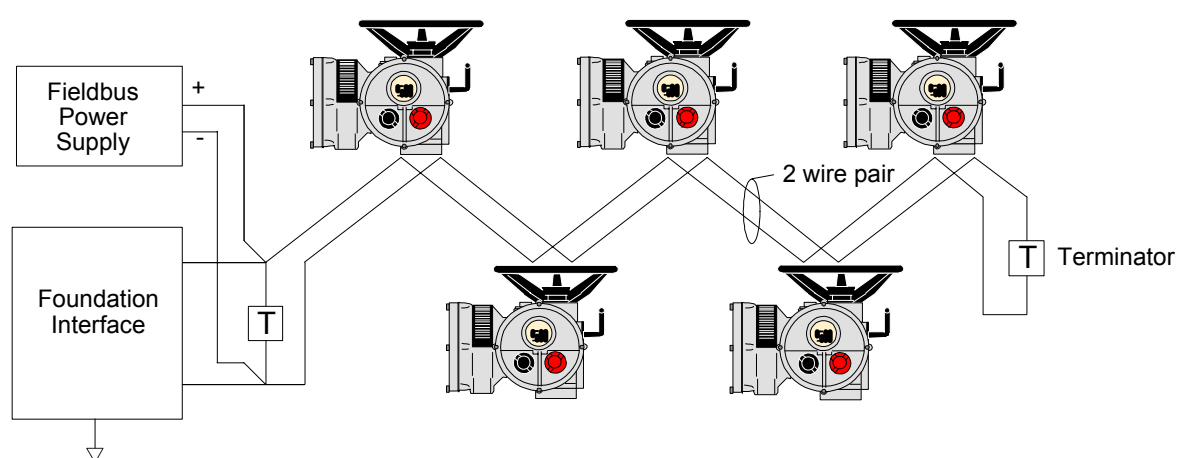

Fig 5: Typical Foundation Data Highway

The data highway must be terminated with proper balancing devices at either end. The highway can use spur or stub connections to the devices but it is recommended to keep any stub lengths to a minimum for successful operation. The length of the highway and number of devices connected will vary from project to project. The standard permits up to 32 devices before a repeater in the highway must be used. Similarly the standard calls for a maximum segment length of 1900 metres before a repeater must be used. On a 1900 metre highway the stipulated maximum length for a stub with one actuator is 120 metres. The data highway cable type is given by the Foundation as 'type A', typically Belden 3076F.

Cable Specification	Type A Cable (e.g. Belden 3076F)
Type	2 cores, twisted pair plus overall screen
Shielding	Minimum 90% copper shielding, braid or foil
Size	18 AWG (0.8 mm ²)
Resistance	24 ohms/km max
Nominal Capacitance	80 pF/m

4.2 Fieldbus Power Supply

The FF-01 module takes power from the Foundation fieldbus data highway. The SMAR round card is powered by the fieldbus so that the internal function blocks are available for control connection between devices even when the actuator has no power.

The power is taken from a special DC power supply connected onto the network through a suitable filter. The power consumption of each Rotork node on the network is 18mA (nominal) and the absolute minimum voltage at the actuator terminals is 9 volts. The power supply has to contain an inductive network to prevent attenuation of the fieldbus signal by the low impedance of the power supply itself. The inductive network in the power pack makes sure that its equivalent impedance is quite high at the 31.25 kbits/sec frequency whilst still allowing a DC current to be drawn for the line powered devices.

Since each node on the fieldbus consumes power from the DC supply great care must be taken in the design of the installation. The design must ensure that the volt drop from the power pack to the actuator still leaves at least 9V (absolute minimum) for the round card and ideally at least 10V. The actuators can withstand a maximum voltage of 32V from the power pack and since the current consumption is virtually constant a simple Ohms law calculation can be used to determine the potential at each point in the network. On power up the inrush current of the round card will exceed the nominal by a factor 3.

The Foundation fieldbus wiring guide (AG-140) provides examples of how to calculate the voltage at each point.

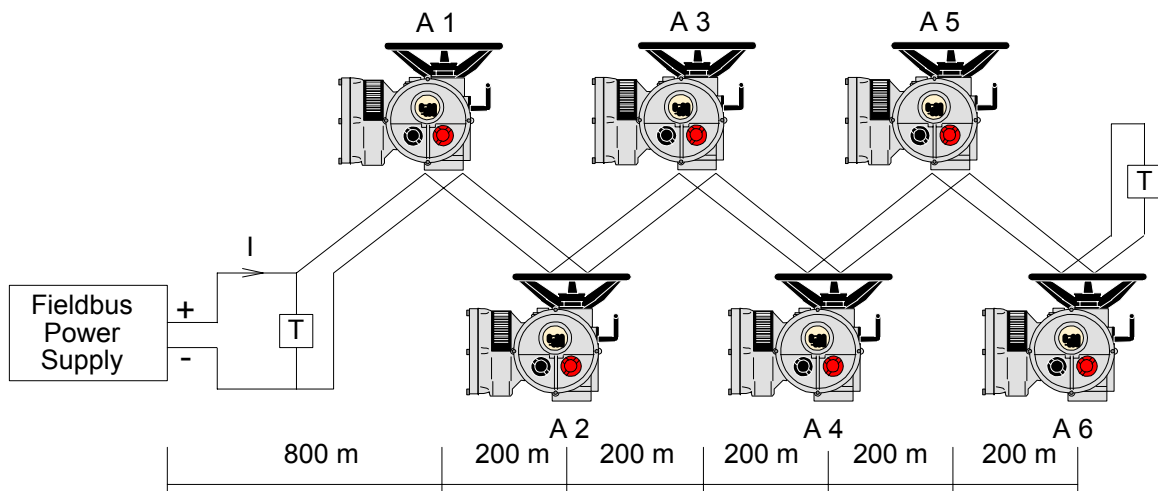

Fig 6: Calculating the Voltage Drop

Example of voltage drop calculation:

Assume the cable is Type A (24 ohm per km per conductor), the resistance of each 1000 metre pair is $24 \times 2 = 48$ ohms per km.

The current drawn by each node A1 to A6 is 20 mA.

$$\begin{aligned} \text{Voltage drop Power supply to A1} &= \text{current} \times \text{resistance} \\ &= (6 \times 0.020) \times (0.8 \times 48) = 4.6 \text{ volts} \end{aligned}$$

$$\text{Voltage drop A1 to A2} = (5 \times 0.020) \times (0.2 \times 48) = 0.96 \text{ volts}$$

$$\text{Voltage drop A2 to A3} = (4 \times 0.020) \times (0.2 \times 48) = 0.768 \text{ volts}$$

$$\text{Voltage drop A3 to A4} = (3 \times 0.020) \times (0.2 \times 48) = 0.576 \text{ volts}$$

$$\text{Voltage drop A4 to A5} = (2 \times 0.020) \times (0.2 \times 48) = 0.384 \text{ volts}$$

$$\text{Voltage drop A5 to A6} = (1 \times 0.020) \times (0.2 \times 48) = 0.192 \text{ volts}$$

$$\text{Total system volt drop} = 4.6 + 0.96 + 0.768 + 0.576 + 0.384 + 0.192 = 7.48 \text{ volts}$$

If the power supply is a 24 V unit, then the voltage at actuator A6 will be $(24 - 7.48) = 16.52$ volts which is within the specified minimum.

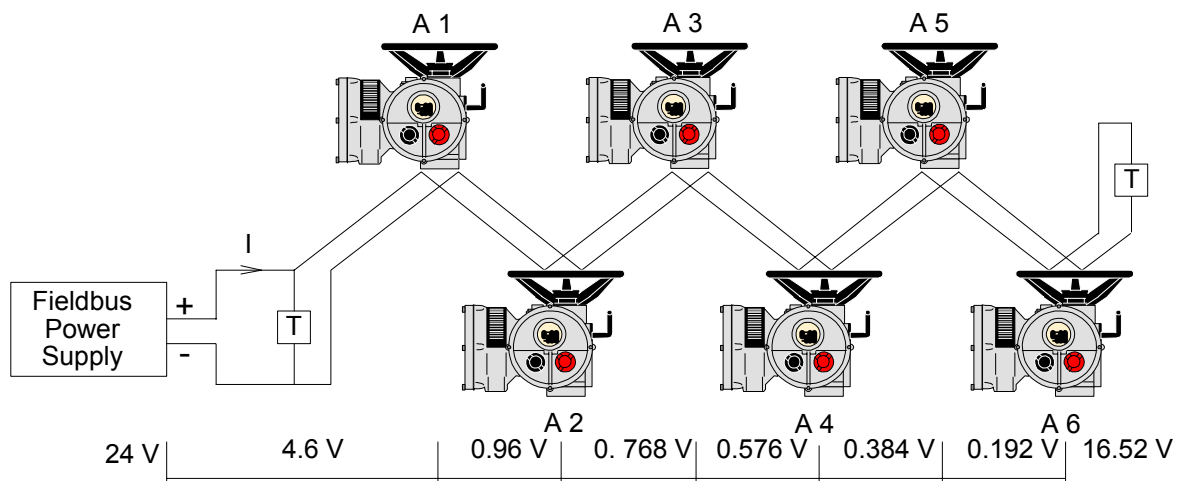

Fig 7: Voltage Drop Example

4.3 Termination Network

Each highway must be terminated correctly at the two ends of the data highway. The terminator comprises at least one resistor and capacitor in series and they provide a characteristic impedance of 100 ohm at 39 kHz. They need not be placed on the absolute ends of the highway but should be on the ends of the main trunk section.

There are no termination facilities inside the actuator itself.

(This page is intentionally blank)

5 THE ACTUATOR INPUT AND OUTPUT SIGNALS

The FF-01 module provides feedback data about its status and that of the actuator to the Foundation highway. This data is contained in the Transducer function block and is fully listed in the section on Function Blocks. The actuator is normally controlled by signals from the Foundation highway connecting to the Output blocks and the Transducer block. There are local controls on the actuator itself and there is the possibility to wire in direct contacts to control the movement. This section explains the primary data available and the meaning of the signals generated by the actuator.

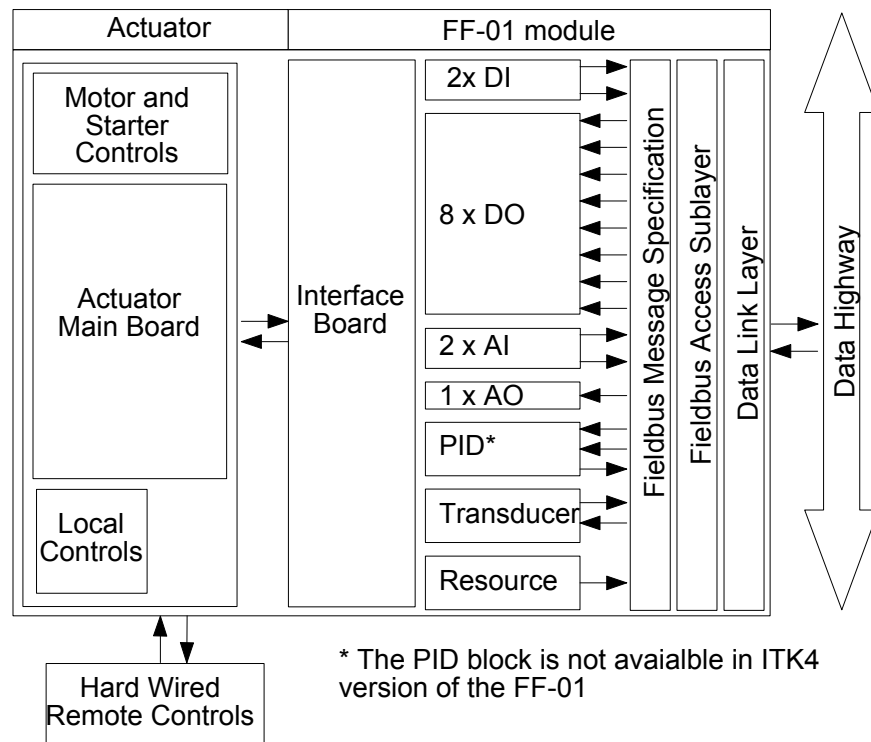

Fig 8: Actuator and FF-01 Block Diagram

Input signals are those returned by the actuator to the network about the status of the actuator and valve whilst output signals are those used to command the actuator to move or operate its internal relays. An actuator control signal such as a command to open is an output, whilst a reported status such as open limit switch reached is a feedback input.

5.1 Controls

The actuator is used to position a valve. The valve may be moved fully closed, fully open or to an intermediate position. Various controls are available to create these actions. Additionally the actuator can make the valve adopt an Emergency Shut Down position or the actuator can be prevented from moving by the presence of an Interlocking signal from another device on the plant.

The control commands have three potential sources:

- Foundation Fieldbus generated commands
- Actuator Local Controls
- Direct contact input controls

The full list of commands is shown in the table. The actuator types show whether the command is applicable to that actuator type.

Command	IQ/IQT actuator	AQ actuator	Q actuator
Foundation Network			
Open	✓	✓	✓
Close	✓	✓	✓
Stop	✓	✓	✓
Emergency Shut Down	✓	✓	✓
Interlock (active prevents any motion)	x	✓	✓
Relay R5*	✓*	x	x
Relay R6*	✓*	x	x
Relay R7*	✓*	x	x
Relay R8*	✓*	x	x
Analogue Position demand	✓	✓	✓
Local Controls			
Open	✓	✓	✓
Close	✓	✓	✓
Stop	✓	✓	✓
Direct Wired Inputs			
Open	✓	✓	✓
Close	✓	✓	✓
Stop/Maintain	✓	✓	✓
Emergency Shut Down	✓	✓	✓
Open Interlock (active prevents opening)	✓	x	x
Close Interlock (active prevents closing)	✓	x	x
Analogue Position demand	x	x	x

* requires additional relay board to be fitted.

The Foundation Fieldbus commands operate on the Transducer block through Digital Output (DO) blocks that are already connected in the default configuration.

- Open** A digital command to cause the actuator to open to the fully open position as indicated by the Open limit switch. The actuator stops either when the open limit switch is reached, or when the torque exceeds the value set and the open limit switch has been reached. The reason for stopping when open depends on the way the actuator has been set to operate during its commissioning.

- Close** A digital command to cause the actuator to close to the fully closed position as indicated by the Close limit switch. The actuator stops either when the close limit switch is reached, or when the torque exceeds the value set and the close limit switch has been reached. The reason for stopping when closed depends on the way the actuator has been set to operate during its commissioning.

Note: Many IQ multi-turn actuators are set to open until the open limit switch is reached and, close until the closing on torque switch trips, but it is dependant on the type of valve. The IQT, Q, and AQ normally operate 90-degree valves, use stop bolts on the actuator, and stop when these are reached. The control room indication is always taken from the end of travel limit switch settings

- Stop** If the Open and Close commands are both replaced with zero the actuator will stop. In the case of the local controls, the selector is placed in the stop position. For hard-wired inputs the 'maintain' line is normally closed and opens to stop the actuator.
- Emergency Shut Down** A digital command that causes the actuator to go to its Emergency position. There are settings within the actuator to determine if this is a closed, open or stay put action. ESD overrides Open, Close or Stop from either the
- Interlock** When present the actuator is prevented from opening, closing or moving depending on the state of the command. For hard wired inputs on the IQ/IQT actuator two interlocks are provided, one for opening and the other for closing. (When the DO block is written to by the Foundation there is a Transducer block mode control to view which direction is interlocked.)
- Relay R5 to R8** These 4 commands are used to energise and de-energise the additional internal relays on the remote output board in an IQ actuator. (These outputs are referred to as S5-S8 in the standard actuator documentation when there is no FF-01 module in the actuator.) The resulting outputs can be used for operating other equipment such as a pump or indication light. The IQ/IQT actuator is not able to control these relays directly from the main board by switch settings, they may only be controlled by the Foundation DO blocks.
- Analogue Position** This function is only available over the Foundation network. When a value is written to the AO block parameter (range 0-100%, resolution 1%) the valve will open to the appropriate amount and stop in that position. If a subsequent digital command to open or close the valve is issued, from any source, the analogue positioning mode is inhibited. Writing to the parameter again causes the positioning mode to recommence.

5.2 Actuator Status Feedback (Foundation)

The FF-01 module is able to report a comprehensive data set relating to the status of the valve and actuator as well as information relating to the status of the module itself. This information can be used in the construction of the control scheme and any two variables can be connected to the Digital Input blocks in the module for scheduled broadcast onto the highway. The recommended signals for connection to the DI blocks and the usual connection for the AI blocks are listed in the manual section on function blocks.

Valve and Actuator data is reported through the Transducer block and the instantiated function blocks. The Transducer block in turn uses data from the Valve Codes list. The Valve Codes are set values reported by the Transducer block that have values associated with the actual condition of the actuator and valve. Some Transducer block indices report alarm data whilst others report status. The following section describes the valve and actuator data that can be read from these Valve Codes and Transducer block. Note that within the actual Transducer block data is combined into one index that will cover a number of conditions on the actuator.

Status Feedback	IQ/IQT actuator	AQ actuator	Q actuator
Open	✓	✓	✓
Close	✓	✓	✓
Stop	✓	✓	✓
Inhibited (Motion Inhibit Timer)	✓	✓	✓
Local Override (Local)	✓	✓	✓
Position Achieved	✓	✓	✓
Torque Achieved	✓	x	x
Moving	✓	✓	✓
Aux Input 1 to 4	✓	x	x
Interrupter Timer	✓	x	x
Blinker	✓	x	x
Interlock	✓	x	x

- Open/Close**

The two internal position sensors in the actuator report the valve to be in either end of travel position, or in mid stroke when they are not true. These limit positions should be set within the actual valve stroke. When a torque seating valve is closing, the actuator will stop when the seat is reached and the rated torque has been delivered, independent of the closed limit switch setting. The position limit switch must be set slightly before the torque off position in order to ensure that the position is correctly reported. The data relating to position is maintained even though the position itself has been passed through. When the actuator has reached the closed or open limit the respective code will be set to be true.
- Stop**

Reported when the actuator is stationary in mid travel. Stop will generally not be seen in isolation and in the reported data also includes the Stop position of the Local/Stop/Remote control selector on the actuator

- Inhibited** Indicates that the actuator motor has stopped during a valve analogue positioning action whilst the Motion Inhibit Timer is running. This timer is used to ensure that the motor does not exceed its rated number of starts per hour. This bit is set after the analogue positioner reaches the required position and has stopped. It stays active for the MIT time during which the positioner outputs are disabled. In practice it will most likely be the delay seen during positioning when the actuator has overrun the desired position and needs to reverse direction to come back to the desired set point.

- Local Override** Indicates that the three-position local control selector on the actuator is in the 'Local' position. In this position it is not possible to control the actuator from the Foundation network or from remote hard wired inputs. Note that to pass from 'Local' to 'Remote' the selector has to pass through the 'Local Stop' position. If it is placed in Local Stop or Local the 'Control Not Available' alarm is generated.

- Position Achieved** Indicates that the actuator has stopped in the desired place, fully open, fully closed or in mid stroke, without generating excessive torque.

- Torque Achieved** This always indicates that the actuator has developed the preset torque maximum level. There are three possible positions the valve can be in when Torque Achieved is generated. If this occurs in mid travel between the open and closed positions it shows that there is an obstruction in the valve preventing the completion of the desired action. When this occurs at end of travel on travelling towards that end, then the valve will have achieved a tight closure or opening position. When this occurs on trying to operate the valve and move away from the current open or close position it indicates that the valve is jammed in the valve seat. This information is only available from an IQ actuator. Since the torque will no longer be generated after the motor stops the information is relayed from the last value measured. This may alter slightly on each measurement and cause the signal to fluctuate.

- Moving** When the actuator is moving as detected by the centre column rotating or the potentiometer value altering the actuator is reported as 'moving'.

For the IQ/IQT actuator only, the following status information is also available

- Aux Input 1 to 4** The 4 hard wired inputs to the IQ or IQT actuator can be used to report feedback data or to control the actuator as remote inputs. The choice of function is made during the setting up of the module during the commissioning of the system. The Aux Inputs can be individually selected to control the actuator or monitor the input. When these inputs are used for remote control they are allocated as
 - Aux 1 = Remote Open Aux 2 = Remote Close
 - Aux 3 = Stop/maintain Aux 4 = ESD

A closed contact is used to initiate the action in remote control mode, and reports a true signal in control or report only mode. These signals report the state of the input contacts.

- Interrupter Timer** This is a specific IQ or IQT function where the motor drive can be pulsed on for a period, then dwell for a period during valve travel. The effect is to increase the valve stroke time to prevent shocks to the process system as the valve opens or closes. The timer can be configured to operate over a percentage of travel in the opening and closing directions and the length of each ON and OFF pulse is configurable in the range 1 to 99 seconds using the setting tool. (Using a communicator, much wider timing range can be configured, i.e. up to 4½ hours). These features are fully described in the IQ and IQT actuator manuals.
The purpose of this input is to allow the Foundation system to be aware that the timer is in use. If, for example, the interrupter timer has been set and the actuator is travelling closed, during the periods when the actuator is not moving due to the interrupter timer, this bit will be true.
- Blinker** The IQ and IQT actuators include a ‘flasher’ function on the internal relay outputs (generally not associated with Foundation control). This input reports the status of the flasher.
- Interlock** Interlocks provide a means of inhibiting the control action of an AQ or Q actuator from opening or closing, even when commanded to do so, until a “safe to move” signal is applied via the interlock input. The interlock can be initiated by a Foundation highway signal to DO4. DO4 needs to be driven, in addition to the control signal, before the actuator moves in the required direction. This input will be true if the Interlock signal is active. (IQ/IQT interlocks are provided by hard wired inputs only)

5.3 Actuator Alarm Feedback (Foundation)

The actuator and FF-01 module are able to determine a comprehensive range of alarm situations for the valve and actuator combination. This information is available to the Foundation network from the Transducer block in the module and the Valve Codes in that block.

Alarm Status Feedback	IQ/IQT actuator	AQ actuator	Q actuator
ESD	✓	✓	✓
Control Not Available	✓	✓	✓
Low Battery	✓	x	x
Stalled	✓	✓	✓
Handwheel	✓	✓	✓
Thermostat	✓	✓	✓

- ESD** Emergency shut down active. If the actuator receives an ESD signal from any source this signal will be true.
- Control Not Available** Otherwise known as the 'Monitor Relay'. The actuator includes a composite signal for some alarms referred to as the Monitor Relay. This signal will be set true if the actuator selector is in Local or Local Stop (not in Remote) or if the thermostat trips. In an IQ actuator the mains supply is also monitored and if any phase is lost the monitor relay bit is set. If a supply phase is lost communications with the actuator will also be lost if the actuator is single phase, or if the phase associated with the control circuits is lost on a three phase actuator.
- Low Battery** In the IQ and IQT actuator the status of the internal battery is monitored and should it fall below a critical level this signal will become true. The battery is used to power the circuits used to keep track of the valve position when the actuator mains power is switched off. This battery is used only when the actuator has no power feed and the valve is actually moved.
- Stalled** If the actuator is commanded to move and fails to do so within 4 seconds it is assumed that the motor has stalled. This signal will be present under those conditions.
- Handwheel** This signal is present if the actuator is moved manually by turning the handwheel. The motion needs to change the position by 1% or before it is detected.
- Thermostat** On electric actuators the motor is protected by a thermostat, if the temperature of the motor windings rises above the thermostat trip value, the thermostat contact will open and this signal will be present. There are no adjustments for the temperature at which the thermostat trip operates. The motor will be stopped if the thermostat trips. Only once the motor has cooled down and the thermostat has reset itself can a new Remote, Host or Local command to move the actuator Open or Closed be carried out. The ESD command may be set to override the thermostat. The bit will remain set at logic 1 until the motor cools down and the thermostat resets itself.

5.4 Analogue Feedback Data (Foundation)

The FF-01 module includes two Analogue Input blocks that are used to report data from the actuator. These blocks are connected to the Transducer block in the default configuration.

Analogue Feedback	IQ/IQT actuator	AQ actuator	Q actuator
Valve Position	✓	✓	✓
Actuator Torque Output	✓	✗	✗

- Valve Position** The valve position is reported through Analogue Input block AI1. The signal is ranged 0-100% where Close is 0% and Open 100% as reported by the 'end of travel' position limit switch settings.
- Actuator Torque** When fitted to an IQ or IQT actuator the module reports the instantaneous percentage torque value through the Analogue Input block AI2. The signal is ranged 0-120%.

5.5 Actuator Feedback Data (Hard Wired)

With each actuator, there can be feedback data available from the internal switches and relays that is independent of the Foundation network. In some installations, these signals are used in local indication panels to show the actuator status.

Status and Alarm Feedback	IQ/IQT actuator	AQ actuator	Q actuator
Monitor Relay	✓	✓	✓
Auxiliary Limit Switches OAS2/CAS2	✗	✓	✗
S1 to S4 settable switches	✓*	✗	✗

* Functions of S5 – S8 are fixed in IQ and IQT actuators.

Note: For full details of these signals refer to the wiring diagram supplied with the actuator.

- Monitor Relay** The actuator includes a composite signal for some alarms referred to as the Monitor Relay. This signal will be set true if the actuator selector is in Local or Local Stop (not in Remote) or if the thermostat trips. In an IQ actuator the mains supply is also monitored and if any phase is lost the monitor relay bit is set. If a supply phase is lost communications with the actuator will also be lost if the actuator is single phase, or if the phase associated with the control circuits is lost on a three phase actuator.
- Aux Limit Switches** Two additional adjustable limit switches can be included in the actuator to allow for external indication of valve position. These switches can be set anywhere in the valve's travel and are usually set for the open and closed position. These switches must be specified at time of order.

□ **S1 to S4**

The IQ/IQT actuator has configurable contact outputs. The logical four contacts S1 to S4 can be configured to make or break for one of the following functions and will be reported as true when made;

- Closed limit
- Open limit
- Intermediate position indication
- Torque trip in mid travel
- Actuator closing
- Actuator opening
- Actuator output rotating
- Motor stalled
- Battery low
- Hand operation
- Blinker
- Torque trip opening
- Torque trip closing
- Torque trip any position

Note: On ***IQ*** and ***IQT*** actuators the settings must be
S5 = Make at Torque Trip opening direction
S6 = Make at Torque Trip closing direction
S7 = Make at Torque Trip, mid travel
S8 = Don't care
S1 to S4 provide contact outputs from R1 to R4 and are directly configured in the actuator itself.
The output contacts available from R5 to R8 must be configured on the FF-01 module blocks DO5 to DO8

6 FUNCTION BLOCKS

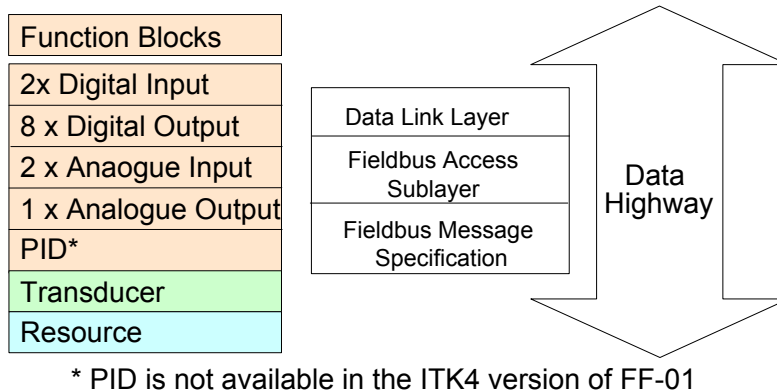

Fig 11: Function Blocks within the FF-01 module

Function blocks provide the heart of the Foundation Fieldbus system. Each device on a network includes at least one function block and a resource block to allow the equipment to be configured to operate on the network.

The ITK4 version of the FF-01 module includes 16 blocks, of which one is the Resource block and one is the Transducer block. The remaining 14 input and output blocks are used to control and collect data from the actuator.

In order to make the FF-01 easier to use many of the parameters in the blocks are already defined. Although they have default values assigned, a suitable configuration tool may alter some. Some of the network communications link location data (VCR codings) are already defined as required by the Foundation specifications. Publisher and Subscriber function blocks have VCR values assigned as described in the DD file. The pre-assigned connections that are fixed include:

- the allocation of the two AI blocks to the two analogue input variables in the actuator;
- the AO block to the resident analogue output positioner in the actuator
- the DO blocks to the digital outputs for controlling the open/close actions of the actuator

Many of the features of the function blocks are provided in order to allow the system to identify and use the blocks. The Fieldbus specification (FF-890 to FF-892) defines all aspects of the function blocks. In practice, the user needs to know very little about the internal workings of the blocks, as the Capabilities file list all the available features. A suitable configuration tool such as that supplied by SMAR or National Instruments is needed to set up all the tag names and operation of the blocks in the complete system. The contents of the blocks can also be examined using a configuration tool.

Each block has its own unique tag name allocated during system configuration.

Note: *The PID function is not available in the ITK4 version of the Rotork FF-01 Foundation Fieldbus card. It is available in the ITK3 version.*

6.1 Resource Block

Every device includes a resource block. This block contains data that is specific to the FF-01 itself. There are no links to this block and there is no function schematic. The block includes data such as the following, which is specific to the FF-01 module

Index	Parameter Mnemonic	FF-01 Value
10	MANUFAC_ID	65281
11	DEV_TYPE	1
12	DEV_REV	1
13	DD_REV	1
40*	ITK version	4

Note: *Parameter 40 is only included in the ITK4 version of the firmware, V1.10 or higher*

6.2 Analogue Input Blocks

The FF-01 includes two Analogue Input (AI) blocks.

- AI 1 Valve Current Position (analogue % value)**
The % open value (position) of the valve. The range is 0-100% and the end values relate to the close (0%) and open (100%) position limit switches.
- AI 2 Valve Current Torque Output (analogue % value) IQ only**
The instantaneous % torque value through the valve stroke. The range is 0-120%.

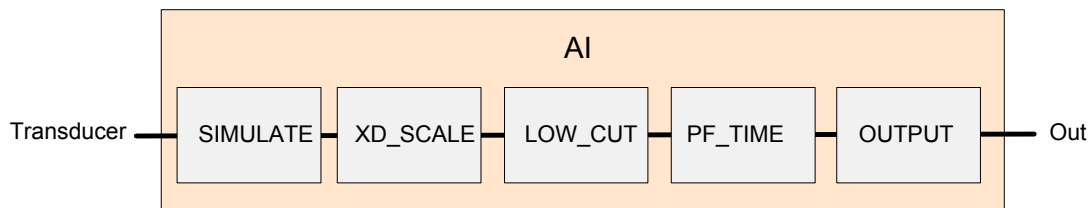

On installing the card the following settings will apply

- The block is instantiated on delivery of the module.
- The connections to the Transducer block are fixed and in place
- The Mode control is standard.
- The Alarms are disabled

Item	Description	Default Value
AI 1 and AI 2	Block Instantiation	Yes, instantiated
VCR	Outputs set to publish the values	Already Configured
PV	Output scaling	Set to XD_SCALE (linear)
CHANNEL	Channel 1 and 2	Ch1 = AI 1 = Position, Ch2 = AI 2 = Torque
LOW_CUT	Low cut off value	0%
PV_FTIME	Measurement filter time setting	0 seconds, (no filtering)
HI_HI_PRI through LO_LO_PRI	Alarm priority	All set to 0, no reporting
HI_HI_LIM, HI_LIM	High Alarm set points	High high = +INF, High = + INF
LO_LO_LIM, LO_LIM	Low Alarm set points	Low, low = -INF, Low = - INF

6.3 Digital Input Blocks

There are two Digital or Discrete Input Blocks (DI) included on the FF-01 module. These DI's may be configured to read back information from the valve codes listed in the Transducer Block.

- DI 1 Valve Code 0 to 39**
The input may be set to trigger from one of the valve codes 0-39 as listed in the section on the transducer block. For example DI1 can represent the valve fully open by linking its trigger event to code 9 in the list.
- DI 2 Valve Code 0 to 39**
The input may be set to trigger from one of the valve codes 0-39 as listed in the section on the transducer block. For example DI2 can represent the valve fully closed by linking its trigger event to code 10 in the list.

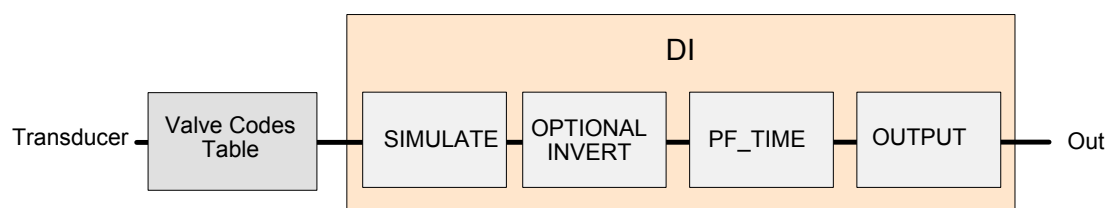

Fig 13: Digital Input Function Block

On installing the card the following settings will apply

- The block is instantiated on delivery of the module.
- The connections to the Transducer block are made through the 'Valve Codes' table
- DI 1 is set to Valve Code 33, 'Fail and ESD'

- DI 2 is set to Valve Code 34, 'Fail and Control Not Available'
- The Mode control is standard.
- The Alarms are disabled

Item	Description	Default Value
DI 1 and DI 2	Block Instantiation	Yes, instantiated
VCR	Outputs set to publish the values	Already Configured
CHANNEL	Channel 1 and Channel 2	DI 1 = Channel 1 = Valve code 33, DI 2 = Channel 2 = Valve code 34
PV_FTIME	Measurement filter time setting	0 seconds, (no filtering)

6.4 Analogue Output Block

There is one Analogue Output (AO) block in the FF-01 which is designed to allow the valve under control to be positioned to a specific value over its position range of 0-100%.

- A0 1** The % open value (position) of the valve. The range is 0-100% and the end values relate to the close (0%) and open (100%) position limit switches. Practical resolution is 1%.

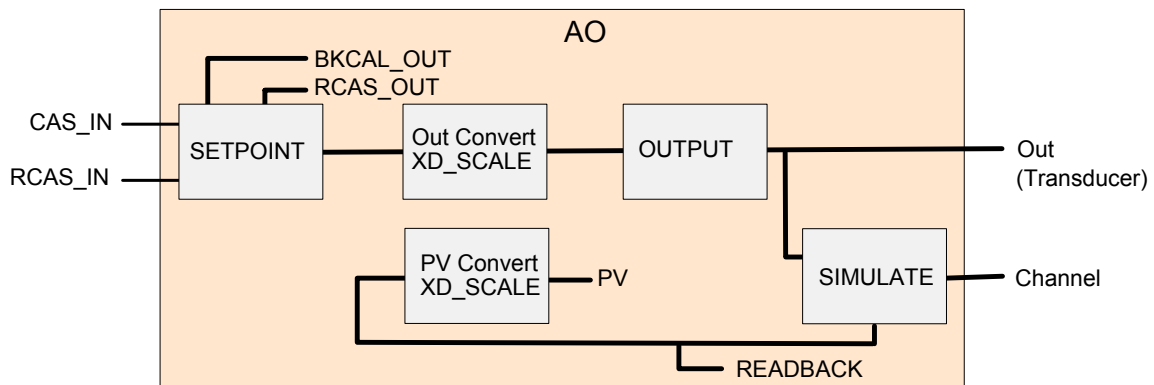

Fig 14: Analogue Output Function Block

On installing the card the following settings will apply

- The block is instantiated on delivery of the module.
- The output connections to the Transducer block are fixed and in place
- The Mode control is standard.
- The Alarms are disabled

Item	Description	Default Value
AO 1	Block Instantiation	Yes, instantiated
VCR	Inputs set to subscribe to values	Already Configured
SP	Output convert	Set to XD_SCALE (linear)
PV	PV convert	Set to XD_SCALE (linear)
SP Rate	SP_Rate_Dn and SP_Rate_Up	Both + INF
SP limits	SP_Hi_Lim, SP_Lo_Lim	High limit = 100% Low Limit = 0%
Scale	SP and PV and Readback	All 0-100%, 0% = closed

The AO block acts as a positioner for the valve and actuator. The positioning action is initiated by sending a new desired position to the input (usually the Cascade input). Repeating the previous position instruction will not cause the actuator to move. In order to initiate the position control algorithm the setpoint requested must differ between each instruction.

Note: *The positioning algorithm will only take effect if the digital inputs for controlling the valve are not present i.e. All set to Stop, and a position instruction is generated.*

Note: *If the actuator is sent to 50% by an AO command, followed by a DO to close and then requested to return to 50% it will remain closed. The AO setpoint must differ between commands to achieve a position output.*

6.5 Digital Output Blocks

There are 8 Digital Output (DO) blocks in the FF-01 which are designed to allow the valve under control in a discrete manner. In addition, for the IQ and IQT actuator the internal relays R5 to R8 may be controlled when the Relay Board option is fitted to the actuator. The DO channel to actuator function relationship is predefined by the connections to the Transducer block, but in the case of the open, stop and close commands these can effectively vary. The Transducer block contains a user variable setting for the Control Source. This determines if DO1 or DO2 alone, or both DO1 and DO2 channels will be used to drive the valve open and closed and also which value causes the operation.

- DO 1** The 'open' channel, depending on the mode selected this channel can totally control the valve.
- DO 2** The 'close channel, depending on the mode selected this channel can totally control the valve.

DO No. 1 and No. 2 have their action set in the Mode control in the Transducer block. These mode settings are explained below.

- DO 3** This channel is used to ESD the valve when the input is true
- DO 4** This channel is used for the Interlock input and has 4 possibilities
- DO 5 – DO 8** Applicable to IQ/IQT actuators, controls Relay 5 to 8 on the Relay Board

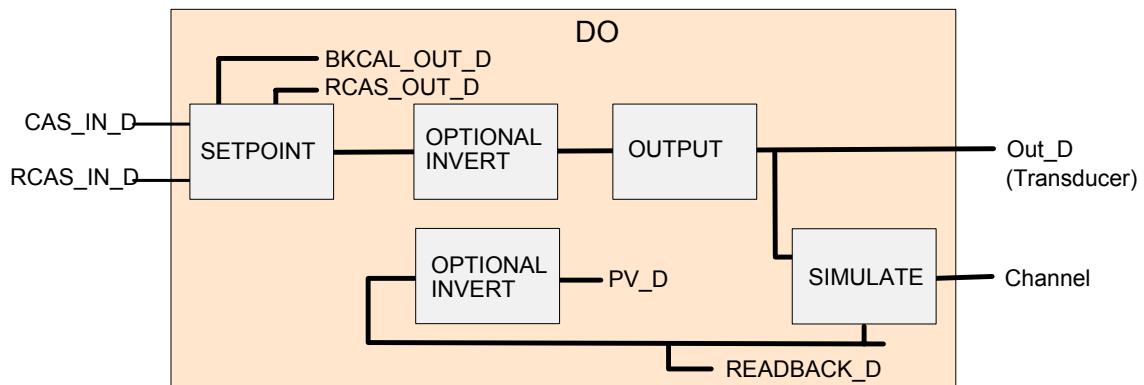

Fig 15: Digital Output Function Block

On installing the card the following settings will apply

- The blocks are instantiated on delivery of the module.
- The output connections to the Transducer block are fixed and in place
- The Mode control is standard.
- The Alarms are disabled
- The Control Source for DO1 and DO2 are set to Mono Discrete 3
- The inputs are inactive if not connected.

Item	Description	Default Value
DO 1 to DO 8	Block Instantiation	Yes, instantiated
VCR	Inputs set to subscribe to values	Already Configured
SP_D	Optional Invert	Set to no inversion
PV_D	Optional Invert	Set to no inversion

6.5.1 Control Source for DO1 and DO2

DO 1 and DO 2 are linked in the Transducer block to outputs described as 'open' and 'close'. These two channels used in combination or as individual channels control the full open, full close and stop discrete digital actions on the actuator. These DO digital signals always override any analogue AO signal unless the digital inputs are set to Stop in which case the AO signal, when refreshed by a new or repeated value will move the valve.

The Control Source is set up in the Transducer block for these outputs and has 7 possible settings. For each of these settings, the value written to the DO output will cause differing actions by the valve. In some cases, the action requires that both DO1 and DO2 are set correctly. When there is a conflict the priorities given in section 5 will be applied.

Control Source Setting	Action and Input to DO1 and DO2	
0 – None	Actuator Local and Hardwired Controls (no control from Fieldbus)	
1 – Mono Discrete 1	DO1 operates the valve, 0 = Stop, 1 = Open, 2 = Close	DO2 no action
2 – Mono Discrete 2	DO1 no action	DO2 operates the valve, 0 = Stop, 1 = Close, 2 = Open
3 – Dual Discrete	DO1 operates the valve, 0 = Stop, 1 = Open, 2 = Close (If one input is set to open and one to close the actuator will stop)	DO2 operates the valve, 0 = Stop, 1 = Close, 2 = Open
4 – Local	Actuator Local and Hardwired Controls (no control from Fieldbus)	
5 – Local Auxiliary	Actuator Local and Hardwired Controls (no control from Fieldbus)	
6 – Mono Discrete 3	DO1 operates the valve, 0 = Close, 1 = Open, 2 = Stop	DO2 no action
7 – Transducer Test	Not Used	

6.5.2 DO3, ESD Action

Input DO3 is used to operate the Fieldbus controlled ESD (Emergency Shut Down) action of the actuator. The action on receipt of this control is set in the actuator itself and may be Open, Close or Stay Put (do nothing). The connection between the Do block and the Transducer block is fixed and when the DO 3 input is true the actuator will perform the set ESD action.

Input to DO3	Description
0	No ESD via Fieldbus
1	ESD action invoked (as set in the actuator)

6.5.3 DO4, Interlock (AQ/Q only)

It is possible to set a permissive interlock that must be false before the actuator will respond to an input on DO1, DO2 or AO1. Whilst the interlock is any other value than zero the possible movement by any input source is restricted. In an IQ/IQT this action can be achieved by changing an output relay and wiring the contacts to the hard wired Interlock input. The Fieldbus DO4 must be set to '0' for no interlocking action.

Note: *The interlock control overrides the Local controls on the actuator*

Input to DO4	Action
0 – None	No interlock action (except the actuator hard wired interlocks where present)
1 – No Open	Interlock will prevent valve from opening
2 – No Close	Interlock will prevent valve from closing
3 – No Moving	Interlock will prevent valve from moving

6.5.4 DO5 to DO8, Relay R5 to R8 outputs (IQ/IQT only)

On the IQ/IQT actuator, when a Relay Board is fitted, the relays on that board can be controlled directly by the Fieldbus card. These are latching relays and will maintain the output contact status even when the power is removed from the actuator. Their status cannot be changed unless the actuator has power.

Input to DO5 – DO8	Action
0 – Reset	Relay contact will be opened and latched open
1 – Set	Relay contact will be closed and latched closed

6.6 PID Control Block – Not Available in ITK4 version 1.10 or higher

The actuator includes a standard three-term PID controller block for use in a control loop. The inputs and outputs of this block are not directly linked to the actuator Transducer block that means the PID controller can be used for controlling devices other than the actuator. With a PID function as long as an error exists between the set point (desired value) and the measured value feedback (process variable) the controller will change the output in a direction to reduce the error.

The way in which the output changes is influenced by the actual error value and the time it is present and the rate of change it undergoes. The PID settings applied Integrate the error with respect to time (RESET value), apply a proportional gain on the error (GAIN) and differentiate the rate of change in the error (RATE); all these actions are combined to produce the OUTPUT.

- PID** A stand-alone 3-term controller within the actuator.

On installing the card the following settings will apply

- The block is instantiated on delivery of the module.
- There are no connections to the Transducer block
- The Mode control is standard.
- The Alarms are disabled
- The controller is in Manual mode

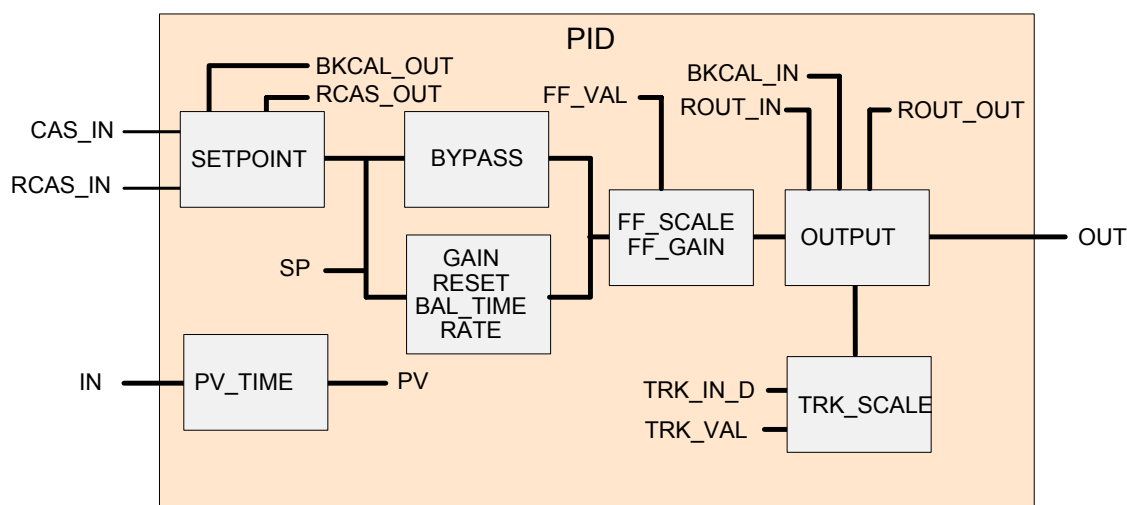

Fig 16: PID Function Block

Item	Description	Default Value
PID	Block Instantiation	Yes, instantiated
VCR	Inputs set to subscribe to values	Already Configured
PV	PV Filter	0 sec
GAIN	Control	0
RESET	Control	+ Inf
RATE	Control	0 sec
BAL-TIME	Control	0 sec
BYPASS	Bypass	Off
FF-SCALE	Feed forward	Eng. Units, 0-100%
FF-GAIN	Feed forward	0

The PID block must be connected and set up before it can be used. It is the only block in the FF-01 module that is not pre-connected to any input or output of the actuator transducer block and may be freely connected into a control loop. The scheduler is used to allocate a time slot for the control algorithm to execute.

6.7 Transducer Block

The transducer block is the heart of the function blocks in the FF-01 module. It provides all the connections to the actuator itself and contains within its parameters all the information about the Foundation device, commands and data feedback. Links between the hardware and block are already made to allow the user to access defined settings for the device.

Many of the links between the Transducer block and the Input/Output blocks are also defined and may not be altered. Data may be read from the parameters but not all parameters permit write commands. Writes are limited to the parameters used to set up the actuator control functions. The links between the DI blocks and the Transducer block are not totally defined and these inputs select a source signal from the valve status as reported in the tables within the Transducer block. These tables are referred to as the Valve Codes.

Some of the Transducer block parameters represent multiple conditions for the state of the actuator. In order to determine the value in these parameters a second list is provided to define them. This list is the Valve Codes list where multiple state conditions are described in a single parameter. The parameters that draw their reporting value from this list include the Digital Input block inputs, the Valve Status, the Stopping At and the Digital Output block source data for the relays in the IQ and IQT actuator. The tables give a full list of the available parameters and the Valve Codes.

On installing the card the following settings will apply

- The Transducer block is instantiated on delivery of the module.
- The default values in the table will apply
- The various settings must be made to allow control of the actuator

Table 1: Transducer Block Parameters

No	Parameter Mnemonic	Description	Valid Range	Initial Default Value	Units	Class
1	ST_REV	FF specific parameter	Positive	0	none	RO
2	TAG_DESC	FF specific parameter		Null	na	RW
3	STRATEGY	FF specific parameter		0	none	RW
4	ALERT_KEY	FF specific parameter	1 to 255	0	none	RW
5	MODE_BLK	FF specific parameter		O/S	na	RW
6	BLOCK_ERR	FF specific parameter				RO
7	UPDATE_EVT	FF specific parameter			na	RW
8	BLOCK_ALM	FF specific parameter			na	RO
9	TRANSDUCER_DIRECTORY	FF specific parameter			none	RO
10	TRANSDUCER_TYPE	FF specific parameter		100	E	RO
11	XD_ERROR	FF specific parameter		0	none	RO
12	COLLECTION_DIRECTORY	FF specific parameter			none	RO
13	CONTROL_SOURCE	Selects the Discrete output channel, DO1, DO2 or both, to open and close the valve Refer to the DO block description for details	0 – None 1 – Fieldbus - Mono Discrete Action 1 2 – Fieldbus - Mono Discrete Action 2 3 – Fieldbus - Dual Discrete Action 4 – Local 5 – Local Auxiliary 6 – Fieldbus - Mono Discrete Action 3 7 – Transducer test	2 (DO No 2 controls the actuator)	none	RW
14	FINAL_VALUE	AO 1 Analogue Output channel AO 1 Write value	0 to 100%		PVR	RO
15	FINAL_VALUE_RANGE		0 to 100%		PVR	RO
16	FINAL_VALUE_HYSTERESIS		0 to 100%	2	%	RW
17	FINAL_VALUE_DEADBAND		0 to 100%	2	%	RW
18	FINAL_VALUE_CUTOFF_HI		0 to +Inf	+Inf	FVR	RW
19	FINAL_VALUE_CUTOFF_LO		0 to -Inf	-Inf	FVR	RW
20	FINAL_POSITION_VALUE	Analogue Output channel AO 1 read back value	0 to 100%		%	RO
21	PRIMARY_VALUE_POSITION	AI 1 Analogue input AI No 1 (valve position) raw value	0 to 100%		%	RO
22	PRIMARY_VALUE_TORQUE	AI 2 Analogue input AI No 2 (torque) raw value	0 to 120%		%	RO
23	PRIMARY_VALUE_TEMPERATURE	Actuator Internal Ambient temperature (No Analogue input channel connected)	0 to 100°C	0	°C	RO

No	Parameter Mnemonic	Description	Valid Range	Initial Default Value	Units	Class
24	OPEN_FINAL_VALUE_D DO 1	Discrete Output channel DO 1 value	Mono 1 0 – Stop 1 – Open 2 – Close Mono 3 0 – Close 1 – Open 2 – Stop	0	none	RO
25	OPEN_LOCAL_FINAL_VALUE_D	Discrete Output channel DO 1 Read back	Mono 1 0 – Stop 1 – Open 2 – Close Mono 3 0 – Close 1 – Open 2 – Stop	0	none	RO
26	CLOSE_FINAL_VALUE_D DO 2	Discrete Output channel DO 2 value	Mono 2 or 3 0 – Stop 1 – Open 2 – Close	2	none	RO
27	CLOSE_LOCAL_FINAL_VALUE_D	Discrete Output channel DO 2 Read back	Mono 2 or 3 0 – Stop 1 – Open 2 – Close	2	none	RO
28	FINAL_POSITION_VALUE_D	Current Actuator Open/Close command	0 – Stop 1 – Open 2 – Close	0	none	RO
29	PRIMARY_VALUE_D_1_SOURCE	Selectable Internal Value event to set Discrete Input channel DI 1 active	Valve Code Index 0 to 39	32	none	RW
30	PRIMARY_VALUE_D_1 DI 1	Discrete Input channel DI 1 value	0 – Inactive (false) 1 – Active (true)	0	none	RO
31	PRIMARY_VALUE_D_2_SOURCE	Selectable Internal Value event to set Discrete Input channel DI 2 active	Valve Code Index 0 to 39	33	none	RW
32	PRIMARY_VALUE_D_2 DI 2	Discrete Input channel DI 2 value	0 – Inactive (false) 1 – Active (true)	0	none	RO
33	ACT_FAIL_ACTION	Actuator action on loss of communications signal	0 – Stop 1 – Close 2 – Open 3 – Stay at last position	0	none	RW
34	ACT_MAN_ID	FF specific parameter		0	E	RO
35	ACT_MODEL_NUM	FF specific parameter		Null	none	RW
36	ACT_SN	FF specific parameter		Null	none	RW
37	VALVE_MAN_ID	FF specific parameter		0	none	RW
38	VALVE_MODEL_NUM	FF specific parameter		Null	none	RW
39	VALVE_SN	FF specific parameter		0	none	RW
40	VALVE_TYPE	FF specific parameter		0	none	RW
41	XD_CAL_LOC	FF specific parameter		Null	none	RW
42	XD_CAL_DATE	FF specific parameter		0	none	RW
43	XD_CAL_WHO	FF specific parameter		Null	none	RW
44	ESD_FINAL_VALUE_D DO 3	Discrete Output channel DO 3 value	0 – Inactive (false) 1 – Active (true)	0	none	RO
45	ESD_LOCAL_FINAL_VALUE_D	Discrete Output channel DO 3 Read back	0 – Inactive (false) 1 – Active (true)	0	none	RO
46	ESD_FINAL_POSITION_VALUE_D	Actual ESD condition inclusive of hardwired ESD input	0 – Inactive (false) 1 – Active (true)	0	none	RO
47	ILOCK_FINAL_VALUE_D DO 4	Discrete Output Channel DO 4 value	0 – No Interlock 1 – Inhibit Opening 2 – Inhibit Closing 3 – Inhibit Moving	3	none	RO

No	Parameter Mnemonic	Description	Valid Range	Initial Default Value	Units	Class
48	ILOCK_LOCAL_FINAL_VALUE_D	Discrete Output Channel DO 4 Read back	0 – No Interlock 1 – Inhibit Opening 2 – Inhibit Closing 3 – Inhibit Moving	3	none	RO
49	ILOCK_FINAL_POSITION_VALUE_D	Actual Interlock condition inclusive of hardwired Interlock Inputs	0 – No Interlock 1 – Opening Inhibited 2 – Closing Inhibited 3 – Moving Inhibited	3	none	RO
50	VALVE_STATUS	Valve and actuator condition indication	Valve Code Index 4, 15,16, or Index 33 to 39		none	RO
51	INHIBITING_TIMER	Actuator Motion Inhibit Time (used in positioning)	0 to 255	0	Sec	R/W
52	STOPPING_AT	Actuator position and motion indication	Valve Code Index 0 to 3 or Index 5 to 14	0	none	RO
53	RELAYS_SOURCE	Fieldbus (DO Block) or internal actuator event selector (Each relay source may be selected independently)	0 – Actuator controlled 1 – Fieldbus controlled	0	none	RW
54	RELAYS_TRIGGER	Internal actuator event selection. (Each relay trigger may be selected independently)	Valve Code Index 0 to 39	0	none	RW
55	RELAY5_FINAL_VALUE_D DO 5	Discrete Output Channel DO 5 value	0 – Reset 1 – Set	0	none	RO
56	RELAY6_FINAL_VALUE_D DO 6	Discrete Output Channel DO 6 value	0 – Reset 1 – Set	0	none	RO
57	RELAY7_FINAL_VALUE_D DO 7	Discrete Output Channel DO 7 value	0 – Reset 1 – Set	0	none	RO
58	RELAY8_FINAL_VALUE_D DO 8	Discrete Output Channel DO 8 value	0 – Reset 1 – Set	0	none	RO
59	RELAYS_VIEW	Current state of relays (independently viewed)	Relay 5 to 8 0 – Reset 1 – Set	0	none	RO
60	AUX_FUNCTION	Control state of hardwired actuator inputs. Monitor the input or control the actuator (Each input may be independently set)	Aux 1 (Open) Aux 2 (Close) Aux 3 (Stop/maintain) Aux 4 (ESD) Setting: 0 – Monitor 1 – Control	0	none	RW
61	AUX_VIEW	Hardwired input current state for Aux 1 to 4	Aux 1 to Aux 4 Condition: 0 – Inactive (false) 1 – Active (true)	0	none	RO
62	ACTUATOR_CONTROL_STATE	Local Control selector position report	0 – Local 1 – Local Stop 2 – Remote		none	RO

The Parameter Mnemonic will appear in the Configuration Tool being used to set up the module. The following explains the function of the Rotork specific parameters. References to Local refer to the actuator local control knobs whilst references to Auxiliary inputs refer to the hard-wired contacts taken to the actuator terminals. Not all the parameters are applicable to all the actuator types. Only IQ and IQT actuators have the ability to use AI 2, the Torque reading, and the four relays DO 5 to DO 8.

□ 13 – CONTROL_SOURCE

The actuator may be controlled from a number of alternate sources, DO1, DO2, or AO1 or the local controls and hard wired inputs. If digital control DO1 and DO2 or just DO1 or DO2 are to be used then this parameter must be set correctly to select

the source. The list of choices includes some settings which are not applicable to actuators and the actuator local controls and hard wired inputs are always available for control (provided the hard wired inputs are set for 'control' and not 'monitoring'). When analogue control is used, the digital control must be set to Stop to allow the new desired position command to be active. A new digital command will remove the actuator from analogue control. The section on DO blocks describes the DO codes needed to move the actuator in a particular direction. It is necessary to set up the CONTROL_SOURCE as well as direct the correct command to the DO block to control the actuator digitally.

Value	Name	Foundation	Remote hardwired	Local Controls
0	None	Digital and Analogue commands will not move the actuator	Enabled	Enabled
1	Mono Discrete 1	DO1 operates the actuator	Enabled	Enabled
2	Mono Discrete 2	DO2 operates the actuator	Enabled	Enabled
3	Dual Discrete	DO1 and DO2 operate the actuator	Enabled	Enabled
4	Local	Commands will not move the actuator	Enabled	Enabled
5	Local Auxiliary	Commands will not move the actuator	Enabled	Enabled
6	Mono Discrete 3	DO1 operates the actuator	Enabled	Enabled
7	Transducer Test	Commands will not move the actuator	Enabled	Enabled

- 14 – FINAL_VALUE (AO1)**
The current value of the valve desired analogue position may be read from this Read Only parameter.
- 15 – FINAL_VALUE_RANGE**
The analogue output signal is ranged 0-100%. This parameter may not be altered.
- 16 – FINAL_VALUE_HYSTERESIS**
See also Parameter 17 and Parameter 51.
The position controller in the actuator that is used to move the valve to an analogue position includes a hysteresis setting that, in combination with the deadband, prevents hunting when positioning the actuator. The value of hysteresis is set here. Hysteresis acts differently to deadband in that the hysteresis control acts on the edge of the deadband. The controller will run the actuator towards the setpoint, stopping the motor when the position is inside the deadband by an amount equal to the hysteresis. The motor will not restart until the deadband is exceeded.
- 17 – FINAL_VALUE_DEADBAND**
See also Parameter 16 and Parameter 51
The position controller in the actuator runs the actuator in a direction towards the analogue setpoint, then stops the actuator. Because of the valve and actuator inertia there is a possibility that the desired position may be overrun and the

controller will then reverse the direction to return to the setpoint. This is known as hunting and the actuator may hunt around the control point if the inertia is high. To prevent this from happening the actuator has three adjustable settings, Deadband, Hysteresis (see parameter 16) and Inhibiting Timer (see parameter 51). The deadband setting is the amount by which the actuator and valve must overrun the setpoint before it is reversed. The motor will be stopped once the position approaches the setpoint nearer than the deadband value minus the hysteresis setting. The motor will restart if the overshoot is sufficient to make the position deviate from the setpoint by an amount greater than the deadband alone.

- 18 – FINAL_VALUE_CUTOFF_HI**
- 19 – FINAL_VALUE_CUTOFF_LO**
These parameters should not be adjusted. They do not affect the actuator operation.
- 20 – FINAL_POSITION_VALUE**
Read back parameter showing the actual value sent as the setpoint for the valve position controller.
- 21 – PRIMARY_VALUE_POSITION (AI1)**
Read only parameter giving the valve position.
- 22 – PRIMARY_VALUE_TORQUE (AI2)**
Read only parameter giving the current valve torque. This value latches when the motor stops to show the last value read before the motor stopped.
- 23 – PRIMARY_VALUE_TEMPERATURE**
Read only parameter from which the actuator internal temperature can be read. (Note that this is not linked to an Analogue Input channel)
- 24- OPEN_FINAL_VALUE_D (DO1)**
This parameter can be read to determine the current control action on the output of DO1. The action will depend on the setting of the CONTROL_SOURCE parameter.
- 25 – OPEN_LOCAL_FINAL_VALUE_D**
This is the read back parameter for DO1 from the transducer block. The action will depend on the setting of the CONTROL_SOURCE parameter.
- 26 - CLOSE_FINAL_VALUE_D (DO2)**
This parameter can be read to determine the current control action on the output of DO2. The action will depend on the setting of the CONTROL_SOURCE parameter.
- 27 – CLOSE_LOCAL_FINAL_VALUE_D**
This is the read back parameter for DO2 from the Transducer block. The action will depend on the setting of the CONTROL_SOURCE parameter.
- 28 – FINAL_POSITION_VALUE_D**
Once the Transducer block has determined the action to take depending on the values of DO1 and DO2 and the CONTROL_SOURCE parameter a value is placed

in this parameter of the actual demand on the actuator. This value also becomes the read back for DO1 and DO2.

- 29 – PRIMARY_VALUE_D_1_SOURCE**
Write to this parameter to select a Valve Code Index to be fed back by DI1. The chosen Valve Code Index will be shown in this parameter.
- 30 – PRIMARY_VALUE_D_1 (DI1)**
For the Valve Code Index selected this parameter shows if the status of the code is true or false and hence if the actuator is in the selected state or not.
- 31 – PRIMARY_VALUE_D_2_SOURCE**
Write to this parameter to select a Valve Code Index to be fed back by DI2. The chosen Valve Code Index will be shown in this parameter.
- 32 – PRIMARY_VALUE_D_2 (DI2)**
For the Valve Code Index selected this parameter shows if the status of the code is true or false and hence if the actuator is in the selected state or not.
- 33 – ACT_FAIL_ACTION**
The actuator can react itself to the loss of communication on the Foundation highway. If no activity is detected the actuator may stop, close, open or remain in its last position. The value written to this parameter determines the action taken. If Option 3, Stay in Last Position is selected the actuator will complete any current in progress. Local controls remain active when communications are absent.
- 44 – ESD_FINAL_VALUE_D (DO3)**
This parameter can be read to determine the current control action on the output of DO3. The action will depend on the setting of the actuator for an ESD input.
- 45 – ESD_LOCAL_FINAL_VALUE_D**
This is the read back parameter for DO3 from the transducer block. The action will depend on the setting of the actuator for an ESD input.
- 46 – ESD_FINAL_POSITION_VALUE_D**
This parameter gives the actual condition of the actuator ESD signal, including the ESD signal from a hard-wired remote input as well as from the Foundation highway.
- 47 – ILOCK_FINAL_VALUE_D (DO4)**
This parameter can be read to determine the current control action on the output of the Interlock signal, DO4. If there is no interlock required DO4 must be set to zero.
- 48 – ILOCK_LOCAL_FINAL_VALUE_D**
This is the read back parameter for DO4 from the Transducer block. The action will depend on the setting of DO4.

- 49 – ILOCK_FINAL_POSITION_VALUE_D**
This parameter gives the actual condition of the actuator Interlock signal, or for the IQ/IQT, the Interlock signal from a hard-wired remote input as well as from the Foundation highway.
- 50 – VALVE_STATUS**
This parameter allows the valve status with respect to the availability for control to be examined. The value reported will be taken from the Valve Code list and will be one of Index 4, index 16 or Index 33 to 39. If the condition of the actuator satisfies more than one of the codes then the condition with the highest Index will be reported. As the conditions changes the reported data will change. If the
- 51 – INHIBITING_TIMER**
See also parameter 16 and parameter 17
The position controller in the actuator includes a setting to protect the motor from exceeding the rated starts per hour and also assist in stabilising the process and setpoint. Every time the actuator stops it will remain stationary for a period equal to the Inhibiting Timer setting value set in this parameter.
- 52 – STOPPING_AT**
This parameter allows the valve position (open, closed, moving etc.) to be examined. The value reported will be taken from the Valve Code list and will be one of Index 3 or Index 5 to 16. If the condition of the actuator satisfies more than one of the codes then the condition with the highest index will be reported. As the conditions changes the reported data will change.
- 53 – RELAYS_SOURCE**
Applicable to IQ/IQT actuators only - the operation of the actuator relays 5 to 8 may be selected from one of the Valve Codes (Actuator) or from another function block or other signal through the DO block itself (Foundation). The choice between Foundation or Internal control for each relay is made using this parameter.
- 54 – RELAYS_TRIGGER**
IQ/IQT only - When the relay has been chosen to be activated by an Actuator condition this parameter is used to select, for each relay, the Valve Code state that will cause the relay to operate.
- 55 – RELAYS_FINAL_VALUE_D (DO5)**
IQ/IQT only – Shows the current state of Relay 5
- 56 – RELAYS_FINAL_VALUE_D (DO6)**
IQ/IQT only – Shows the current state of Relay 6
- 57 – RELAYS_FINAL_VALUE_D (DO7)**
IQ/IQT only – Shows the current state of Relay 7
- 58 – RELAYS_FINAL_VALUE_D (DO8)**
IQ/IQT only – Shows the current state of Relay 8

- ❑ **59 _ RELAYS_VIEW**
This parameter allows the status of each of Relays 5 to 8 to be viewed individually.
- ❑ **60 – AUX_FUNCTION**
The actuator can accept remote hardwired contact inputs that may be used for controlling the actuator position (Open, Closed, Stop, or ESD) or to report field data such as a level switch or pressure switch contact state. This parameter allows (for each of the four remote inputs) the action of these inputs to be set. It can be either 'Monitor' which simply reports the input status or 'Control' which reports the status and also controls the actuator.
- ❑ **61 - AUX_VIEW**
This parameter allows the state of the four hard-wired inputs to be examined.
- ❑ **62 – (FUTURE) ACTUATOR_CONTROL_STATE**
The Local/Local Stop/Remote selector on the actuator must be in the Remote position for the Foundation inputs to control the actuator. This parameter directly reports the condition of the selector.

6.7.1 Valve Codes

In determining the condition of the actuator or connecting function blocks to various actuator states (open, closed, moving etc.) the condition is reported in various parameters in the Transducer Block. Some of these parameters directly reflect a single actuator condition as true or false whilst others have multiple conditions. These multiple conditions are found in a table or list that comes from the Valve Codes. The Valve Codes are a list of the possible conditions the actuator. If the actuator condition satisfies more than one of the codes, for example Moving and Moving Open then the Transducer parameter reporting the code will report the one with the higher index. If the parameter has a limited range of codes to report and none are true it will report a code from lower in the table that is true.

Some of the possible codes are not used and some are allocated for internal use in the actuator. Some of the codes are not available from AQ and Q actuators. Table 2 gives a full list of the Valve Codes and a description of them follows.

Table 2 – Valve Codes

Valve Code No.	Identifier message	Available as Trigger Event	Description	Applicable Actuator Type
00	STOP	Y	Stationary in Mid Travel or Local/Stop/Remote selector in Stop position	All
01	OPEN	Y	Open and Open Limit switch or Open Torque switch true, or actuator moving in open direction	All
02	CLOSE	Y	Closed and Close Limit switch or Closed Torque switch true, or actuator moving in closed direction	All
03	Motion Inhibited	Y	Motion Inhibit Timer Running	All
04	LOCAL OVERRIDE	Y	Local/Stop/Remote selector in Local or Stop position	All
05	Position Achieved	Y	(assigned to actuator stationary at desired position)	All
06	Torque Limit Achieved	Y	(assigned to at desired position and stopped on torque)	IQ/IQT
07	Moving	Y	Actuator in motion either opening or closing	All

Valve Code No.	Identifier message	Available as Trigger Event	Description	Applicable Actuator Type
08	Stopped at Position Mid	N	(assigned to stopped in mid-travel at desired position)	NA
09	Opened at Position Lim	Y	Valve Open Limit Switch reached	All
10	Closed at Position Lim	Y	Valve Closed Limit Switch reached	All
11	Opened at Torque Lim	Y	Valve Open and opening Torque Switch tripped	IQ/IQT
12	Closed at Torque Lim	Y	Valve Closed and closing Torque Switch tripped	IQ/IQT
13	Opening	Y	Travelling in Open Direction	All
14	Closing	Y	Travelling in Close Direction	All
15	STOP and LOCAL OVERRIDE	Y	Local/Stop/Remote selector in Local Stop position	All
16	Fail and Stopped at Position Mid and at Torque Lim	N	Valve Obstructed (actuator stopped in mid-travel and torque switch tripped)	IQ/IQT
17	Xcode not defined	N	Reserved	NA
18	Xcode nor defined	N	Reserved	NA
19	Aux Input 1	Y	Auxiliary Input 1 Active	All
20	Aux Input 2	Y	Auxiliary Input 2 Active	All
21	Aux Input 3	Y	Auxiliary Input 3 Active	All
22	Aux Input 4	Y	Auxiliary Input 4 Active	All
23	Interrupted Timer	Y	Interrupter Timer Running	IQ/IQT
24	Blinker	Y	Blinker On	IQ/IQT
25	Interlock	Y	Interlock Active (electrical movement not permitted)	All
26	Xcode not defined	N	Reserved	NA
27	Interlock and None	Y	(assigned to interlock active and mid travel position)	All
28	Interlock and OPEN	Y	(assigned to interlock active and actuator open command received, valve cannot be opened)	All
29	Interlock and CLOSE	Y	(assigned to interlock active and actuator close command receive, valve cannot be closed)	All
30	Interlock and Both	Y	(assigned to interlock active and actuator cannot be opened or closed)	All
31	Xcode not defined	N	Reserved	NA
32	Xcode not defined	N	Reserved	NA
33	FAIL and ESD	Y	ESD Command Issued	All
34	FAIL and control not available	N	Monitor Relay (Local, Local Stop, or Thermostat tripped) active	NA
35	FAIL and Battery Low	Y	Low Battery	IQ/IQT
36	FAIL and Stalled	Y	Valve Jammed	IQ/IQT
37	FAIL and Handwheel moving	Y	Manual Movement Detected	All
38	FAIL and Hot	Y	Thermostat Trip	All
39	FAIL and Maintain	N	Not implemented as trigger event	NA
40	SAVING EEPROM	N	Not implemented as trigger event	NA
41	BATTERY LOW & CONTROL_NOT_AVAILABLE	N	(Battery Low and Control Not Available)	Future
42	STALLED & CONTROL_NOT_AVAILABLE	N	(Stalled and Control Not Available)	Future
43	STALLED & BATTERY LOW & CONTROL_NOT_AVAILABLE	N	(Stalled, Battery Low and Control Not Available)	Future
44	HANDWHEEL & CONTROL_NOT_AVAILABLE	N	(Hand Operation and Control Not Available)	Future
45	HANDWHEEL & LOW BATTERY	N	(Hand Operation and Battery Low)	Future
46	HANDWHEEL & LOW BATTERY & CONTROL_NOT_AVAILABLE	N	(Hand Operation, Battery Low and Control Not Available)	Future
47	HOT & CONTROL_NOT_AVAILABLE	N	(Thermostat Tripped and Control Not Available)	Future
48	HOT & BATTERY LOW	N	(Thermostat Tripped and Battery Low)	Future
49	HOT & LOW & CONTROL_NOT_AVAILABLE	N	(Thermostat Tripped and Control Not Available)	Future

Valve Code No.	Identifier message	Available as Trigger Event	Description	Applicable Actuator Type
50	HOT & STALLED	N	(Thermostat Tripped and Stalled)	Future
51	HOT & STALLED & CONTROL_NOT_AVAILABLE	N	(Thermostat Tripped and Stalled and Control Not Available)	Future
52	HOT & STALLED & LOW BATTERY	N	(Thermostat Tripped and Battery Low)	Future
53	HOT & STALLED & LOW BATTERY & CONTROL_NOT_AVAILABLE	N	(Thermostat Tripped and Battery Low and Control Not Available)	Future
54	HOT & HANDWHEEL	N	(Thermostat Tripped and Hand Operation)	Future
55	HOT & HANDWHEEL & CONTROL_NOT_AVAILABLE	N	(Thermostat Tripped and Hand Operation and Control Not Available)	Future
56	HOT & HANDWHEEL & BATTERY LOW	N	(Thermostat Tripped and Hand Operation and Battery Low)	Future
57	HOT & HANDWHEEL & BATTERY LOW & CONTROL_NOT_AVAILABLE	N	(Thermostat Tripped and Hand Operation and Control Not Available)	Future

- Code 00 – STOP**
This code indicates that the actuator Local/Stop/Remote selector is in the 'Stop' position, or that the actuator has stopped in mid-travel.
- Code 01 – OPEN**
This code indicates that the valve is in the fully open position or travelling in the open direction. The open position is detected by the limit switch setting or the torque switch depending on the type of valve and the actuator setting.
- Code 02 – CLOSE**
Similar to the OPEN indication this code indicates that the valve is in the fully closed position or travelling in the closed direction. The closed position is detected by the limit switch setting or the torque switch depending on the type of valve and the actuator setting.
- Code 03 – Motion Inhibited**
This code indicates that the actuator motor has stopped during a valve analogue positioning action whilst the Motion Inhibit Timer is running. This timer is used to ensure that the motor does not exceed its rated number of starts per hour. In practice, it will most likely be the delay seen during positioning when the actuator has overrun the desired position and needs to reverse direction to come back to the desired set point.
- Code 04 – LOCAL OVERRIDE**
When the Local/Stop/Remote selector is in either the Local or Stop position this code will be valid.
- Code 07 – Moving**
If the actuator is moving due to either motor action or hand action this code will be true.

- Code 09 – Open at Position Lim**
When the actuator reaches the Open limit switch due to an open command, a 100% position command, is manually opened by the hand wheel, opened by the local controls, or by a remote hardwired input this code will be true.
- Code 10 – Closed at Position Lim**
When the actuator reaches the Closed limit switch due to a close command, a 0% position command, is manually closed by the hand wheel, closed by the local controls, or by a remote hardwired input this code will be true.
- Code 11 – Opened at Torque Lim**
When the actuator reaches the Open torque trip switch due to an open command, a 100% position command, or is manually opened by the hand wheel, opened by the local controls, or by a remote hardwired input and the torque setting is reached or exceeded this code will be true.
- Code 12 – Closed at Torque Lim**
When the actuator reaches the Closed torque trip switch due to a close command, a 0% position command, is manually closed by the hand wheel, closed by the local controls, or by a remote hardwired input and the torque setting is reached or exceeded this code will be true.
- Code 13 - Opening**
When the actuator is travelling in the open direction by motor or hand operation this code will be true.
- Code 14 - Closing**
When the actuator is travelling in the close direction by motor or hand operation this code will be true.
- Code 15 – STOP and LOCAL OVERRIDE**
This code indicates that the actuator Local/Stop/Remote selector is in the 'Stop' position and that control over the Foundation link is not possible.
- Code 16 – Fail and Stopped at Position Mid and at Torque Lim**
When the valve is jammed due to an obstruction it will torque trip in mid stroke and stop moving. It will be necessary to reverse the direction of travel to release the jam. When these conditions are met the code is true.
- Code 19 to Code 22 – Aux 1 Input to Aux 4 Input**
When the hard-wired inputs are active the appropriate input code will be set on these bits.
- Code 23 – Interrupted Timer**
In an IQ or IQT when the Interrupter Timer (as used to slow down the speed of travel) halts the motion of the actuator this code will be true.
- Code 24 – Blinker**
The IQ and IQT include a 'flasher' signal, this code follows the state of the flasher, true when the flasher output is on.

- Code 25 – Interlock**
If the Interlock output (DO4) is active then this code will be true. Note that if the interlock is active then the local controls do not operate.
- Code 27 – Interlock and None**
When the valve is in a mid position and the interlock (DO4) is set to prevent moving (both opening and closing) this code will be true if a command to move the actuator is issued.
- Code 28 – Interlock and Open**
When the valve is open and the interlock (DO4) is set to prevent it from closing this code will be active if a close command is present.
- Code 29 – Interlock and Close**
When the valve is closed and the interlock (DO4) is set to prevent it from opening this code will be active if an open command is present.
- Code 30 – Interlock and Both**
When the valve is at either end of travel and the interlock (DO4) is set to prevent moving (both opening and closing) this code will be true if a command to move the actuator is issued.
- Code 33 – Fail and ESD**
When a command is sent to the actuator, but it is in ESD mode this code will be true. The command will be rejected because the ESD is present and take priority.
- Code 35 – Fail and Battery Low**
In an IQ if the Battery voltage falls below a critical level this code will be true.
- Code 36 – Fail and Stalled**
When the actuator encounters an obstruction in mid travel the torque trip mechanism will operate and stop the actuator. This code will be true.
- Code 37 – Fail and Handwheel moving**
If the actuator is moved by means of the handwheel this code will be true.
- Code 38 – Fail and Hot**
If the motor thermostat trips this code will be true, the thermostat can trip on a modulating duty if the rated number of starts per hour is exceeded. Setting the motion inhibit timer (Parameter 51) to a longer period will overcome this.

(This page is intentionally blank)

7 LINK ACTIVE SCHEDULER

Foundation devices may be either Basic or Link Master devices. Basic units do not have the ability to hold the timing schedule for scanning the nodes and cannot act as system controllers. Every network requires at least one Link Master to control the network communications. A Link Master that is in control of the communications is known as a Link Active Scheduler.

All FF-01 modules are capable of acting as Link Masters and assuming network control by switching automatically to become the Link Active Scheduler. The default value is for the unit to be in Basic mode and the Link Master option must be switched on during system configuration. As many as are required can be switched to this mode since only one will become the active device at any one time.

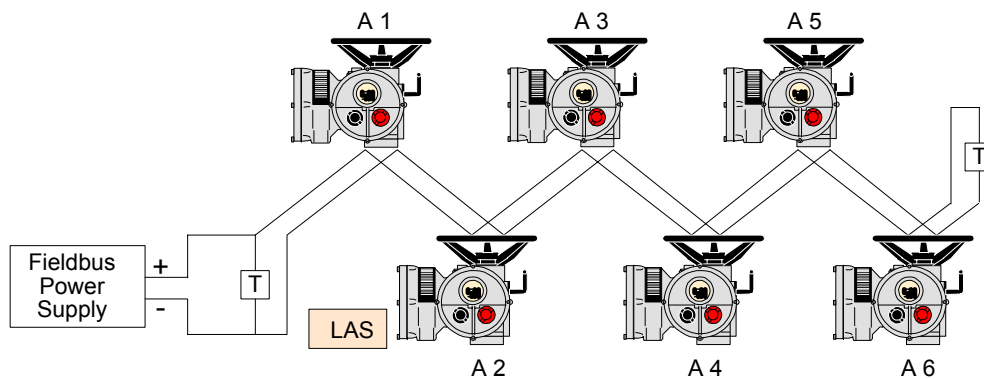

Fig 17: Link Active Scheduler – one per network

In order to change the FF-01 from a Basic unit to a Link Master a suitable configuration tool or dialogue tool must be used. The setting is contained in the Management Information Base and the data must first be opened using the dialogue tool.

The parameter to be altered resides in the MIB type of VFD. The class is called

`BOOT_OPERAT_FUNCTIONAL_CLASS`

This class can have two values,

01 = Basic Unit
02 = Link Master

Edit the value and download the setting to obtain the desired function. Units are shipped as 'Basic' modules.

The type of function available can also be read in the parameter

`DLME_BASIC_CHARACTERISTICS`

then the class `DL_OPERAT_FUNCTIONAL_DEVICE_CLASS`

a value of 1 indicates a basic unit whilst a 2 indicates a Link Master.

Once the type has been selected the configuration tool can be used to download the system configuration. The schedule will reside in all the Link Masters and be executed by the one that is active, the Link Active Scheduler. Should the LAS fail then any of the remaining Link Master units is able to take the role of LAS.

When a system is being configured the Rotork devices on the network must be connected to the bus after the configuration tool is started unless the devices are in Basic mode. If they are in Link Master mode then the first one connected will become the LAS and the configuration tool will be unable to gain full network control.

7.1 Creating a Schedule

Once a control strategy has been worked out the individual function blocks distributed across the network have to be interconnected using a suitable configuration tool. The configuration process also includes formatting the schedule for the execution of the function blocks. Many configuration tools include the facility to create and alter the schedule, which is downloaded to the system during the system download.

The individual function blocks each require a time slice of the total execution cycle in which to operate. The execution times required for each block in the FF-01 module are as indicated in the table. The data from the Transducer block does not need to be included in the schedule as it is recovered during the probe node and compel data cycles of the Link Active Scheduler.

If the DI blocks are connected to trigger events in the Transducer block on the same actuator they have a minimal execution time.

Function Block	Execution Time (mSec)
Analogue Input (AI)	34
Analogue Output (AO)	30
Digital Input (DI)	30
Digital Output (DO)	34
Controller (PID)	67

Make sure when creating a schedule that there are sufficient time gaps between the cycles to allow the routine background tasks to perform correctly.

7.2 Connecting the Blocks

The function blocks used to execute the control strategy must be connected together as well as configured to the Transducer block. The interconnection of the blocks requires the use of a suitable Configuration tool. Such devices can be purchased from SMAR or National Instruments.

Since all the function blocks are instantiated on delivery there is no need to instantiate them when a control scheme is designed.

8. SETTING UP THE FF-01 MODULE

When setting up the actuator to use the Foundation Fieldbus control there are a number of parameters in the **Transducer block** that must be set to match the control system requirements. The method of Foundation control of the actuator can be

- Digital using Open/Stop/Close commands,
- Analogue using a position demand setpoint
- Mixed using digital and positioning commands

The hard-wired inputs can be used for either monitoring or control

- Hard-wired inputs monitor contact feedback signals
- Hard-wired inputs control the actuator directly

The Foundation DI digital input blocks can report data from the values in the valve codes list.

- Digital Input (DI) selected from the valve codes

The condition of the actuator can be viewed by selecting the correct parameter.

- Valve Status gives the valve condition
- Stopping At gives the valve position (digital)
- Primary Value Position gives the actual analogue position

Note: *the valve must be moved from fully closed to fully open with the fieldbus and actuator power applied in order to scale this value correctly.*

8.1 Setting Digital Control

The Transducer block parameter 'CONTROL_SOURCE' has to be set to a value suitable for the control system to use. The three actuator commands (Open/Stop/Close) can be generated from one or two DO blocks depending on the mode of control chosen. The 'mode' has four choices that affect the Foundation control, Mono Discrete 1, Mono Discrete 2, Dual Discrete or Mono Discrete 3.

CONTROL_SOURCE				
Value	Name	Foundation	Discrete Output channel DO No 1 value	Discrete Output channel DO No 2 value
0	None	Digital and Analogue commands will not move the actuator	NA	NA
1	Mono Discrete 1	DO 1 operates the actuator	0 – Stop 1 – Open 2 – Close	NA
2	Mono Discrete 2	DO 2 operates the actuator	NA	0 – Stop 1 – Open 2 – Close
3	Dual Discrete	DO1 and DO2 operate the actuator	0 – Stop 1 – Open 2 – Close	0 – Stop 1 – Open 2 – Close

CONTROL_SOURCE				
4	Local	Commands will not move the actuator	NA	NA
5	Local Auxiliary	Commands will not move the actuator	NA	NA
6	Mono Discrete 3	DO 1 operates the actuator	0 – Close 1 – Open 2 – Stop	NA
7	Transducer Test	Commands will not move the actuator	NA	NA

With the chosen mode (Mono Discrete 1, 2 or 3, or Dual Discrete) the actuator is controlled for fully open, fully closed or stop in mid travel using the DO channels, either DO1 or DO2, or both. Note that in addition the state of the DO3 and DO4 channels must be considered.

If Channel DO4 (ESD) is active then the actuator will go to its ESD (Emergency Shut Down) position and this will override controls from channels DO1 or DO2. Local controls will also be overridden. If Channel DO3 (ILOCK) is active and the interlock facility will be active and this may prevent valve movement in one, the other or both directions depending on the value written to the interlock output.

8.2 Setting Analogue Control

The Transducer block parameters for Motion Inhibit Timer, Deadband and Hysteresis must be set for the particular valve for the internal analogue positioner to function correctly. The AO block controls the actual output drive and is already instantiated to make it available. Settings for hysteresis and deadband ensure the actuator does not hunt around the setpoint whilst the motion inhibit timer is used to ensure the rated number of starts per hour is not exceeded.

Note: *If the fieldbus power is removed and restored the actuator will close to 0% as no signal will have been applied whilst the power was removed.*

FINAL_VALUE_HYSTERESIS
Set the motion hysteresis between 0-100% (typically 2%)
FINAL_VALUE_DEADBAND
Set the motion deadband between 0-100% (typically 2%)
INHIBITING_TIMER
Set the motion inhibit timer between 0-255 seconds (typically 20 sec)

8.3 Mixed Digital and Analogue Control

When using a mixed control strategy with both DO block control and AO block control it is necessary to make sure the Digital control (DO blocks) are set to 'Stop' before an Analogue control of the setpoint (DV) through the AO block will become effective. Digital controls (DO blocks) have a higher priority than Analogue control (AO block).

Where the actuator has been sent an AO value and subsequently a DO instruction is issued to Open, Close or Stop the valve any following AO value must differ from the initial value or no action will result.

- Step 1 Issue Desired position value of 'X'
- Step 2 Issue a Close digital command (or open or stop)

Step 3 Issue a Desired position value of 'Y'

X and Y must be different, if not the command issued at step 3 will have no result and the valve will remain in the position defined in stage 2.

8.2 Controlling Digital Inputs

The Digital Input blocks (DI1 and DI2) may be used to feed back information about the valve as specific data. The status fed back will depend on the trigger values set in the Transducer block parameters PRIMARY_VALUE_D1_SOURCE and PRIMARY_VALUE_D2_SOURCE.

The values set in these parameters are taken from the Valve Codes and any one of the codes 0 to 39 can be used for either DI block trigger source. The DI block input will then be true if the code is true.

Typically the value will be taken from one of the table below. Note that torque seating data is only available from the IQ and IQT. In the case of the AQ and Q the valve always stops at the position limit switch to prevent valve damage. There are other conditions which can be used to trigger the DI functions and the full list can be found using a configuration tool or from the list in the section on the Transducer block.

PRIMARY_VALUE_D1_SOURCE			
One of the conditions in the Valve codes is used to set the input for the DI 1 block. D1 will be true if the Valve code is true			
PRIMARY_VALUE_D2_SOURCE			
One of the conditions in the Valve codes is used to set the input for the DI 2 block. D2 will be true if the Valve code is true			
Valve Code No.	Identifier message	Description	Applicable Actuator Type
09	Opened at Position Lim	Valve Open Limit Switch reached	All
10	Closed at Position Lim	Valve Closed Limit Switch reached	All
11	Opened at Torque Lim	Valve Open and opening Torque Switch tripped	IQ/IQT
12	Closed at Torque Lim	Valve Closed and closing Torque Switch tripped	IQ/IQT
13	Opening	Travelling in Open Direction	All
14	Closing	Travelling in Close Direction	All
19	Aux Input 1	Auxiliary Input 1 Active	All
20	Aux Input 2	Auxiliary Input 2 Active	All
21	Aux Input 3	Auxiliary Input 3 Active	All
22	Aux Input 4	Auxiliary Input 4 Active	All

8.3 Controlling the IQ/IQT Actuator Relays (DO5 to DO8)

In the IQ/IQT actuator there are 4 relays R5-R8 that can be controlled by the Foundation network or by the actuator itself. The normal IQ/IQT process of controlling the relays by the settings for the 'S' values is suspended when a FF-01 module is fitted. The relays are then available for control either by a network input to DO5 to DO8 or by a Valve code for the actuator condition.

8.3.1 Relay Source

The initial choice in setting up the FF-01 is to set the Transducer block to select the source for each relay, either Fieldbus or Actuator. Fieldbus means controlling the relay by a DO signal whilst Actuator means controlling the relay by a Valve code.

RELAYS_SOURCE

Set the four relays individually to be operated either by a DO signal on the Foundation, or by an actuator event in the valve Code list.

8.3.2 Relay Trigger

If the choice for the control source is to use an Actuator event then the Transducer block setting for the actual event must be selected from the Valve code list. If the choice is to use a DO signal from the network then the default value for the trigger can be left in place.

RELAYS_TRIGGER

For each relay, if the RELAYS_SOURCE is set to Actuator, set the relay to be operated by a valve code as listed in the transducer block section. If set to Foundation leave at the default.

8.3.3 Relay View

The status of each relay can be seen by reading the Transducer block parameter RELAYS_VIEW. This parameter reports the relay condition as either 'set' or 'reset'.

8.4 Hard-wired Input Monitoring and Control

All the actuators can be controlled using direct contact inputs as well as the Foundation commands. Alternately the hard-wired inputs can be used as a method of feeding back data either directly from the Transducer block or through the two DI blocks. The selection for the function of these inputs is made in the Transducer block.

8.4.1 Aux Input Function

The initial decision is to choose whether to use the hard-wired Auxiliary inputs as controls or simply for monitoring. Selecting the mode in the AUX_FUNCTION parameter of the Transducer block determines the action for each of the inputs. Note that the function for the inputs when they are used for control is fixed.

AUX_FUNCTION		
Aux 1	Control function = Open command	Setting: 0 = Monitor, 1 = Control
Aux 2	Control function = Close command	Setting: 0 = Monitor, 1 = Control
Aux 3	Control function = Stop/maintain command	Setting: 0 = Monitor, 1 = Control
Aux 4	Control function = ESD command	Setting: 0 = Monitor, 1 = Control

When the inputs are chosen for control they will override the Foundation signals and remain the only method of control. The network will regain control only after all the settings are returned to 'monitor'. For IQ actuators a special version exists where the actuator may be controlled by both the network and the hard wired inputs at the same time. If this option is required please contact Rotork.

8.4.2 Aux Input Condition

At any time the state of the hard-wired inputs can be viewed in the Transducer block parameter AUX_VIEW. The data in this parameter shows if the input is active (closed circuit) or inactive (open circuit).

AUX_VIEW		
Aux 1	Control function = Open command	0 = inactive, 1 = active
Aux 2	Control function = Close command	0 = inactive, 1 = active
Aux 3	Control function = Stop/maintain command	0 = inactive, 1 = active
Aux 4	Control function = ESD command	0 = inactive, 1 = active

8.5 Viewing the Actuator Status

The current status of the actuator position and control availability is reported in several parameters of the transducer block. In some cases these parameters also reflect the state of the direct inputs as well as the Foundation controls.

8.5.1 Analogue Position and Torque Data

Before the actuator can accurately report the position of the valve the actuator must be moved between the fully open (100%) and fully closed positions whilst power is applied to the actuator and fieldbus. The Transducer block parameters relating to analogue position control (AO) and analogue feedback data (AI) are listed below.

FINAL_VALUE	Reports the setpoint (Desired Value) of the position controller associated with the AO block. The actuator will adopt this position unless it has been followed by a digital command or it is in Local control
PRIMARY_VALUE_POSITION	Reports the actuator analogue position as a % signal where 0% = fully closed and 100% = fully open. This is the input to AI channel 1.
PRIMARY_VALUE_TORQUE	Applicable to IQ actuators only, this is the value of torque currently generated by the actuator, or generated just before it stopped if the actuator is stationary. The scale is 0-120% for zero to rated torque

8.5.2 Digital Command and Status Readback data

The status of the digital commands can be viewed in the read back signals from the Transducer block. These parameters also include the condition of the hard-wired inputs when they are set for 'control'.

FINAL_POSITION_VALUE_D	Reports the current actuator Open/Stop/Close command status demanded. This will be the position adopted by the actuator unless it is in Local control or a subsequent analogue position has been sent over the network.
PRIMARY_VALUE_D1	Reports the status of the selected valve code for digital input (DI) channel 1. The signal will be true or false depending on the state of the valve code.
PRIMARY_VALUE_D2	Reports the status of the selected valve code for digital input (DI) channel 2. The signal will be true or false depending on the state of the valve code..
ESD_FINAL_POSITION_VALUE_D	Reports the current condition of the actuator Emergency Shut Down signal, inclusive of the hard-wired input..
ILOCK_FINAL_POSITION_VALUE_D	Reports the current condition of the actuator Interlock input signal, inclusive of the hard-wired input.

8.5.3 Actuator Condition Report

The 'Valve Status' parameter in the Transducer block reports the condition of the actuator by taking the highest listed Valve code that is true. If the actuator has a fault present (for example it is in Local control and cannot be controlled over the network) then this parameter will report the fact. If there are no faults on the actuator this parameter will report the next lowest condition in the Valve code list, from codes 0 to 2 (Stop, Open, Close).

VALVE_STATUS			
Reports one of the conditions from the Valve codes, the highest code is reported first.			
Valve Code No.	Identifier message	Description	Applicable Actuator Type
04	LOCAL OVERRIDE	Local/Stop/Remote selector in Local or Stop position	All
15	STOP and LOCAL OVERRIDE	Local/Stop/Remote selector in Local Stop position	All
16	Fail and Stopped at Position Mid and at Torque Lim	Valve Obstructed (actuator stopped in mid-travel and torque switch tripped)	IQ/IQT
33	FAIL and ESD	ESD Command Issued	All
34	FAIL and control not available	Monitor Relay (Local, Local Stop, or Thermostat tripped) active	NA
35	FAIL and Battery Low	Low Battery	IQ/IQT
36	FAIL and Stalled	Valve Jammed	IQ/IQT
37	FAIL and Handwheel moving	Manual Movement Detected	All
38	FAIL and Hot	Thermostat Trip	All
39	FAIL and Maintain	Not implemented as trigger event	NA

In addition the position of the valve can be determined from the 'Stopping At' parameter in the Transducer block. This parameter again reports data from the Valve codes, but the information is limited to the valve position and does not include any alarm or failure conditions for the control system. Where more than one code may be satisfied by the actuator condition the actual one reported will be the highest code.

STOPPING_AT			
Reports one of the position of actuator from the Valve codes, the highest code is reported first..			
Valve Code No.	Identifier message	Description	Applicable Actuator Type
00	STOP	Stationary in Mid Travel or Local/Stop/Remote selector in Stop position	All
01	OPEN	Open and Open Limit switch or Open Torque switch true, or actuator moving in open direction	All
02	CLOSE	Closed and Close Limit switch or Closed Torque switch true, or actuator moving in closed direction	All
03	Motion Inhibited	Motion Inhibit Timer Running	All
05	Position Achieved	(assigned to actuator stationary at desired position)	All
06	Torque Limit Achieved	(assigned to at desired position and stopped on torque)	IQ/IQT
07	Moving	Actuator in motion either opening or closing	All
08	Stopped at Position Mid	(assigned to stopped in mid-travel at desired position)	NA
09	Opened at Position Lim	Valve Open Limit Switch reached	All
10	Closed at Position Lim	Valve Closed Limit Switch reached	All
11	Opened at Torque Lim	Valve Open and opening Torque Switch tripped	IQ/IQT
12	Closed at Torque Lim	Valve Closed and closing Torque Switch tripped	IQ/IQT
13	Opening	Travelling in Open Direction	All
14	Closing	Travelling in Close Direction	All

9 UPDATING THE FF-01 FIRMWARE

Both sections of the FF-01 module have related firmware embedded in them. The roundcard firmware can be updated by downloading new firmware from a PC to the roundcard using the SMAR FDI 302 programming tool. The interface firmware is updated by removing the COP8 microcontroller and replacing it with a microcontroller that has been pre-programmed with the required version of firmware.

Both the round card firmware and microcontroller upgrade must be supplied by Rotork.

In order to carry out an upgrade the following tools will be required -

- Computer with Windows 95, 98 or NT operating system, Pentium P120 processor, 32 Mbyte RAM and serial port
- Anti-static mat and wristband.
- Smar FBTools download software.
- SMAR FDI 302:- Program Download Tool
- Foundation Fieldbus power supply: (18V min to 24V max)
- Fieldbus Power supply cable with suitable connector.
- Microcontroller upgrade part: COP8 programmed with Rotork firmware.
- Smar roundcard firmware upgrade disk with new (.abs) file.

9.1 Remove the FF-01 from the Actuator

In order to carry out the upgrade it is recommended to remove the module from the actuator and take it to a clean workshop environment.

To gain access to the FF-01 module the actuator electrical cover should be removed to gain access to the card. The connecting looms and screening can lid should be removed making a note of their positions for subsequent re-assembly. The module should be removed from the actuator, taking care to follow all necessary anti-static precautions. Once removed the module should be placed in an anti-static bag for transfer to a workshop area where it can be reprogrammed.

9.2 Connect the FF-01 to the PC and Power Supply

During programming, the FF-01 module should be placed on an anti-static mat, in a clean workshop area. The module must be connected to a Foundation Fieldbus power supply and to the PC running the SMAR FBTools application.

A Foundation Fieldbus power supply must be used since the SMAR round card is powered from this bus. Note that the 24V DC supply must include the correct filtering components to be suitable for this task.

Attach the FDI 302 programming tool to the Fbboard round card using the attachment clip supplied. The FDI 302 will only fit in the orientation shown. If the programming tool does not appear to fit, rotate it through 180° and try again. Do not force the tool to fit the attachment holes as this could damage both the tool and the Fbboard.

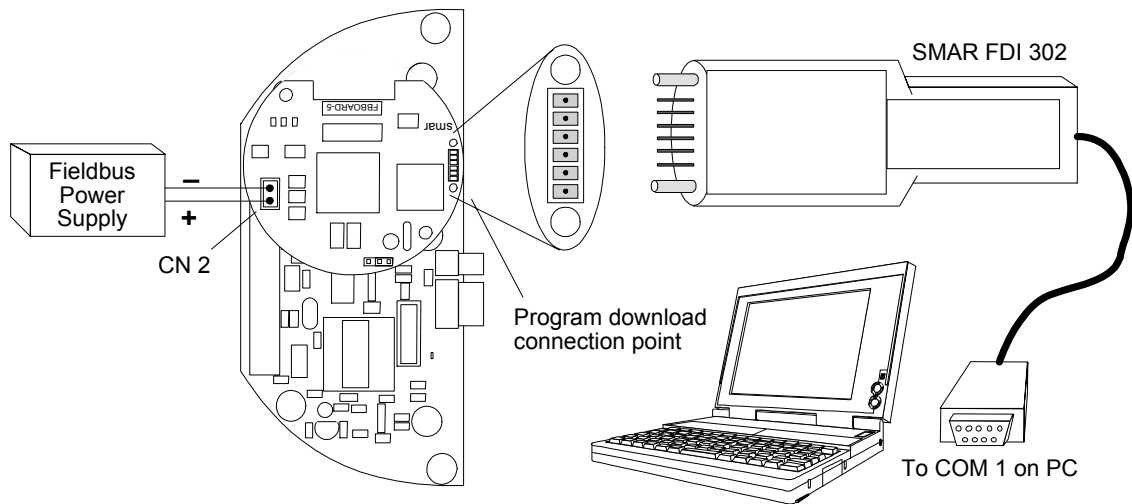
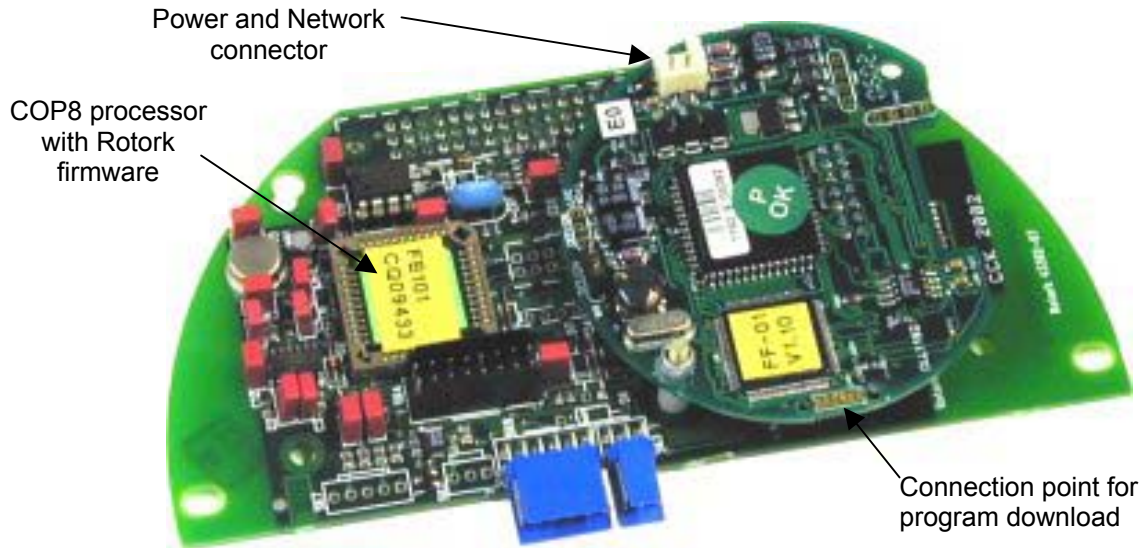

Fig 18 FF-01 module programming connections

The 9 pin D type connector for the FDI 302 should be connected to the serial port of the PC. This can be either the COM1 or COM2 but normally COM1 is used. Make a note of the port being used.

Connect the round card to the fieldbus power supply using the fieldbus power supply cable. This power supply should have a filtered output and should have an output of between 18V min and 24V max. To enable reprogramming the Fbboard must be powered by the fieldbus.

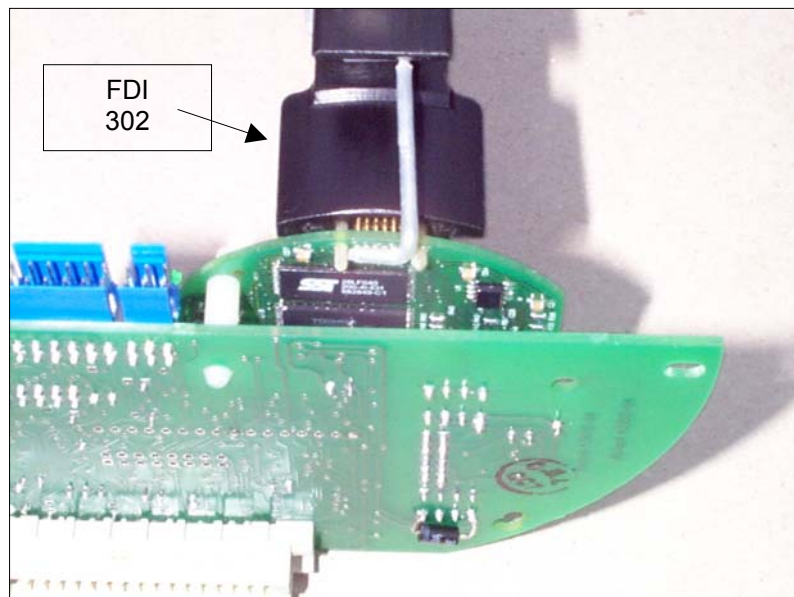

Fig 19: Connecting the FDI 302 to the round card (shown with screening can removed).

9.3 Downloading the SMAR Firmware

The PC should be one that has had the SMAR FBTools software installed. Run the FBTools software, the installation will have added an icon, which can be selected from the windows start list. Select the FB302 as the device and click the finish button.

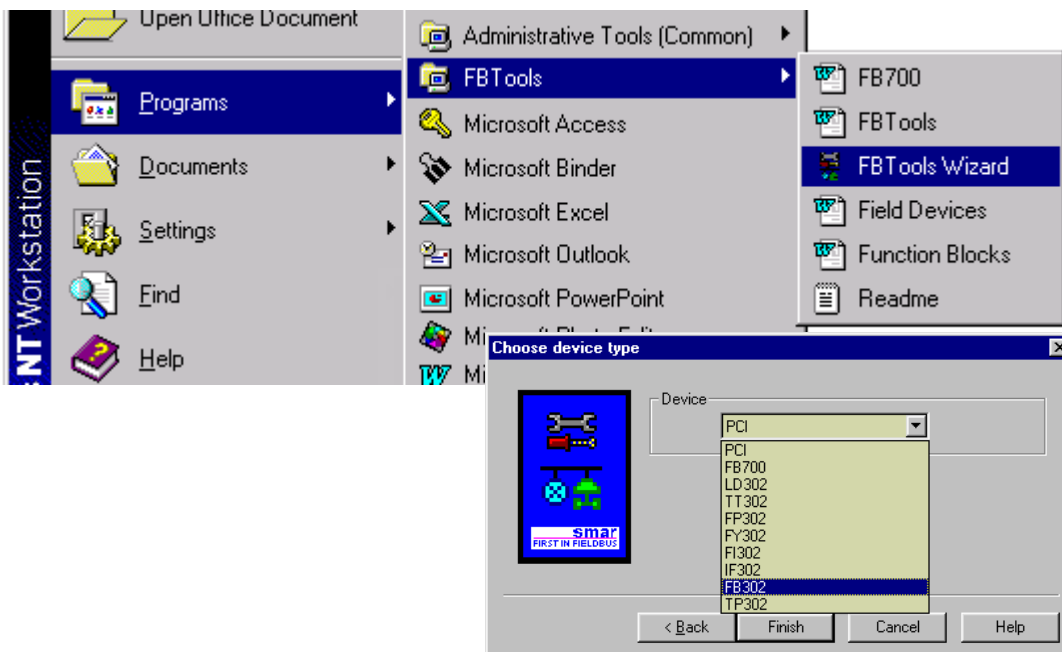

Fig 20: Select the download tool type to FB302

Next the serial download window will appear. First the port should be set to match the serial port to which the FDI 302 is connected

The firmware file to be downloaded is supplied on a floppy disk. Place this disk in the floppy disk drive and select this as the file to download.

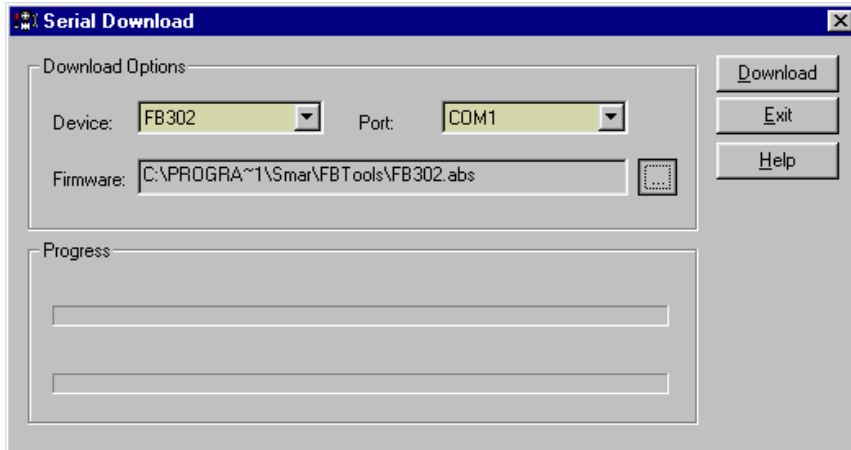

Fig 21: Serial Download Window

To select the file to download click the button next to the firmware text label, this is the button indicated by . Navigate to the floppy drive and reveal the list of files available for downloading to the Fbboard.

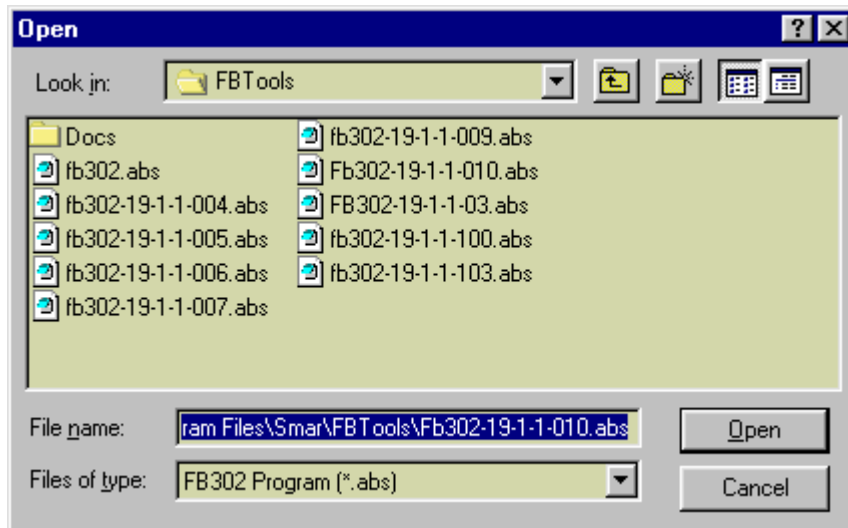

Fig 22: Select the file to download

Be sure to have selected the file on the floppy disk drive containing the new firmware.

Select and open the latest file on the firmware upgrade disk, this will cause the display to return to the previous window. Once the correct file and comm port have been selected then proceed to download the file to the roundcard by clicking on the download button.

If the Fbboard is both powered and the FDI 302 is correctly connected the selected firmware will be downloaded to the Fbboard.

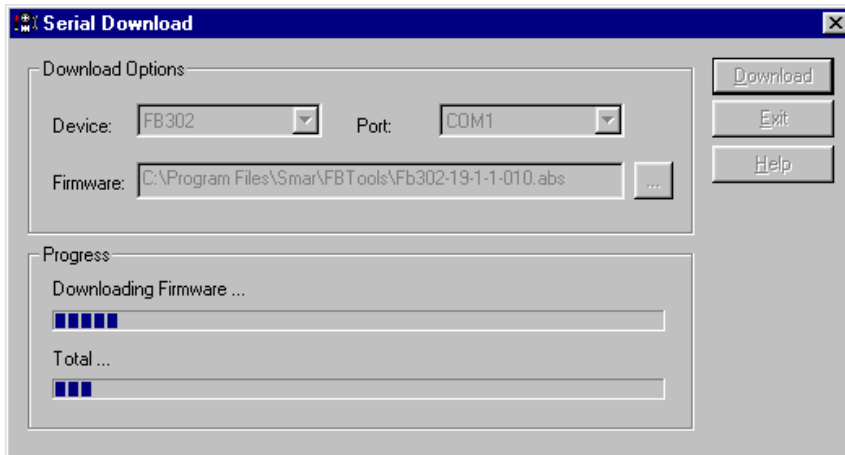

Fig 23: File downloading screen

Allow the download to complete. Remove the fieldbus power connection then remove the download tool.

9.4 Updating the COP8 Firmware

To change the Rotork interface firmware remove the COP8 micro controller from its socket, using a PLCC chip extraction tool, and replace it with the pre-programmed COP8 micro controller which has been supplied as an upgrade.

The chip must be correctly orientated when placing it into the socket. This is achieved by lining up the pin 1 indication marks and the locating chamfer on both the chip and the socket.

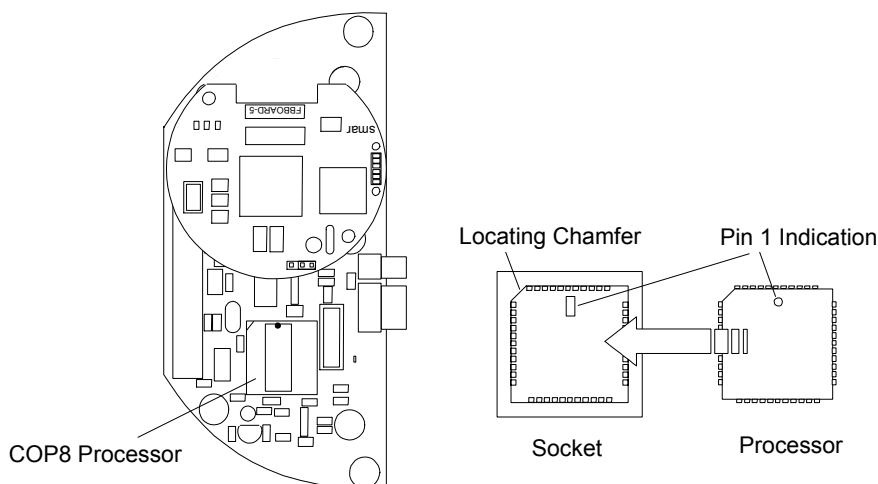

Fig 24: Replacing the COP8 Processor

9.5 Re-assemble the Actuator

Maintaining anti-static precautions the fieldbus card should be placed back in the actuator. The card should be reconnected to the multipin connector and all looms to the FF-01 module should be reconnected. Make sure that all looms are connected to the correct place before replacing the electrical cover.

The actuator is now ready to use the upgraded firmware.

10 DEVICE DESCRIPTION FILES

The Rotork FF-01 Foundation Fieldbus module requires certain device description files to be loaded onto the host or configuration computer to allow the system to be set up. These files are not required for the operation of the network. Configuration can only be achieved if the DD files are available to the configuring software.

The Device Description files provide the Configuration tool with the information it needs to identify the Function Blocks in the device and the text labels associated with each parameter.

When the FF-01 is connected to a host system such as a Fisher DeltaV or a Yokogawa Centum there may be a need for an additional file used by the host system to allow it to recognise the Rotork device. These files are maintained and supplied by the host system suppliers. Should a copy of any of these files be needed they should be obtained from the host system manufacturer.

10.1 ITK3 DD Files

File	File Name	ITK Version
Firmware File	FB302-19-1-1-107.ABS	3.0
Capabilities File	010101.CFF	3.0
Device Resource File	0101.DRF	3.0
Symbol File	0101.SYM	3.0
Device Description	0101.FFO	3.0
Rotork Firmware	44596-01	3.0

For systems meeting the interoperability tests level ITK3 a .drf file is required. For later ITK versions only the .sym, .cff and .ffo files are required.

10.2 ITK4 DD Files

File	File Name	ITK Version
Firmware File	FB302-19-1-1-110.ABS	4.01
Capabilities File	020101.CFF	4.01
Symbol File	0201.SYM	4.01
Device Description	0201.FFO	4.01
Rotork Firmware	44596-02	4.01

Whenever a system configuration is being made the DD files must be available in a folder on the machine performing the configuration. Rotork supplies current versions of these files with the hardware or from the Rotork web site.



<http://www.rotork.com>

Rotork reserves the right to amend and change specifications without prior notice

Published data may be subject to change.

UK Head Office

Rotork Controls Ltd
Bath
England
BA1 3JQ

Tel: +44 (0) 1225 733 200
Fax: +44 (0) 1225 333 467
e-mail: mail@rotork.co.uk

USA Head Office

Rotork Controls Inc
675 Mike Crossing Blvd
Rochester
New York 14624
USA

Tel: +1 716 328 1550
Fax: +1 716 328 5848
e-mail: info@rotork.com