

rotork®

Keeping the World Flowing
for Future Generations

Foundation Fieldbus® Actuator control



Serial communication and control of Rotork actuators

Reliability in critical flow control applications

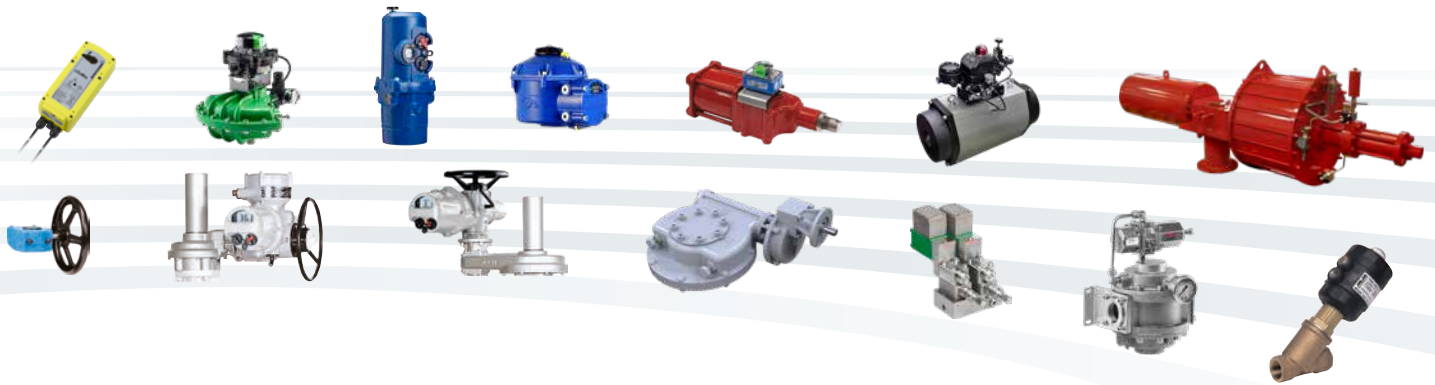

› Reliable operation when it matters

Assured reliability for critical applications and environments. Whether used infrequently or continuously, Rotork products will operate reliably and efficiently.

› Quality-driven global manufacturing

We offer products that have been designed with over 60 years of industry and application knowledge.

Our research and development ensures cutting edge products are available for multiple applications across multiple industries.

› Customer focused service and worldwide support

Rotork solve customer challenges and develop new solutions that are tailored to the needs of our clients.

We offer dedicated, expert service and support from initial inquiry, to product installation, to long-term after sales care.

› Low cost of ownership

Long-term reliability prolongs service life.

Rotork helps to reduce long-term cost of ownership and provides greater efficiency to process and plant.

Foundation Fieldbus

Section	Page	Section	Page
Introduction	4	Foundation Fieldbus features	8
Foundation Fieldbus overview	4	Control and feedback	8
Foundation Fieldbus module	5	Valve torque profile data	10
Foundation Fieldbus network	5	Methods	10
Foundation Fieldbus function blocks	6	Partial Stroke	10
Function block connections	6	Certification	10
Link Master capability	6	Device Description files	10
		Foundation Fieldbus technical data	11
		Site services	12



Comprehensive product range serving multiple industries

Rotork products offer improved efficiency, assured safety and environmental protection across sectors such as the Power, Oil & Gas, Water & Wastewater, HVAC, Marine, Mining, Pulp & Paper, Food & Beverage, Pharmaceutical and Chemical sectors.

Market leaders and technical innovators

We have been the recognised market leader in flow control for over 60 years.

Our customers rely upon Rotork for innovative solutions to safely manage the flow of liquids, gases and powders.

Global presence, local service

We are a global company with local support.

Manufacturing sites, service centres and sales offices throughout the world provide unrivalled customer services, fast delivery and ongoing, accessible support.

Environmental Social and Governance is at the heart of our business

We have a range of policies in place that support our performance across environmental, social and governance topics. The majority of our policies are publicly available.

Introduction

Foundation Fieldbus® is one of the most widely used field networks in process control and batch control systems.

Rotork actuators fitted with Foundation Fieldbus network interface cards connect seamlessly onto the standard Foundation H1 bus system. They provide a wealth of control capabilities including command structures suitable for isolating and positioner duties.

The ability to report extensive actuator feedback data as well as network system diagnostic information makes Rotork the first choice for use with a Foundation Fieldbus system.

The latest Rotork Foundation Fieldbus card is fully compliant with IEC61158-2 for use on H1, 31.25 kbit/s networks using 2-wire communication. The use of this technology and well proven interface stack allows maximum flexibility in the way the embedded function blocks perform.

Despite the complexities of the system, Rotork has addressed the concerns of users and designed this option card to be simple and easy to use.



Foundation Fieldbus overview

- Fully compliant with International open fieldbus standard IEC61158-2
- Uses IEC61158-2, 2-wire communication
- Connects with H1 communication bus
- Communication speed 31.25 kbit/s
- Network can use trunk and spur topology, ideal for replacing existing devices
- Maximum of 32 devices per segment without repeaters
- Includes Link Master and LAS capability
- Contains fully configured AI, AO, DI, DO, PID, CS blocks
- Independent HIST approval by major DCS vendors
- Foundation ITK certified for inter-operability
- Device description files with 'Methods' for simple set up

For more information on Foundation Fieldbus consult the web site at <http://www.fieldbus.org/>

Foundation Fieldbus is supported by leading DCS vendors such as Emerson, Yokogawa and Honeywell.



Foundation Fieldbus module

The Foundation Fieldbus module is fitted inside the actuator electrical housing and interfaces directly with the actuator electronics. Once fitted, the normal commands associated with moving the actuator together with feedback and historical data become available on the Foundation 2-wire H1 highway. Controls include discrete DO functions for isolating valve duty and a position controller in the AO block.

Feedback information includes signals that are not normally available with conventional wiring. For example, the valve torque profile, giving torque data across the valve stroke is reported over the network.

The network interface is powered from the bus, drawing an average of 20 mA once running. The network is optically isolated from the actuator controls and electronics module.



Foundation Fieldbus network

The Foundation Fieldbus network uses voltage based signals and all the actuators and field transmitters are wired in parallel across the 2 wires.

There are several acceptable preferred topologies for the cabling. Either a Tree, where the trunk line terminates in a junction box and the devices are all connected to the box, or a Spur, where the devices are linked to the trunk line with taps, or a combination of both techniques.

In general, although a daisy chain is acceptable, it is often not preferred as it makes the removal of a device for maintenance more difficult. Ideally, disconnect switches are included on daisy chain systems to allow simple device removal. In all cases the highway must be terminated in two places using approved termination devices. These should be located at either end of the main trunk line.

A power supply and conditioner is also required and this is normally located in the DCS gateway. The power supply is used to energise the network interface in the Rotork Fieldbus module. The total highway length is limited to 1900 metres, including all the spurs.

Total length = Trunk length + sum of all Spur lengths

The spurs should be kept to a minimum and the ideal length is less than 30 metres, though the maximum permitted length for a spur is 120 metres. As the number of devices increases, so the maximum length of each spur is reduced.

The installation guides available from Fieldbus Foundation provide more information on designing the system. Most segments are limited to around 12 to 16 devices to keep the volt drop on the cable within acceptable limits and also ensure sufficient resources are available in the DCS to support the number of devices being used.

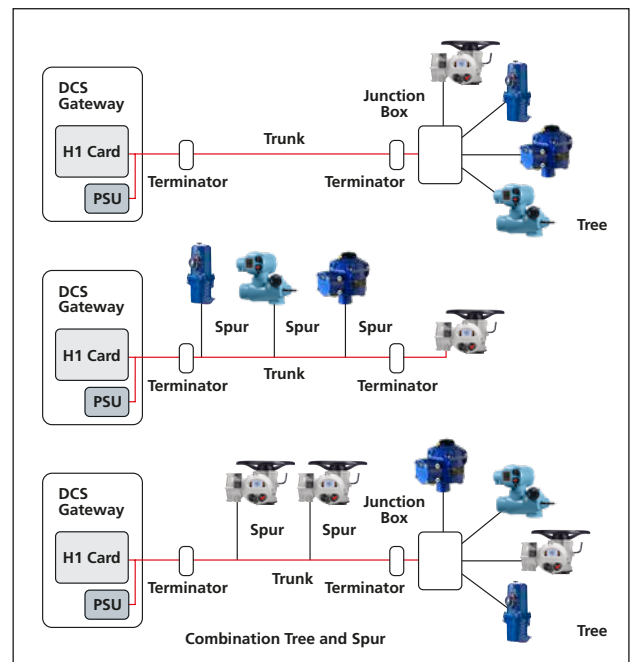

Maximum total length including spurs (metres)	Spur length (each spur)			
	1-12 spurs	13-14 spurs	15-18 spurs	19-24 spurs
1900	120	90	60	30

Foundation Fieldbus function blocks

With Foundation Fieldbus the plant control strategy is based on the use of function blocks. These building blocks are used to design the control system for the process and each device on the network contributes blocks to allow for data to be retrieved or outputs to be operated.

The Rotork actuator is a complex device with both inputs and outputs. The motor starter and position controller are integrated within the actuator, removing the need to construct actuator control functions in the host system.

The Rotork Fieldbus module includes a comprehensive set of function blocks to allow the actuator to be controlled and report its status over the network. These function blocks maximise the capabilities of the Foundation Fieldbus system by packing multiple digital data bits into each DI block and ensuring that the reported data from the BKCAL OUT signals is also filled with the maximum amount of useful data.

In addition, the information relayed within the Transducer block permits extensive examination of the actuator and the valve signature for diagnostic and maintenance purposes.

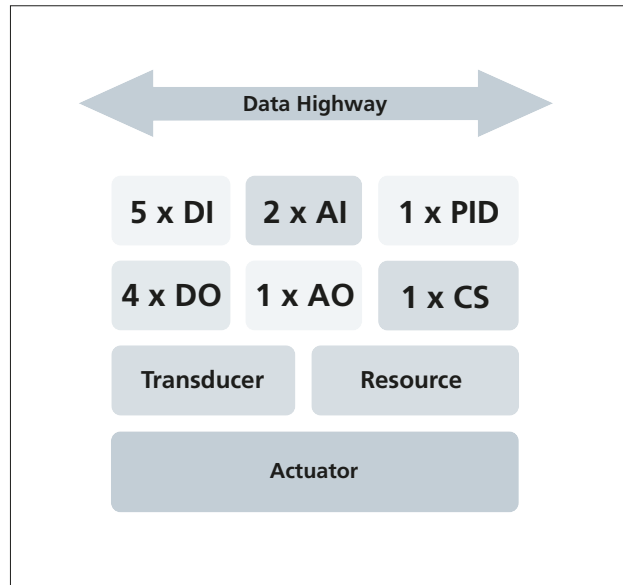

Function block connections

Typically block diagrams are used to construct the controls and reporting required by the process. The Rotork module meets one of the Foundation Fieldbus primary objectives by allowing 'control in the field'.

The PID block incorporated in the actuator allows the distribution of the control function. Also, with the PID block in the actuator together with the AO block the number of VCRs required is reduced, as this connection is inside a module and does not need to be added to the communication schedule.

Link Master capability

The ability of the Rotork module to act as the Link Active Scheduler allows control to continue in the event of the primary LAS failing. The Link Active Scheduler is responsible for controlling the highway communications and will normally reside in the host system. In applications where a single loop controller is being constructed there is no need for a host and the actuator can control all the communications.

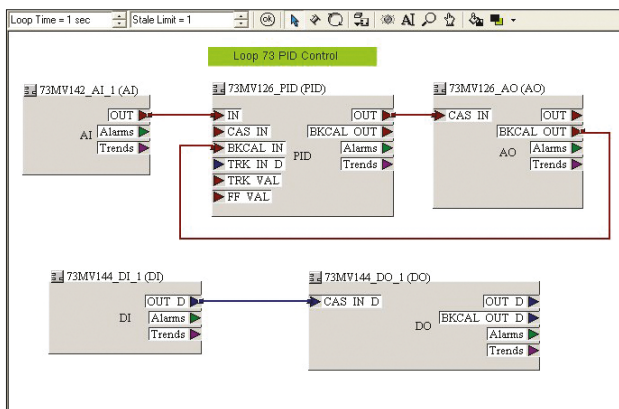

PID Control

Foundation Fieldbus function blocks

The Rotork Fieldbus module contains 16 function blocks for the control and monitoring of the actuator and to report the actuator status to other devices on the network or the host system. The blocks include AI, AO, DI, DO, PID functions and a Control Selector Block (CS) and all conform to the Foundation standard for each type of block.

All the function blocks can be individually tagged as required. Blocks may be set for use in Automatic, Manual or other special modes for control during the execution of the function block strategy for controlling the plant and the associated actuators. Blocks not being used are normally set to OOS or Out Of Service.

The Transducer block is especially important. It is used to set up the functions of the actuator and also to provide the valve signature data. Many of the functions within the Transducer block are specific to actuator control and have been developed by Rotork to match the requirements for valve actuators.

Function blocks provide the basis for interoperability between devices. Blocks in one device link seamlessly to blocks in other devices on the same segment or system.

Function blocks and execution times		
Block type	Quantity	Execution time
Analogue Input (AI)	2	50 ms
Analogue Output (AO)	1	50 ms
Discrete Input (DI)	5	50 ms
Discrete Output (DO)	4	50 ms
Controller (PID)	1	100 ms
Control Selector (CS)	1	50 ms
Transducer (Tb)	1	N.A.
Resource (Rb)	1	N.A.

The logical connections and data exchange between the blocks are handled by the network communication protocol.

Within the actuator the Transducer block provides the connection between the actuator's function blocks and the controls and measurements of the actuator itself. Two analogue input channels, one analogue output channel, five discrete input channels and four discrete output channels link the control function to the actuator.

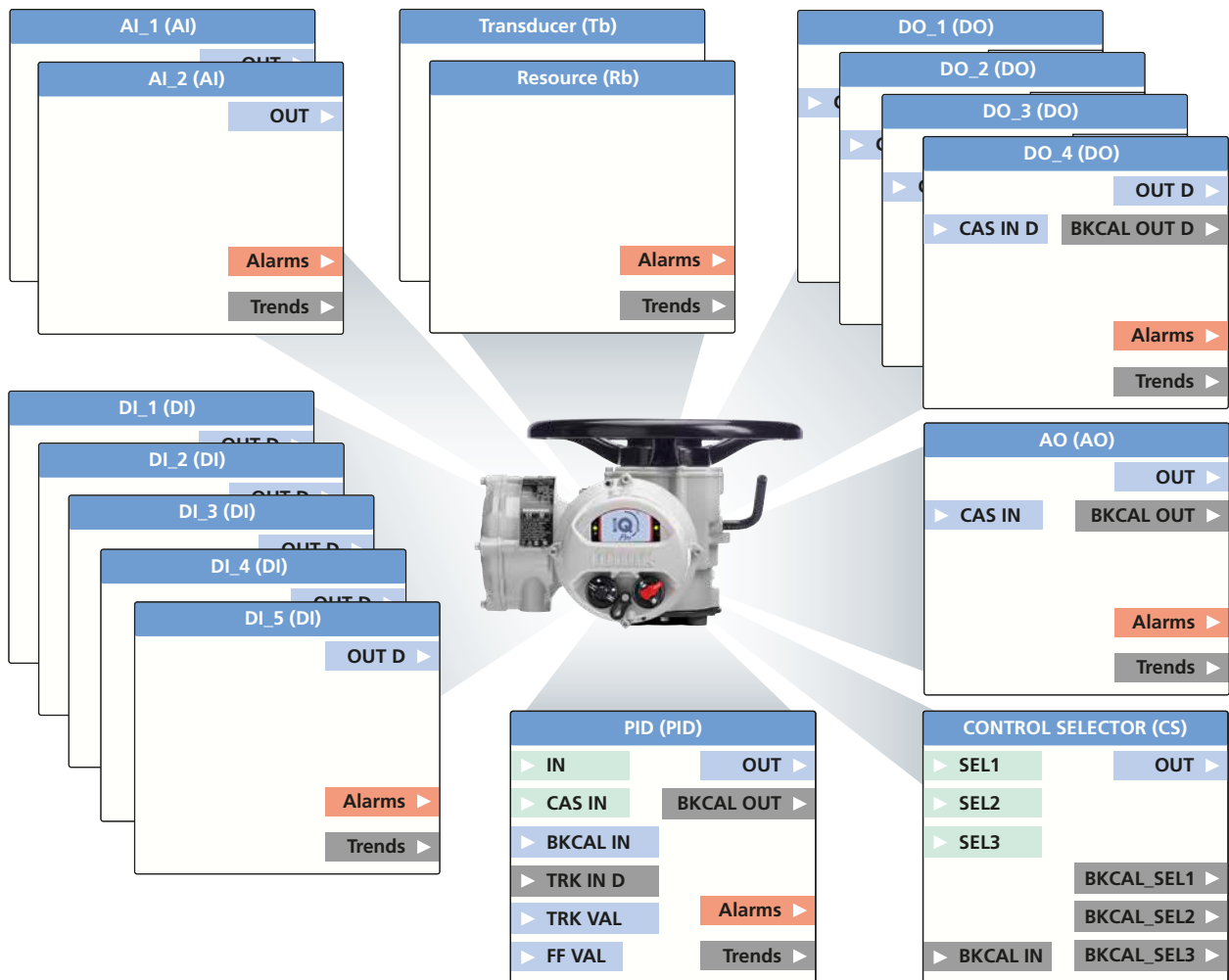

Foundation Fieldbus features

Control and feedback

The analogue feedback and control blocks (AI and AO) are used for the valve position controller, which is independent of the PID block. Position resolution is to 0.1%, though care must be taken to ensure the actuator and valve can achieve this level of accuracy.

The multi-state discrete inputs and outputs use the 8 bits within each DI or DO function to maximise the amount of digital data transferred in the blocks. In the case of the DO blocks, control provision is included for host systems that are unable to encode multiple bits into a single output.

These blocks each have a different primary output in the first bit. Similarly the DI blocks each include 8 digital input signals and the host can decode the individual signals. If the host is unable to decode the information, each DI block carries the most important information in its first bit.

Any device on the system can use the PID block since it is not tied to a transducer block channel.

Control Data	IQ/IQT**	Q	CVA	CMA	ROMpak	SKIL/EH
Digital Outputs DO(1) - DO(4):						
Stop	✓	✓	✓	✓	✓	✓
Close	✓	✓	✓	✓	✓	✓
Open	✓	✓	✓	✓	✓	✓
ESD	✓	✓	✓	✓	✓	✓
Positioner Enable	✓	✓	✓	✓	✓	✓
Partial Stroke	✓	✓	X	X	X	✓
Relay 1	✓*	X	X	✓	X	X
Relay 2	✓*	X	X	✓	X	X
Relay 3	✓*	X	X	X	X	X
Relay 4	✓*	X	X	X	X	X
Analogue Outputs AO:						
Desired position	✓	✓	✓	✓	✓	✓

* Extra relay board must be fitted. ** This applies to IQ3/IQT3 and IQ3 Pro/IQT3 Pro.

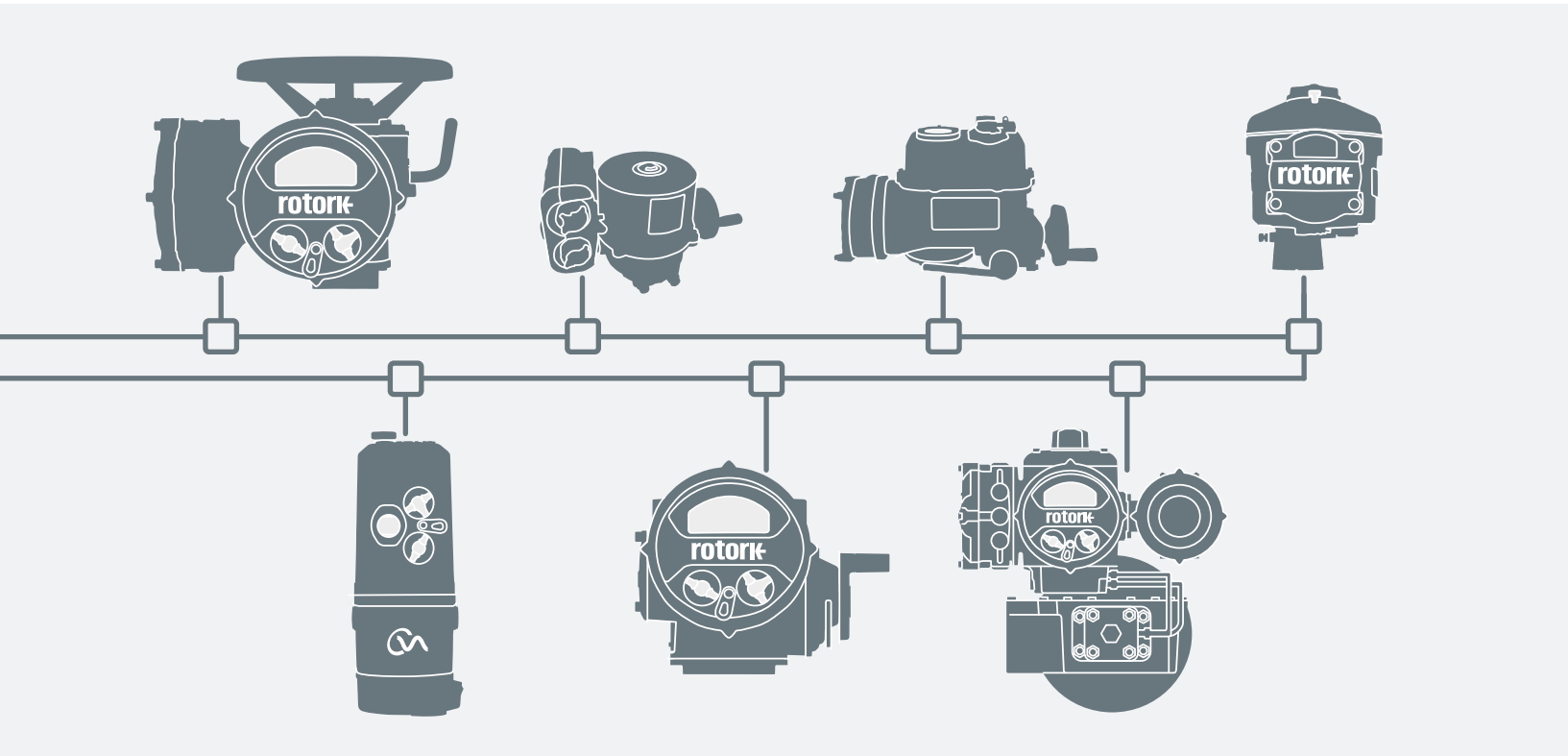

Foundation Fieldbus features

	Feedback Data	IQ/IQT**	Q	CVA	CMA	ROMpak	SKIL/EH
Digital Inputs:							
DI(1)	Close limit switch	✓	✓	✓	✓	✓	✓
	Open limit switch	✓	✓	✓	✓	✓	✓
	Actuator moving	✓	✓	✓	✓	✓	✓
	Actuator running closed	✓	✓	✓	✓	✓	✓
	Actuator running open	✓	✓	✓	✓	✓	✓
	Remote control selected	✓	✓	✓	✓	✓	✓
	Local stop selected	✓	✓	✓	✓	✓	✓
	Local control selected	✓	✓	*1	✓	✓	✓
DI(2)	Close limit switch	✓	✓	✓	✓	✓	✓
	Open limit switch	✓	✓	✓	✓	✓	✓
	Actuator running open	✓	✓	✓	✓	✓	✓
	Actuator running closed	✓	✓	✓	✓	✓	✓
	Not in remote control	✓	✓	✓	✓	✓	✓
	General alarm	✓	✓	✓	✓	✓	✓
	Valve obstructed	✓	✓	✓	✓	✓	✓
	Valve jammed	✓	✓	✓	✓	✓	✓
DI(3)	Remote control selected	✓	✓	✓	✓	✓	✓
	Local stop selected	✓	✓	✓	✓	✓	✓
	Local control selected	✓	✓	*1	✓	✓	✓
	MIT/Interrupter active	✓	✓	X	X	✓	✓
	Open interlock active	✓	X	X	X	X	X
	Close interlock active	✓	X	X	X	X	*3
	Positioner moving actuator	✓	✓	✓	✓	✓	✓
	Slow mode	*4	X	X	X	X	X
DI(4)	General alarm	✓	✓	✓	✓	✓	✓
	Thermostat tripped	✓	✓	✓	✓	✓	*2
	Monitor relay	✓	✓	✓	✓	✓	✓
	Valve Obstructed / Jammed	✓	✓	✓	✓	✓	✓
	Partial stroke error	✓	✓	X	X	X	✓
	Manual movement	✓	✓	X	X	X	✓
	Battery low	✓	X	X	X	X	X
	Watchdog recovery	✓	✓	✓	✓	✓	✓
DI(5)	Actuator moving	✓	✓	✓	✓	✓	✓
	Aux input 1	✓	X	X	X	X	✓
	Aux input 2	✓	X	X	X	X	✓
	Aux input 3	✓	X	X	X	X	✓
	Aux input 4	✓	X	X	X	X	✓
	Open interlock active	✓	X	X	X	X	X
	Close interlock active	✓	X	X	X	X	*3
	Partial stroking	✓	✓	X	X	X	✓
Analogue Inputs:							
	Measured actuator position	✓	✓	✓	✓	✓	✓
	Current actuator torque	✓	X	X	✓	X	X

- 1 Test mode
- 2 Fault Relay
- 3 HW Partial Stroke input
- 4 IQT only

Note: The Aux input 1-4 and Relay 1-4 outputs may be used for direct actuator remote control and indication.

** This applies to IQ3/IQT3 and IQ3 Pro/IQT3 Pro.

Foundation Fieldbus features

Valve torque profile data

The valve signature is recorded by plotting the valve position feedback against the torque feedback on IQ range (IQ3/IQ3 Pro/IQT3/IQT3 Pro) and CVA range electric actuators, (note that the travel time is constant and set by the motor speed and gearing).

Alternatively, the module's Transducer block contains 22 parameters giving the value of the torque generated at 10% intervals across the valve stroke. These values are for the torque generated in both the opening and closing directions. The values in these parameters are updated each time the actuator moves. Using these internally recorded values increases the accuracy of the profile as there are no transmission delays in collecting the data.

Two more parameters contain values for the number of occasions the actuator has been started in both the open and close direction. These parameters allow the actuator usage to be examined.

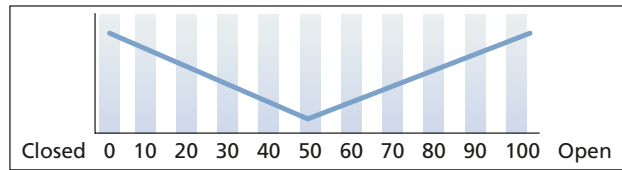

Opening Direction Torque

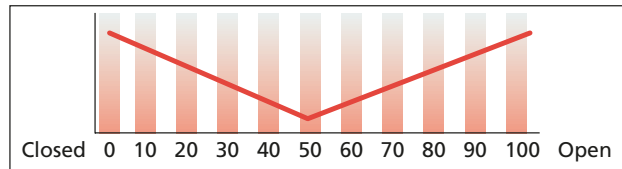

Closing Direction Torque

Starts - Open	7796
Starts - Close	7421

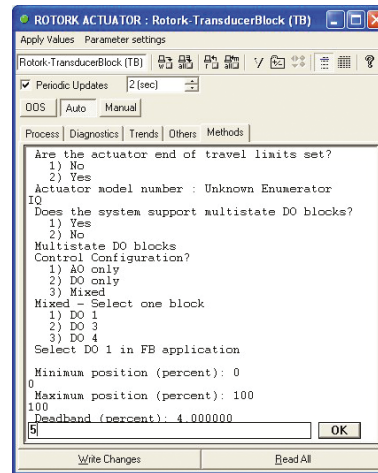

Methods

The Transducer block includes inbuilt 'Methods'. This feature is invaluable in leading the commissioning engineer through the process of setting up the primary requirements for the control of the actuator. This feature makes the Rotork Fieldbus module extremely straightforward to set up.

Engineers are also led through the stages needed to define the way the actuator is to be operated on the Foundation segment. The selection of yes or no for multi-state support ensures the correct setting for the DO and DI blocks that are used by the host system.

Partial Stroke

The Partial Stroke command enables the Rotork Fieldbus module to be used on valves with critical control requirements. The successful partial stroking of these valves is used as an indication that the valve is available for operation. The Foundation Fieldbus card has a specific Discrete Output command to initiate a partial stroke and cause the valve to move by a small predetermined amount from one or other end position. If the valve fails to complete the action in a specified time an alarm bit is set in Discrete Input DI-4.

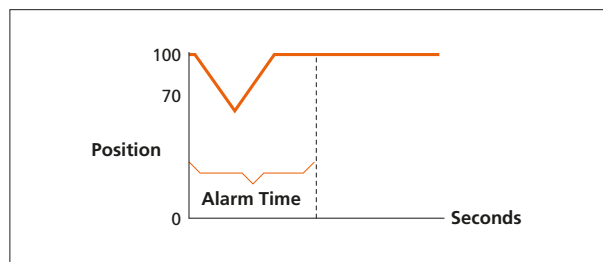

Certification

Independent testing and certification by the Fieldbus Foundation ensures complete interoperability with any other ITK tested Foundation products.

This certification together with extensive HIST (Host Interoperability System Test) work carried out with DCS manufacturers provides peace of mind for system integrators.

Device Description files

The DD files, including the cff file, have all been independently examined and verified by the Fieldbus Foundation. These files are the key to operating the Rotork Fieldbus module on the Foundation system as they uniquely describe the card in the actuator.

Once the card is identified by the DCS, it is configured for operation according to the control requirements for the actuator. The configuration data is retained on the card, even when the power is removed, to ensure continuity in the control of the plant.

Foundation Fieldbus technical data

Device:	Rotork Foundation Fieldbus actuator module
Network interface:	IEC 61158-2 electrical standard for 2 wire connection
Data rate:	31.25 kbit/s
Network compatibility:	Foundation H1 network
Physical layer:	Standard-power signalling, bus- powered, non I.S.
Current consumption:	20 mA operating current (inrush current 20 mA - no extra current)
Interface operating voltage:	9 to 32 VDC Input is not polarity sensitive
Communication stack:	Fieldbus Inc
H1 device class:	Link Master
Interoperability test:	ITK 5.1 (ITK6 available on request)
Number of VCRs:	20
Function blocks:	2 x AI - Analogue Input 1 x AO - Analogue Output 5 x DI - Discrete Input (up to 8 feedback signals per DI) 4 x DO - Discrete Output (up to 8 outputs per DO) 1 x PID - Controller 1 x Tb - Transducer block 1 x Rb - Resource block 1 x CS - Control Selector
Data files:	Up-to-date Device Description, Capability and Symbol files are available to download from www.rotork.com
Enclosure:	Suitable for fitting within Rotork IQ, IQT, Q, SI/EH, ROMpak and CMA range actuators
Environment:	-40 to +70 °C, environmentally protected by Rotork actuator double-sealing to IP68 (IQ, IQT, SI/EH, Q and CVA ranges)

Rotork Foundation Fieldbus supporting documentation and software are available for download at www.rotork.com

PUB089-005

Foundation Fieldbus installation manual



Site services

Rotork understands the value of prompt, punctual and superior site services. Rotork Site Services have specialist expertise, insight and experience in service support for mission-critical flow control and instrumentation solutions for oil and gas, water and wastewater, power, chemical process and industrial applications. We offer global frontline support backed by dedicated in-house experts.

Our service solutions increase plant efficiency and reduce maintenance costs, while workshop services return equipment to as-new condition. Our experience and understanding of the flow control industry means we have extensive insight and ideas of what we can do to provide significant value to our customers and their operations.

Rotork Site Services is comprised of two main areas; Lifetime Management and Site Services. Lifetime Management is the suite of services within Rotork Site Services which help you manage the risk associated with aging assets and includes our Reliability Services offering. Site Services comprises essential actuator service, repair, maintenance and upgrades.

Rotork has specialist expertise, insight and experience in flow control.

We provide insight into how we can deliver value to our customers.

Our service solutions increase plant efficiency and reduce maintenance costs.



Site services

Lifetime Management

The services available within Lifetime Management offer a complete solution to managing the risks associated with the life cycle of your equipment and their obsolescence (which compromise reliable performance and valuable uptime).

The aim of Lifetime Management is to provide you with constant support and minimum- to- no disruption to your production flow. It is a customisable service, offering designed to seamlessly maintain and improve your assets. We manage the inherent risks associated with advances in technology, component obsolescence and ageing equipment for you. We are committed to helping customers maximise the continuous, fault-free operation and working life of their actuators. Supporting the continuous and reliable operation of your plant allows for improved performance and increases in valuable uptime.

Lifetime Management covers:

- Reliability services
 - Basic - health check
 - Standard - planned maintenance
 - Premium - enhanced maintenance
- Upgrade services (Retrofit)
- Planned shutdown support
- Life cycle services
- Overhauls/refurbishment
- Customised spares programme
- Intelligent Asset Management (iAM) reporting



Site Services

Rotork Site Services (RSS) provides the essential on-site actuator service, repair, maintenance and upgrades part of our service offering, plus the commissioning of new actuators and applications. It includes off-site work completed at a Rotork Support Centre including recertification, automation, testing and product selection.

Our decades of experience in the industrial actuation and flow control markets means that customers can rely on us to understand their problems and to deliver reliable, economic solutions. Rotork's talented and experienced engineers have an in-depth understanding of the problems that are faced in the field and they know how to fix them.

On sites where providing evidence of valid asset certification is a legal requirement, Rotork engineers can carry out the necessary OEM level inspections and provide the statutory paperwork to comply with regulations.

- Field support
- Planned shutdown support
- Actuator workshop overhaul
- Valve automation services
 - On-site
 - Off-site
- Global support



rotork®



www.rotork.com

A full listing of our worldwide sales and service network is available on our website.

Rotork plc
Brassmill Lane, Bath, UK
tel +44 (0)1225 733200
email mail@rotork.com

PUB089-001-00
Issue 01/24

As part of a process of on-going product development, Rotork reserves the right to amend and change specifications without prior notice. Published data may be subject to change. For the very latest version release, visit our website at www.rotork.com

The name Rotork is a registered trademark. Rotork recognises all registered trademarks. The Bluetooth® word mark and logos are registered trademarks owned by Bluetooth SIG, Inc. and any use of such marks by Rotork is under license. Published and produced in the UK by Rotork. POLB0123