

SM-1020-0144 Electronic Actuator for HART Communication

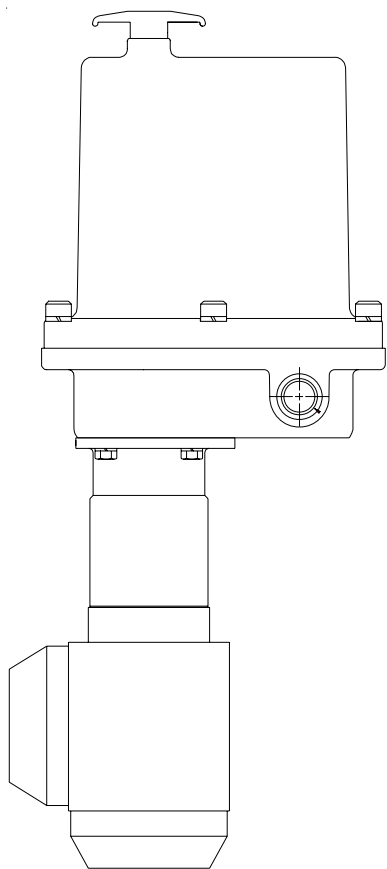

Table of Contents

General Information	2-3
Product Specifications	4
Installation Wiring	5
Setup Information	5-7
Recommended Spare Parts List	7
Typical Wiring Diagram	8
Troubleshooting Guide	9
Component Location Drawing	10
Major Dimensions	11

Due to wide variations in the terminal numbering of actuator products, actual wiring of this device should follow the print supplied with the unit.

GENERAL INFORMATION

INTRODUCTION

Jordan Controls, Inc., designs, manufactures, and tests its products to meet many national and international standards. For these products to operate within their normal specifications, they must be properly installed and maintained. The following instructions must be followed and integrated with your safety program when installing, using and maintaining Jordan Controls products:

- Read and save all instructions prior to installing, operating and servicing this product.
- If you do not understand any of the instructions, contact your Jordan Controls representative for clarification.
- Follow all warnings, cautions and instructions marked on, and supplied with, the product.
- Inform and educate personnel in the proper installation, operation and maintenance of the product.
- Install equipment as specified in Jordan Controls installation instructions and per applicable local and national codes. Connect all products to the proper electrical sources.
- To ensure proper performance, use qualified personnel to install, operate, update, tune and maintain the product.
- When replacement parts are required, ensure that the qualified service technician uses replacement parts specified by Jordan Controls. Substitutions may result in fire, electrical shock, other hazards, or improper equipment operation.
- Keep all product protective covers in place (except when installing, or when maintenance is being performed by qualified personnel), to prevent electrical shock, personal injury or damage to the actuator.

WARNING

Before installing the actuator, make sure that it is suitable for the intended application. If you are unsure of the suitability of this equipment for your installation, consult Jordan Controls prior to proceeding.

WARNING - SHOCK HAZARD

Installation and servicing must be performed only by qualified personnel.

WARNING - ELECTROSTATIC DISCHARGE

This electronic control is static-sensitive. To protect the internal components from damage, never touch the printed circuit cards without using electrostatic discharge (ESD) control procedures.

The MERLA FCV is a socket weld valve. Never weld on the valve with the actuator electrically connected.

RECEIVING/INSPECTION

Carefully inspect for shipping damage. Damage to the shipping carton is usually a good indication that it has received rough handling. Report all damage immediately to the freight carrier and Jordan Controls, Inc.

Unpack the product and information packet—taking care to save the shipping carton and any packing material should return be necessary. Verify that the items on the packing list or bill of lading agree with your own.

STORAGE

If the product will not be installed immediately, it should be stored in a clean, dry area where the ambient temperature is not less than -20° F. The actuator should be stored in a non-corrosive environment. The actuator is not sealed to NEMA 4 until the conduit entries are properly connected.

EQUIPMENT RETURN

A Returned Goods authorization (RG) number is required to return any equipment for repair. This must be obtained from Jordan Controls. (Telephone: 414/461-9200) The equipment must be shipped, freight prepaid, to the following address after the RG number is issued:

Jordan Controls, Inc.
5607 West Douglas Avenue
Milwaukee, Wisconsin 53218
Attn: Service Department

To facilitate quick return and handling of your equipment, include:

RG Number on outside of box
Your Company Name, Contact Person, Phone/Fax No.
Address
Repair Purchase Order Number
Brief description of the problem

GENERAL INFORMATION

IDENTIFICATION LABEL

An identification label is attached to each actuator cover. When ordering parts, requesting information or service assistance, provide all of the label information.

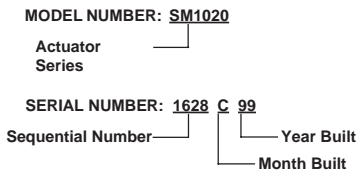

GENERAL ACTUATOR DESCRIPTION

The HART SM-1020 is a full-featured rotary actuator that communicates with master controllers using the HART (Highway Addressable Remote Transducer) field communication protocol. The HART protocol allows commands, position feedback, and diagnostics to be sent digitally across one pair of current loop wires. Up to 15 actuators, transmitters and other field instruments may be connected to one HART current loop. HART is an open standard supported by the HART Communication Foundation.

The design provides smooth, highly accurate positioning. These rugged actuators may be mounted in any position and will withstand the most adverse environmental conditions. The actuator goes into low-power standby-mode at idle.

A stepper motor produces torque, which is transmitted to the output shaft through a gear train. The built-in servo drive amplifier controls the stepper motor's speed and direction. It also controls actuator end limits, motor torque, deadband and HART communication and setup.

ABBREVIATIONS USED IN THIS MANUAL

A or Amps	Ampere
ac	Alternating Current
AWG	American Wire Gauge
° C	Degrees Celsius
CW	Clockwise
CCW	Counterclockwise
dc	Direct Current
DEC	Decrease
DIP	Dual Inline Package (DIP Switch)
ESD	Electro-static Discharge
° F	Degrees Fahrenheit
hp	Horsepower
IN	Inch
INC	Increase
in.lbs.	Inch Pounds
kg	Kilogram
L	Line (power supply)
lbf	Pounds Force
lbs	Pounds
LED	Light Emitting Diode
LOS	Loss of Signal
LS	Limit Switch
mA	Milliamp
mm	Millimeters
-	Negative
N	Newton (force)
N	Neutral (power supply)
Nm	Newton Meter
NPT	National Pipe Thread
PCB	Printed Circuit Board
Pot	Potentiometer
+	Positive
RPM	Revolutions per Minute
SEC	Second
TB	Terminal Strip
Vac	Volts ac
Vdc	Volts dc

WARRANTY INFORMATION

Warranty: Subject to the following, Jordan expressly warrants the products manufactured by it as meeting the applicable Jordan product specifications and that such products are free from defects in material and workmanship for a period of one (1) year from the date of delivery. The foregoing is the sole and exclusive warranty made by Jordan with respect to the products. Jordan makes no other warranties, either express or implied (including, without limitation, warranties as to merchantability or fitness for a particular purpose). The purchaser retains responsibility for the application and functional adequacy of the offering. See Jordan's General Conditions of Sale - Product, for complete warranty information.

SM-1020-0144 PRODUCT SPECIFICATIONS

ELECTRICAL:

Supply Voltage: 24 Vdc +/- 20%

Operating Current: 2 amperes maximum; 1.5 amperes at 24 Vdc input, 10mA in standby when actuator is at null

Power: 36 VA; (≤ 02 A), 10 mA current at idle

Command Signal Inputs: HART protocol on locked 4 mA current loop for multidrop applications

Limit Signals:

Internal: Part of servo control

Position Feedback Signal:

HART protocol on locked 4 mA current loop

Terminations: PC board mounted terminal blocks accepting up to #14 AWG solid or stranded copper wire.

PC Boards: Total of two: Upper power supply board; lower logic board

Duty Cycle: Continuous modulating duty

Manual Operation: Field configurable

VALVE MOUNT:

Valve: Mount supplied for MERLA FCV valve

Material: Machined from extruded aluminum and anodized

Finish: Gray epoxy coating over anodized finish

Hardware: Stainless steel. All needed hardware supplied.

Torque Required: 125 in. lb. per MERLA catalog

Full Stroke: 4.6 turns (1/2-13 stem thread) as measured

Stem Rise: 0.35 inch as measured

MECHANICAL:

Output Shaft Motion: CW on increasing command facing output shaft. CCW on decreasing command

Output Torque: 125 in. lb. maximum

Output Shaft Speed: 3.3 rpm (90 seconds full stroke on 4.6 turn MERLA valve)

Maximum Turns: Maximum 5 output shaft turns (Factory set at 4.6 turns)

Storage Temperature: -40° to 85°C (-40° 185°F)

Ambient Operating Temperature:

4° to 70°C (39° to 158°F)

Enclosure: Gray epoxy coating over gray anodized finish. Waterproof and corrosion resistant finish, aluminum or stainless steel external parts. Local manual operating handwheel, rotates when actuator is moving. Designed for Class 1, Div 1, Group C & D 'explosion proof' service.

Repeatability: 1.5% of full range

Positioning Accuracy: 1.5% of full range or better

Other:

- Output shaft locks-in-place on loss of power
- Output shaft locks-in-place on loss of HART signal
- All internal hardware is stainless steel or aluminum

Weight:

SM-1020: 16 lbs. (7.3 kg)

Conduit Entry: Two 1/2-14 NPT

Handwheel: Rotates when actuator is moving

INSTALLATION WIRING

GENERAL

All wiring should be done in accordance with prevailing codes by qualified personnel.

A typical wiring diagram is shown on page 8. **Actual wiring should follow the print supplied with the actuator.** Fusing must be installed in line power, and should be of the slow blow type. Recommend 5 amp for dc input.

Wiring should be routed to the actuator through one of the two 1/2 inch conduit openings. One conduit will contain input power and earth ground wires. The other will contain low level input and output signal wiring. **It is required that all low level signal wiring be a shielded type with the shield grounded at source common.**

After installation, all conduits **must be sealed** to prevent water damage and to maintain explosion proof integrity. Follow FM requirements.

Maximum recommended wire size is 14 AWG, and minimum is 20 AWG.

WIRING TO TB1

Input power terminates at TB1. Terminal 7 is positive (+), and terminal 8 is negative (-).

HART command wires terminate at terminal 2 (-) and to terminal 1 (+).

The incoming power supply earth ground should be securely connected to the green ground screw located inside the actuator base between the two conduit entries, per FM requirements.

SETUP INFORMATION

MECHANICAL SETUP

1. Ensure valve stem is turned to its full closed position. (Full CW looking at top of stem)
2. Slip coupling furnished with actuator onto the valve stem with slotted end facing up. DO NOT install the set screw at this time.
3. Temporarily install the actuator onto the valve yoke in the desired mechanical orientation ensuring actuator output shaft drive pin aligns with the coupling slot.
4. Temporarily install one of the three 3/8-16 x 0.50 long cone point set screws and tighten only enough to support the actuator onto the valve.
5. Match mark the actuator valve adaptor and valve for subsequent re-assembly.
6. Proceed with startup.

AMPLIFIER SETUP

Communication with HART Handheld Programmer

1. Connect load resistor to a single HART actuator. Set SW1 to MAN position. Connect power to actuator. Press S1 (DEC) to verify actuator rotates CCW. Release S1. Press S2 (INC) to verify actuator rotates CW and runs smoothly. Release R2.
2. Connect HART handheld programmer across the HART load resistor. Turn on programmer. After programmer completes searching for HART devices, select the actuator.
3. Select process variables to display position, setpoint and temperature. Press S1 (DEC). Observe that the position value decreases. Release S1. Press S2 (INC). Observe that the position value increases.
4. Set SPAN and ZERO as needed for proper actuator operation on your process.

CALIBRATION AND START-UP

The SM-1020-0144 can be calibrated either remotely using the handheld calibrator connected to the HART network, or locally through the board-mounted INC & DEC switches. Before starting this procedure, the actuator should be connected to a HART controller and not mounted to the valve. The handheld calibrator should be connected to the Hart loop and should have found the actuator needed to calibrate.

1. Close the valve manually.
2. Using the handheld unit, re-initiate the ZERO and SPAN to the factory default values.
3. Use the handheld unit or the close (DEC) button on the board to move the actuator to 10% open.
4. Mount the actuator to the valve following the *Mechanical Setup Procedures*. If it is necessary to align the pin with the valve shaft, move the actuator or valve shaft toward the open direction.
5. Move the actuator toward the close position a step at a time by using the board mounted (DEC) switch or by using the handheld calibrator set at a 1% step size, until the actuator stall; then increase the position one step.
6. Verify that the flow is "0". If not manually move the actuator until the flow indicator is zero.
7. Confirm this position as the "zero" using the handheld unit. Write the "counts" number displayed on the handheld unit for future reference.
8. Using the handheld unit, command the actuator to the 100% position. Verify that the actuator does not stall before reaching the 100% position. If it does, move the actuator to the close position a step. Establish this as the SPAN position with the handheld.

SETUP INFORMATION

HART Command Set - Universal Commands

Command		Data in Command		Data in Reply	
Nbr.	Function	Byte	Function	Byte	Function
0	Read Unique Identifier		None	0 1 2 3 4 5 6 7 8 9-11	“254” (expansion) manufacturer identification code manufacturer’s device type code number of preambles universal command revision transmitter specific command revision software revision hardware revision device function flags device ID number
1	Read Primary Variable		None	0 1-4	Position Units Code Position (Float)
2	Read Current and Percent of Range		None	0-3 4-7	Current in mA (Float) Percent of Range (Float)
3	Read Current and Dynamic Variables		None	0-3 4 5-8 9 10-13 14 15-18	Current in mA (Float) Position Units Code Position (Float) Setpoint Units Code Setpoint (Float) Temperature Units Code Temperature (Float)
6	Write Polling Address	0	Polling Address (Byte)	0	Polling Address (Byte)
11	Read Unique Identifier Associated with Tag	0-5	Tag (Packed ASCII)	0-5	Tag (Packed ASCII)
12	Read Message		None	0-23	Message (Packed ASCII)
13	Read Tag, Descriptor, Date		None	0-5 6-17 18-20	Tag (Packed ASCII) Descriptor (Packed ASCII) Date (Date)
14	Read PV Sensor Information		None	0-2 3 4-7 8-11 12-15	Unused Endpoints units code (Byte) Endpoint 1 (Float) Endpoint 0 (Float) Minimum Span (Float)
15	Read Output Information		None	0 1 2 3-6 7-10 11-14 15 16	Unused Unused Span and Zero units code Span (Float) Zero (Float) Unused (Float) Write-Protect Code Unused
16	Read Final Assembly Number		None	0-2	Final Assembly Number
17	Write Message	0-23	Message (Packed ASCII)		
18	Write Tag, Descriptor, Date	0-5 6-17 18-20	Tag (Packed ASCII) Descriptor (Packed ASCII) Date (Date)	0-5 6-17 18-20	Tag (Packed ASCII) Descriptor (Packed ASCII) Date (Date)
19	Write Final Assembly Number	0-2	Final Assembly Number	0-2	Final Assembly Number

SETUP INFORMATION

HART Command Set - Common Practice Commands

Command		Data in Command		Data in Reply	
Nbr.	Function	Byte	Function	Byte	Function
35	Write Range Values	0 1-4 5-8	Range units code SPAN = upper range value (Float) ZERO = lower range value (Float)		As in command
38	Reset Configuration Changed Flag		None		none
48	Read additional transmitter status		None	0-23	Additional status
59	Write number of response preambles	0	Number of response preambles		As in command

HART Command Set - Device Specific Commands

Command		Data in Command		Data in Reply	
Nbr.	Function	Byte	Function	Byte	Function
128	Read materials		none	0 1 2 3 4 5 6 7	Actuator series Force range Voltage input Stroke range Gearbox option Signal interface Battery backup option Factory service option
131	Read setup variable	0	Setup variable index	0 1 2-5	Setup variable index Setup variable units code Setup variable (Float)
132	Write setup variable	0 1 2-5	Setup variable index Setup variable units code Setup variable (Float)	0 1 2-5	Setup variable index Setup variable units code Setup variable (Float)
135	Command configuration change		none		none
136	Restore factory setup		None		none

RECOMMENDED SPARE PARTS LIST

<u>PART NUMBER</u>	<u>DESCRIPTION</u>	<u>PART NUMBER</u>	<u>DESCRIPTION</u>
74B-010957-162	Cover O-Ring	17B-003813-009	Output shaft bearing
18B-	Output shaft bushing	16B-032189-001	Motor pinion gear
19B-003815-060	Output shaft seal	61A-037543-001	Handwheel shaft
61B-036257-001	Feedback nut 7/8 acme, bronze	58B-024244-394	Handwheel shaft seal
62B-036764-001	Output shaft, 7/8 acme	70C-039131-001	PC board set

TYPICAL WIRING DIAGRAM

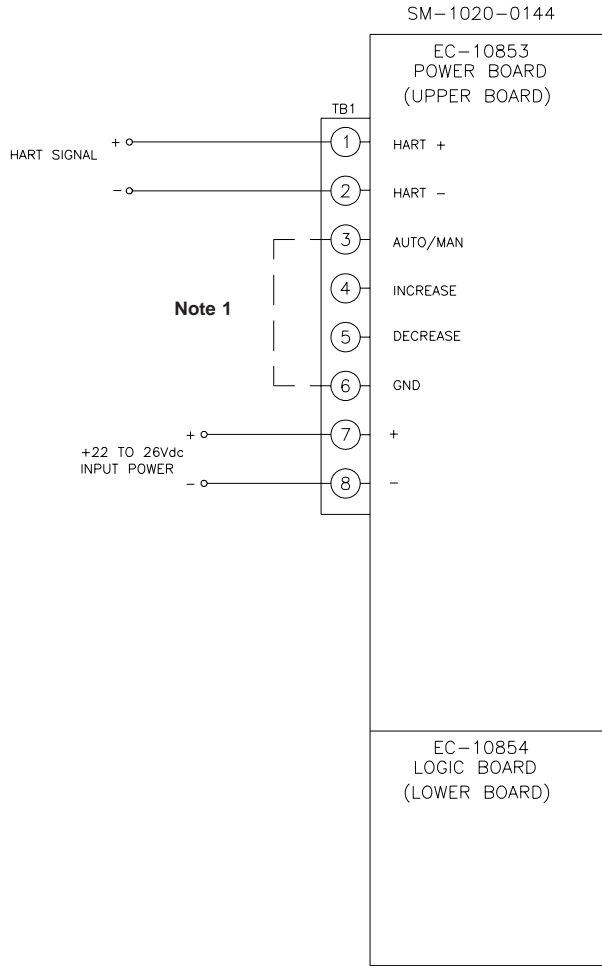

Due to wide variations in the terminal numbering of actuator products, actual wiring should follow the print supplied with the actuator.

Note 1:
Customer supplied jumper wire to be used when remote auto manual operation is needed. HART communication will be disabled.

MULTIDROP OPERATION

MULTIPLE HART ACTUATORS WITH LOOP POWERED HART TRANSMITTERS

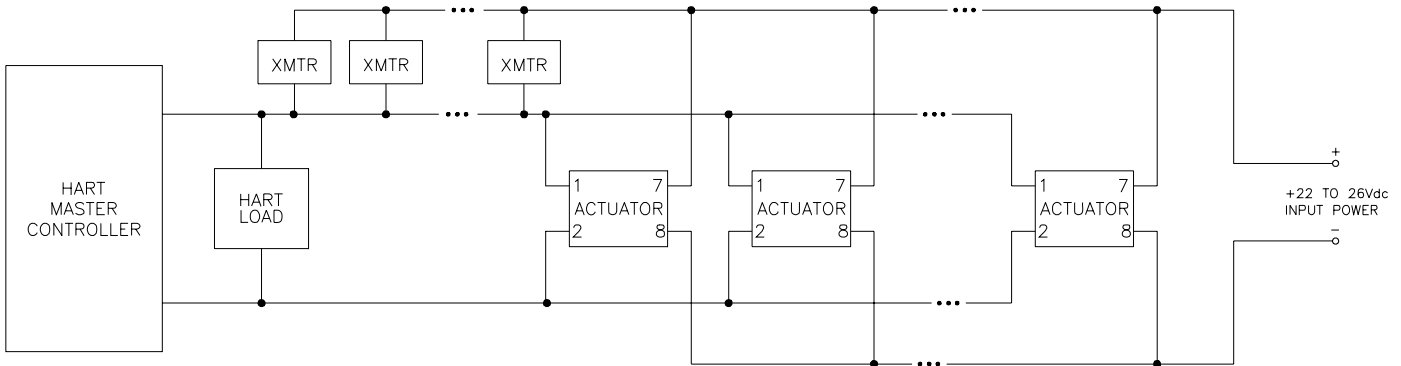

TROUBLESHOOTING GUIDE

TROUBLE	POSSIBLE CAUSE	REMEDY
Can't get full actuator travel.	a. Run into a mechanical stop.	a. Set stroke within actuator limits.
	b. Actuator ZERO & SPAN calibration incorrect.	b. Calibrate ZERO & SPAN.
Output shaft goes in opposite direction as desired.	Actuator ZERO & SPAN calibration incorrect.	Calibrate ZERO & SPAN.
No response when in manual mode.	a. 24 V input power not present.	a. Connect 24 V input power.
	b. SW1 not in manual.	b. Place SW1 in manual position.
Actuator "chatters" and INC, DEC LEDs go on and off.	Deadband too tight.	Set deadband to a higher value using the HART Communications Device.
Erratic operation.	Incorrect wiring.	Correct wiring.
Actuator won't run.	a. No power or power out of range.	a. Check and restore power or connect to proper power.
	b. ESD damage to PC boards.	b. Replace PC board set.
	c. Incorrect wiring.	c. Correct wiring.
	d. Loss of HART signal.	d. Restore HART signal.
	e. Excessive side load on output shaft.	e. Eliminate side load.
	f. DC input power polarity reversed.	f. Correct wiring.
	g. Command signal not received or not in range.	g. Check and correct.
	h. Actuator mechanically at end of travel.	h. Recalibrate to bring into mechanical range.
	i. External actuated device binding or at its end of travel.	i. Eliminate bind or recalibrate.
Actuator won't go into standby mode.	a. Deadband set too small.	a. Change deadband setting.
	b. Actuator in manual.	b. Switch SW1 into the Auto position.
	c. No HART Communication.	c. Establish HART Communication.
Actuator communicates with HART, but will not position.	a. Incorrect setting of SPAN/ZERO/DEADBAND.	a. Calibrate ZERO and SPAN.
	b. Actuator in Manual.	b. Switch SW1 into Auto.

MAJOR COMPONENT IDENTIFICATION

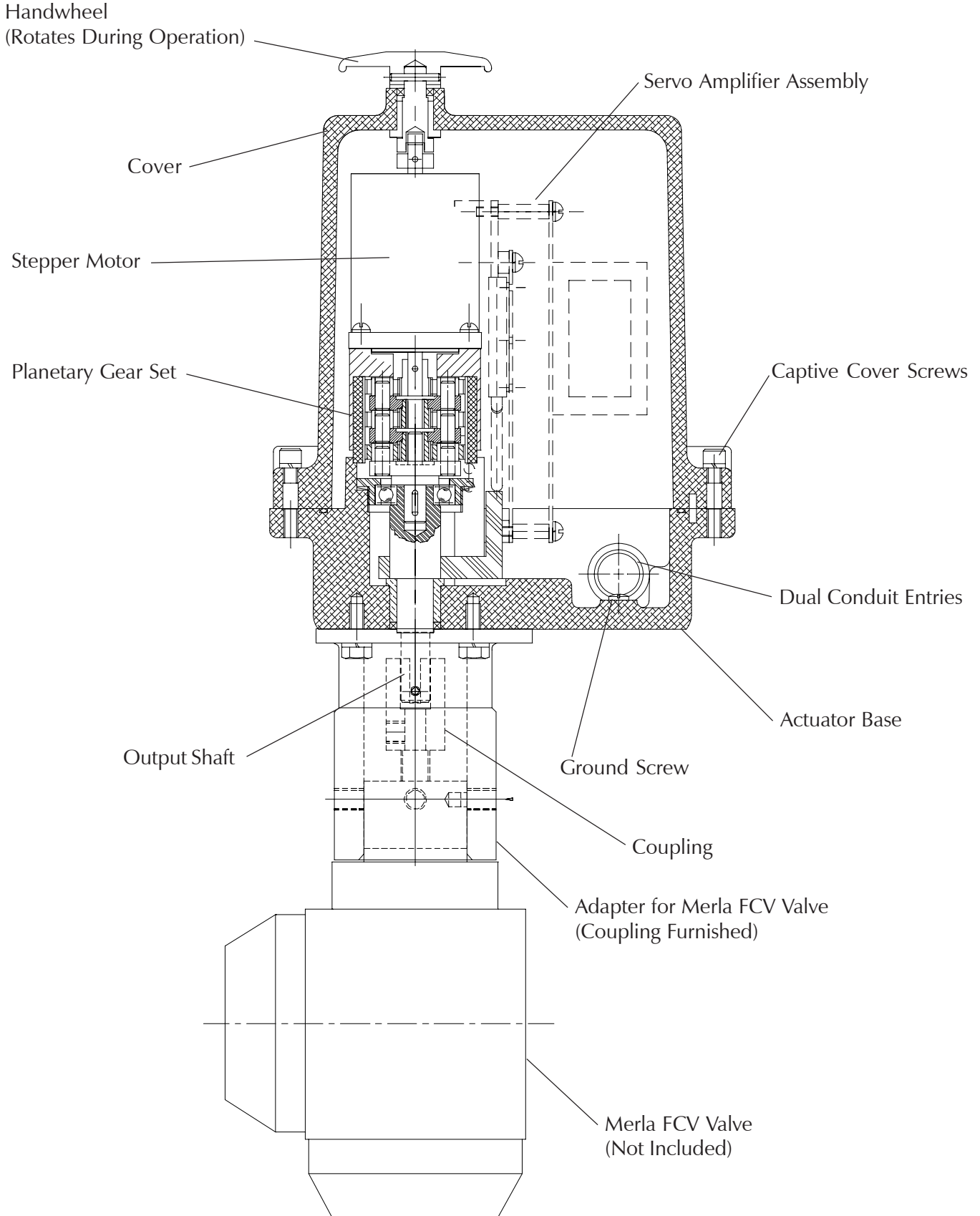

INSTALLATION DIMENSIONS

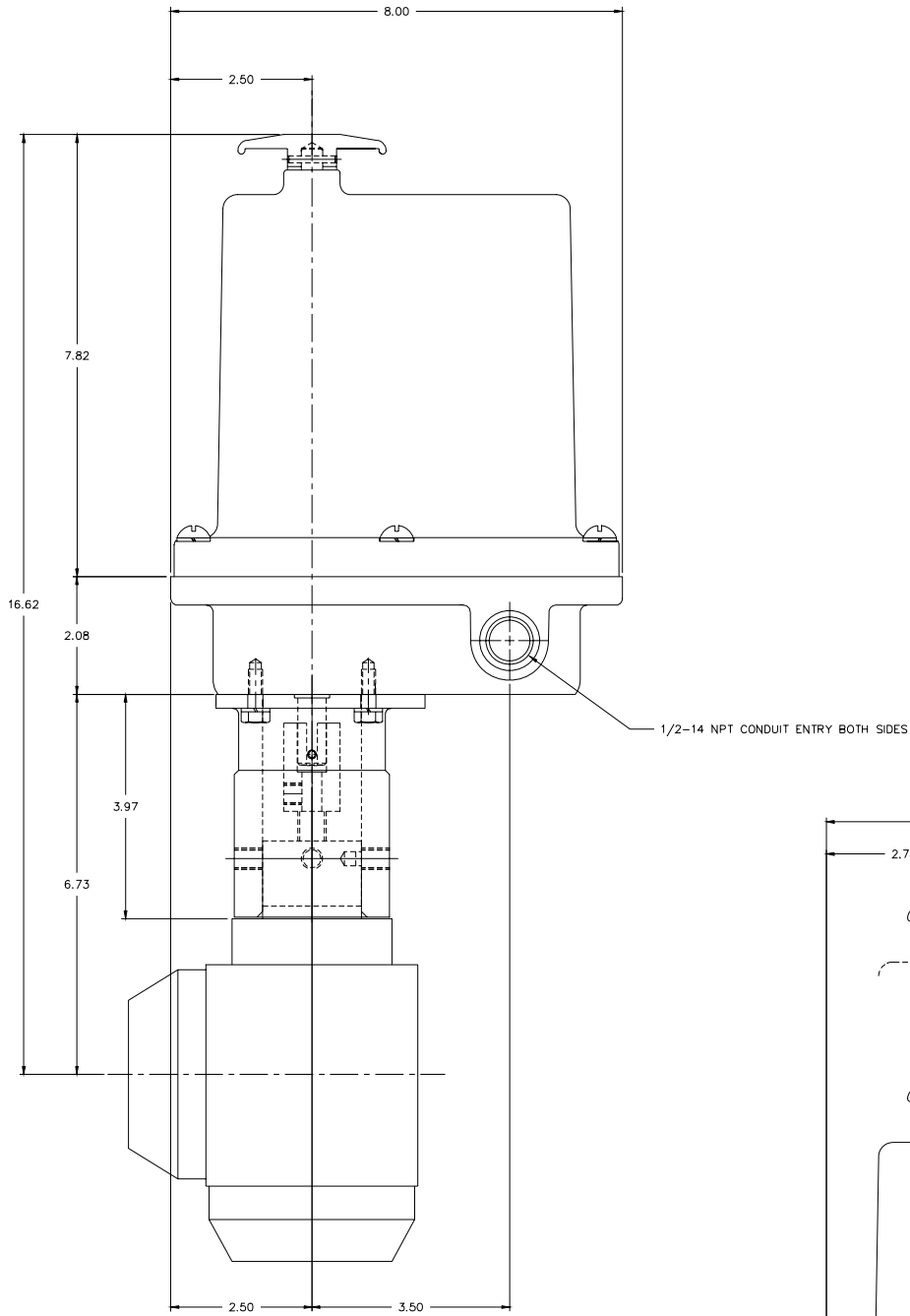

NEVER WELD ON VALVE WITH ACTUATOR MOUNTED.

All Dimensions in Inches

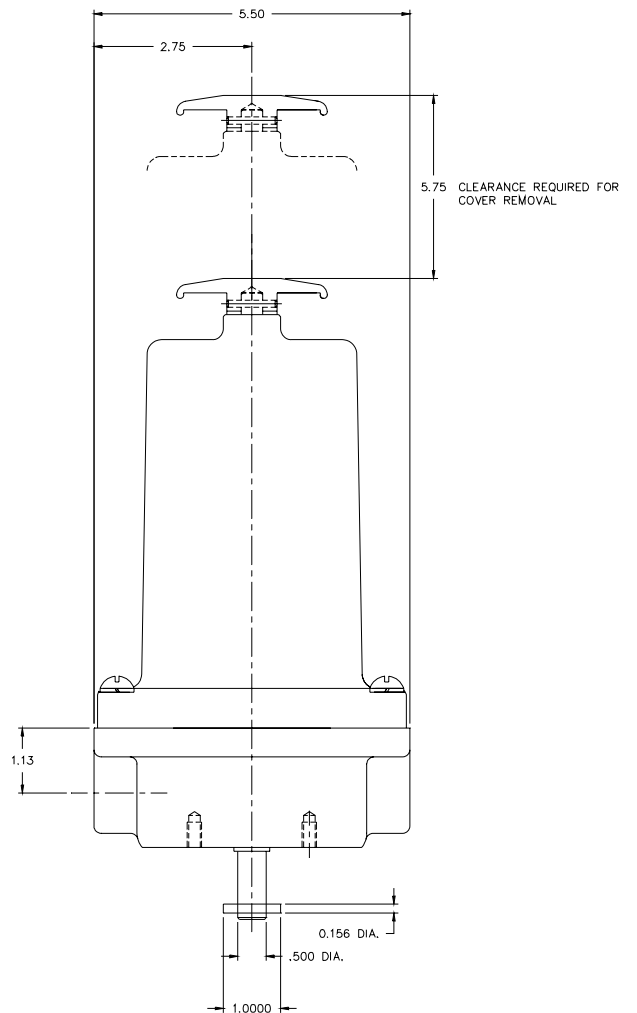

JORDAN CONTROLS, INC.
5607 West Douglas Avenue
Milwaukee, Wisconsin 53218
Phone: (414) 461-9200
FAX: (414) 461-1024
E-Mail: jordan@jordancontrols.com
www.jordancontrols.com
IM-06309 2/00

The dimensions in this manual are subject to change without notice and should not be used for preparation of drawings or fabrication of installation mounting. Current installation dimension drawings are available upon request.

