

# **rotork<sup>®</sup>**

## **Process Controls**



### **SM-1600 Series**

#### **Installation Manual**

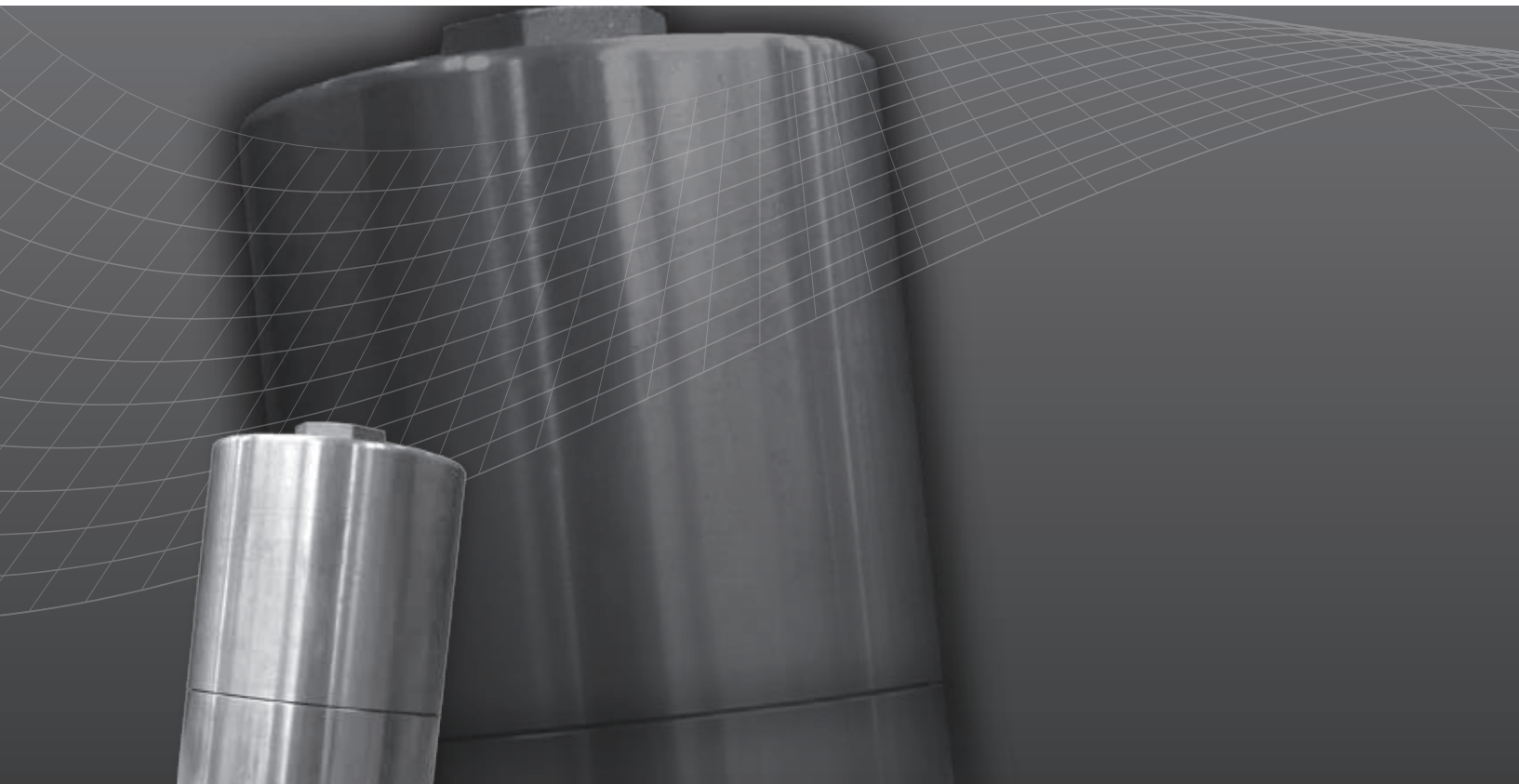

**Linear Actuators**

**Established Leaders in Flow Control**

## Contents

# rotork® Process Controls

Section	Page	Section	Page
Introduction	3	Actuator Troubleshooting guide SM-1630-N, SM-1650-N & SM-1680-N	17
General Information	4-5	Amplifier Troubleshooting	18
Maintenance	5	Installation Dimensions	19
Product Identification	6	DIP Switch Charts	20
Actuator Specifications	7	Parts Identification	21-28
Actuator Installation	8		
Field Wiring	9		
Typical Wiring Diagrams	10-11		
Amplifier Specifications AD-8240 for SM-1630-D & SM-1650-D	12		
Actuator Startup for SM-1630-D & SM-1650-D	13		
Amplifier Specifications SM-1680-D	14		
Actuator Startup for SM-1680-D	15		
Actuator Startup SM-1630-N, SM-1650-N & SM-1680-N	16		



**THIS MANUAL CONTAINS IMPORTANT SAFETY INFORMATION. PLEASE ENSURE IT IS THOROUGHLY READ AND UNDERSTOOD BEFORE INSTALLING, OPERATING OR MAINTAINING THE EQUIPMENT.**

**DUE TO WIDE VARIATIONS IN THE TERMINAL NUMBERING OF ACTUATOR PRODUCTS, ACTUAL WIRING OF THIS DEVICE SHOULD FOLLOW THE PRINT SUPPLIED WITH THE UNIT.**

# Introduction

Rotork Process Controls designs, manufactures, and tests its products to meet many national and international standards. For these products to operate within their normal specifications, they must be properly installed and maintained.

The following instructions must be followed and integrated with your safety program when installing and using RPC products:

- Read and save all instructions prior to installing, operating and servicing this product.
- If you don't understand any of the instructions, contact Rotork Process Controls for clarification.
- Follow all warnings, cautions and instructions marked on, and supplied with, the product.
- Inform and educate personnel in the proper installation, operation and maintenance of the product.
- Install equipment as specified in Rotork Process Controls installation instructions and per applicable local and national codes. Connect all products to the proper electrical sources.
- To ensure proper performance, use qualified personnel to install, operate, update and maintain the unit.
- When replacement parts are required, ensure that the qualified service technician uses replacement parts specified by Rotork Process Controls. Substitutions may result in fire, electrical shock, other hazards, or improper equipment operation.
- Keep all product protective covers in place (except when installing, or when maintenance is being performed by qualified personnel), to prevent electrical shock, personal injury or actuator damage.
- Operation of actuator in an inappropriate fashion may cause harm or damage to unit or other equipment surroundings.



# General Information

## INTRODUCTION

Rotork Process Controls designs, manufactures, and tests its products to meet national and International standards. For these products to operate within their normal specifications, they must be properly installed and maintained. The following instructions must be followed and integrated with your safety program when installing, using, and maintaining Rotork Process Controls products:

Read and save all instructions prior to installing, operating, and servicing this product. If any of the instructions are not understood, contact your Rotork Process Controls representative for clarification.

Follow all warnings, cautions, and instructions marked on, and supplied with, the product. Inform and educate personnel in the proper installation, operation, and maintenance of the product.

Install equipment as specified in Rotork Process Controls installation instructions and per applicable local and national codes. Connect all products to the proper electrical sources. To ensure proper performance, use qualified personnel to install, operate, update, tune, and maintain the product.

When replacement parts are required, ensure that the qualified service technician uses replacement parts specified by Rotork Process Controls. Substitutions may result in fire, electrical shock, other hazards, or improper equipment operation.

### **WARNING**

**Before installing the actuator, make sure that it is suitable for the intended application. If you are unsure, consult Rotork Process Controls prior to proceeding.**

### **WARNING: ELECTRIC SHOCK HAZARD**

**Installation and servicing must be performed only by qualified personnel.**

### **WARNING: ELECTROSTATIC DISCHARGE**

**This electronic control is static-sensitive. To protect the internal components from damage, never touch the printed circuit cards without using electrostatic discharge (ESD) control procedures.**

## GENERAL ACTUATOR DESCRIPTION

The SM-1600 Series Rotary actuators are self contained, bi-directional electrically operated devices with a maximum gear train rating of 1000 in.lbs. The drive motor may be AC or DC. The unit may contain position feedback, limit switches, motor brake, anti-condensation heater and thermostat, manual handcrank and built-in amplifier.

The positioning range with selected feedback gear ratios will control the output shaft from 72° to 324 revolutions. The actuator is permanently lubricated and may be mounted in any position.

## RECEIVING / INSPECTION

Carefully inspect for shipping damage. Damage to the shipping carton is usually a good indication that it has received rough handling. Report all damage immediately to the freight carrier and Rotork Process Controls, Inc.

Unpack the product and information packet taking care to save the shipping carton and any packing material should return be necessary. Verify that the items on the packing list or bill of lading agree with your own documentation.

## STORAGE

If the product will not be installed immediately, it should be stored in a clean, dry area where the ambient temperature is -13 to 131 °F (-25 to 55 °C). The actuator should be stored in a non-corrosive environment. The actuator is not sealed to NEMA 4 until the conduit entries are properly connected.



# General Information

## MAINTENANCE

Rotork Process Controls actuators are maintenance free. It is recommended that you remove the cover and visually inspect the actuator on an annual basis.

Maintenance must be performed only by qualified personnel. Voltages hazardous to your health are applied to these actuators. De-energize all sources of power before removing actuator cover. Failure to follow these precautions may result in serious injury or death. ATEX approved actuators must be repaired and overhauled in accordance with EN 60079-19, Electrical apparatus for explosive atmospheres, Part 19. Repair and overhaul for apparatus used in explosive atmospheres (other than mines).

*Lubrication:* The gearing is permanently lubricated. Re-lubrication is only required during repairs to the power gearing. The bronze bushings are lubricated with a few drops of SAE-10 or 20 NON-DETERGENT oil. Re-lubricate when repairs are made.

## EQUIPMENT RETURN

A Returned Goods authorization (RG) number is required to return any equipment for repair. This must be obtained from Rotork Process Controls. (Telephone: 414/461-9200) The equipment must be shipped, freight prepaid, to the following address after the RG number is issued:

Rotork Process Controls, Inc.  
5607 West Douglas Avenue  
Milwaukee, Wisconsin 53218  
Attn: Service Department

To facilitate quick return and handling of your equipment, include:

1. RG Number on outside of box
2. Your Company Name, Contact Name, Phone/Fax
3. Address
4. Repair Purchase Order Number
5. Brief description of the problem

## ABBREVIATIONS USED IN THIS MANUAL

A	Ampere
AC	Alternating Current
°C	Degrees Celsius
CW	Clockwise
ACW	Anti-clockwise
CCW	Counter-clockwise
DC	Direct Current
°F	Degrees Fahrenheit
G	Earth Ground
Hz	Hertz
in. lbs	Inch Pounds
kg	Kilogram
L	Line (power supply)
lbs	Pounds Force
LVDT	Linear Variable Differential Transformer
mA	Milliamp
mfd	Microfarad
mm	Millimeters
N	Newton (force)
NEMA	National Electrical Manufacturing Association
Nm	Newton Meter
NPT	National Pipe Thread
PCB	Printed Circuit Board
PH	Phase
PL	Position Limit switch
RPM	Revolutions per Minute
SEC	Second
SPDT	Single Pole Double Throw
TL	Torque Limit Switch
V	Volts
VA	Volt Amps
VAC	Volts AC
VDC	Volts DC
VFD	Vacuum Fluorescent Display
VR	Variable Resistance
W	Watt

## WARRANTY INFORMATION

**Warranty:** Subject to the following, Rotork Process Controls expressly warrants the products manufactured by it as meeting the applicable Rotork Process Controls product specifications and that such products are free from defects in material and workmanship for a period of one (1) year from the date of delivery. The foregoing is the sole and exclusive warranty made by Rotork Process Controls with respect to the products. Rotork Process Controls makes no other warranties, either express or implied (including, without limitation, warranties as to merchantability or fitness for a particular purpose). The purchaser retains responsibility for the application and functional adequacy of the offering. See Rotork Process Controls's General Conditions of Sale - Product, for complete warranty information.

# Product Identification

## IDENTIFICATION LABEL

An identification label is attached to each actuator. When ordering parts, requesting information or service assistance, please provide all of the label information. **You must supply the serial number with all enquiries.**

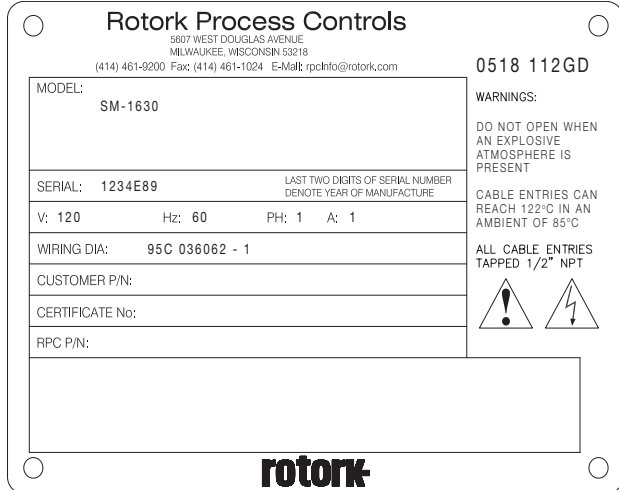

Figure 1.1. Actuator identification label.

## OUTPUT SHAFT TURNS

The last number in the CODE indicates the nominal Output Shaft Turns for the range of the feedback gearing in the actuator.

Nominal Output Shaft Turns are given as if the unit is built with cam activated position limit switches and/or a 1 turn feedback potentiometer.

If the unit is built with a multi-turn switch assembly and/or a 10 turn potentiometer, the nominal output shaft turns range is 12 times the turns indicated by the code number.

Example:

**Note:**  
Model number for actuators with built-in amplifier.

**MODEL NUMBER: SM-1630/AD-8240**

Model number of built-in amplifier

**MODEL** SM-1630  
**SERIAL** 1234E89  
**V/Hz/V/A** 120/60/1/1

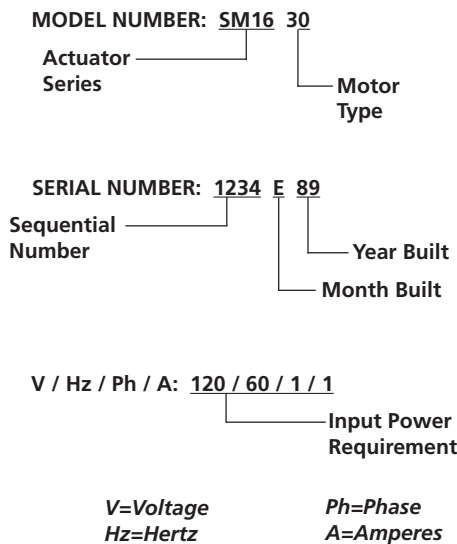

# Actuator Specifications

- **Standard Line Voltage:** 120 VAC, 1 Phase, 50/60 Hz  
240 VAC, 1 Phase, 50/60 Hz  
24 VDC
- **Command Signal Inputs:** 4-20 mA  
0-5 VDC  
0-10 VDC
- **Position Feedback Signal:** 1000 ohm potentiometer or  
4-20 mA
- **Field Wiring Terminations:** Plugable terminal block,  
wire size range 26-14 AWG
- **Torque Range:** 500 to 1000 in.lbs.
- **Speed:** 2.5 to 5 rpm
- **Rotation:** Between 72° and 324 turns
- **Weight:** (Not including devices  
mounted to actuator)  
15-22 lbs. (6.8-10 kg)
- **Conduit Entry:** 1/2 NPT or M20.
- **Temperature Limits:** -40 to 150 °F (-40 to 65 °C)
- **Vibration Limits:** 4-15 Hz @ 0.5 ± 0.1 mm  
amplitude maximum
- **Humidity:** 80% maximum at  
87 °F (31 °C)
- **Altitude:** Up to 6,560 ft. (2000 m)  
above mean sea level
- **Pollution Degree:** 2
- **Installation Category:** II
- **Enclosure:** NEMA Type 4 (IP65) indoor/  
outdoor, or hazardous  
locations for Class I,  
Division 1, Groups C and D,  
or Class II, Division 1,  
Groups E, F and G.

### Modulation Rate:

SM-1630-N & SM-1630-D: 2,000 starts/hour  
SM-1650-N & SM-1650-D: 2,000 starts/hour  
SM-1680-N: 4,000 starts/hour

Actuator Model	Input Power Volts / Phase / Hz	Current (Amps)		Command Input	Input Impedance (Ohms)	Feedback	Modulation Rate*
		Run	Stall				
SM-1630-N	120/1/50/60	0.9	1.2	N/A	N/A	N/A	2000 starts/hr
SM-1630-D	120/1/50/60	0.9	1.2	4-20 mA, 0-5 VDC or 0-10 VDC	200 100,000	1000 ohm pot or 4-20 mA	2000 starts/hr
SM-1650-N	240/1/50/60	0.45	0.5	N/A	N/A	N/A	2000 starts/hr
SM-1650-D	240/1/50/60	0.45	0.5	4-20 mA, 0-5 VDC or 0-10 VDC	200 100,000	1000 ohm pot or 4-20 mA	2000 starts/hr
SM-1680-N	24 VDC	5.2	6.25	N/A	N/A	N/A	4000 starts/hr
SM-1680-D	24 VDC	5.2	6.25	4-20 mA, 0-5 VDC or 0-10 VDC	200 100,000	1000 ohm pot or 4-20 mA	4000 starts/hr

# Actuator Installation

## ACTUATOR CHARACTERISTICS

- The actuator is permanently lubricated. It is not oil or grease filled and may be mounted in any position.
- The actuator weighs between 15 and 22 lbs. The weight of the actuator varies, depending upon the configuration of options selected.
- The actuator output shaft is made of stainless steel and the housing is aluminum.
- The keyway in the output shaft is not correlated in relation to the mounting holes, unless the customer has specified correlation at time of order.
- The actuator is a very efficient design and the output shaft may coast or be back-driven by the load if the actuator is not supplied with the optional motor brake.
- Enclosure Materials: The actuators are manufactured from alluminum alloy with stainless steel shafts, oilite bronze bushes and carbon steel fasteners. All external seals are manufactured from Nitrile which are suitable for use in an ambient temperature range of -40 to +85 °C. The user must ensure that the operating environment and any materials surrounding the actuator cannot lead to a reduction in the safe use of, or the protection afforded by, the actuator. Where appropriate the user must ensure the actuator is suitable protected against its operating environment.

## MOUNTING BRACKETS

- When designing mounting brackets and considering mounting locations, allow adequate clearance from the top of the actuator cover to any obstructions such as brick walls or steel structures that could interfere with cover removal.
- Consideration should be given for the location of the conduit entry as conduit will be connected to the actuator.
- If the actuator is supplied with a manual handcrank, allow for operator access.
- The standard SM-1600 series actuators are designed to be face mounted with three Grade 5 (or better) mounting bolts. The mounting holes are tapped 1/2 inch deep and the bolts selected must engage a minimum of 6 full threads (3/8").
- Care should be taken not to use bolt lengths that are too long which will bottom in the tapped holes. This will cause a loose mount and applying excessive torque to further tighten the bolts may damage the aluminum threads or shear the bolts.

## COUPLING THE OUTPUT SHAFT

- For maximum actuator life and efficiency, avoid side loading caused by incorrect shaft alignment. The use of solid, one piece couplings is not recommended.
- When coupling the actuator shaft to the driven shaft, select flexible couplings that can transfer the proper torque without any lost motion or the driven shaft may not be positioned as it should be in relation to the actuator's output shaft.
- The coupling end placed on the actuator's output shaft should be a slip fit. Avoid forcing or pounding the coupling onto the shaft as you may damage the actuator or the coupling.

## OVERHUNG LOADS AND END THRUST ON OUTPUT SHAFT

- Overhung loads on the actuator output shaft are limited to a maximum of 650 lbs. as measured from a point (center of keyway) 0.81 inches from the mounting face of the actuator.
- The maximum allowable end thrust applied to the output shaft is 780 lbs.

## ELECTRICAL SUPPLY REQUIREMENTS

- An overcurrent protective device is required for the supply power. Size the overcurrent device per requirements of actuator for 125% of maximum rated load.
- Disconnect for the supply power is to be supplied by the customer.
- Wire conductor type and size should match Rotork Process Controls' requirements, wiring diagrams and follow local codes.
- An overcurrent device must be placed near the actuator and it must be marked as the disconnecting means for the equipment.



## Field Wiring

### **WARNING - SHOCK HAZARD**

**Installation and servicing must be performed only by qualified personnel.**

De-energize all sources of power BEFORE removing the actuator cover. KEEP COVER TIGHT WHEN CIRCUITS ARE ALIVE. Voltages hazardous to your health are applied to these actuators. Failure to follow these precautions may result in serious injury or death.

EXPLOSIONPROOF and DUST-IGNITIONPROOF ACTUATORS are not explosionproof or dust-ignitionproof until final installation is complete. Hazardous location enclosures must be installed in accordance with The National Electric Code requirements as well as state and local codes

WATERTIGHT ACTUATORS are not watertight until final installation is complete with conduit entry sealed and actuator cover in place.

### **WARNING**

**All AC powered actuators contain single phase, 3 wire, permanent split capacitor motors. Motor power is applied across the motor common winding wire and one of the directional input wires. The capacitor creates a phase shift to the other motor directional input wire. This allows the motor to run and develop torque.**

With external input power applied to one winding, the opposite winding (energized by the capacitor) will have a voltage on it which is greater than the applied voltage while the motor is running. The voltage will be approximately 150 VAC for 120 VAC units and 300 VAC for 240 VAC units. Because of this characteristic the actuator directional input wires must never be connected in parallel from one actuator to another. No inductive or resistive load can be connected in parallel with the directional inputs. When operating more than one actuator from a common source, the use of isolated contacts between each actuator is required.

Wiring ac actuators in parallel without isolation will cause one of the actuators to operate at a reduced torque when an end of travel limit switch in the other actuator is opened. The actuator with the opened switch may continue to run, receiving power to the direction winding with the closed switch, by way of the power supplied from the actuator that has not reached its limit switch.

**END OF TRAVEL LIMIT SWITCHES** built into single phase, ac motor driven units are factory wired in series with the proper motor directional winding. When a switch is tripped (opened), motor power will be removed from the winding and the motor will stop.

### **FUSING IS NOT PROVIDED WITHIN THE ACTUATOR.**

Line fusing must be provided by the customer. Fuse rating should not exceed 5 amperes and fuses should be motor type. Fusing must be near the actuator and it must be marked as the disconnecting means for the equipment

All installation must be in accordance with The National Electric Code requirements as well as state and local codes.

ATEX approved actuators must be installed in accordance with EN 60079-14, Electrical apparatus for explosive atmospheres, Part 14. Electrical installations in hazardous areas (other than mines).



# Wiring Diagram

## SM-1630-N & SM-1650-N

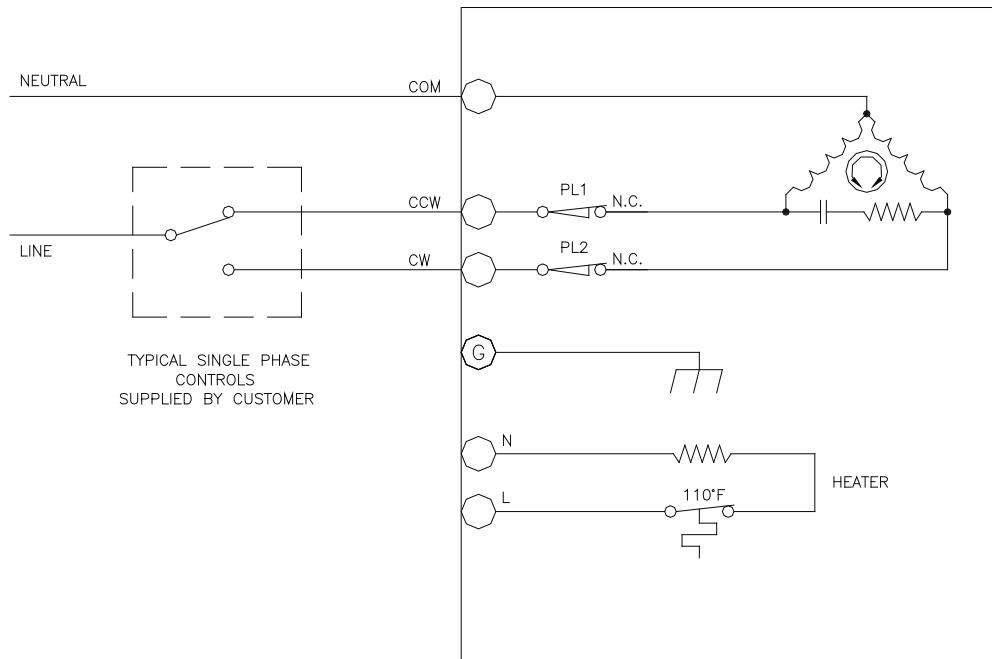

## SM-1680-N

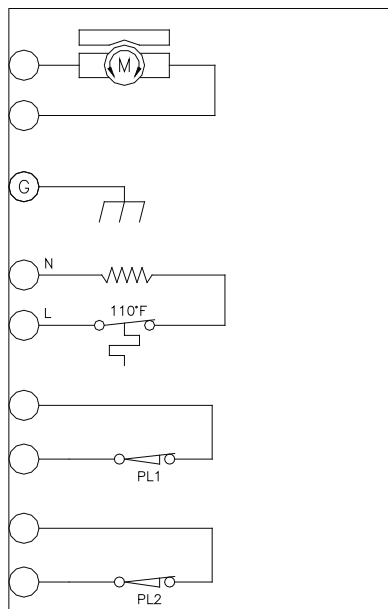

# Wiring Diagram

SM-1630-D & SM-1650-D

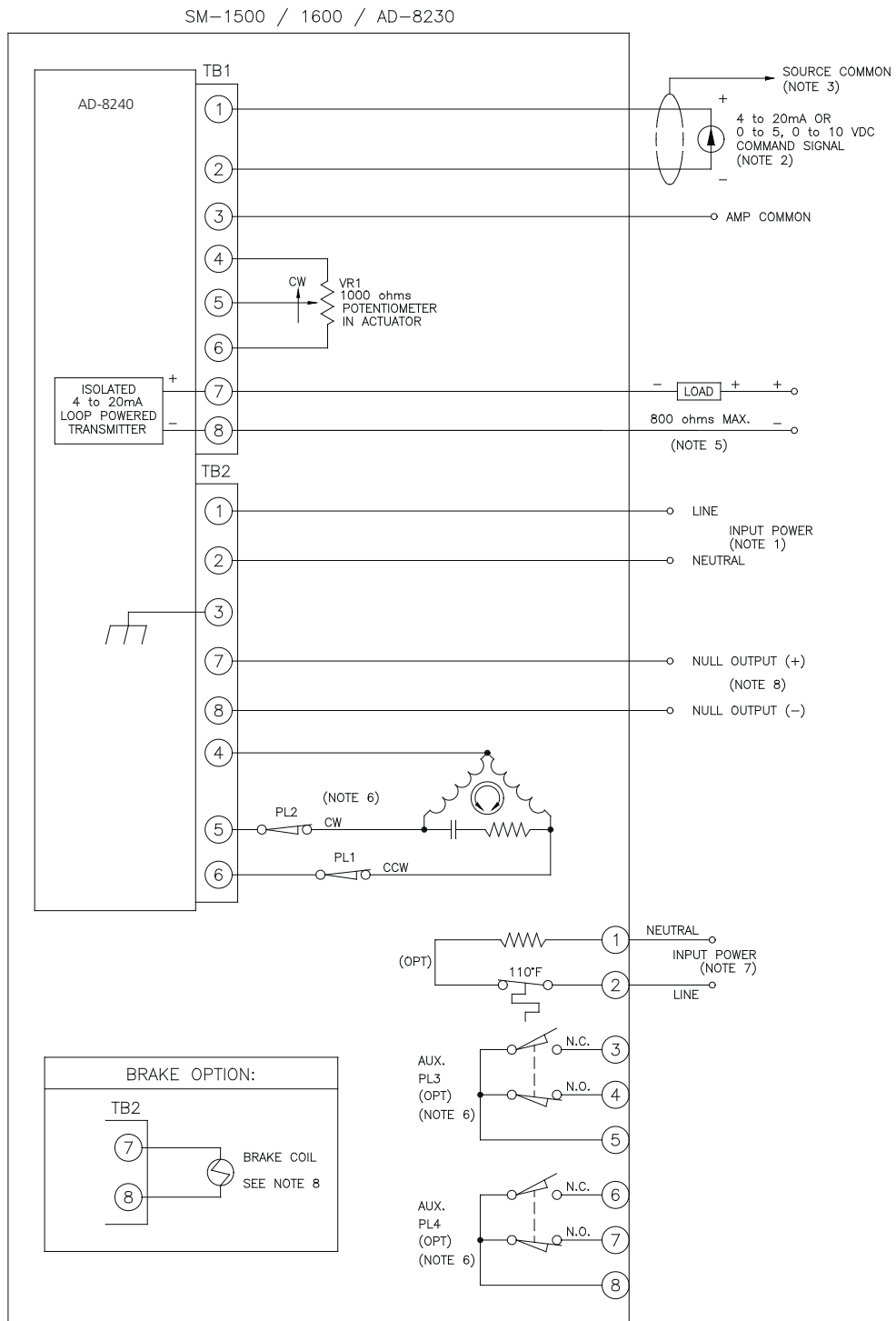

Note: Unit is not watertight until after unit and conduit connections are sealed by customer after wiring.

# Amplifier Specifications

## AD-8240 for SM-1630-D & SM-1650-D

- **Standard Line Voltage:** 120/240 VAC,  $\pm 10\%$ , 50/60 Hz (Slide switch select)  
(Voltage input MUST match the actuator motor voltage rating).
- **Power Consumption:** Less than 20 Watts for amplifier functions only.
- **Voltage Output:** Identical to voltage input.
- **Current Output:** 10 Amps max. at 120 or 240 VAC.
- **Fuse protection:** Customer supplied.  
Size based on actuator controlled and local codes.
- **Null output (AD-8240):** Rated 2 amperes @120/240 VAC, 50/60Hz.
- **Command Signal Inputs:**
  - 4-20 mA, 4-12 mA, 12-20 mA into a 200  $\Omega$  shunt resistor
  - 0-5 VDC into 100,000  $\Omega$  impedance
  - 0-10 VDC into 100,000  $\Omega$  impedance
- **Position Feedback Signal:** 1000  $\Omega$  potentiometer 4-20 mA (optional)
- **Position Output Signal:** Isolated 4-20 mA, loop powered with 12-36 VDC external power supply.
- **Field Wiring Terminations:** Pluggable terminal block, wire size range 26-14 AWG.
- **Command Signal Monitor:**  
The 8000 series loss-of-signal circuitry monitors the command signal input. If the command signal drops below or above the rating, the actuator will either lock in place or run to a preset position (user selectable).
- **Limit Signals:** *Internal:* Part of servo control.
- **Output Shaft Motion:**  
All models can go either direction on an increasing command signal. This is determined by the ZERO and SPAN settings.
- **Temperature Limits:**  
-40 to 150 °F (-40 to 65 °C).
- **Duty Cycle:** Unrestricted modulating duty. (Cont. duty).
- **Position Accuracy:** 1% of full travel
- **Repeatability:** 0.5% of full travel
- **Hysteresis:** 0.5% of full travel
- **Linearity:** +/- 1% of full travel
- **Deadband:** 0.75% of full travel
- **Resolution:** 0.75% of full travel

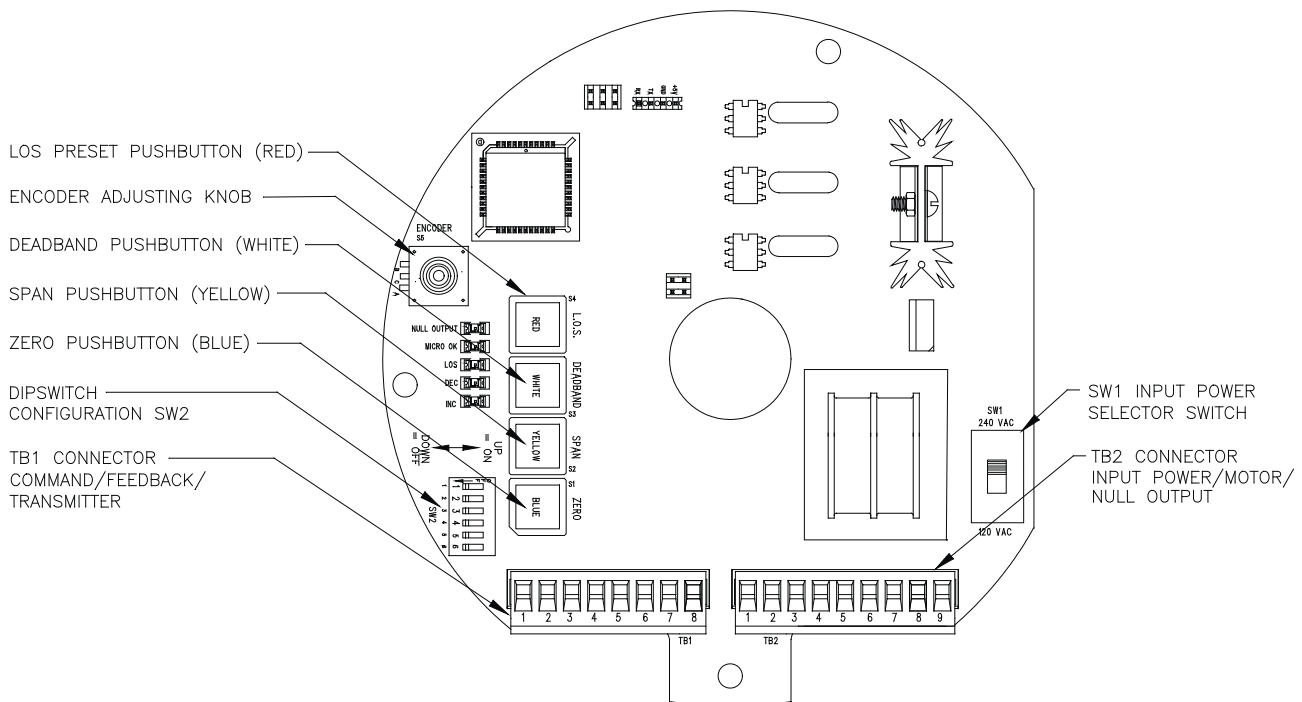

# Actuator Start-up

## SM-1630-D & SM-1650-D

The ACTUATOR/AMPLIFIER combination has been factory calibrated and only minor adjustments will need to be made during installation.

- 1) **Power.** Ensure the slide switch is set to the correct voltage (120/240 VAC) before applying AC power to TB2.
- 2) **Command Calibration.** This procedure calibrates the minimum and maximum command to the unit.
  - A) Set command signal to low level, normally 4 mA.
  - B) Depress ZERO pushbutton (S1) and LOS pushbutton (S4) until the LOS LED flashes.
  - C) Set command signal to high level, normally 20 mA.
  - D) Depress SPAN pushbutton (S2) and LOS pushbutton (S4) until the LOS LED flashes.
- 3) **Auto/Manual (Option).** If the actuator has the Auto/Manual switch option, place it in the auto position.
- 4) **Setpoints.** These are the end of travel extremes corresponding to the actuator output shaft positions for low (4 mA) and high (20 mA) command signal levels. They are set by the ZERO and SPAN pushbuttons and adjusting knob. All settings require the holding down of a push button and the turning of the adjusting knob.
  - A) Set the command signal to lowest level, normally 4 mA.
  - B) Adjust LO setpoint (ZERO) by holding ZERO push button (S1) and turning adjusting knob to move actuator output shaft to desired position. Turn the adjusting knob clockwise (CW) to rotate the output shaft CW. Turn the adjusting knob counter-clockwise (CCW) to rotate the output shaft CCW. Release button.
  - C) Set the command signal to highest level, normally 20 mA.
  - D) Adjust HI setpoint (SPAN) by holding SPAN push button (S2) and turning adjusting knob to move actuator output shaft to desired position. Turn the adjusting knob CW to rotate the output shaft CW. Turn the adjusting knob CCW to rotate the output shaft CCW. Release button.
- 5) **Transmitter.** This adjustment sets the endpoints of the 4-20 mA transmitter to account for variations in accuracy of the input command.
  - A) Set command signal to low level, normally 4 mA.
  - B) Depress ZERO pushbutton (S1) and LOS pushbutton (S4) until the LOS LED flashes. While depressing pushbuttons, turn adjusting knob CW to increase the 4 mA point, or CCW to decrease the 4 mA point.
  - C) Set command signal to high level, normally 20 mA.
  - D) Depress SPAN pushbutton (S2) and LOS pushbutton (S4) until the LOS LED flashes. While depressing pushbuttons, turn adjusting knob CW to increase the 20 mA point, or CCW to decrease the 20 mA point.
- 6) **Deadband.** This adjustment establishes the actuator servo sensitivity. It is factory set at 1% and should not need to be field adjusted. If the actuator begins to oscillate (Green and Yellow LEDs turn on and off rapidly), decrease the sensitivity by holding deadband push button (S3) and turning adjusting knob CW until oscillation stops. Release button.
- 7) **Loss of Signal Preset.** This adjustment establishes the position to which the actuator will travel upon a loss of command signal condition. To activate this setting, SW3 must be OFF. Adjust the setting by holding the LOS push button (S4) and turning the adjusting knob to set the preset position. Turn the adjusting knob CW to extend the output shaft for linear actuators, or rotate the output shaft CW for rotary actuators. Turn the adjusting knob CCW to retract the output shaft for linear actuators, or rotate the output shaft CCW for rotary actuators.
- 8) **Verify all settings** by running the actuator through its travel range several times.

# Amplifier Specifications

## AD-8260 for SM-1680-D

- **Standard Line Voltage:** 24 VDC,  $\pm 10\%$
- **Power Consumption:** Varies depending on actuator.
- **Fuse protection:** Customer supplied. Size based on actuator controlled and local codes.
- **Command Signal Inputs:**
  - 4-20 mA, 4-12 mA, 12-20 mA into a 200 $\Omega$  shunt resistor
  - 0-5 VDC into 100,000 $\Omega$  impedance • 0-10 VDC into 100,000 $\Omega$  impedance
- **Position Feedback Signal:** 1000 $\Omega$  potentiometer 4-20 mA
- **Position Output Signal:** Isolated 4-20 mA, loop powered with 12-36 VDC external power supply.
- **Field Wiring Terminations:** Plugable terminal block, wire size range 26-14 AWG.
- **Command Signal Monitor:** The 8000 series loss-of-signal circuitry monitors the command signal input. If the command signal drops below or above the rating, the actuator will either lock in place or run to a preset position (user selectable).
- **Limit Signals:** Internal: Part of servo control.
- **Output Shaft Motion:** All models can go either direction on an increasing command signal. This is determined by the ZERO and SPAN settings.
- **Temperature Limits:** -40 to 150 ° F (-40 to 65 ° C).
- **Duty Cycle:** Unrestricted modulating duty. (Cont. duty).
- **Position Accuracy:** 1% of full range.
- **Deadband:** Factory preset to 1%. Field adjustable.

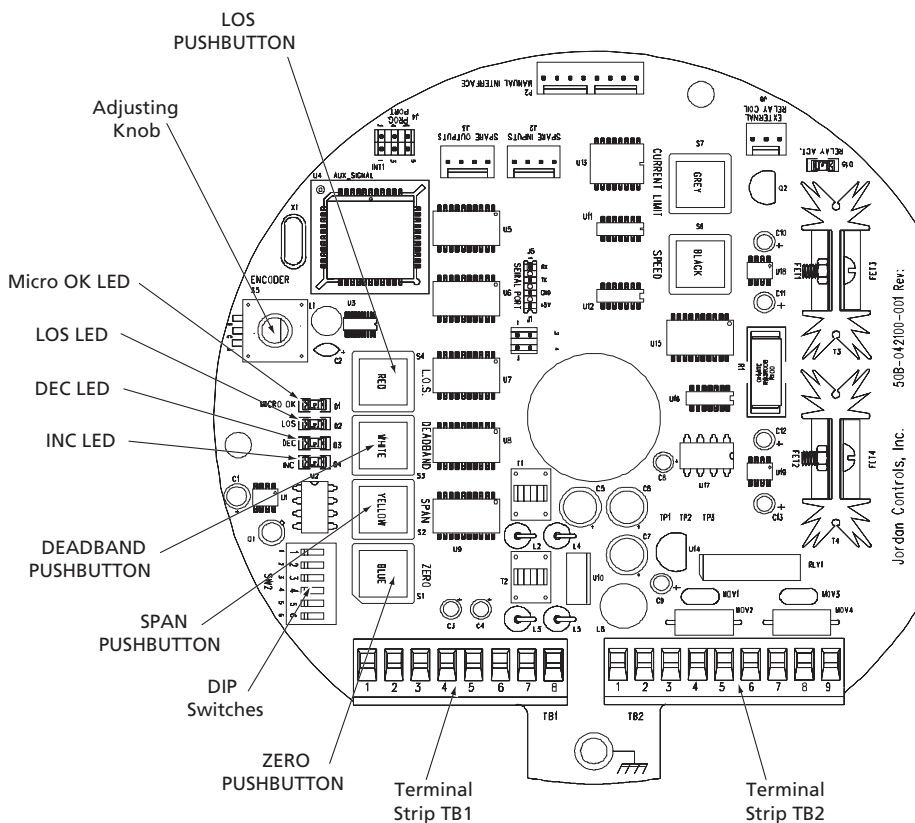

# Actuator Start-Up

## SM-1680-D

For component identification, refer to illustration on last page of manual.

- 1) Power.** Verify +24 VDC power connection to TB2- 1 and TB2-2.
- 2) Initial Speed Calibration.** This procedure is used to make sure that the current limit and speed are set to a high enough level for the operation of the unit. If the unit has been setup previously, then this step can be omitted.
  - A) Depress the speed pushbutton (black) while turning the adjusting knob CW approximately 3 turns.
  - B) Depress the current limit pushbutton (white) while turning the adjusting knob CW approximately 3 turns.
- 3) Auto/Manual (Option).** This procedure calibrates the minimum and maximum command to the unit.
  - A) Set command signal to low level, normally 4 mA
  - B) Depress Zero pushbutton (blue) and LOS pushbutton (red) until the LOS LED flashes.
  - C) Set command signal to high level, normally 20 mA
  - D) Depress Span pushbutton (yellow) and LOS pushbutton (red) until the LOS LED flashes.
- 4) Setpoints.** These are the end of travel extremes corresponding to the actuator output shaft positions for low (4 mA) and high (20 mA) command signal levels. They are set by the ZERO and SPAN pushbuttons and adjusting knob. All settings require the holding of a push button and the turning of the adjusting knob. Note: Most of the actuators have end of travel limit switches. Be sure that these are not being tripped to limit the travel during the setpoint adjustment.
  - A) Set the command signal to lowest level, normally 4 mA.
  - B) Adjust LO setpoint (ZERO) by holding ZERO push button (S1) and turning adjusting knob to move output shaft to desired position. Turn the adjusting knob CW to extend the output shaft for linear actuators, or rotate the output shaft CW for rotary actuators. Turn the adjusting knob CCW to retract the output shaft for linear actuators, or rotate the output shaft CCW for rotary actuators. Release button.
  - C) Set the command signal to highest level, normally 20 mA.
  - D) Adjust HI setpoint (SPAN) by holding SPAN push button (S2) and turning adjusting knob to move output shaft to desired position. Turn the adjusting knob CW to extend the output shaft for linear actuators, or rotate the output shaft CW for rotary actuators. Turn the adjusting knob CCW to retract the output shaft for linear actuators, or rotate the output shaft CCW for rotary actuators. Release button.
- 5) Transmitter.** This adjustment sets the endpoint of the 4-20 mA transmitter to account for variations in the accuracy of the input command.
  - A) Set the command signal to low level, normally 4 mA.
  - B) Allow the actuator to move to the set low level position
  - C) Press the ZERO pushbutton (blue) and the LOS pushbutton (red) until the LOS LED flashes. While depressed, turn the adjusting knob CW to increase the 4 mA transmitter output, or CCW to decrease the 4 mA transmitter output.
  - D) Set the command signal to high level, normally 20 mA.
  - E) Allow the actuator to move to the set high level position.
  - F) Press the SPAN pushbutton (yellow) and the LOS pushbutton (red) until the LOS LED flashes. While keeping these pushbuttons depressed, turn the adjusting knob CW to increase the 20 mA transmitter output, or CCW to decrease the 20 mA transmitter output.
- 6) Deadband.** This adjustment establishes the actuator servo sensitivity. It is factory set at 1% and should not be field adjusted. If the actuator begins to oscillate (Green and Yellow LEDs turn on and off rapidly), decrease the sensitivity by holding deadband push button (S3) and turning adjusting knob CW until oscillation stops. Release button.
- 7) Loss of Signal Preset.** This adjustment establishes the position to which the actuator will travel upon a loss of command signal condition. To activate this setting, SW3 must be OFF. Adjust the setting by holding the LOS push button (S4) and turning the adjusting knob to set the preset position. Turn the adjusting knob CW to extend the output shaft for linear actuators, or rotate the output shaft CW for rotary actuators. Turn the adjusting knob CCW to retract the output shaft for linear actuators, or rotate the output shaft CCW for rotary actuators.
- 8) Speed Setting.** This adjustment is used to change the speed of the actuator. To adjust the speed of the actuator, command the actuator to a position (so that the actuator is in motion). The speed can be increased by depressing the speed pushbutton (black) and turning the adjustment knob CW. The speed can be decreased by depressing the speed pushbutton (black) and turning the adjustment knob CCW. Note: If the current limit is set too low, the maximum speed of the unit will be affected. Prior to changing the speed, the current limit may need to be adjusted to its maximum value (see step 2).
- 9) Current Limit Setting.** If necessary, this setting can be used to limit the torque/thrust of the actuator. The current limit can be increased by depressing the current limit pushbutton (white) and turning the adjustment knob CW. The current limit can be reduced by depressing the current limit pushbutton (white) and turning the adjustment knob CCW.
- 10) Verify all settings** by running the actuator through its travel range several times.



# Actuator Start-Up

## SM-1630-N, SM-1650-N & SM-1680-N

NOTE: Unless specified by the customer at time of order, the keyway on the actuator output shaft has no specific orientation to the actuator mounting face.

The actuator has been factory calibrated for the range specified by the customer and only minor adjustments should be needed to match it to the controlled equipment.

### Final Alignment Consists of:

- A) Setting the end of travel limit switches for the range of the driven unit without running the actuator into a mechanical stop.
- B) Aligning the feedback potentiometer (pot) to the range of the actuator set by the end of travel limit switches.
- C) Calibrating the 4-20 mA transmitter (if supplied).

### ACTUATOR ALIGNMENT FOR AC UNITS

- 1) If the actuator has been mounted and coupled to the controlled equipment, remove the coupling between the actuator shaft and the driven unit.
- 2) Remove the actuator cover to gain access to the limit switches, feedback pot and terminals.
- 3) Determine which direction of rotation (CW or CCW) is to be the ZERO end of travel on the driven shaft and on the actuator output shaft. This will be the starting point for alignment.
- 4) Apply power across terminals 1 and 2 to drive the actuator output shaft "CCW"; or to terminals 1 and 3 to drive the shaft "CW" (looking at the shaft from the mounting face side). Select the appropriate terminals to drive the shaft to the "ZERO" position as it relates to the driven shaft being controlled.
- 5) With both shafts at the "ZERO" starting position, couple the shafts together. If the keyway on the actuator output shaft must be rotated, apply power to the actuator to move the shaft in the increase direction until the keyway is located where you want it.
- 6) At this position it is necessary to set the "ZERO" limit switch to just "trip" before a mechanical stop (if the driven unit has one) is reached.

If only a small amount of adjustment is needed, loosen the 3 truss head screws and rotate the limit switch assembly just until the switch trips. Tighten the 3 screws.

If a large amount of adjustment is needed, remove the 3 screws, lift the switch assembly off of the mounting plate, turn the switch shaft until the switch just trips, re-insert the frame into the mounting plate and install the 3 screws.

- 7) If the actuator is equipped with a feedback pot, measure the resistance from terminal 5 to terminal 4 or 6 (whichever is the ZERO end). Loosen the pot body nut and rotate the body of the pot for a resistance reading of 5% of the total pot value. Rotating the pot too far may cause the pot terminals to hit the cover or motor. If this is the case refer to step 6 and re-adjust the switch shaft and end of travel switch.
- 8) Monitor the feedback pot from terminal 5 to the terminal which represents the increase end. Apply power to drive the actuator to the desired maximum rotation position. Do not allow the actuator to drive into a mechanical stop and do not drive the pot to less than 5% of its value at the actuator end of travel. Travel to the ends of a pot will break a ten turn pot or cause the signal to be lost on a one turn pot.
- 9) If the actuator is supplied with a 4-20 mA transmitter, refer to the appropriate wiring diagram (supplied with the actuator) for transmitter calibration.
- 10) When alignment is complete or when work on the actuator is halted, install the actuator cover to protect the internal components.

### ACTUATOR ALIGNMENT FOR DC UNITS

The alignment of a DC actuator is similar to that of the AC actuator with a few exceptions.

- 1) The input power is applied across terminals 1 and 2. The polarity of the input power determines the actuator output shaft direction of rotation.
- 2) The end of travel position limit switches are not wired in series with the motor and must be field wired to your motor control circuit and phased properly to turn off motor power when the proper switch is "tripped".
- 3) If the actuator is supplied with a motor brake, power must be supplied from an external source to the motor brake terminals. When motor power is applied, brake power must also be applied.
- 4) The terminal numbers for the components in the DC actuator are different than the terminal numbers in the AC actuator.
- 5) The operation and phase control of the limit switch circuit should be checked with the actuator near its center of travel, to prevent damage of the controlled unit or the actuator. Improper phasing will cause the actuator motor to receive power and run when the switch is supposed to stop it.



# Actuator Troubleshooting guide

SM-1630-N, SM-1650-N & SM-1680-N

Trouble	Possible Cause	Remedy
Motor does not operate.	<ul style="list-style-type: none"> <li>a. No power to actuator.</li> <li>b. Motor overheated and internal thermal switch tripped (single-phase AC motors only).</li> <li>c. Motor burned out.</li> <li>d. Motor drag brake not releasing.</li> <li>e. Motor drag brake defective.</li> <li>f. Actuator output shaft stalled.</li> <li>g. Manual handcrank engaged, or handcrank switch M.C.L.S. is open.</li> <li>h. Defective motor run capacitor.</li> </ul>	<ul style="list-style-type: none"> <li>a. Check source, fuses, wiring.</li> <li>b. Let motor cool and determine why overheating occurred (such as, excessive duty cycle or ambient temperature).</li> <li>c. Replace motor and determine cause of failure.</li> <li>d. Check brake and brake circuit.</li> <li>e. Replace drag brake.</li> <li>f. Check drive load for mechanical jam and correct cause.</li> <li>g. Disengage handcrank to close switch.</li> <li>h. Replace capacitor (AC models).</li> </ul>
Motor hums but does not run.	<ul style="list-style-type: none"> <li>a. Actuator output shaft stalled.</li> <li>b. Power applied to both directions of rotation at the same time.</li> <li>c. Jammed, damaged power gearing.</li> <li>d. Motor brake not releasing.</li> <li>e. Defective motor run capacitor.</li> <li>f. Does not know the words.</li> </ul>	<ul style="list-style-type: none"> <li>a. Check load on output shaft.</li> <li>b. Apply power to only one direction of rotation at a time.</li> <li>c. Repair gearing.</li> <li>d. Check brake and brake circuit.</li> <li>e. Replace capacitor.</li> <li>f. Teach it the words.</li> </ul>
Motor runs only one way.	<ul style="list-style-type: none"> <li>a. Power not applied for other direction.</li> <li>b. Power always applied to one direction and electrically stalls when applied for opposite direction.</li> <li>c. Open limit switch for other direction.</li> <li>d. Open motor winding.</li> </ul>	<ul style="list-style-type: none"> <li>a. Correct power problem.</li> <li>b. Correct power problem.</li> <li>c. Reset switch adjustment or replace.</li> <li>d. Replace motor.</li> </ul>
Motor runs, but output shaft does not rotate.	<ul style="list-style-type: none"> <li>a. Broken or worn power gearing.</li> </ul>	<ul style="list-style-type: none"> <li>a. Repair power gearing.</li> </ul>
Motor does not shut off at limit switch.	<ul style="list-style-type: none"> <li>a. Switch wired wrong or is defective.</li> <li>b. Actuator is coasting through switch cam dwell area and switch is resetting.</li> </ul>	<ul style="list-style-type: none"> <li>a. Correct wiring or replace switch.</li> <li>b. Change power gearing to slower speed. Add motor brake and brake circuit.</li> </ul>
Motor brake does not hold motor shaft.	<ul style="list-style-type: none"> <li>a. Brake disc is worn.</li> <li>b. Set screws in brake hub are loose.</li> </ul>	<ul style="list-style-type: none"> <li>a. Adjust brake air gap.</li> <li>b. Remove brake and tighten set screws.</li> </ul>
Motor brake does not release.	<ul style="list-style-type: none"> <li>a. Defective brake control circuit.</li> <li>b. No brake air gap.</li> <li>c. Defective brake coil.</li> </ul>	<ul style="list-style-type: none"> <li>a. Replace control circuit.</li> <li>b. Adjust air gap.</li> <li>c. Replace entire brake.</li> </ul>
Pot feedback signal not present at some position of actuator output shaft.	<ul style="list-style-type: none"> <li>a. Pot not aligned with end of travel switches and is being driven through dead region.</li> <li>b. Pot signal is erratic or pot broken.</li> </ul>	<ul style="list-style-type: none"> <li>a. Align pot to range of actuator.</li> <li>b. Replace pot.</li> </ul>
Pot signal does not change as output shaft turns.	<ul style="list-style-type: none"> <li>a. Broken or burnt-out pot.</li> <li>b. Feedback gear not turning pot shafts.</li> </ul>	<ul style="list-style-type: none"> <li>a. Replace pot.</li> <li>b. Check gearing engagement and set screws in gear hubs.</li> </ul>
Pot signal is reversed for output shaft rotation.	<ul style="list-style-type: none"> <li>a. Pot is wired wrong to terminals.</li> </ul>	<ul style="list-style-type: none"> <li>a. Reverse wiring from ends of pot at actuator terminal block.</li> </ul>
Output shaft rotates wrong direction for CW and CCW input power.	<ul style="list-style-type: none"> <li>a. Incorrect wiring to actuator.</li> <li>b. Wiring from motor to terminals or switches is backward.</li> </ul>	<ul style="list-style-type: none"> <li>a. Correct field wiring.</li> <li>b. Correct internal actuator wiring.</li> </ul>
Water droplets inside motor area of actuator.	<ul style="list-style-type: none"> <li>a. Condensation caused by temperature variations and humidity.</li> <li>b. Water entering actuator.</li> </ul>	<ul style="list-style-type: none"> <li>a. Add heater and thermostat circuit or keep existing circuit energized.</li> <li>b. Keep cover screwed down tight, make sure conduit entry is sealed.</li> </ul>



# Amplifier Troubleshooting

For visual troubleshooting, LEDs are provided to display the status of the actuator. These are located on the same side of the lower board as SW1. The identification of these LEDs are shown in the table below, and are ordered as the LEDs appear: left to right.

Refer to page 17 for information on actuator troubleshooting.

## Amplifier Troubleshooting for AD-8240

LED	Function
MICRO OK	This LED flashes when the microprocessor is running. If this is not on, verify power to the board.
INC	This LED is on when the actuator is extending the output shaft for linear actuators, or rotating the output shaft CW for rotary actuators.
DEC	This LED is on when the actuator is retracting the output shaft for linear actuators, or rotating the output shaft CCW for rotary actuators.
L.O.S.	1 Flash - Indicates loss of 4-20 mA signal (LOS). 2 Flashes - Indicates loss of the feedback signal. 3 Flashes - Indicates a stall condition.

## Amplifier Troubleshooting for AD-8260

LED	Function
Microprocessor running (D4)	This LED flashes when the microprocessor is running. If this is not on, verify power to the board.
Actuator Increasing	This LED is on when the actuator is rotating the output shaft clockwise (CW).
Actuator Decreasing	This LED is on when the actuator is rotating the output shaft counter-clockwise (CCW).
Fault	This LED will illuminate if there is a loss of 4-20 mA signal (LOS).

# Installation Dimensions

SM-1600	A		B		C		D
	Without an internal amplifier	With an internal amplifier	Without an internal amplifier	With an internal amplifier	Handcrank without an internal amplifier	Handcrank with an internal amplifier	
Nema Type 4 Watertight and X-proof	7.00 (177.8)	10.13 (257.3)	12.20 (309.9)	15.33 (389.4)	15.76 (400.3)	18.89 (479.8)	3.20 (81.3)

Output Shaft Dimensions	SM-1600 Series
Output Shaft Diameter	0.9990-0.9996 (25.375/25.390)
Keyway Dimensions	0.250 W x 0.145 D x 1.25 L
Key (supplied)	1/4 Sq. x 1.19 L

## SM-1600 Major Dimensions

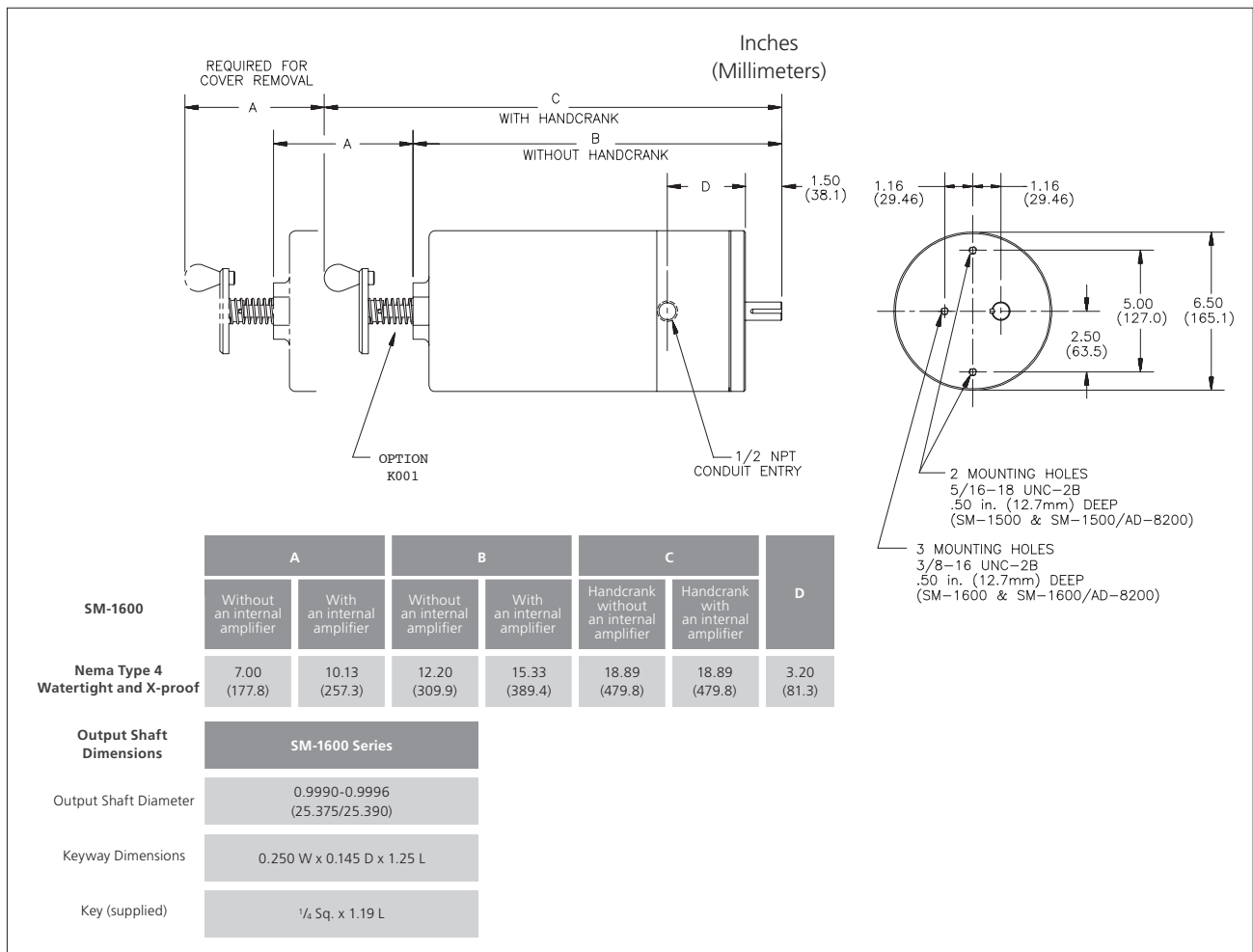

These dimensions are subject to change without notice and should not be used for preparation of drawings or fabrication of installation mounting. For current installation manuals and other product information, see [www.rotork.com](http://www.rotork.com).

## DIP Switch Charts

**NOTE:** When selecting a current command configuration, Jumper on J4 is between pins 3 and 4. When selecting a voltage command configuration, Jumper on J4 is between pins 5 and 6, prior to unit power-up.

DIP Switch Chart for AD-8240

Switch	Switch Position	Function
1	On (Up)	Current Command
	Off (Down)	0-5 V / 0-10 V Voltage Command
2	On (Up)	0-5 V Voltage Command
	Off (Down)	Current / 0-10 V Command
3	On (Up)	LOS Lock-In-Place
	Off (Down)	LOS Preset Position
4	On (Up)	Dynamic Brake On
	Off (Down)	Dynamic Brake OFF
5	On (Up)	Null Output is On When Motor is at Idle
	Off (Down)	Null Output is On When Motor is at RUNNING
6	On (Up)	4-20 mA Feedback (not transmitter output)
	Off (Down)	Voltage Feedback

DIP Switch Chart for AD-8260

Switch	Switch Position	Function
1	On (Up)	Current Command
	Off (Down)	0-5 V / 0-10 V Voltage Command
2	On (Up)	0-5 V Voltage Command
	Off (Down)	Current / 0-10 V Command
3	On (Up)	LOS Lock-In-Place
	Off (Down)	LOS Preset Position
4	On (Up)	SPARE
	Off (Down)	SPARE
5	On (Up)	SPARE
	Off (Down)	SPARE
6	On (Up)	Remote Feedback Enabled
	Off (Down)	Remote Feedback Disabled

# Parts Identification

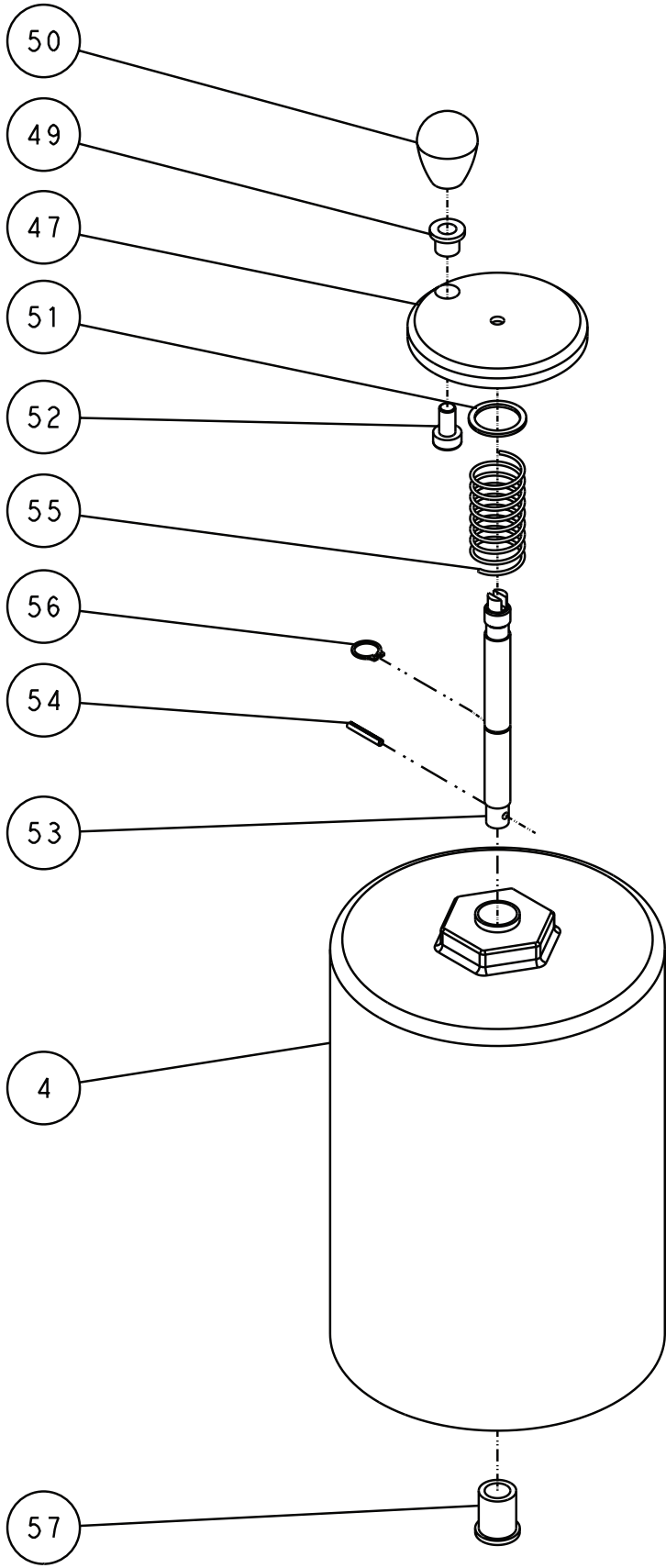

# Parts Identification

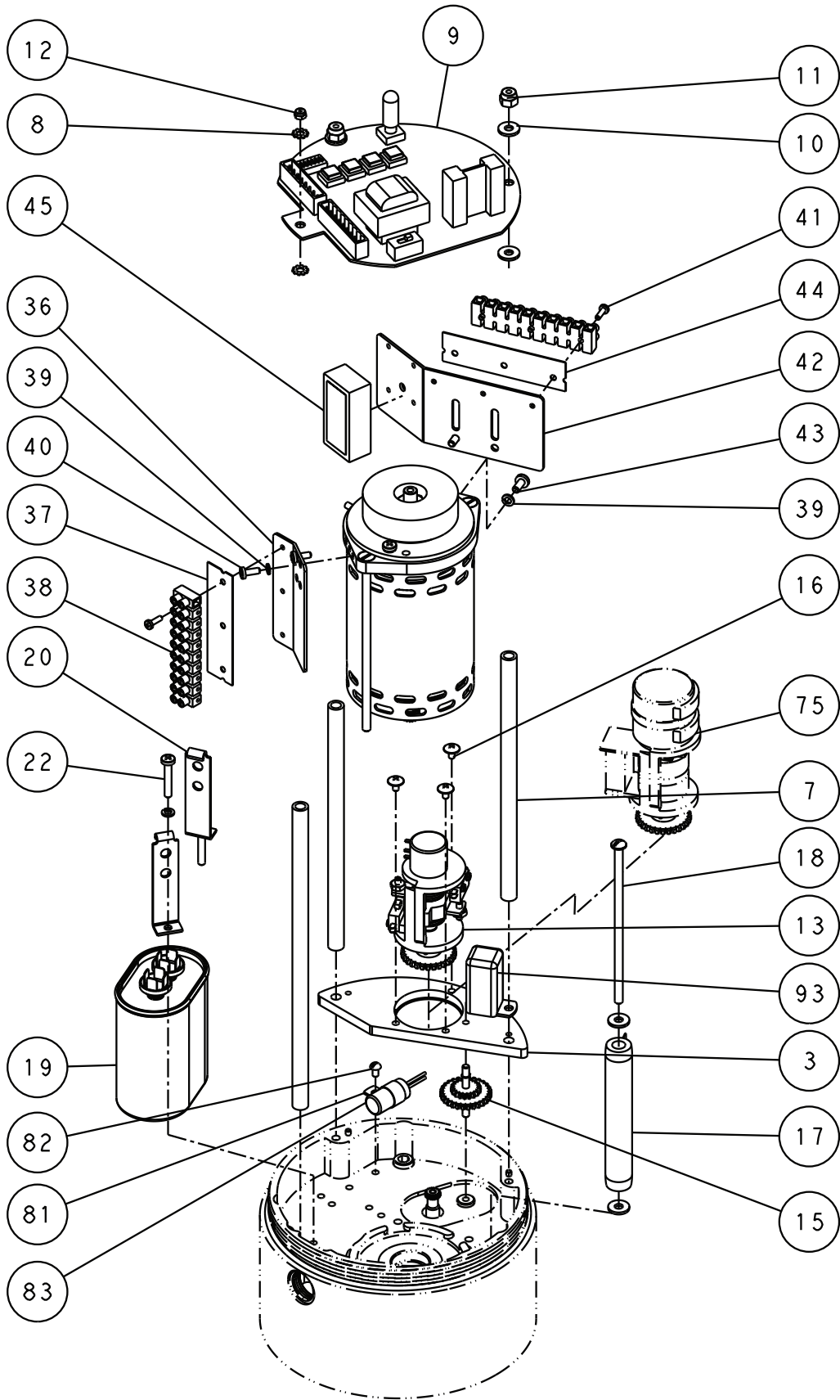

## Parts Identification

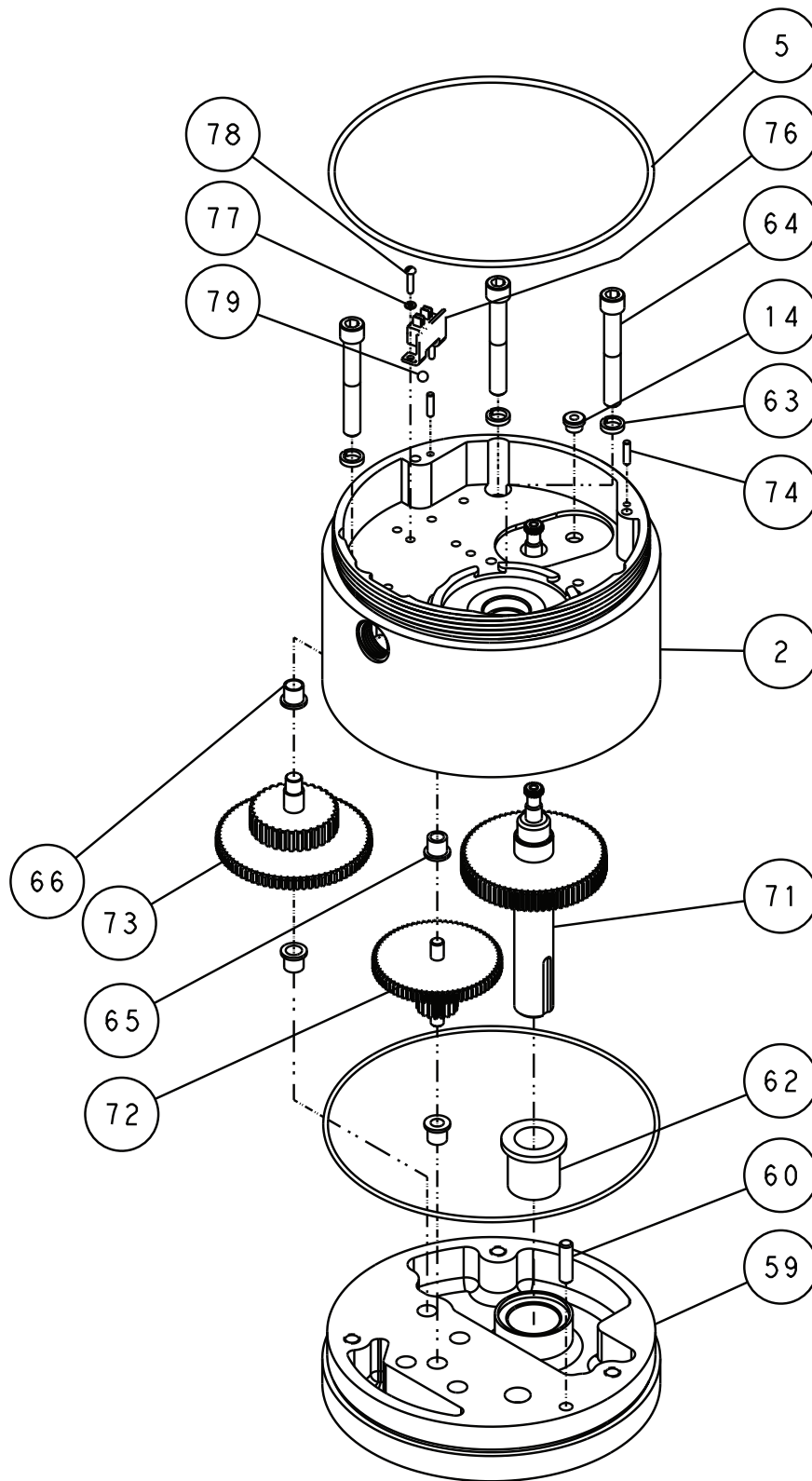

# Parts Identification

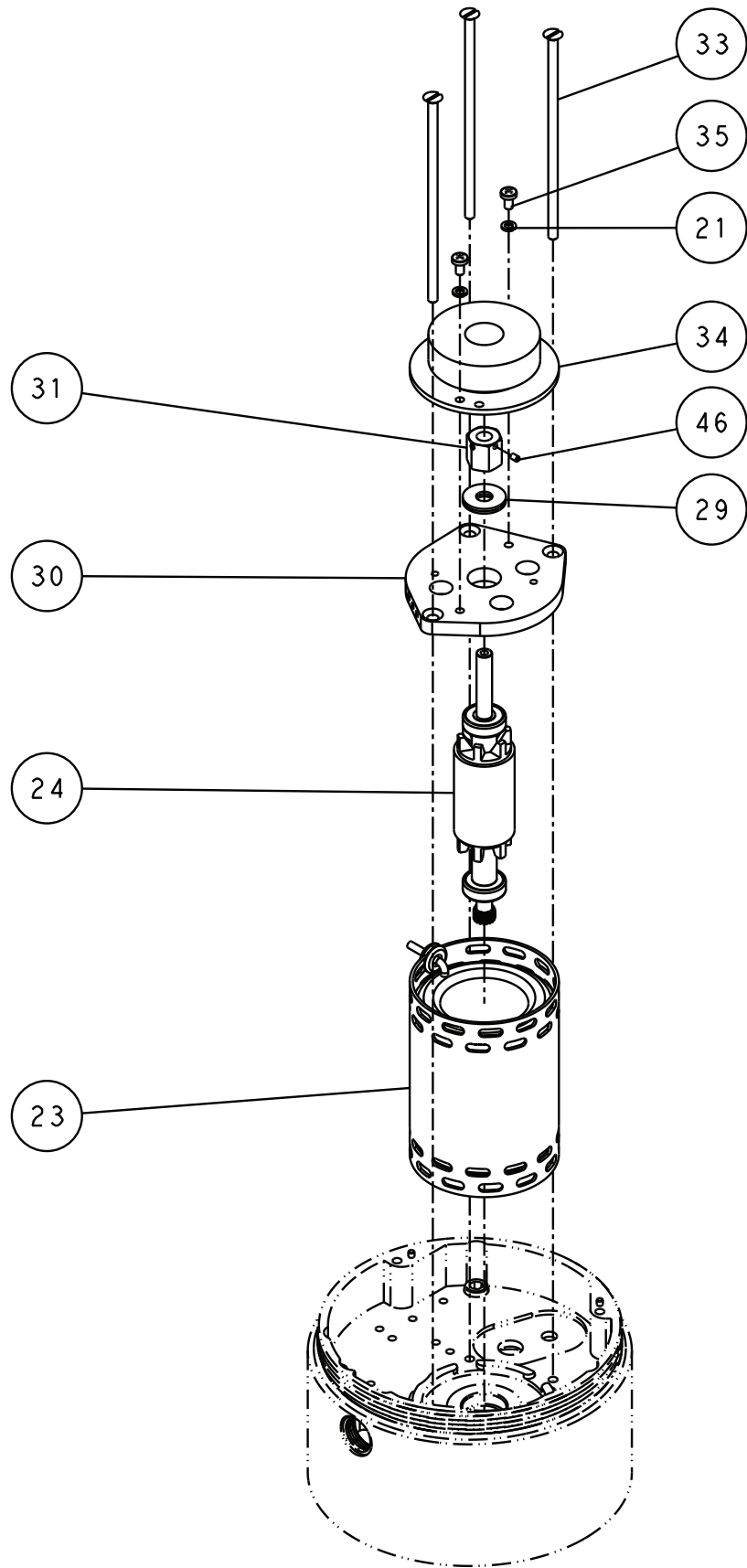



# Parts Identification

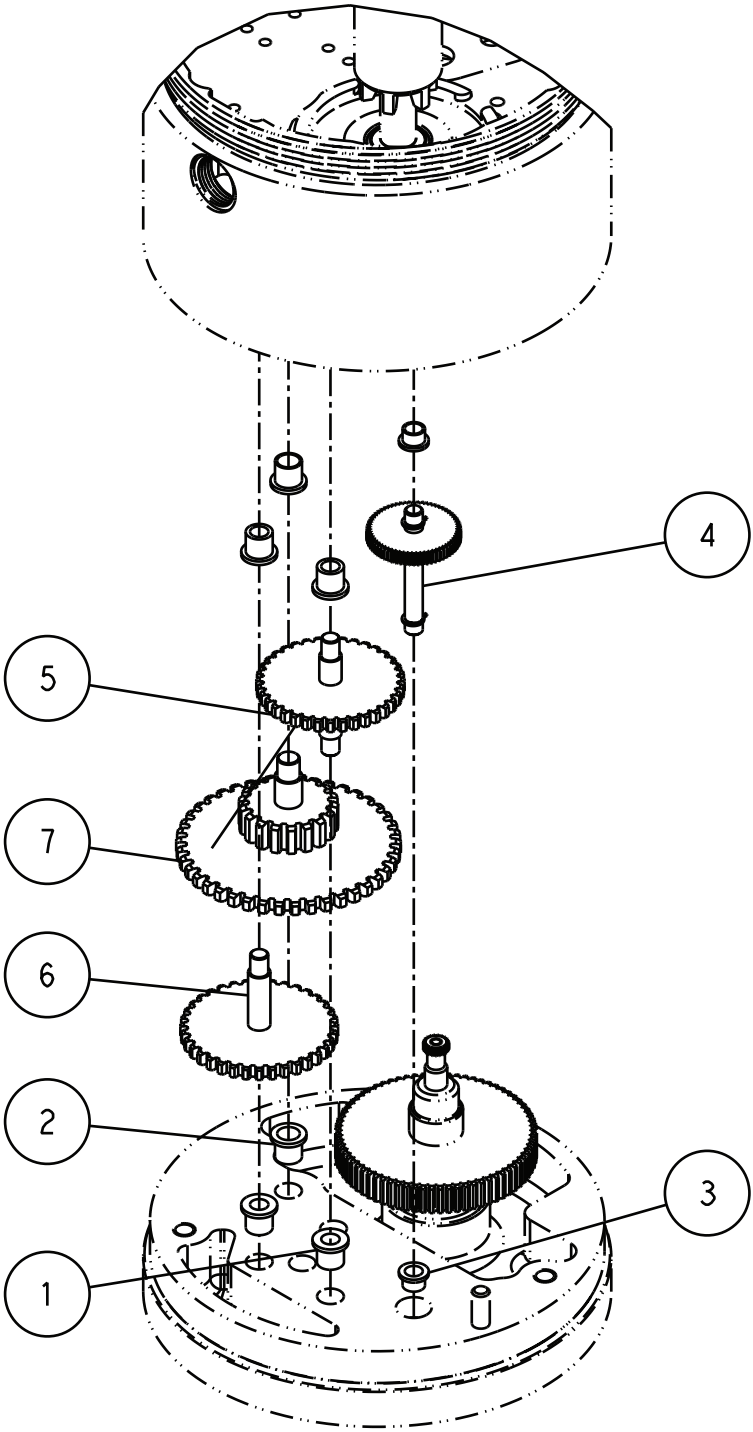

## Parts Identification

Item No.	Part	Description	Quantity
1	1600 ASM	1600 Actuator assembly	1
2	1600 GEAR HOUSING	Gear Housing	1
3	1600 LMSW BASE	Limit Switch Base	1
4	1600 MAIN COVER MACHINED	Main Cover	1
5	1600 ORING GEARHSG-COVER	O-Ring Gear Housing - Cover	1
6	1600 TUBE PCB SPACER GND	Spacer Tube	1
7	1600 TUBE PCB SPACER	Spacer Tube	2
8	EXLWSHR08	Generic Ext. Lock Washer	2
9	1600 AMPLIFIER DGTL	Digital Amplifier PCB Assembly	1
	1600 AMPLIFIER TB1	Terminal Block	1
	1600 AMPLIFIER TB2	Terminal Block	1
	1600 AMPLIFIER BUT SW	Switch	4
	1600 AMPLIFIER DIP SW	Switch	1
	1600 AMPLIFIER SLIDE SW	Switch	1
	1600 AMPLIFIER TOGGLE SW	Switch	1
	1600 AMPLIFIER HEATSINK	Heatsink	1
	1600 AMPLIFIER XFMR	Transformer	1
10	1600 WASHER FIBER PCB	Fiber Washer	6
11	ELHEXNUT10	Nut Hex #10-24 ESNA	2
12	ELHEXNUT08	Nut Hex #8-32 ESNA	1
13	1600 LIMIT SWITCH ASM	Limit Switch Assembly	1
	1600 LMSW BRKT	Bracket	1
	1600 LMSW MOTOR	Motor	1
	1600 LMSW MOTOR WASHER	Washer	1
	1600 LMSW MOTOR NUT	Generic Hex Jam Nut	1
	1600 LMSW SCREW SHAFT	Shaft	1
	SETSCRHXOVAL04 3	#4-40 Oval Point Screw	2
	1600 LMSW SCREW STOP	Stop Screw	1
	SETSCRHXOVAL06 6	#6-32 Oval Point Screw	2
	HXNUTREG 6	Hex Nut Reg #6-32 UNC	2
	1600 LMSW MICROSW	Micro-Switch	2
	LWINTERNAL 0086	Washer	4
	1600 LMSW MICROSCREW	Screw Micro-Switch Mnt	4
	1600 LMSW SCREW SHAFT 2	Shaft	1
	1600 LMSW MOTOR GEAR	Gear (21T, 32P)	1
	SETSCRHXOVAL04 1	#4-40 Oval Point Screw	2
14	1600 BUSHING IDLER ASM	Limit Switch Idler Assembly Bushing	1
15	1600 LMSW IDLER ASM	Limit Switch Idler Shaft Assembly	1
	1600 LMSW IDLER SHAFT	Shaft	1
	1600 LMSW IDLER CLIP	Limit Switch Idler Assembly Ext Clip	2
	1600 LMSW IDLER GEAR 1	Gear (21T, 32P)	1
	1600 LMSW IDLER GEAR 2	Gear (21T, 32P)	1
16	1600 LMSW SCREW 6-32X025	Screw Stove #6-32x.25	3
17	1600 RESISTOR	Resistor	1
18	1600 SCREW 10X450 SLOTTED	Screw Stove #10-32X4.50LG	1
19	1600 30UF CAPACITOR	30uF Capacitor	1
20	1600 CAPACITOR STRAP	Strap Capacitor Mount	2
21	LWSPLRNGREG 0164	Washer	6
22	PAN HD 008 1000	Generic Pan Head Screw	2
23	1600 MOTOR COIL	Motor Coil	1
24	1600 MOTOR CORE ASM	Motor winding core	1
25	1600 MOTOR SHAFT	Motor Shaft	1
26	1600 MOTOR BEARING	Motor Bearing	2
27	1600 MOTOR GEAR	Motor Gear	1
28	1600 MOTOR CORE	Motor Core	1
29	1600 MOTOR SPACER	Motor Shim	2
30	1600 MOTOR TOP	Top Plate	1
31	1600 MOTOR HEX	Motor Hex	1
32	1600 MOTOR GROMMET	Grommet Motor	1
33	1600 MOTOR FLATHD SCREW	SCR 100FLH #10-32X5.00LG	3
34	1600 MOTOR GENERATOR	Motor Generator	1
35	PAN HD 008 0312	Generic Pan Head Screw	2
36	1600 TERMBLK1 BRKT	Terminal Block 1 Bracket	1

## Parts Identification

Item No.	Part	Description	Quantity
37	1600 TERMBLK1 MARKER 1-10	Terminal Marker 1-10	1
38	1600 TERMINAL BLOCK	Terminal Block	2
39	LWSPLRNGREG 0138	Washer	2
40	PAN HD 006 0375	Generic Pan Head Screw	2
41	PAN HD 004 0375	Generic Pan Head Screw	6
42	1600 TERMBLK2 BRKT	Terminal Block 1 Bracket	1
43	PAN HD 008 0375	Generic Pan Head Screw	2
44	1600 TERMBLK1 MARKER 11-20	Terminal Marker 11-20	1
45	1600 VAPOR CAPSULE	Zerust Vapor Capsule	1
46	SETSCRHXOVAL04 1	#4-40 Oval Point Screw	2
47	1600 HANDLE	Top Handle Assembly	1
48	1600 HANDLE PLATE	Plate	1
49	1600 HANDLE BUSHING	Bushing	1
50	1600 KNOB	Knob	1
51	1600 HANDLE SPRING RING	Retainer	1
52	1600 HANDLE SCREW	Screw	1
53	1600 HANDLE SHAFT	Shaft	1
54	1600 HANDLE PIN	Pin	1
55	1600 HANDLE SPRING	Brake Spring	1
56	1600 HANDLE RETAINING RING	Retaining Ring	1
57	1600 COVER BUSHING	Bushing	1
58	1600 FRONT COVER	Cover Assembly	1
59	1600 FRONT COVER	Front Cover	1
60	1600 FRONT COVER PIN	Pin	1
61	1600 FRONT COVER ORING	O-Ring	1
62	1600 FRONT COVER MAIN BUSHING	Bushing	1
63	1600 FRONT COVER LCKWWSHR	Split Ring Lock Washer	3
64	1600 SCREW SKTHD 031 225	Socket Head Screw	3
65	1600 FRONT COVER BUSHING1	Bushing	12
66	1600 FRONT COVER BUSHING2	Bushing	6
67	1600 CRANK GASKET	Handcrank Gasket	1
68	1600 CRANK CASE	Handcrank Assembly	1
69	1600 LCKWWSHR 025	Split Ring Lock Washer	4
70	1600 SCREW SKTHD 025 075	Socket Head Screw	4
71	1600 MAIN SHAFT	Shaft Assembly	1
	1600 MAIN SHAFT	Shaft	1
	1600 MAIN SHAFT RETAINING RING	Retainer	1
	1600 MAIN GEAR	Gear	1
	1600 MAIN TINY GEAR	Gear	1
72	1600 GEAR STAGE2 -B 3-E	Gear Assembly	2
	1600 GEAR3 SHAFT	Shaft	1
	1600 GEAR3	Gear	1
	1600 GEAR3B	Gear	1
73	1600 GEAR STAGE3 E	Gear Assembly	1
	1600 GEAR2 SHAFT	Shaft	1
	1600 GEAR2	Gear	1
	1600 GEAR2B	Gear	1
74	1600 DWL PIN 012X050	Dowel Pin .12 dia. X .50 lg.	2
75	1600 LIMIT SWITCH ASM 2	Limit Switch Assembly	1
	1600 LMSW BRKT	Bracket	1
	1600 LMSW MOTOR	Motor	1
	1600 LMSW MOTOR WASHER	Washer	1
	1600 LMSW MOTOR NUT	Hex Jam Nut	1
	1600 LMSW SCREW SHAFT 2	Shaft	1
	1600 LMSW MOTOR GEAR	Gear	1
	SETSCRHXOVAL04 1	#4-40 Oval Point Screw	2
	1600 LIMIT SWITCH	Switch	1
76	1600 HANDLE LMSW	Side Handle Limit Switch	1
77	LWSPLRNGREG 0112	Washer	2
78	2837217		2
79	1600 HANDLE LMSW BALL	Side Handle Limit Switch Ball	1
80	1600 HANDLE SIDE SPACER	Side Handle Spacer	1
81	1600 HEATER CLIP	Heater Clip	1

## Parts Identification

Item No.	Part	Description	Quantity
82	2837325		1
83	1600 HEATER	Heater	1
84	1600 MAIN SHAFT STAGE 2	Stage 2 Main Shaft Assembly	1
	1600 MAIN SHAFT	Shaft	1
	1600 MAIN SHAFT RETAINING RING	Retainer	1
	1600 MAIN GEAR	Gear	1
	1600 MAIN TINY GEAR	Gear	1
85	1600 GEAR ASM STAGE 4 A	Gear Assembly	1
	1600 GEAR 3 SHAFT	Shaft	1
	1600 GEAR 3	Gear	1
	1600 GEAR 3 B	Gear	1
	1600 STAGE 4 A CLIP 025	External Clip	1
86	1600 GEAR STAGE 4 C	Gear Assembly	1
	1600 GEAR 2 SHAFT	Shaft	1
	1600 GEAR 2 B	Gear	1
	1600 GEAR 2	Gear	1
87	1600 GEAR STAGE 4 E	Gear Assembly	1
	1600 GEAR 2 SHAFT	Shaft	1
	1600 GEAR 2 B	Gear	1
	1600 GEAR 2	Gear	1
88	1600 FRONT BUSHING X	Bushing	2
89	1600 GEAR STAGE 5 X	Gear Assembly	1
	1600 GEAR STAGE 5 X	Gear	1
	1600 GEAR STAGE 5 X	Gear	1
	1600 GEAR 3 B STAGE 5 X	Gear	1
	1600 STAGE 4 A CLIP 025 STAGE 5 X	External Clip	2
90	1600 GEAR STAGE 5 A	Gear Assembly	1
	1600 GEAR 2 SHAFT STAGE 5 A	Shaft	1
	1600 GEAR 2 B STAGE 5 A	Gear	1
	1600 GEAR 2 STAGE 5 A	Gear	1
91	1600 GEAR STAGE 5 C	Gear Assembly	1
	1600 GEAR 2 SHAFT STAGE 5 C	Shaft	1
	1600 GEAR 2 B STAGE 5 C	Gear	1
	1600 GEAR 2 STAGE 5 C	Gear	1
92	1600 GEAR STAGE 5 E	Gear Assembly	1
	1600 GEAR 2 SHAFT STAGE 5 E	Shaft	1
	1600 GEAR 2 B SHAFT STAGE 5 E	Gear	1
	1600 GEAR 2 STAGE 5 E	Gear	1
93	1600 BLOCK	Block	1

Notes



## Notes



Notes



# rotork®

Electric Actuators and Control Systems  
Fluid Power Actuators and Control Systems  
Gearboxes and Gear Operators  
Projects, Services and Retrofit

## rotork® Process Controls

### UK

Rotork plc  
*tel* +44 (0)1225 733200  
*fax* +44 (0)1225 333467  
*email* mail@rotork.com

### USA

Rotork Process Controls  
*tel* +1 (414) 461 9200  
*fax* +1 (414) 461 1024  
*email* rpcinfo@rotork.com



A full listing of our worldwide sales and service network is available on our website.

## www.rotork.com