

rotork[®]
Controls

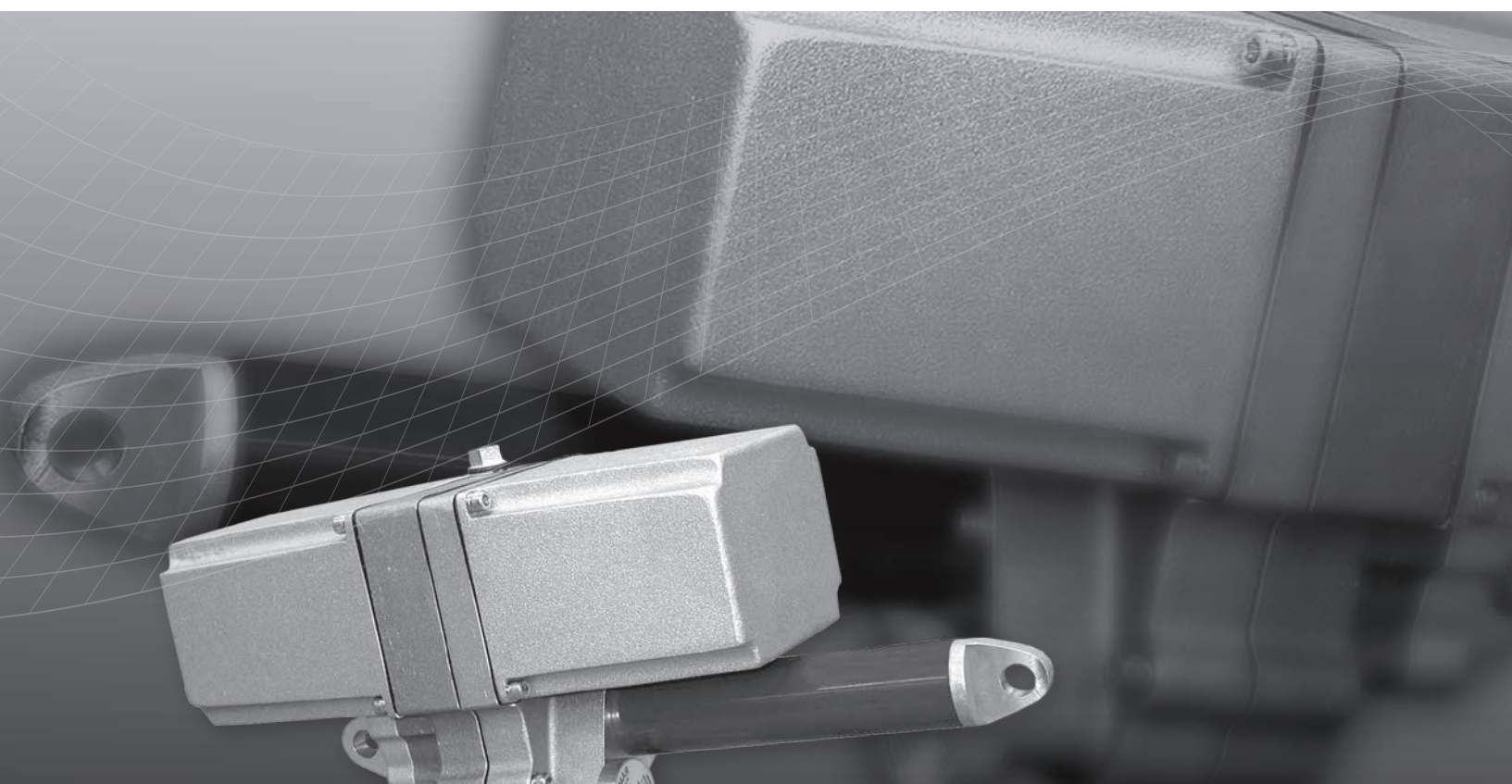

LA-2400 Series
Installation Manual



Linear Actuators

Redefining Flow Control

IM-0443

LA-2400 Series Linear Actuator

Table of Contents

General Information	3-4
Introduction	3
Receiving/Inspection	3
Storage	3
Equipment Return	3
Identification Label	4
Abbreviations Used in This Manual	4
General Actuator Description	4
Basic Models	4
Product Specifications	5
Installation	6
Typical Wiring Diagrams	7-8
Start-up/Calibration	9-10
Start-up/Calibration for Units with Amplifier....	11-14
Amplifier Specifications	11
Amplifier Start-up	12
Amplifier Parts Identification	13
Amplifier DIP Switch Chart	13
Typical Amplifier Wiring Diagram	14
Amplifier Troubleshooting Chart	14
Troubleshooting Guide	15-16
Component Location Drawing	17-18
Maintenance, Gear and Drive Nut Selection	19-20
Parts List and Recommended Spares	21-23
Major Dimensions	23-24

Due to wide variations in the terminal numbering of actuator products, actual wiring of this device should follow the print supplied with the unit.

GENERAL INFORMATION

INTRODUCTION

Rotork Controls, designs, manufactures, and tests its products to meet many national and international standards. For these products to operate within their normal specifications, they must be properly installed and maintained. The following instructions must be followed and integrated with your safety program when installing, using and maintaining Rotork Controls products:

- Read and save all instructions prior to installing, operating and servicing this product.
- If you do not understand any of the instructions, contact your Rotork Controls representative for clarification.
- Follow all warnings, cautions and instructions marked on, and supplied with, the product.
- Inform and educate personnel in the proper installation, operation and maintenance of the product.
- Install equipment as specified in Rotork Controls installation instructions and per applicable local and national codes. Connect all products to the proper electrical sources.
- To ensure proper performance, use qualified personnel to install, operate, update, tune and maintain the product.
- When replacement parts are required, ensure that the qualified service technician uses replacement parts specified by Rotork Controls. Substitutions may result in fire, electrical shock, other hazards, or improper equipment operation.
- Keep all product protective covers in place (except when installing, or when maintenance is being performed by qualified personnel), to prevent electrical shock, personal injury or damage to the actuator.

WARNING

Before installing the actuator, make sure that it is suitable for the intended application. If you are unsure of the suitability of this equipment for your installation, consult Rotork Controls prior to proceeding.

WARNING - SHOCK HAZARD

Installation and servicing must be performed only by qualified personnel.

WARNING - ELECTROSTATIC DISCHARGE

This electronic control is static-sensitive. To protect the internal components from damage, never touch the printed circuit cards without using electrostatic discharge (ESD) control procedures.

RECEIVING/INSPECTION

Carefully inspect for shipping damage. Damage to the shipping carton is usually a good indication that it has received rough handling. Report all damage immediately to the freight carrier and Rotork Controls. Unpack the product and information packet—taking care to save the shipping carton and any packing material should return be necessary. Verify that the items on the packing list or bill of lading agree with your own.

STORAGE

If the product will not be installed immediately, it should be stored in a clean, dry area where the ambient temperature is not less than -20° F. The actuator should be stored in a non-corrosive environment. The actuator is not sealed to NEMA 4 until the conduit entries are properly connected.

EQUIPMENT RETURN

A Returned Goods authorization (RG) number is required to return any equipment for repair. This must be obtained from Rotork Controls.

(Telephone: 414/461-9200) The equipment must be shipped, freight prepaid, to the following address after the RG number is issued:

Rotork Controls
5607 West Douglas Avenue
Milwaukee, Wisconsin 53218
Attn: Service Department

To facilitate quick return and handling of your equipment, include:

- RG Number on outside of box
- Company Name, Contact Person, Phone/Fax No.
- Address
- Repair Purchase Order Number
- Brief description of the problem

GENERAL INFORMATION

IDENTIFICATION LABEL

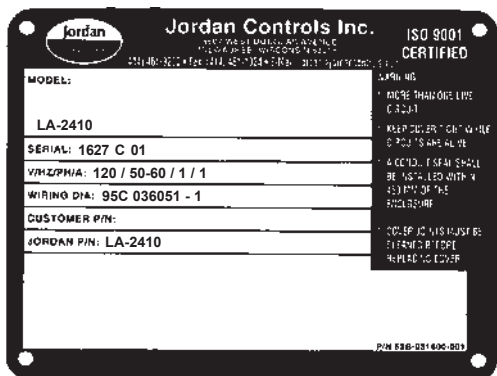

MODEL NUMBER: **LA24 10 Series**

SERIAL NUMBER: **1627 C 01**
 Sequential Number ——— Year Built
 ——— Month Built

GENERAL ACTUATOR DESCRIPTION

The LA-2400 series actuators are electrically operated, bi-directional linear devices. They are designed for strokes to 24 inches (610 mm) and thrusts to 1,500 lbf (6672 N) and include a non-clutchable manual override handwheel. The drive motor may be single or three phase ac, or dc.

Options Include:

- Up to four independently adjustable limit switches
- Contactless position feedback
- Linear potentiometer position feedback
- Thermostatically controlled anti-condensation heater
- Integral or remote servo-amplifiers
- Trunnion mounting
- 4 to 20mA position feedback
- Shaft bellows
- Paint/coatings

The LA-2400 series include 120/240 Vac single phase models, 240/380/480 Vac three phase models and 24 Vdc models. These actuators are controlled by “switched” power inputs or by a remotely installed servo-amplifier.

The LA-2400 series is also available with an internal servo-amplifier. They require 120 or 240 Vac (depending on model) unswitched, single phase line voltage input and a dc analog command signal for a complete, closed-loop positioning system in a compact enclosure.

ABBREVIATIONS USED IN THIS MANUAL

A or Amps	Ampere
AC	Alternating Current
° C	Degrees Celsius
CW	Clockwise
CCW	Counterclockwise
DC	Direct Current
° F	Degrees Fahrenheit
G	Earth Ground
Hz	Hertz
kg	Kilogram
L	Line (power supply)
lbs.	Pounds
lbf.	Lbs. Force
LVDT	Linear Variable Differential Transformer
mA	Milliamp
mfd	Microfarad
mm	Millimeters
N	Newton (force)
NEMA	National Electrical Manufacturing Association
Nm	Newton Meter
NPT	National Pipe Thread
Ph	Phase
PL	Position Limit Switch
RPM	Revolutions per Minute
sec.	Second
TL	Thrust Limit Switch
Vac	Volts ac
Vdc	Volts dc
VR	Variable Resistance
W	Watt

BASIC MODELS

LA-2410, LA-2420, LA-2450 and LA-2490 are all single phase ac, three wire, plug reversible models. They are compatible with Rotork Controls remotely located AD-8240 Series servo amplifiers, or any bi-directional contact type control.

These actuators may also be equipped with an internal servo amplifier that features loss of signal detection for current command signal inputs and can be calibrated to allow the actuator to lock-in-place or drive to a preset position should the command signal drop below 3.8mA. Also included is a dynamic brake circuit to increase positioning accuracy.

The LA-2415 is a three phase ac, plug reversible model compatible with Rotork Controls remotely located AD-8900 servo amplifier or any bi-directional contact type control. The LA-2440 is a dc plug reversible model and is compatible with Rotork Controls remotely located model AD-7530 servo amplifier or other compatible control device.

LA-2400 SERIES PRODUCT SPECIFICATIONS

GENERAL SPECIFICATIONS

Speed / Thrust:

Model	in. per sec. / lbf. (mm per sec. / N)			
LA-2410 LA-2415 LA-2450	0.1/800 (2.5/3558)	0.2/800 (5.1/3558)	0.4/200 (10.2/890)	0.7/200 (17.8/890)
LA-2420 LA-2490	0.1/1500 * (2.5/6672)	0.2/1500 * (5.1/6672)	0.4/550 (10.2/2446)	0.7/450 (17.8/2002)
LA-2440	0.2/550 (5.1/2446)	0.25/550 (6.4/2446)	0.6/150 (15.2/667)	1/150 (25.4/667)

*1500 lbf. available in 6 in. stroke only.

Stroke: 6 to 24 in. (152 to 610 mm)

Lubrication & Type: Permanently lubricated, Amoco-Amolith Rykon All-Weather Premium Grease #2.

Gearing: Hardened steel spur gear train, self-locking.

Temperature: -40° F to 150° F. (-40° C to 65° C)

Environment Rating: Dust ignition-proof for Class II, Division I, Groups E, F and G, and Type 4 (IP65) indoor and outdoor.

Enclosure Material: Cast Aluminum Alloy.

Approximate Weight: 40 lbs. (18 kg)

Mounting: Clevis mount in any position.
Trunnion (not available with 6 in. stroke).
When mounted vertically with the ram extending up, option D056 (vertical moisture shield) must be used for wet applications.

Manual Handcrank: Permits local operation.

Thrust Limiting: Bi-directional (factory set and not adjustable).

Modulating Rate: (1% position changes)
LA-2415, 1200 starts/hour.
All others, 2000 starts/hour.

Duty Cycle:
Modulating: LA-2410, LA-2415, LA-2440, LA-2450.
20%: LA-2420, LA-2490.

Clevis: Non-rotating.

ELECTRICAL SPECIFICATIONS

Power Requirements:

Model	Input Power Volts/PH/Hz	Current (Amps)	
		Run	Stall
LA-2410	120/1/50-60	0.9	1.2
LA-2415	240/480/3/50-60	0.4/0.2	1.3/0.65
LA-2415	380/3/50	0.3	0.9
LA-2420	120/1/50-60	2.5	2.9
LA-2440	24 Vdc	1.7	7.5
LA-2450	240/1/50-60	0.45	0.5
LA-2490	240/1/50-60	1.1	1.6

Voltage Tolerance: +/-10%

Conduit Entry: Two, 3/4 NPT.

Field Wiring: To barrier terminal blocks.

OPTIONS

Anti-condensation Heater: 120/240 Vac, 30W

Two auxiliary position limit switches: 5A SPDT,
120/240 Vac

1000 Ohm Feedback Potentiometer: 2 Watt Max.

Contactless Feedback: Hall Effect

4-20mA Feedback Transmitter:
Isolated, loop-powered 12-36 Vdc at 25 mA.

Maximum Load (Ohms) = $\frac{\text{Power Supply Voltage} - 8}{0.020\text{A}}$

Servo-Amplifier Model AD-8130: 120/240 Vac. (For more information see Rotork Controls IM-0523).

Accuracy: +/-1.0% of full rated travel

Repeatability: 0.5% of full rated travel

Hysteresis: 0.5% of full rated travel

Linearity: +/-1.0% of full rated travel

Input Deadband: Adjustable

Loss of Signal: Stays in place or runs to pre-set on current command signals dropping below 3.8 mA (field selectable)

Command Signal Inputs: Field selectable
4 to 20 mA (200 Ohm impedance)
0 to 5 or 0 to 10 Vdc (100,000 Ohm impedance)

High and Low Trim: Adjustable

INSTALLATION

MOUNTING

Refer to installation dimensions on the installation print sent with the actuator. The rear cover (opposite the ram) must have clearance so it can be removed for adjustments and interconnect wiring.

The actuator is mounted with pins through the rear and front clevises. The rear clevis is normally the stationary end. The device to be positioned must be such that it will allow retraction and extension. Side loading must be avoided. Side loading will lead to excessive operating thrust which will cause premature bearing failure. The device to be positioned must not require greater thrust than the rating of the actuator. Mount the rear clevis to the stationary actuator support device first, then move the traveling portion of the device to the front clevis and mount it.

The front clevis is non-rotating. The installation should place no torque upon the clevis or premature failure of the actuator will result.

As an option, trunnion mounting is available on actuators with 12 inch (305 mm) or greater strokes. Dimensional details of this style of mounting is shown on page 18 of this manual.

When mounted vertically with the ram extending up, option D056 (vertical moisture shield) must be used for wet applications.

WIRING

The wiring diagram on page 6 shows the fundamental connections for standard three-wire reversible single-phase ac motor, standard permanent magnet dc motor, and three phase AC models.

The wiring diagram on page 7 shows the fundamental connections for single phase AC actuators with an integral AD-8130 servo-amplifier, along with other options.

A barrier type terminal strip is located under the rear enclosure cover at the rear clevis end of the actuator. Two 3/4 inch NPT conduit entries are available for field use. See the installation dimension drawing on the last page of this manual for their location.

CAUTION: On standard single-phase wiring, the position limit switches and the thrust switches are wired directly in the motor circuit and protect it at the extremes of travel or at thrust cutout. Three phase AC or DC units must have these thrust and position limit switches wired into the controlling device to cause end of travel or thrust shutdown. Care must be taken in wiring these to the controlling device so that the appropriate direction of control is turned off when that direction's limit switch is actuated. If care is not taken in phasing the equipment, damage may occur to the actuator or driven load.

- All wiring must be done in accordance with prevailing codes by qualified personnel.
- Typical wiring diagrams are shown on pages 6-7. **Actual wiring should follow the wiring diagram supplied with the actuator.**
- Fusing must be installed in line power, and should be of the slow blow type.
- Wiring must be routed to the actuator through the two conduit openings. Generally, one conduit will contain input power and earth ground wires. The other conduit would then contain low level input and output signal wiring.
- It is required that all low level signal wiring be a shielded type with the shield grounded at source common.
- After installation, it is recommended that all conduits be sealed to prevent water damage and to maintain NEMA 4 enclosure rating.
- Remote mounted servo amplifiers must maintain a maximum of 50 feet of wire run to the actuator.

TYPICAL WIRING DIAGRAMS

ACTUATOR WITHOUT A BUILT-IN AMPLIFIER

LA-2410, LA-2420 (120 Vac)
LA-2450, LA-2490 (240 Vac)

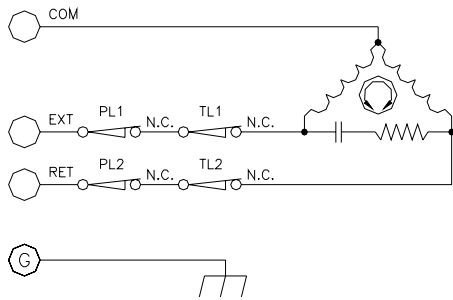

LA-2440 (24 Vdc)

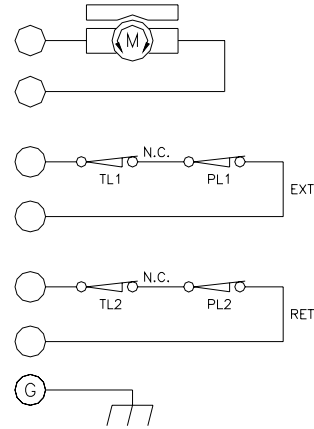

Actuator Action	AC Power Applied to Terminals		DC Power Applied to Terminals	
	1 & 2	1 & 3	1(+) & 2(-)	1(-) & 2(+)
Viewing Actuator Ram	Extend	Retract	Extend	Retract

LA-2415 SERIES ACTUATOR

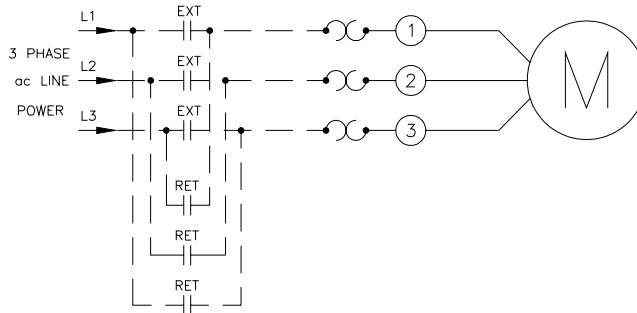

Due to wide variations in terminal numbering of actuator products, actual wiring should follow the print supplied with the actuator.

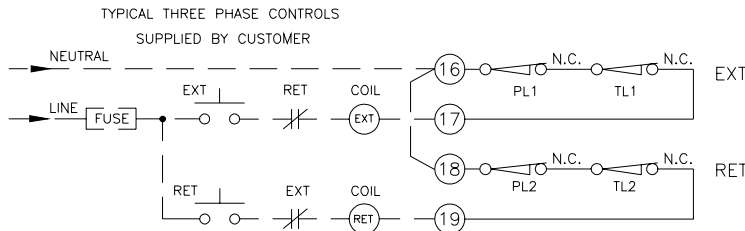

- Notes:**
1. The thrust limit switches (TL1 & TL2) are factory set to trip if the thrust exceeds the actuator rating.
 2. Shielded wire is required for command and position feedback signal wiring.

TYPICAL WIRING DIAGRAM

LA-2400 SERIES ACTUATORS WITH A BUILT-IN AD-8130 AMPLIFIER (120/240 Vac, Single Phase, 50-60 Hz)

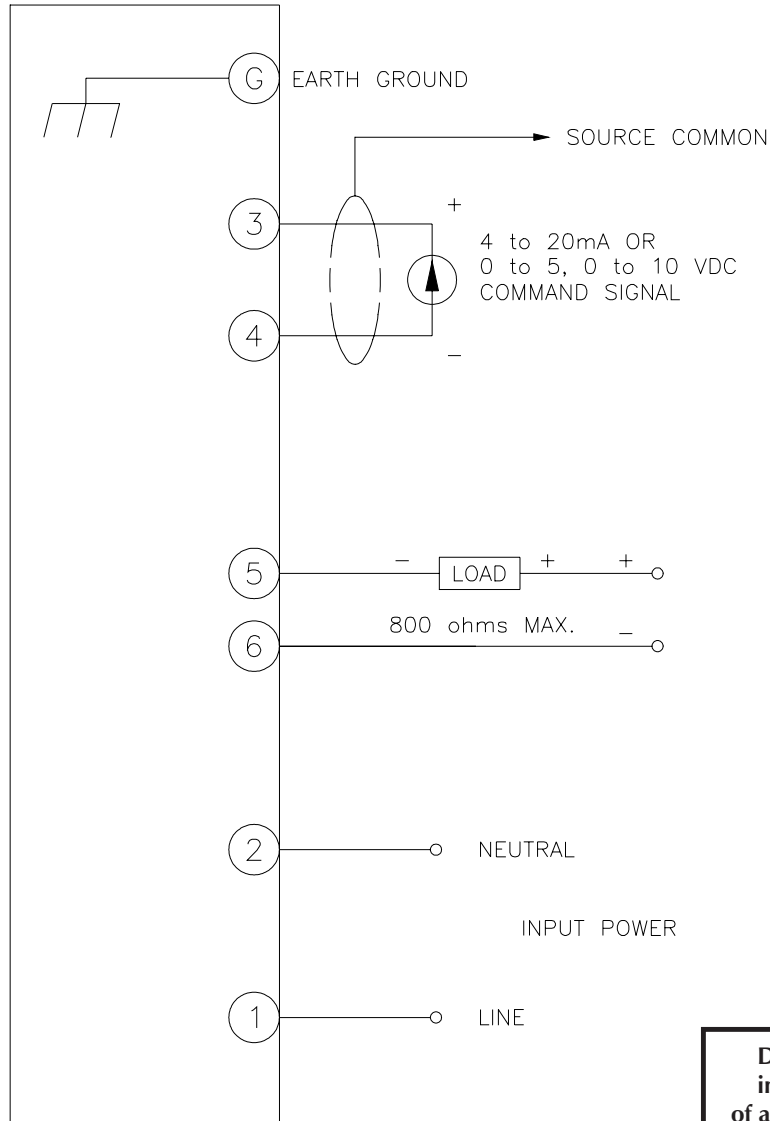

Due to wide variations in terminal numbering of actuator products, actual wiring should follow the print supplied with the actuator.

Notes:

1. All references to actuator ram movement are as viewed facing the front clevis.
2. An increasing command signal will result in ram extension.
3. The thrust limit switches are factory set to trip if the thrust exceeds the actuator rating.
4. Shielded wire is required for command and position feedback signal wiring.
5. Command signal input:
 - 4 to 20 mA into a 200 ohm impedance
 - 0 to 5 or 0 to 10 Vdc into a 100,000 ohm impedance
6. Refer to amplifier instruction manual for proper DIP switch settings and amplifier setup.

START UP & CALIBRATION

A. LIMIT SWITCH ADJUSTMENT PROCEDURE

(see Figure 1)

The limit switch assembly features up to four independently adjustable position limit switches. The setting of one switch does not affect the setting of the other. Limit switch #1 (PL1) is set to stop the actuator at the actuator fully extended position. Limit switch #2 (PL2) is always set to stop the actuator at the actuator fully retracted position. Each limit switch is activated by an aluminum cam with a detent. When the cam roller falls into this detent, the limit switch goes to its normal state. To readjust the limit switches for the required actuator stroke, the following methods are recommended:

FOR ACTUATOR WITHOUT A POSITION FEEDBACK DEVICE

1. With no power applied to the circuits, manually turn the manual handwheel until there is a slight gap (1/32") between the front clevis and the outer support tube with the clevis hole in the required mounting plate.

CAUTION: Do not energize the actuator while manual positioning or attempt to engage the manual handwheel while the unit is running. Rotation of the manual handwheel by the motor could inflict personal injury.

2. Loosen both set screws in PL2 cam (set screws are 120° apart). Rotate PL2 cam until the indent of the cam and the roller begin to mate and the limit switch activates (when you hear a "click"). Tighten the set screws.
3. Energize the motor and run front clevis to the fully extended position. Loosen both the set screws of PL1 cam and manually rotate the cam until the indent of the cam and the roller begin to mate and the limit switch activates (when you hear a "click"). Tighten the set screws.

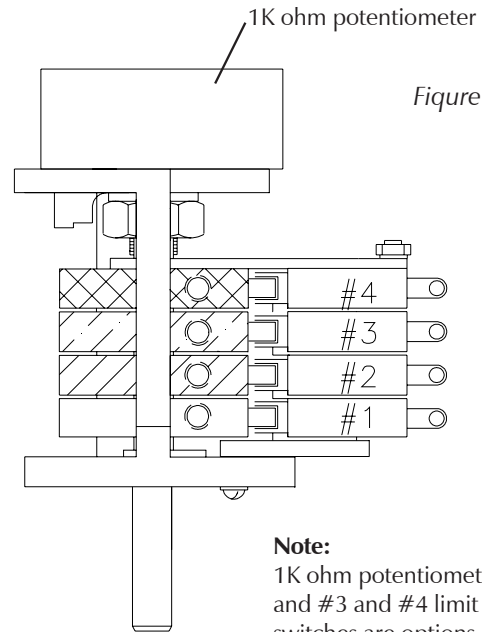

4. The end of travel position limits PL1 and PL2 are now set for full stroke of the actuator.
5. Apply electrical power and run the actuator through its range to check for proper limit switch adjustment.

FOR ACTUATOR WITH A POSITION FEEDBACK DEVICE

1. With no power applied to the circuits, connect an ohm meter across the potentiometer wiper arm and the "zero" (retract) end of the pot.
2. Follow steps 1 through 5 in the previous section.

START UP & CALIBRATION

A. POSITION FEEDBACK ALIGNMENT (Potentiometer)

Position feedback is provided through the use of a potentiometer attached to the limit switch assembly. As the switches are driven by the actuator gearing, the potentiometer is simultaneously driven to provide position feedback.

1. Establish if full extend or full retract is to be used for zero indication. On slide gate installations, zero indication is normally used when the actuator is fully extended and the gate closed.
2. Make sure end of travel limit switches are correctly set for proper stroke length.
3. Use an ohmmeter to monitor the position of the feedback potentiometer wiper to determine which end of the pot gives a low ohm resistance indication.
4. If the reading is greater than 50 Ohms, see Position Limit Switch Adjustment Procedure for actuators with a potentiometer.
5. Run the actuator through its stroke range to ensure the potentiometer is tracking through its electrical range. (Generally 60 to 90% of 1,000 Ohms).

NOTE: On tandem potentiometer assembly, set the bottom potentiometer to approximately 50 Ohms.

B. POSITION FEEDBACK ALIGNMENT (Contactless)

Position feedback can also be provided through the use of a contactless feedback device attached to the limit switch assembly. As the switches are driven by the actuator gearing, the feedback device is simultaneously driven to provide position feedback.

C. 4 to 20mA TRANSMITTER ADJUSTMENT

The ST-4130 (1000 Ohm-input, 4 to 20mA output) two wire transmitter modulates the current on a direct current supply proportional to the input resistance. It is powered by a 12.0 to 36.0 Vdc unregulated power supply line which is modulated from 4 to 20mA proportional to the resistance of the input.

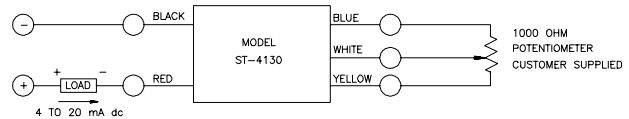

800 ohm maximum load when power supply is 24 Vdc

For the unit to function properly the 4mA end of the feedback potentiometer must be preset to 50 Ohms.

1. Position the actuator to the desired 4mA setting. Resistance of the potentiometer must be measured without the ST-4130 connected.
2. With potentiometer resistance at 50 Ohms, adjust ELEVATION for 4.0mA output.
3. Position the actuator to the desired 20mA setting.
4. Adjust RANGE for 20mA output.
5. Repeat steps 1 through 4 until no further adjustment is necessary.
6. To reverse the 4 and 20mA output, interchange the BLUE and YELLOW wires at the terminal block and return to step 1.

START UP & CALIBRATION FOR UNITS WITH AMPLIFIERS

Switch and feedback device alignment is accomplished in the same manner as actuator without amplifiers, except motor power is supplied from the amplifier. Varying the command signal input to the amplifier will allow you to reverse the extension or retraction of the shaft to run to the minimum/maximum switch settings.

If the actuator does not run to the limit switch but stops short and both red lights are off on the amplifier board, the amplifier has nulled and adjustments of span, elevation, loss of signal, or feedback potentiometer may be required.

Amplifier Specifications

Standard Line Voltage: 120/240Vac, $\pm 10\%$, 50/60 Hz (Slide switch select) (Voltage input **MUST** match the actuator motor voltage rating).

Power Consumption: Less than 20 watts for amplifier functions only.

Voltage Output: Identical to voltage input.

Current Output: 10 amps max. at 120 or 240 Vac.

Fuse protection: Customer supplied. Size based on actuator controlled and local codes.

Null output (AD-8240): Rated 2 amperes @120/240Vac, 50/60Hz.

Command Signal Inputs:

- 4-20mA, 4-12mA, 12-20mA into a 200 Ω shunt resistor
- 0-5Vdc into 100,000 Ω impedance
- 0-10Vdc into 100,000 Ω impedance

Position Feedback Signal: 1000 Ω potentiometer 4-20mA

Position Output Signal: Isolated 4-20mA, loop powered with 12-36Vdc external power supply.

Field Wiring Terminations: Plugable terminal block, wire size range 26-14 AWG.

Command Signal Monitor: The amplifier's loss-of-signal circuitry monitors the command signal input. If the command signal drops below or above the rating, the actuator will either lock in place or run to a preset position (user selectable).

Limit Signals: *Internal:* Part of servo control.

Output Shaft Motion: All models can go either direction on an increasing command signal. This is determined by the ZERO and SPAN settings.

Temperature Limits: -40° to 150° F (-40° to 65° C).

Duty Cycle: Unrestricted modulating duty. (Cont. duty).

Position Accuracy: 1% of full range.

Deadband: Factory preset to 1%. Field adjustable.

Amplifier Start-Up

- 1) **Power.** Before applying AC power to TB2 set slide switch to the correct voltage (120/240Vac)
- 2) **Command Calibration.** This procedure calibrates the minimum and maximum command to the unit.
 - A) Set command signal to low level, normally 4 mA.
 - B) Depress ZERO pushbutton (S1) and LOS pushbutton (S4) until the SPARE LED illuminates.
 - C) Set command signal to high level, normally 20 mA.
 - D) Depress SPAN pushbutton (S2) and LOS pushbutton (S4) until the SPARE LED illuminates.
- 3) **Auto/Manual (Option).** If the unit has the Auto/Manual switch option, place it in the auto position.
- 4) **Setpoints.** These are the end of travel extremes corresponding to the actuator output shaft positions for low (4mA) and high (20mA) command signal levels. They are set by the ZERO and SPAN pushbuttons and adjusting knob. All settings require the holding of a push button *and* the turning of the adjusting knob.
 - A) Set the command signal to lowest level, normally 4mA.
 - B) Adjust LO setpoint (ZERO) by holding ZERO push button (S1) and turning adjusting knob to move actuator output shaft to desired position. Turn the adjusting knob CW to extend the output shaft. Turn the adjusting knob CCW to retract the output shaft. Release button.
 - C) Set the command signal to highest level, normally 20mA.
 - D) Adjust HI setpoint (SPAN) by holding SPAN push button (S2) and turning adjusting knob to move actuator output shaft to desired position. Turn the adjusting knob CW to extend the output shaft. Turn the adjusting knob CCW to retract the output shaft. Release button.
- 5) **Transmitter.** This adjustment sets the endpoints of the 4-20 mA transmitter to account for variations in accuracy of the input command.
 - A) Set command signal to low level, normally 4 mA.
 - B) Depress ZERO pushbutton (S1) and LOS pushbutton (S4) until the SPARE LED illuminates. While depressing pushbuttons, turn adjusting knob CW to increase the 4 mA point, or CCW to decrease the 4 mA point.
 - C) Set command signal to high level, normally 20 mA.
 - D) Depress SPAN pushbutton (S2) and LOS pushbutton (S4) until the SPARE LED illuminates. While depressing pushbuttons, turn adjusting knob CW to increase the 20 mA point, or CCW to decrease the 20 mA point.
- 6) **Deadband.** This adjustment establishes the actuator servo sensitivity. It is factory set at 1% and should not be field adjusted. If the actuator begins to oscillate (Green and Yellow LEDs turn on and off rapidly), decrease the sensitivity by holding deadband push button (S3) and turning adjusting knob CW until oscillation stops. Release button.
- 7) **Loss of Signal Preset.** This adjustment establishes the position to which the actuator will travel upon a loss of command signal condition. To activate this setting, SW3 must be OFF. Adjust the setting by holding the LOS push button (S4) and turning the adjusting knob to set the preset position. Turn the adjusting knob CW to extend the output shaft for linear actuators, or rotate the output shaft CW for rotary actuators. Turn the adjusting knob CCW to retract the output shaft for linear actuators, or rotate the output shaft CCW for rotary actuators.
- 8) **Verify all settings** by running the actuator through its travel range several times.

Amplifier Parts Identification

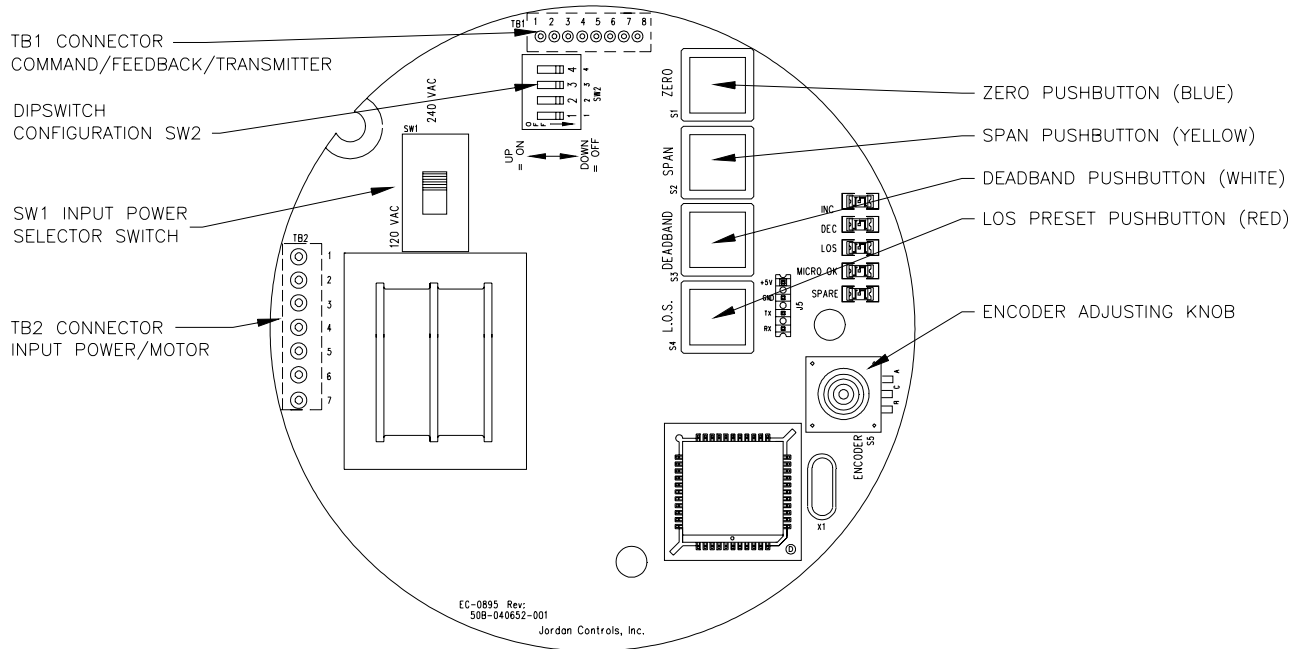

Amplifier DIP Switch Chart

DIP Switch Configurations SW2		
Switch	Switch Position	Function
1	ON (Up)	Current Command
	OFF (Down)	0-5V / 0-10V Voltage Command
2	ON (Up)	0-5V Voltage Command
	OFF (Down)	Current / 0-10V Command
3	ON (Up)	LOS Lock-in-Place
	OFF (Down)	LOS Preset Position
4	ON (Up)	Dynamic Brake On
	OFF (Down)	Dynamic Brake Off

Typical Amplifier Wiring Diagram

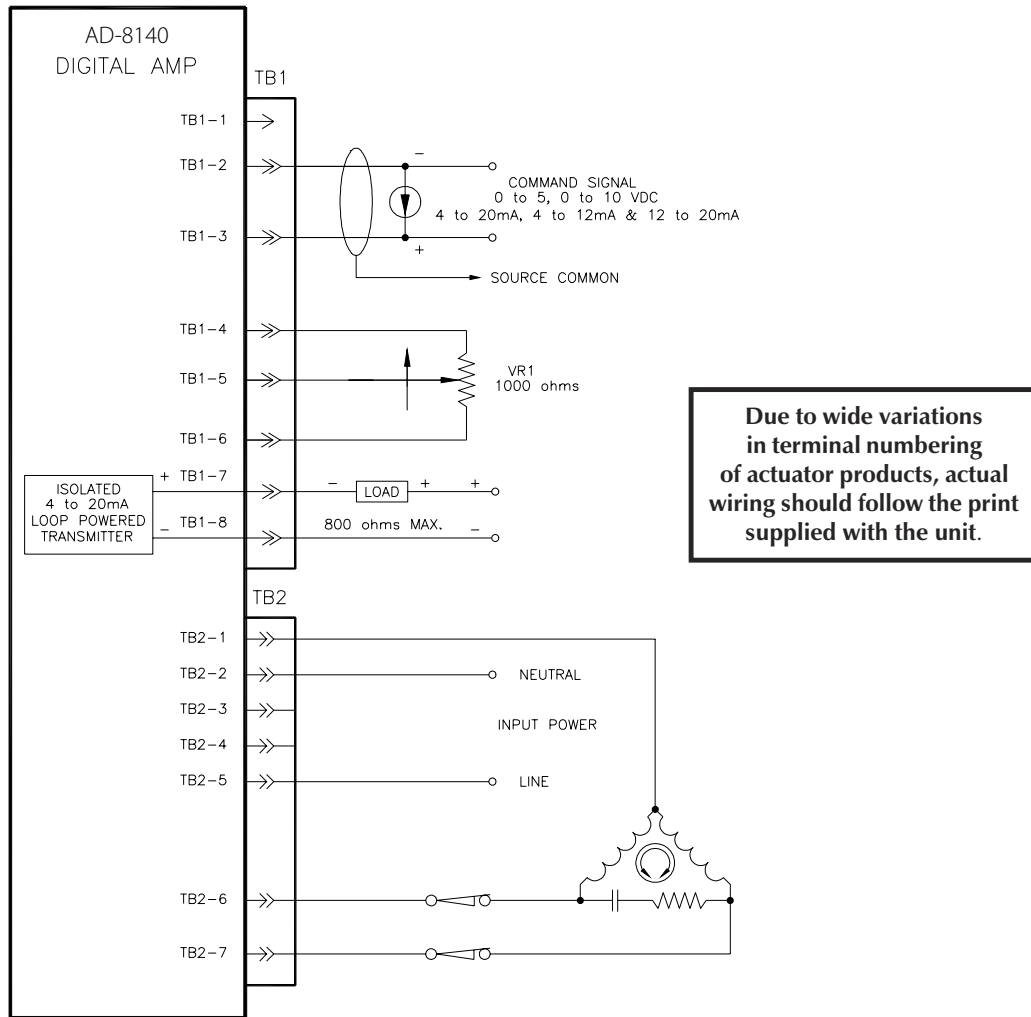

Troubleshooting

For visual troubleshooting, LEDs are provided to display the status of the actuator. These are located on the same side of the lower board as SW1. The identification of these LEDs are shown in the table below.

LED	Function
MICRO OK	This LED flashes when the microprocessor is running. If this is not on, verify power to the board.
INC.	This LED is on when the actuator is extending the output shaft for linear actuators, or rotating the output shaft CW for rotary actuators.
DEC.	This LED is on when the actuator is retracting the output shaft for linear actuators, or rotating the output shaft CCW for rotary actuators.
L.O.S.	1 Flash - Indicates loss of 4-20 mA signal (LOS).
	2 Flashes - Indicates loss of the feedback signal.
	3 Flashes - Indicates indicates a stall condition.

TROUBLESHOOTING GUIDE

TROUBLE	POSSIBLE CAUSE	REMEDY
Motor won't operate	a. No power to actuator	a. Check source, fuses, wiring
	b. Motor overheated and internal thermal switch tripped (single phase AC motors only)	b. Let motor cool and determine why overheating occurred (such as, excessive duty cycle or ambient temperature)
	c. Motor defective	c. Replace motor and determine cause of failure
	d. Both end of travel position limit switches open or one open and one defective	d. Adjust switch settings or replace defective switch
	e. Actuator ram stalled (mechanically jammed)	e. Check drive load for mechanical jam and correct cause
	f. Defective motor run capacitor (single phase ac motors only)	f. Replace capacitor
	g. Load exceeds actuator thrust rating	g. Reduce load or replace actuator with one with appropriate thrust rating
	h. Power applied to extend & retract at same time	h. Correct power input problem
	i. Amplifier defective	i. Replace amplifier
	j. Amplifier is in Loss of Signal	j. Check command signal to verify signal greater than 3.8 mA is present
Ram positions in wrong direction for extend and retract input power	a. Wiring to actuator incorrect	a. Correct field wiring
	b. Wiring from motor to terminals or switches is reversed	b. Correct internal actuator wiring
Motor hums, but does not run	a. Power applied to extend & retract at the same time	a. Correct power input problem
	b. Damaged power gearing	b. Repair gearing
	c. Defective motor run capacitor (single phase ac motors only)	c. Replace capacitor
	d. Damaged servo amplifier	d. Replace servo amplifier
Motor runs, but ram does not move	a. Defective power gearing	a. Repair gearing
	b. Screw drive nut stripped or pulled out of tube	b. Repair or replace screw drive nut
Motor does not shut off at limit switch	a. Switch wired wrong or is defective	a. Correct wiring or replace switch
	b. Switches are not aligned	b. Align switches

TROUBLESHOOTING GUIDE

TROUBLE	POSSIBLE CAUSE	REMEDY
Thrust limit switch operation	a. Thrust limit switch not properly wired to control circuit	a. Correct wiring per diagram
	b. Thrust limit switch collars loose or not properly adjusted	b. Adjust and tighten collars as required
	c. Thrust limit switch defective	c. Replace
	d. Thrust limit switch bent and binding	d. Replace shaft
	e. Thrust limit switch mounting or bushing is bent or damaged	e. Replace as required
	f. Thrust limit switch mounting block not aligned or secured	f. Align and secure blocks as required
	g. The actuator is overloaded	g. Remove overload
Motor runs, but only one way	a. Power not applied for other direction	a. Correct power problem
	b. Power always applied to one direction and electrically stalls when applied for opposite direction	b. Correct power problem
	c. Open limit switch for other direction	c. Adjust or replace limit switch as required
	d. Actuator is in thrust overload	d. Determine obstruction and correct
	e. Motor has an open winding	e. Replace motor
	f. Motor and feedback potentiometer are out of phase	f. Reverse potentiometer end leads
	g. Amplifier is defective	g. Replace amplifier
Poor response to command signal changes	a. Amplifier deadband is too wide	a. Reduce deadband setting
	b. Amplifier is defective	b. Replace amplifier
	c. Excessive noise on command signal	c. Reduce noise. Also ensure that command signal wiring is shielded with shield grounded at source common only
Actuator oscillates at setpoint	a. Amplifier deadband is too narrow	a. Increase deadband setting
	b. Amplifier is defective	b. Replace amplifier
	c. Excessive noise on command signal	c. Reduce noise. Also ensure that command signal wiring is shielded with shield grounded at source common only
Pot feedback signal not always present during actuator ram movement	a. Pot not aligned with end of travel extremes and is being driven through its dead region	a. Align pot to range of actuator
	b. Pot signal is erratic or nonexistent	b. Replace pot
Pot signal does not change as actuator operates	a. Defective pot	a. Replace pot
	b. Feedback gear not turning pot shaft	b. Check gearing engagement and set screw in gear hub
Pot signal is reversed for output ram direction	a. Pot is wired wrong	a. Reverse wiring from ends of pot at actuator terminal block
Water droplets inside motor area of actuator	a. Condensation caused by temperature variations and humidity	a. Add heater and thermostat circuit and ensure that existing circuit is continuously energized. Check conduit entry and seal to prevent water from entering via the conduit
	b. Water entering actuator	b. Ensure rear cover gasket is in place and replace if defective. Also ensure all cover bolts are in place and tightened. Check conduit entry and seal to prevent water from entering via the conduit. Order optional bellows kit if needed

Note: For actuators controlled by servo-amplifiers, refer to that servo-amplifier's instruction manual for additional troubleshooting information.

COMPONENT IDENTIFICATION

- | | |
|--------------------------------|---|
| 1. Actuator Housing | 20. Feedback Assembly |
| 2. Feedback Housing | 21. Thrust Limit Switch (2) |
| 3. Motor Cover | 22. Motor Pinion |
| 4. Feedback Cover | 23. Power Idler Gear Assembly |
| 5. Outer Tube | 24. Feedback Idler Gear Assembly |
| 6. Inner Tube Assembly | 25. Limit Switch Gear |
| 7. Clevis, Stationary | 26. Drive Screw Gear |
| 8. Clevis, Tube | 27. Drive Screw |
| 9. Housing Gasket | 28. Handcrank Gear |
| 10. Cover Gasket | 29. Handcrank |
| 11. O' Ring, Stationary Clevis | 30. Spring Pack Assembly |
| 12. O' Ring, Tube Clevis | 31. Drive Screw Guide |
| 13. Seal, Handcrank | 36. Tube Clevis Roll Pin |
| 14. Tube Scraper | 41. Limit Switch Gear Set Screws |
| 15. Tube Seals | 42. Limit Switch Assembly Mounting Screws |
| 16. Tube Spacer | 43. Tube Bearing and Seal Retaining Ring |
| 17. Tube Bearing | 44. Drive Screw Guide Retaining Ring |
| 18. Motor | 49. Drive Nut |
| 19. Motor Top (1phase ac only) | 50. Potentiometer |
| | 51. Noncontact Feedback Module |

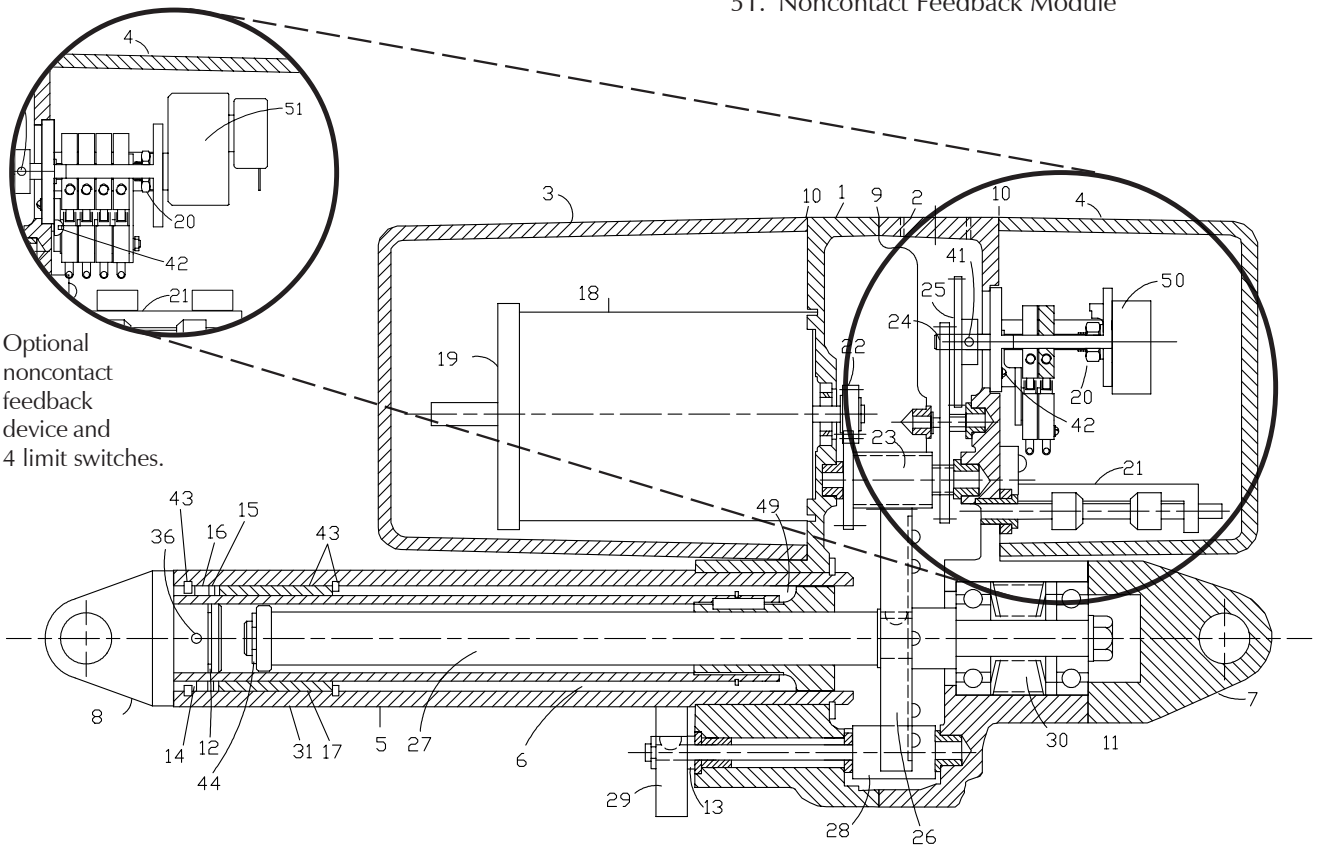

COMPONENT IDENTIFICATION

DC Motor Side

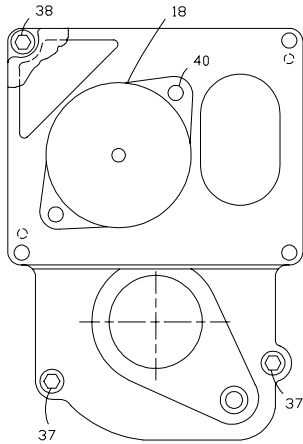

Feedback Side with Amp

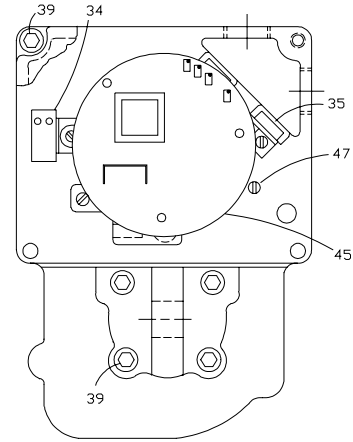

AC Motor Side (1 phase)

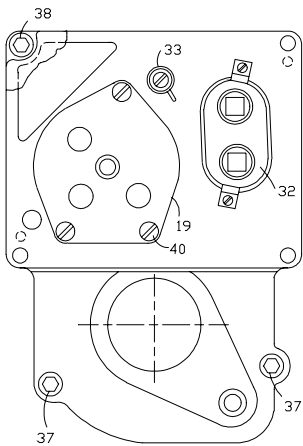

Feedback Side

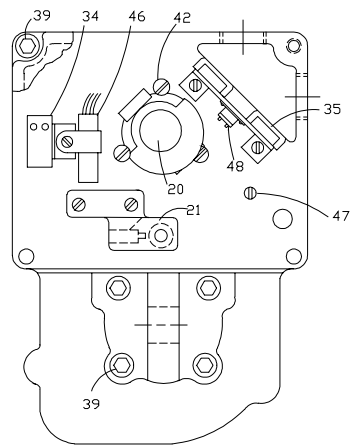

- | | |
|--|--------------------------|
| 18. Motor | 37. Housing Bolts |
| 19. Motor Top (1 phase ac only) | 38. Motor Cover Bolts |
| 20. Feedback Assembly | 39. Feedback Cover Bolts |
| 21. Thrust Limit Switch Assembly | 40. Motor Mounting Bolts |
| 32. AC Motor Capacitor (1 phase ac only) | 45. AD-8130 Amplifier |
| 33. AC Motor Resistor (1 phase ac only) | 46. Heater |
| 34. ST-4130 Loop Powered 4-20 mA Transmitter or EC-10883 analog conversion module for contactless feedback | 47. Ground Screw |
| 35. Terminal Strip | 48. Thermo Switch |

MAINTENANCE

Under normal service conditions, the motor, gearing, bearings, and parts do not require periodic maintenance. If for any reason the unit is disassembled in the field, all Oilite bushings should be saturated with S.A.E. 20 or 30 non-detergent oil and all gearing heavily coated with Amoco-Amolith Rykon all weather premium grease #2 or equal.

Care should be taken to ensure that no foreign material is in the grease, which could cause premature failure. The screw shaft must be lubricated with Alex EP1L grease. DO NOT SUBSTITUTE.

Refer to Pages 16 and 17 for component locations.

To Separate Housings:

- A. Disconnect motor wires which run through housing.
- B. Extend front clevis to obtain access to roll pin 36.
- C. Remove roll pin 36 and front clevis 8.
- D. Remove housing screws 37, 38 and 39.
- E. Separate housing assemblies and remove gears 23 and 24.

To Remove Motor 18:

- A. Separate housings.
- B. If gear 22 is held to motor shaft with a retaining ring, remove the ring and gear 22.
- C. Remove screws 40.
- D. Remove motor top 19. (ac motor only).
- E. Remove motor stator and rotor 18.

To Remove Multi-turn Feedback Assembly 20:

- A. Separate housings.
- B. Loosen set screws 41 and remove gear 25.
- C. Remove screws 42.
- D. Remove feedback assembly 20.

To Remove Single-turn Feedback Assembly 20:

- A. Separate housings.
- B. Loosen set screws 41 and remove gear 25.
- C. Remove screws 42.
- D. Remove feedback assembly 20.

To Change Tube Bearing 17 or Seals 15:

- A. Separate housings.
- B. Remove outer retaining ring 43.
- C. Remove scraper 14, spacer 16, seals 15 and tube bearing 17.

To Remove Inner Tube Assembly 6:

- A. Separate housings.
- B. Remove retaining ring 44 and guide 31.
- C. Hold screw shaft gear 26 and turn tube 6 to unscrew from shaft.

POWER GEARING SELECTION CHART

(All Stroke Lengths)

Actuator Voltage	Stroke Speed	Motor Pinion Gear	Power Idler Gear Assembly
120 or 240 Vac 240/380/480 Vac 3 phase	0.1" + 0.2"/sec.	16A-017896-001	65A-016334-002
	0.4" + 0.7"/sec.	16A-017895-001	65A-016334-001
24 Vdc	0.2" + 0.25"/sec.	16A-017896-001	65A-016334-002
	0.6" + 1.0"/sec.	16A-017895-001	65A-016334-001

Single Turn Feedback Gearing & Drive Nut Selection Charts

LA-2410, LA-2415, LA-2420, LA-2450, LA-2490 (0.1"/sec. & 0.4"/sec.); LA-2440 (0.2"/sec. & 0.6"/sec.)

Stroke	1st Stage Gear	2nd Stage Gear	Feedback Gear	Drive Nut (3/4 - 10)
3"	65B-025344-004	N/A	16B-003803-133	61A-039553-003
4"	65B-025344-009	N/A	16B-003803-151	61A-039553-003
5"	65B-025344-001	N/A	16B-003803-109	61A-039553-003
6"	65A-017619-001	65A-025339-001	16B-003803-130	61A-039553-003
7"	65A-017619-001	65A-021042-001	16A-021043-001	61A-039553-003
9"	65A-017619-001	65A-017620-003	16B-003803-042	61A-039553-003
12"	65A-017619-001	65A-017620-003	16B-003803-131	61A-039553-003
15"	65A-017619-001	65A-021042-004	16B-003803-042	61A-039553-003
18"	65A-017619-001	65A-021042-005	16B-003803-133	61A-039553-003
24"	65A-017619-001	65A-021042-006	16B-003803-132	61A-039553-003

LA-2410, LA-2415, LA-2420, LA-2450, LA-2490 (0.2"/sec. & 0.7"/sec.); LA-2440 (0.25"/sec. & 1.0"/sec.)

Stroke	1st Stage Gear	2nd Stage Gear	Feedback Gear	Drive Nut (3/4 - 6)
3"	65B-025344-003	N/A	16B-003803-131	61A-039553-002
4"	65B-025344-007	N/A	16B-003803-149	61A-039553-002
5"	65B-025344-004	N/A	16B-003803-133	61A-039553-002
6"	65B-025344-002	N/A	16B-003803-132	61A-039553-002
7"	65B-025344-008	N/A	16B-003803-150	61A-039553-002
9"	65B-025344-001	N/A	16B-003803-109	61A-039553-002
12"	65A-017619-001	65A-021042-001	16A-021043-001	61A-039553-002
15"	65A-017619-001	65A-017620-003	16B-003803-042	61A-039553-002
18"	65A-017619-001	65A-017620-002	16B-003803-112	61A-039553-002
24"	65A-017619-001	65A-021042-002	16B-003803-050	61A-039553-002

Multi Turn Feedback Gearing & Drive Nut Selection Charts

LA-2410, LA-2415, LA-2420, LA-2450, LA-2490 (0.1"/sec. & 0.4"/sec.); LA-2440 (0.2"/sec. & 0.6"/sec.)

Stroke	1st Stage Gear	2nd Stage Gear	Limit Switch Gear	Drive Nut (3/4 - 10)
6"	65B-025344-004	N/A	16B-003803-133	61A-016350-001
12"	65A-017619-001	65A-025339-001	16B-003803-130	61A-016350-001
18"	65A-017619-001	65A-017620-003	16B-003803-042	61A-016350-001
24"	65A-017619-001	65A-021042-003	16B-003803-131	61A-039553-003

LA-2410, LA-2415, LA-2420, LA-2450, LA-2490 (0.2"/sec. & 0.7"/sec.); LA-2440 (0.25"/sec. & 1.0"/sec.)

Stroke	1st Stage Gear	2nd Stage Gear	Limit Switch Gear	Drive Nut (3/4 - 6)
6"	65B-025344-003	N/A	16B-003803-131	14A-016378-001
12"	65B-025344-002	N/A	16B-003803-132	14A-016378-001
18"	65B-025344-001	N/A	16B-003803-109	14A-016378-001
24"	65B-017619-001	65A-021042-001	16A-021043-001	61A-039553-002

PARTS LIST

Recommended Spare Parts Indicated in Bold

ID	Description	Part Number	Quantity
1	Motor Housing - ac Units	60D-042926-002	1
	Motor Housing - dc Units	60D-042926-003	1
2	Feedback Housing w/o Amp	60D-023767-001	1
	Feedback Housing with Amp	60D-023767-001	1
3	Motor Cover	60C-016326-001	1
4	Feedback Cover w/o Amp	60C-016328-001	1
	Feedback Cover with Amp (or with 21P option)	60C-016326-001	1
5	Outer Tube, 6" stroke	61B-040118-001	1
	Outer Tube, 12" stroke	61B-040118-002	1
	Outer Tube, 18" stroke	61B-040118-003	1
	Outer Tube, 24" stroke	61B-040118-004	1
6	Inner Tube, 6" stroke	61B-039536-001	1
	Inner Tube, 12" stroke	61B-039536-002	1
	Inner Tube, 18" stroke	61B-039536-003	1
	Inner Tube, 24" stroke	61B-039536-004	1
	Tube Bearing	61A-016376-001	1
	Retaining Ring	58B-014184-102	2
	Washer	74A-016377-001	2
	Retaining Ring	58B-019899-016	2
	Key	61A-012228-001	1
	Shim Spacer	13A-014549-006	A/R
7	Rear Clevis	60B-016330-001	1
8	Front Clevis	60A-016346-001	1
9	Gasket, Main Housing	13C-016366-001	1
10	Gasket, Cover	13B-016367-001	2
11	O Ring, Rear Clevis	74B-010957-133	1
12	O Ring, Front Clevis	74B-010957-020	1
13	Seal, Handwheel Shaft	19B-003815-021	1
14	Scraper	13A-012877-001	1
15	Tube Seal	19A-012878-000	2
16	Tube Spacer	61A-012876-001	1
17	Tube Bearing	61A-016348-001	1
18	Motor, LA-2410, 0.1" or 0.2" / sec.	61B-042938-002	1
	Motor, LA-2410, 0.4" or 0.7" / sec.	61B-042933-005	1
	Motor, LA-2415, 0.1" or 0.2" / sec.	23B-037613-001	1
	Motor, LA-2415, 0.4" or 0.7" / sec.	23B-0037614-001	1
	Motor, LA-2420, 0.1" or 0.2" / sec.	61B-0042938-006	1
	Motor, LA-2420, 0.4" or 0.7" / sec.	61B-042933-001	1
	Motor, LA-2440, 0.2" or 0.25" / sec.	61B-026405-001	1
	Motor, LA-2440, 0.6" or 1.0" / sec.	61B-026404-001	1
	Motor, LA-2450, 0.1" or 0.2" / sec.	61B-042938-003	1
	Motor, LA-2450, 0.4" or 0.7" / sec.	61B-042500-001	1
	Motor, LA-2490, 0.1" or 0.2" / sec.	61B-042938-005	1
	Motor, LA-2490, 0.4" or 0.7" / sec.	61B-042933-004	1
19	Motor Top (1 phase ac units only)	60C-042348-001	1
	Belleville Washers (1 phase ac units only)	56A-005478-001	2

PARTS LIST

Recommended Spare Parts Indicated in Bold

ID	Description	Part Number	Quantity
20	Single Turn Feedback:		
	Position Limit Switch, SPDT	46B-004053-405	2
	Position Limit Switch, DPDT	46B-004053-414	2
	1K Potentiometer	34B-0033104-001	1
	1K/1K Potentiometer	34B-003956-160	1
	Hall Effect Sensor	70B-039960-002	1
	Multi Turn Feedback:		
	Travel Nut	14B-008602-001	1
	Position Limit Switch, SPDT	46B-004053-409	2
	Position Limit Switch, DPDT	46B-004053-414	2
	1K Potentiometer	34B-100033-001	1
	1K/1K 10 Turn Potentiometer	34B-100033-007	1
21	Thrust Limit Switch	46B-004053-405	2
22	Motor Pinion Gear	See Selection Chart	1
23	Power Idler Gear Assembly	See Selection Chart	1
24	Feedback Gearing	See Selection Chart	1
25	Feedback Gear	See Selection Chart	1
26	Screw Gear	16B-023764-001	1
27	Drive Screw:		
	6 inch, 3/4 - 10	62C-016356-001	1
	12 inch, 3/4 - 10	62C-016356-002	1
	18 inch, 3/4 - 10	62C-016356-003	1
	24 inch, 3/4 - 10	62C-016356-004	1
	6 inch, 3/4 - 6	62C-016355-001	1
	12 inch, 3/4 - 6	62C-016355-002	1
	18 inch, 3/4 - 6	62C-016355-003	1
	24 inch, 3/4 - 6	62C-016355-004	1
28	Handwheel Gear Assembly	68A-018955-001	1
29	Handwheel	61A-016343-001	1
30	Thrust Spring Pack Assembly	Consult Factory	1
31	Drive Screw Guide	14A-012868-001	1
32	Capacitor:		
	12.5 mfd, LA-2410, .1", .2", .4", .7" / sec.	24B-029812-027	1
	35 mfd, LA-2420	24B-029812-026	1
	5 mfd, LA-2450	24B-029812-028	1
	7.5 mfd, LA-2490	24B-029812-030	1
33	Resistor, LA-2410, LA-2450	33B-003852-205	1
	Resistor, LA-2420, LA-2490	33B-003852-305	1
34	ST-4130 Transmitter	70A-019948-001	1
35	Terminal Block	43B-003888-107	2
36	Roll Pin	57A-015215-125	1
37	Cap Screw	54A-015070-175	2
38	Cap Screw	54A-015070-200	4
39	Cap Screw	54A-015070-100	8
40	Screw, LA-2410	54A-015044-375	3
	Screw, LA-2420, LA-2490	54A-015044-500	3
	Screw, LA-2450	54A-015044-450	3

PARTS LIST

Recommended Spare Parts Indicated in Bold

ID	Description	Part Number	Quantity
41	Set Screw	54A-015037-019	2
42	Screw, Truss Head	54A-015032-025	3
43	Retaining Ring	58B-014185-162	2
44	Retaining Ring	58B-014183-050	1
45	AD-8140 Amplifier	68C-041180-001	1
46	Heater, 120 Vac	74A-016946-001	1
	Heater, 240 Vac	74A-031965-001	1
47	Ground Screw	58B-024244-152	1
48	Thermoswitch	74A-023565-001	1
49	Drive Nut	See Selection Chart	1
50	Screw Shaft Grease	73A-032878-001	1

INSTALLATION DIMENSIONS

(Trunnion Mount)

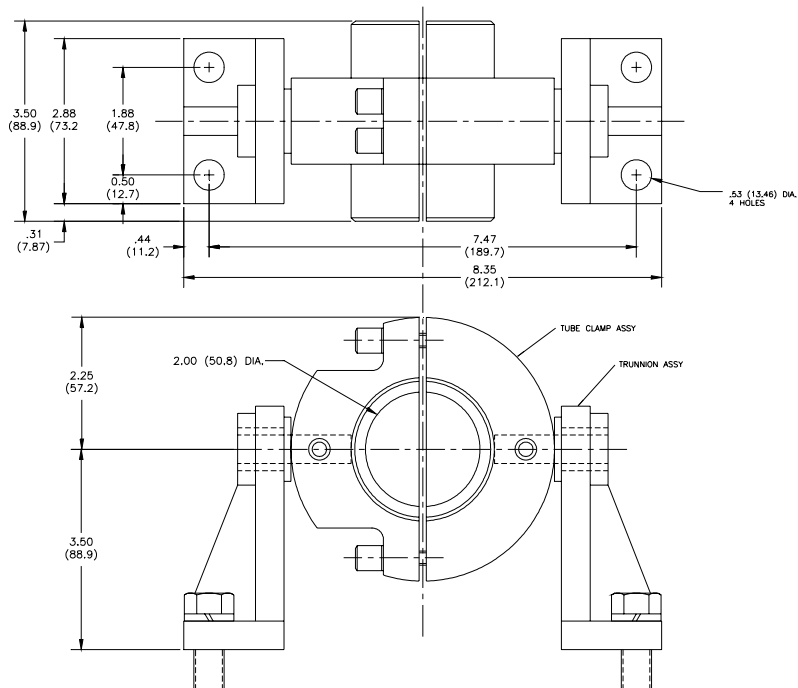

LA-2400 MAJOR DIMENSIONS

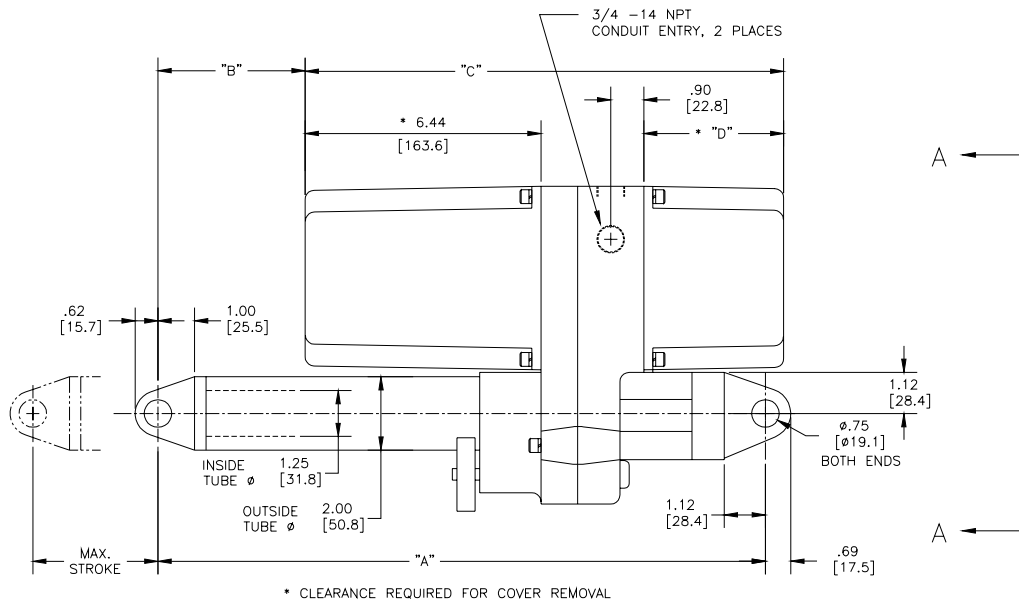

INCHES
[MILLIMETERS]

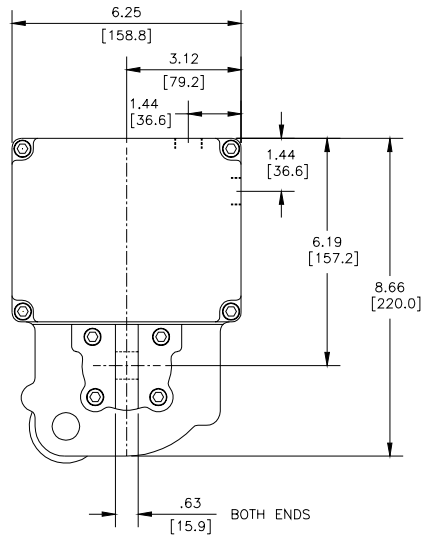

VIEW A-A

Stroke in. (mm)	A	B	C		D	
			Without Amp	With amp	Without Amp	With amp
2 (51) to 6 (152)	16.16 (410)	4.01 (102)	13.1 (333)	15.73 (400)	3.81 (97)	6.44 (164)
6.01 (153) to 12 (305)	22.61 (574)	10.01 (254)	13.1 (333)	15.73 (400)	3.81 (97)	6.44 (164)
12.01 (305) to 18 (457)	28.61 (727)	16.01 (407)	13.1 (333)	15.73 (400)	3.81 (97)	6.44 (164)
18.01 (457) to 24 (610)	34.61 (879)	22.01 (559)	13.1 (333)	15.73 (400)	3.81 (97)	6.44 (164)

These dimensions are subject to change without notice and should not be used for preparation of drawings or fabrication of installation mounting. Current installation dimension drawings are available upon request.

Notes



Notes



Notes



rotork®

Redefining Flow Control

www.rotork.com

A full listing of our worldwide sales and service network is available on our website.

Rotork plc
Brassmill Lane, Bath, UK
tel +44 (0)1225 733200
fax +44 (0)1225 333467
email mail@rotork.com

USA
Rotork Controls
tel +1 (585) 247 2304
fax +1 (585) 247 2308
email info@rotork.com

Scan with your smart phone
for more information on
this product range

