

rotork[®]

Process Controls

1000 Series Installation Manual

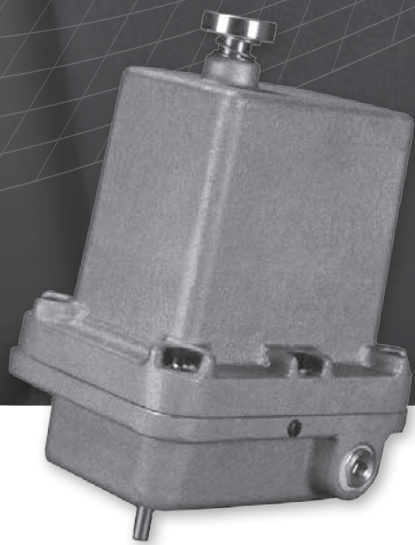

Linear Actuators

Redefining Flow Control

Contents

rotork® Process Controls

Section	Page	Section	Page
Introduction	3	VA-1000 Speed/Thrust Curve	19
General Information	4-5	VA-1000 Major Dimensions	20
Specifications	6	Installation Wiring	21
Optional Merla Valve Mounting	7	Start-up Information	22-23
Physical Installation	7	Lower PC Board Diagram	23
MV-1000 Component Identification	8	Typical Wiring Diagram	24
MV-1000 Major Dimensions	9-10	Troubleshooting Guide	24
SM-1000 Component Identification	11	Hazardous Locations / ATEX/IECEX – Explosive Atmosphere Installations	25-26
SM-1000 Speed/Torque Curves	12	Notes	27
SM-1000 Major Dimensions	13-15		
SM-1000 Optional Merla Valve Mounting	16		
LA-1000 Component Identification	17		
LA-1000 Speed/Thrust Curve	17		
LA-1000 Major Dimensions	18		
VA-1000 Component Identification	19		

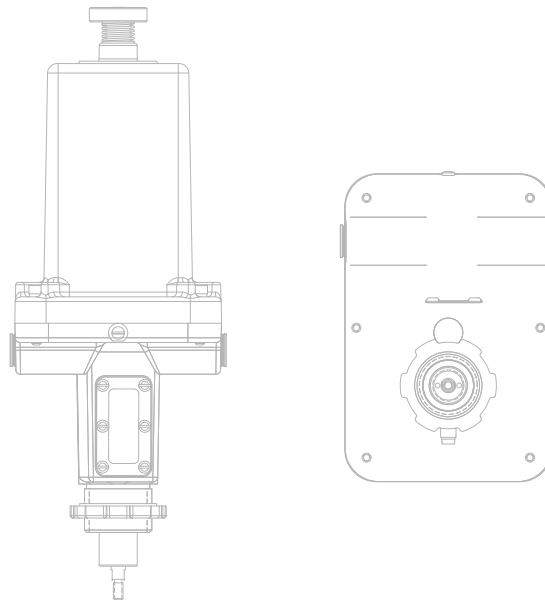

THIS MANUAL CONTAINS IMPORTANT SAFETY INFORMATION. PLEASE ENSURE IT IS THOROUGHLY READ AND UNDERSTOOD BEFORE INSTALLING, OPERATING OR MAINTAINING THE EQUIPMENT.

Introduction

Rotork Process Controls designs, manufactures, and tests its products to meet many national and international standards. For these products to operate within their normal specifications, they must be properly installed and maintained.

The following instructions must be followed and integrated with your safety program when installing and using RPC products:

- Read and save all instructions prior to installing, operating and servicing this product.
- If you don't understand any of the instructions, contact Rotork Process Controls for clarification.
- Follow all warnings, cautions and instructions marked on, and supplied with, the product.
- Inform and educate personnel in the proper installation, operation and maintenance of the product.
- Install equipment as specified in Rotork Process Controls installation instructions and per applicable local and national codes. Connect all products to the proper electrical sources.
- To ensure proper performance, use qualified personnel to install, operate, update and maintain the unit.
- When replacement parts are required, ensure that the qualified service technician uses replacement parts specified by Rotork Process Controls. Substitutions may result in fire, electrical shock, other hazards, or improper equipment operation.
- Keep all product protective covers in place (except when installing, or when maintenance is being performed by qualified personnel), to prevent electrical shock, personal injury or actuator damage.
- Operation of actuator in an inappropriate fashion may cause harm or damage to unit or other equipment surroundings.

DUE TO WIDE VARIATIONS IN THE TERMINAL NUMBERING OF ACTUATOR PRODUCTS, ACTUAL WIRING OF THIS DEVICE SHOULD FOLLOW THE DRAWING SUPPLIED WITH THE UNIT.



General Information

WARNING

Before installing the actuator, make sure that it is suitable for the intended application. If you are unsure of the suitability of this equipment for your installation, consult Rotork Process Controls prior to proceeding.

WARNING - SHOCK HAZARD

Installation and servicing must be performed only by qualified personnel.

WARNING ELECTROSTATIC DISCHARGE

This electronic control is static-sensitive. To protect the internal components from damage, never touch the printed circuit cards without using electrostatic discharge (ESD) control procedures. LA units must only be cleaned with a damp cloth.

RECEIVING / INSPECTION

Carefully inspect for shipping damage. Damage to the shipping carton is usually a good indication that it has received rough handling. Report all damage immediately to the freight carrier and Rotork Process Controls, Inc.

Unpack the product and information packet—taking care to save the shipping carton and any packing material should return be necessary. Verify that the items on the packing list or bill of lading agree with your own.

STORAGE

If the product will not be installed immediately, it should be stored in a clean, dry area where the ambient temperature is -40 to 150 °F (-40 to 65 °C). The actuator should be stored in a non-corrosive environment. The actuator is not sealed to NEMA 4 until the conduit entries are properly connected.

EQUIPMENT RETURN

A Returned Goods authorization (RG) number is required to return any equipment for repair. This must be obtained from Rotork Process Controls. (Telephone: 414/461-9200) The equipment must be shipped, freight prepaid, to the following address after the RG number is issued:

Rotork Process Controls, Inc.
5607 West Douglas Avenue
Milwaukee, Wisconsin 53218
Attn: Service Department

To facilitate quick return and handling of your equipment, include:

1. RG Number on outside of box
2. Your Company Name, Contact Name, Phone/Fax
3. Address
4. Repair Purchase Order Number
5. Brief description of the problem

NOTE: FOR HAZARDOUS LOCATION INSTALLATIONS, PLEASE REFER TO PAGES 25-26.

General Information

IDENTIFICATION LABEL

An identification label is attached to each actuator cover. When ordering parts, requesting information or service assistance, provide all of the label information.

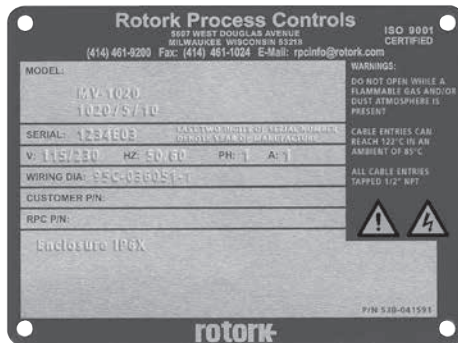

MODEL NUMBER: MV1020
 Actuator Series
 SERIAL NUMBER: 1234 E 03
 Sequential Number Year Built
 Month Built

GENERAL ACTUATOR DESCRIPTION

The 1000 Series are full-featured actuators with the capability to accept analog control signals. The design provides smooth, highly accurate positioning, with positive position-lock when not in motion. These rugged actuators may be mounted in any position and will withstand the most adverse environmental conditions.

A stepper motor produces torque, which is transmitted to the output shaft through a gear or drive screw arrangement. This allows the low torque, high speed motor output to be converted to high torque, low speed for actuator output shaft motion. The built-in servo drive amplifier controls the stepper motor's speed and direction. It also controls actuator end limits, motor torque, deadband and 4-20 mA transmitter.

- **Signal Conversion Module Option.** This option is used to accept up to four actuator open collector limit switch inputs and convert them to four form C relay output contacts. The module is furnished in one enclosure, for close-coupled mounting to the actuator.
- **Gearbox Option. (SM-1020 only)** The gearbox is factory installed to the SM-1020 output shaft to increase torque output.
- **Battery Backup Option. (4-20 mA only)** This external option provides battery backup power to the actuator along with a generated 4-20 mA command signal. When AC power is lost, the potentiometer adjustable command signal positions the actuator. After completing the positioning cycle, the battery unit enters a power conserving cycle to extend available power. When AC power is restored, the circuitry resets to automatic control. There is enough reserve power to position the actuator multiple times without a charge period. A fully discharged battery will take 12-16 hours to recharge.

A battery OK, open transistor, low-level logic output signal is provided to indicate when battery voltage has fallen below operating levels.

- **Incremental Control Option.** This option allows switched AC or DC line power to position the actuator.

ABBREVIATIONS USED IN THIS MANUAL

A	Ampere
AC	Alternating Current
°C	Degrees Celsius
CW	Clockwise
ACW	Anti-clockwise
CCW	Counter-clockwise
DC	Direct Current
°F	Degrees Fahrenheit
G	Earth Ground
Hz	Hertz
in. lbs	Inch Pounds
kg	Kilogram
L	Line (power supply)
lbs	Pounds Force
LVDT	Linear Variable Differential Transformer
mA	Milliamp
mfd	Microfarad
mm	Millimeters
N	Newton (force)
NEMA	National Electrical Manufacturing Association
Nm	Newton Meter
NPT	National Pipe Thread
PCB	Printed Circuit Board
PH	Phase
PL	Position Limit switch
RPM	Revolutions per Minute
SEC	Second
SPDT	Single Pole Double Throw
TL	Torque Limit Switch
V	Volts
VA	Volt Amps
VAC	Volts AC
VDC	Volts DC
VFD	Vacuum Fluorescent Display
VR	Variable Resistance
W	Watt

WARRANTY INFORMATION

Warranty: Subject to the following, Rotork Process Controls expressly warrants the products manufactured by it as meeting the applicable Rotork Process Controls product specifications and that such products are free from defects in material and workmanship for a period of one (1) year from the date of delivery. The foregoing is the sole and exclusive warranty made by Rotork Process Controls with respect to the products. Rotork Process Controls makes no other warranties, either express or implied (including, without limitation, warranties as to merchantability or fitness for a particular purpose). The purchaser retains responsibility for the application and functional adequacy of the offering. See Rotork Process Controls's General Conditions of Sale - Product, for complete warranty information.

Specifications

- **Standard Line Voltage:**
24/120/240 VAC, $\pm 10\%$, 50/60 Hz, 0.3/0.15 A (Slide switch select). *Supply voltage fluctuations up to 10% of the nominal voltage.*
- **Optional Line Voltage:**
SM-1015, MV-1010, VA-1010 - 24-36 VDC,
SM-1020, LA-1020, MV-1020, VA-1020 - 12-36 VDC,
SM-1020, LA-1020, MV-1020, VA-1020 - 24-36 VDC
- **Power:**
SM-1015, LA-1010, MV-1005, MV-1010, VA-1010 - 18 VA,
SM-1020, LA-1020, MV-1020, VA-1020 - 36 VA.
- **Command Signal Inputs:** 4-20 mA, 4-12 mA, 12-20 mA
0-5 VDC, 0-10 VDC. Incremental contact closures.
- **Position Feedback Signal:** Isolated 4-20 mA.
- **Field Wiring Terminations:** Plugable terminal block, wire size range 26-14 AWG.
- **Command Signal Monitor:** (current command only).
The 1000 series loss-of-signal circuitry monitors the command signal input. If the command signal drops below 3.2 mA or above 20.7 mA, the actuator will either lock in place or run to a preset position (user selectable).
- **Limit Signals:**
 - Internal:** Part of servo control
 - External:** Open transistor low level logic outputs, adjustable over stroke range.
 - Rating:** 40 VDC at 40 mA maximum. For customer use, not part of servo control.
- **Current Limit:** Automatic adjustment of the motor current limit (internal to servo control).
- **Stroke:** Up to 1.38 in. (35 mm) Infinitely adjustable within range.
- **Speed/Torque:** See speed/force curves.
- **Output Shaft Motion:** All models can go either direction on an increasing command signal. This is determined by the ZERO and SPAN settings.
- **Rotation:** SM models without gearbox: 90° to 2 turns or 2 to 20 turns. Infinitely adjustable within range.
SM models with gearbox: 30° to 153° or 150° to 4.25 turns. Infinitely adjustable within range.
- **Stroke:**
 - LA models:** 0.75 - 18 in. (19 - 457 mm)
 - MV models:** 0.09 - 1.38 in. (2.4 - 35 mm)
 - VA models:** 0.34 - 1.5 in. (9 - 38 mm)
 - All models infinitely adjustable within range.
- **Weight:** (Not including devices mounted to actuator)
 - SM-1015:** 12 lbs. (5.4 kg)
 - SM-1020:** 16 lbs. (7.3 kg)
 - SM-1020 with gearbox:** 19 lbs. (8.6 kg)
 - LA-1020:** 16 lbs. (7.3 kg)
 - MV-1005:** 12 lbs. (5.4 kg)
 - MV-1010:** 12 lbs. (5.4 kg)
 - MV-1020:** 16 lbs. (7.3 kg)
 - VA-1010:** 20 lbs. (9.1 kg)
 - VA-1020:** 24 lbs. (10.9 kg).
- **Conduit Entry:** ½ NPT.
- **Handwheel:** Push to engage, spring return on release. *(Not available with MV-1005).*
- **Temperature Limits:** -40 to 150 °F (-40 to 65 °C).
- **Altitude:** Up to 3,280 ft. (1000 m) above mean sea level.
- **Pollution Degree:** 2
- **Installation Category:** II
- **Enclosure:** Type 4 (IP65), indoor or outdoor.
- **Duty Cycle:** Unrestricted modulating duty. (Cont. duty).
- **Position Accuracy:** 1% of full range.
- **Deadband:** Factory preset to 1%. Field adjustable.

Specifications - Optional Merla Valve Mounting

MECHANICAL

- **Stroke:** Output Torque: 125 in. lb. maximum.
- **Output Shaft Speed:** 3.3 rpm (90 seconds full stroke on 4.6 turn MERLA valve).
- **Maximum Turns:** Maximum 5 output shaft turns (Factory set at 4.6 turns).
- **Storage Temperature:** -40 to 85 °C (-40 to 185 °F) Ambient.
- **Operating Temperature:** 4 to 70 °C (39 to 158 °F).
- **Enclosure:** Gray epoxy coating over gray anodized finish. Waterproof and corrosion resistant finish, aluminum or stainless steel external parts. Local manual operating handwheel, rotates when actuator is moving. Designed for Class 1, Div 1, Group C & D 'explosionproof' service.
- **Repeatability:** 1% of full span.
- **Positioning Accuracy:** 1% of full span.
- **Other:**
 - Output shaft locks-in-place on loss of power
 - Output shaft locks-in-place on loss of command signal (command signal at zero mA)
 - All hardware is stainless steel or aluminum.

VALVE MOUNT

- **Valve:** Mount supplied for MERLA FCV valve.
- **Material:** Machined from extruded aluminum and anodized.
- **Finish:** Gray epoxy coating over gray anodized finish.
- **Hardware:** Stainless steel. All needed hardware supplied.
- **Torque Required:** 125 in. lb. per customer spec. and MERLA catalog.
- **Full Stroke:** 4.6 turns (½-13 stem thread) as measured.
- **Stem Rise:** 0.35 inch as measured.

Physical Installation

ACTUATOR CHARACTERISTICS

- The actuator output shaft is made of stainless steel and the housing is aluminum.
- **Vibration Limits:** 4-15 Hz @ .5 ± .1 mm amplitude max.
- **Enclosure Materials:** The actuators are manufactured from alluminum alloy with stainless steel shafts, oilite bronze bushes and carbon steel fasteners. All external seals are manufactured from Nitrile which are suitable for use in an ambient temperature range of -40 to +85 °C. The user must ensure that the operating environment and any materials surrounding the actuator cannot lead to a reduction in the safe use of, or the protection afforded by, the actuator. Where appropriate the user must ensure the actuator is suitable protected against its operating environment.

SPARE PARTS

- Spare parts and spare parts lists can be obtained by contacting the Rotork Process Controls Service Department.

MAINTENANCE

- Rotork Process Controls actuators are maintenance free. It is recommended that you remove the cover and visually inspect the actuator for any irregularities on an annual basis.
- Maintenance must be performed only by qualified personnel. Voltages hazardous to your health are applied to these actuators. De-energize all sources of power before removing actuator cover. Failure to follow these precautions may result in serious injury or death.
- Lubrication: The gearing is permanently lubricated. Re-lubrication is only required during repairs to the power gearing. The bronze bushings are lubricated with a few drops of SAE-10 or 20 NON-DETERGENT oil. Re-lubricate when repairs are made.

ELECTRICAL SUPPLY REQUIREMENTS

- An overcurrent protective device is required for the supply power. Size the overcurrent device per requirements of actuator for 125% of maximum rated load.
- Disconnect for the supply power is to be supplied by the customer.
- Wire conductor type and size should match Rotork Process Controls requirements, wiring diagrams and follow local codes.

MV-1000 Series Component Identification

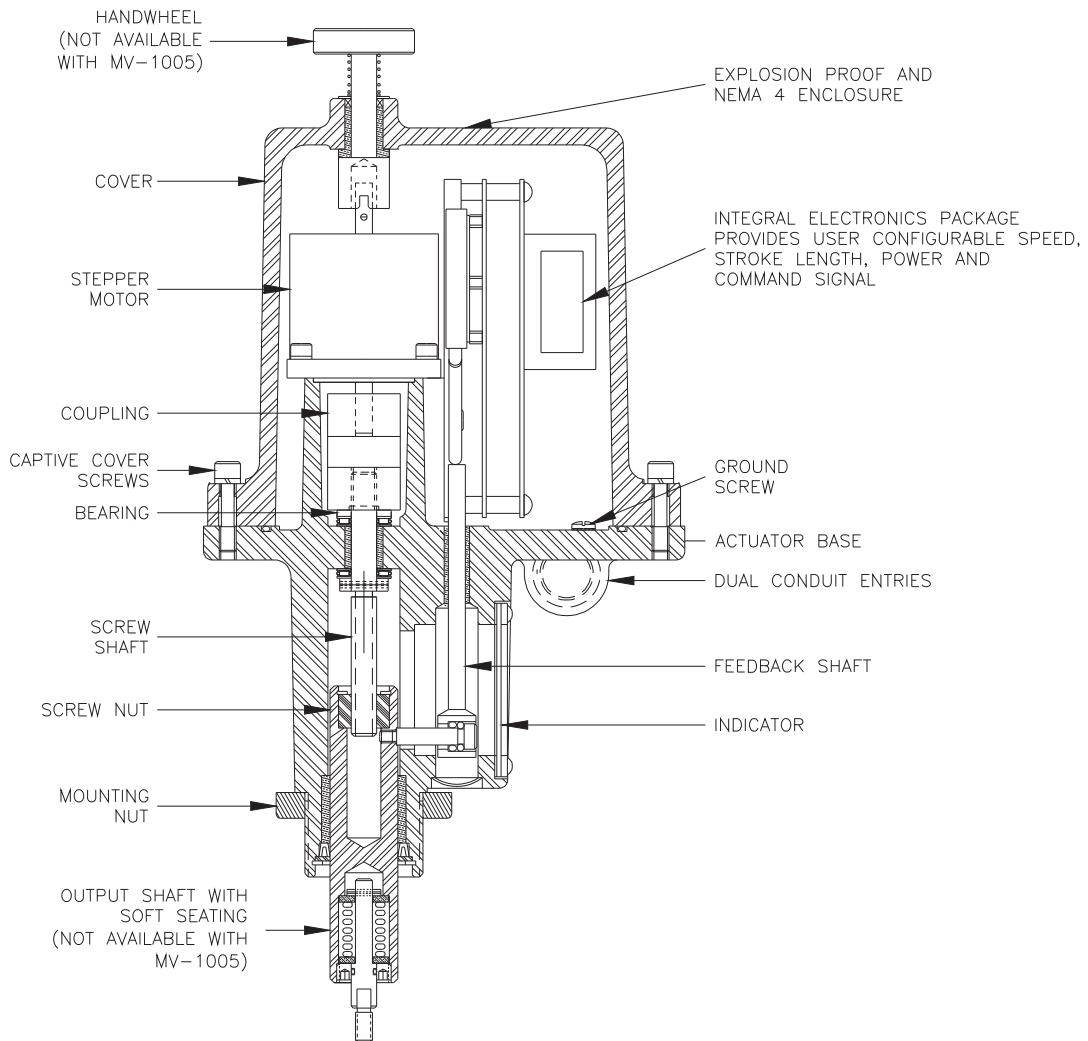

MV-1000 Series Speed/Thrust Curve

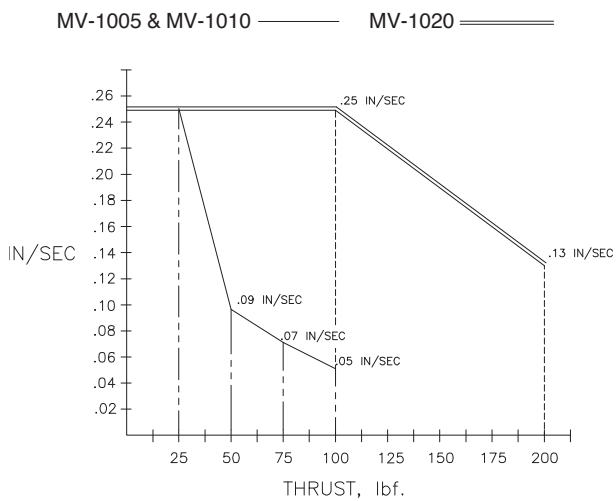

To calculate shift time (total stroke), use this formula:

$$\text{Shift time (sec.)} = \frac{\text{Total stroke in inches}}{\text{Stroke rate of actuator in in./sec.}}$$

Example: 1.25 inch stroke, 150 lbf thrust $\frac{1.25}{0.19} = 6.6 \text{ sec.}$

MV-1000 Series Major Dimensions - Cast Yoke Base

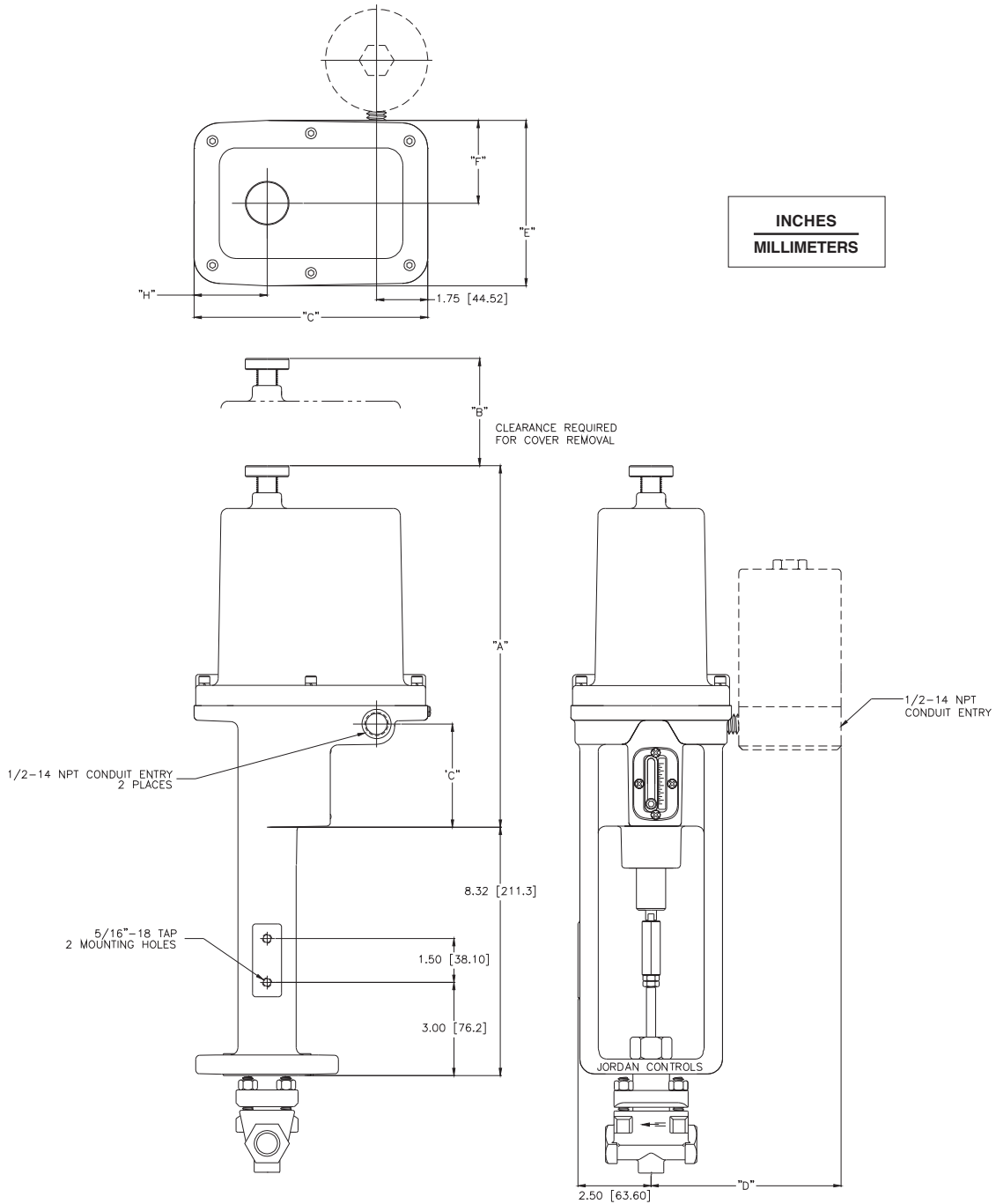

	A	B	C	D	E	F	G	H
MV-1010	11.43 (290.3)	5.25 (133.4)	3.40 (86.4)	6.52 (165.6)	5.39 (136.9)	2.69 (68.3)	7.12 (180.8)	2.37 (60.2)
MV-1020	12.37 (314.2)	6.13 (155.7)	3.53 (89.7)	6.64 (168.7)	5.66 (143.8)	2.83 (71.9)	8.00 (203.2)	2.50 (63.5)

These dimensions are subject to change without notice and should not be used for preparation of drawings or fabrication of installation mounting. For current installation manuals and other product information, see www.rotork.com

SM-1000 Series Component Identification

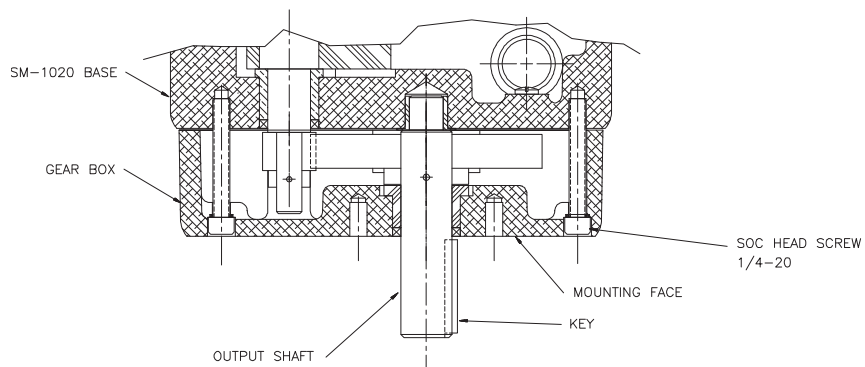
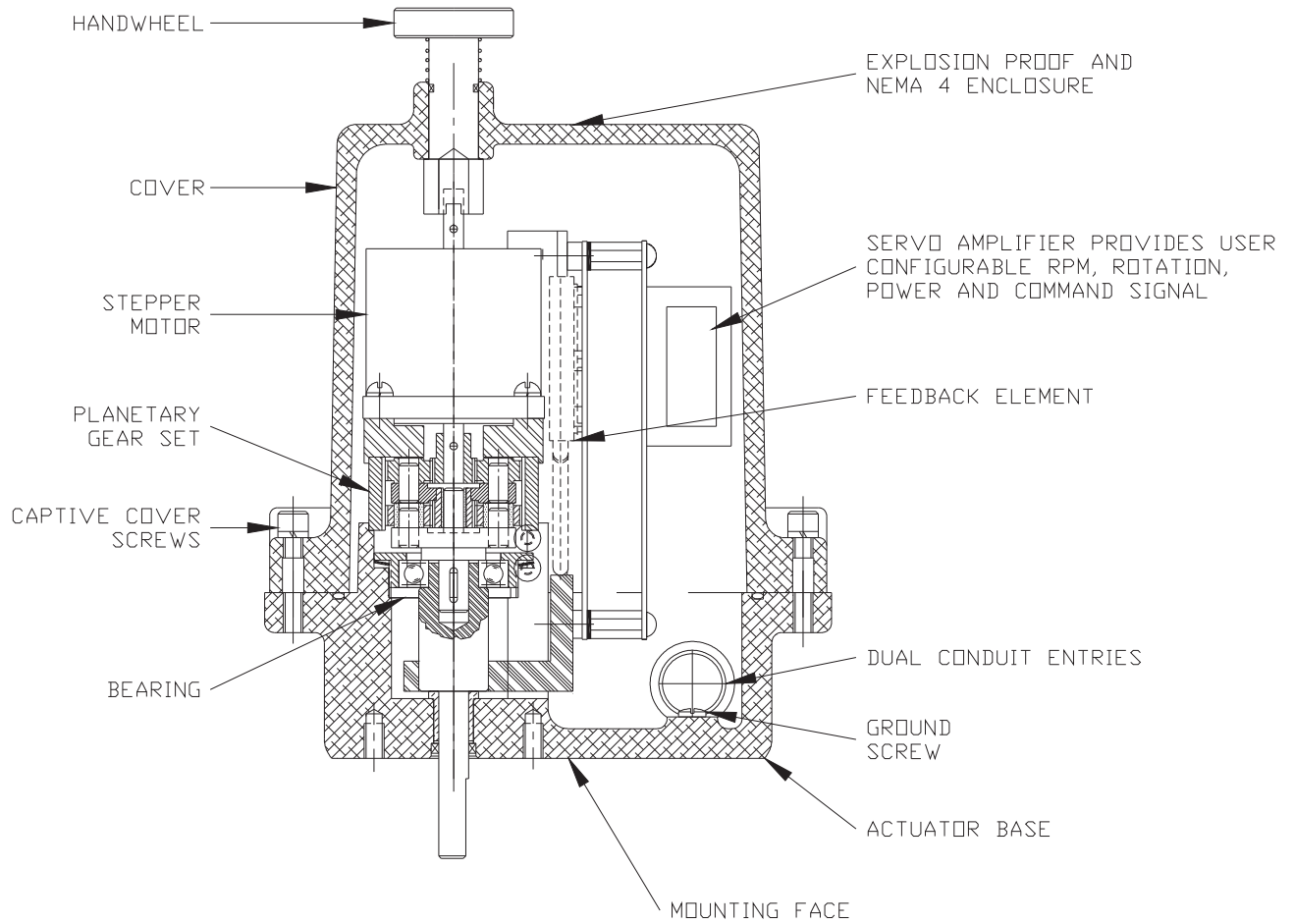

SM-1000 Series Speed/Torque Curves

$$\text{Shift time (sec.)} = \frac{\text{Maximum revolutions for total range} \times 60}{\text{Revolutions per minute}}$$

Example: 90° rotation at 1 rpm,
80 in. lbs. torque

$$\frac{0.25 \times 60}{1} = 15 \text{ sec.}$$

SM-1015 ————— SM-1020 =====

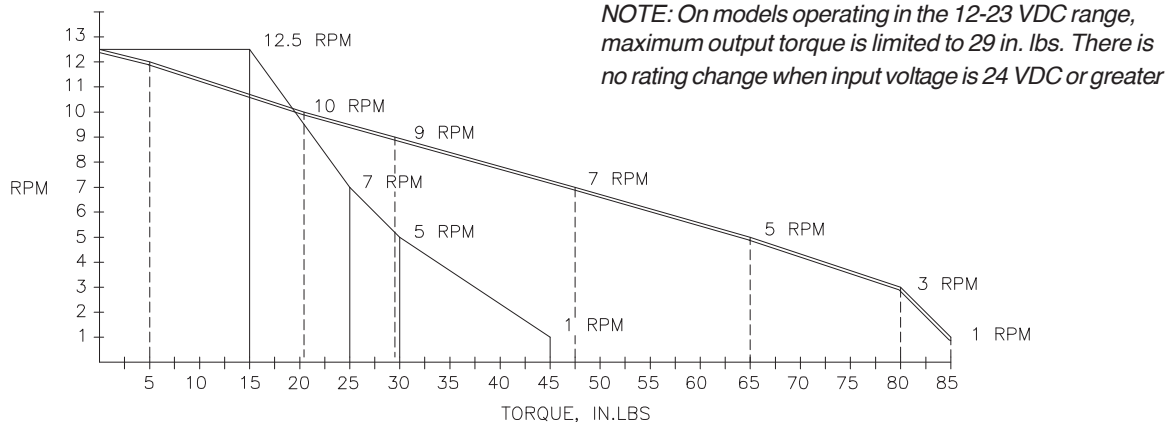

SM-1020 With Gearbox

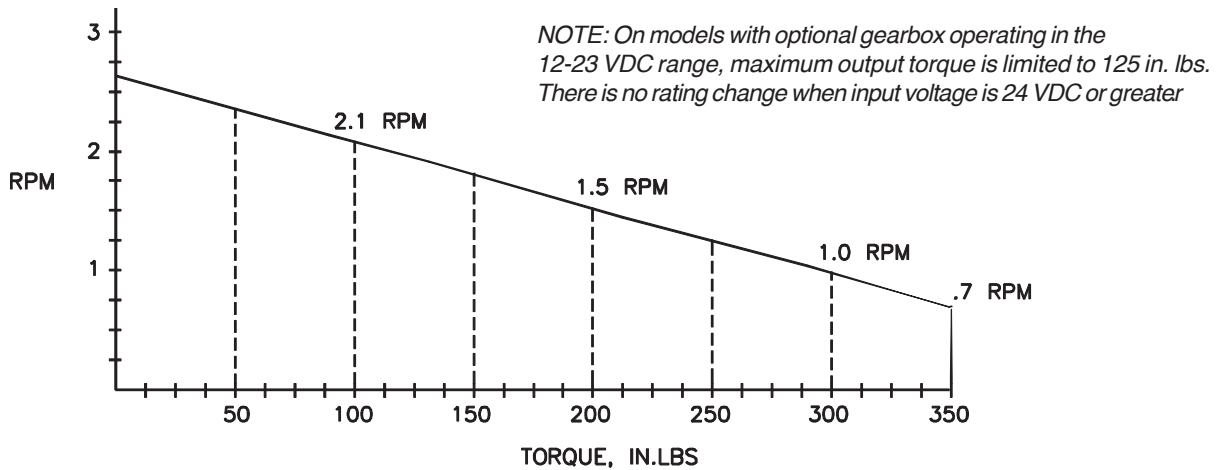

SM-1000 Series Major Dimensions - SM1015 & SM1020

INCHES
(MILLIMETERS)

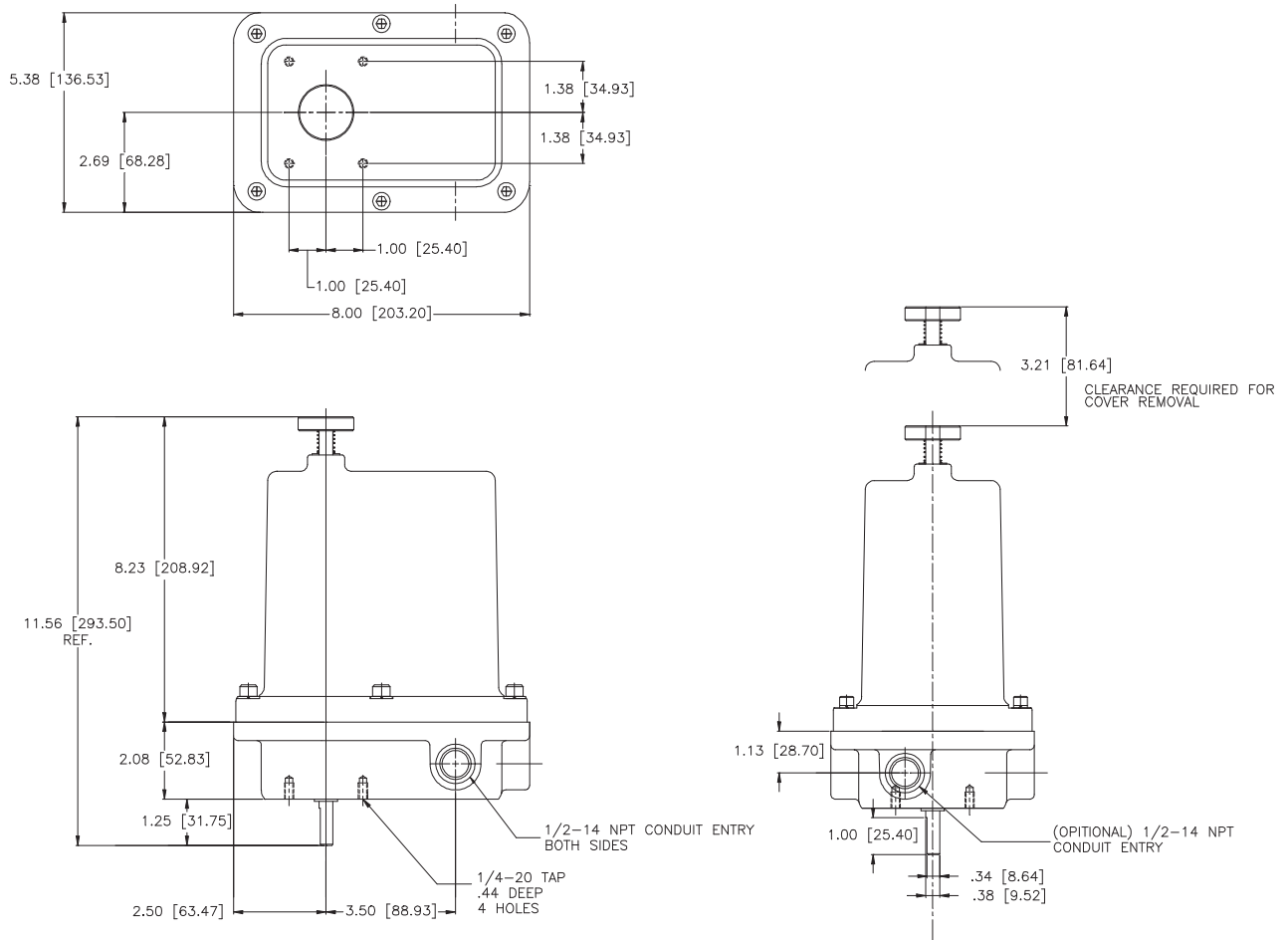

These dimensions are subject to change without notice and should not be used for preparation of drawings or fabrication of installation mounting. For current installation manuals and other product information, see www.rotork.com

SM-1000 Major Dimensions - SM-1020 with Gearbox

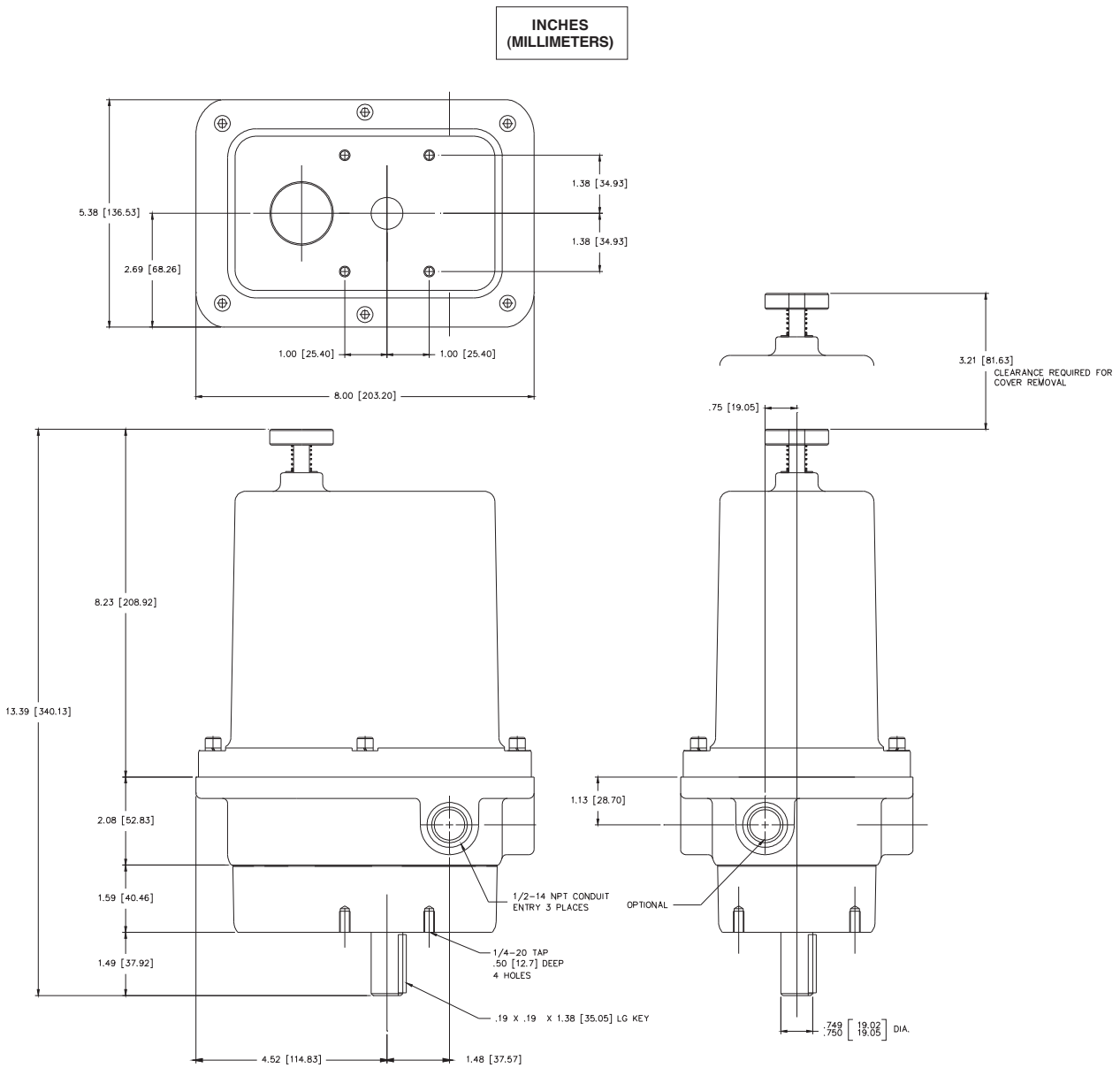

These dimensions are subject to change without notice and should not be used for preparation of drawings or fabrication of installation mounting. For current installation manuals and other product information, see www.rotork.com

SM-1000 Major Dimensions - Optional Group B Enclosure

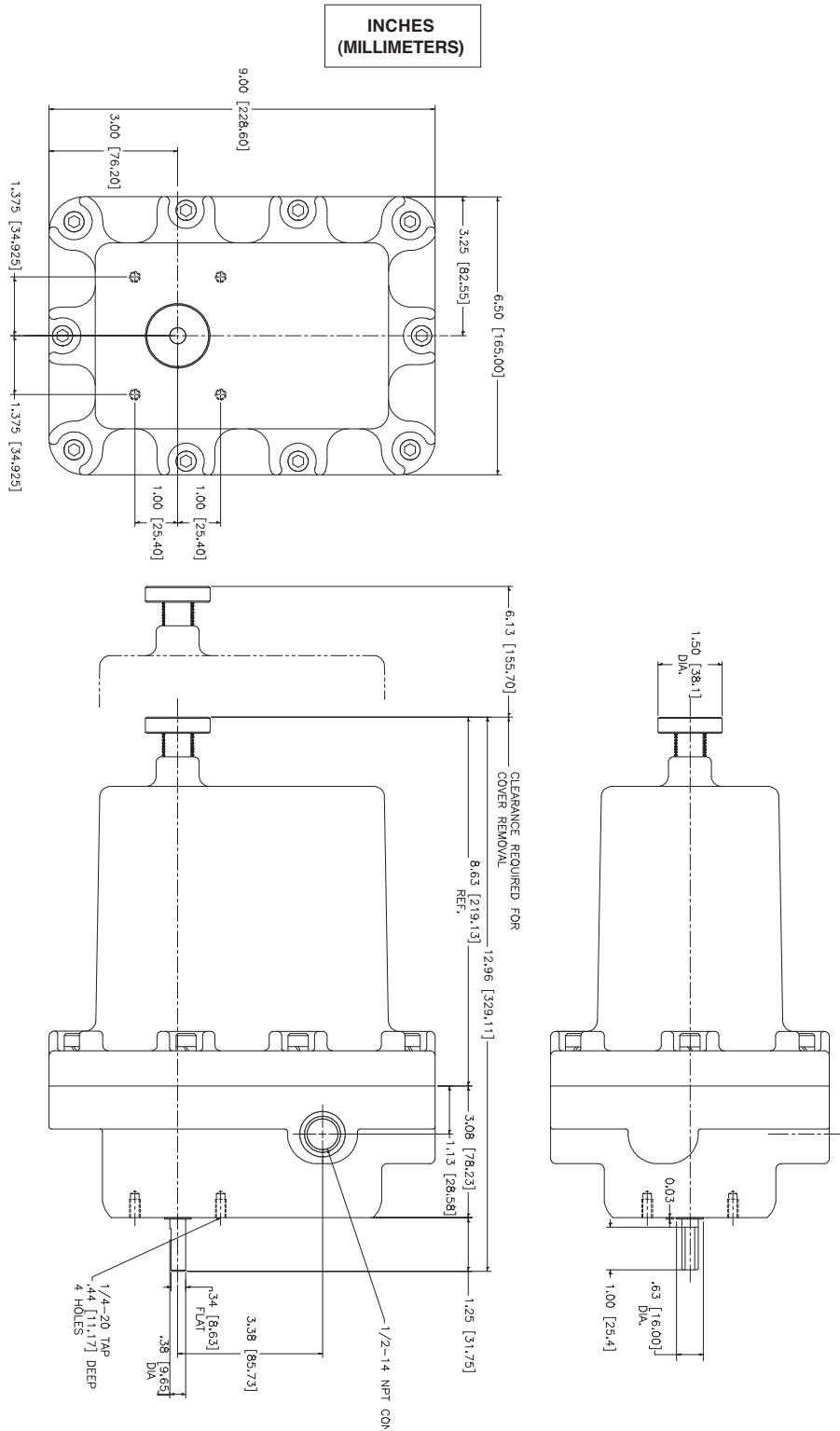

These dimensions are subject to change without notice and should not be used for preparation of drawings or fabrication of installation mounting. For current installation manuals and other product information, see www.rotork.com

SM-1000 Major Dimensions - Optional Merla Valve Mounting

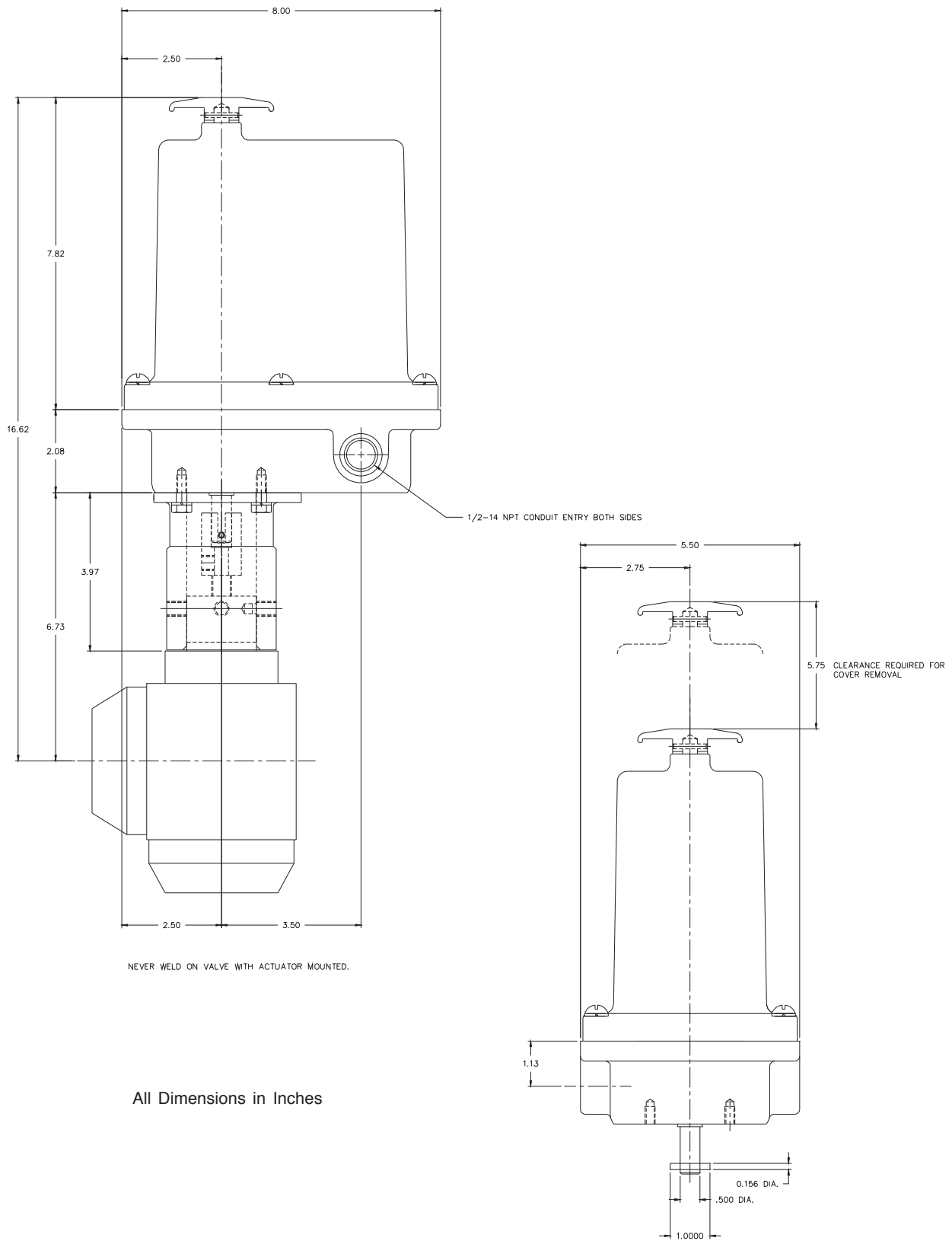

All Dimensions in Inches

LA-1000 Series Component Identification

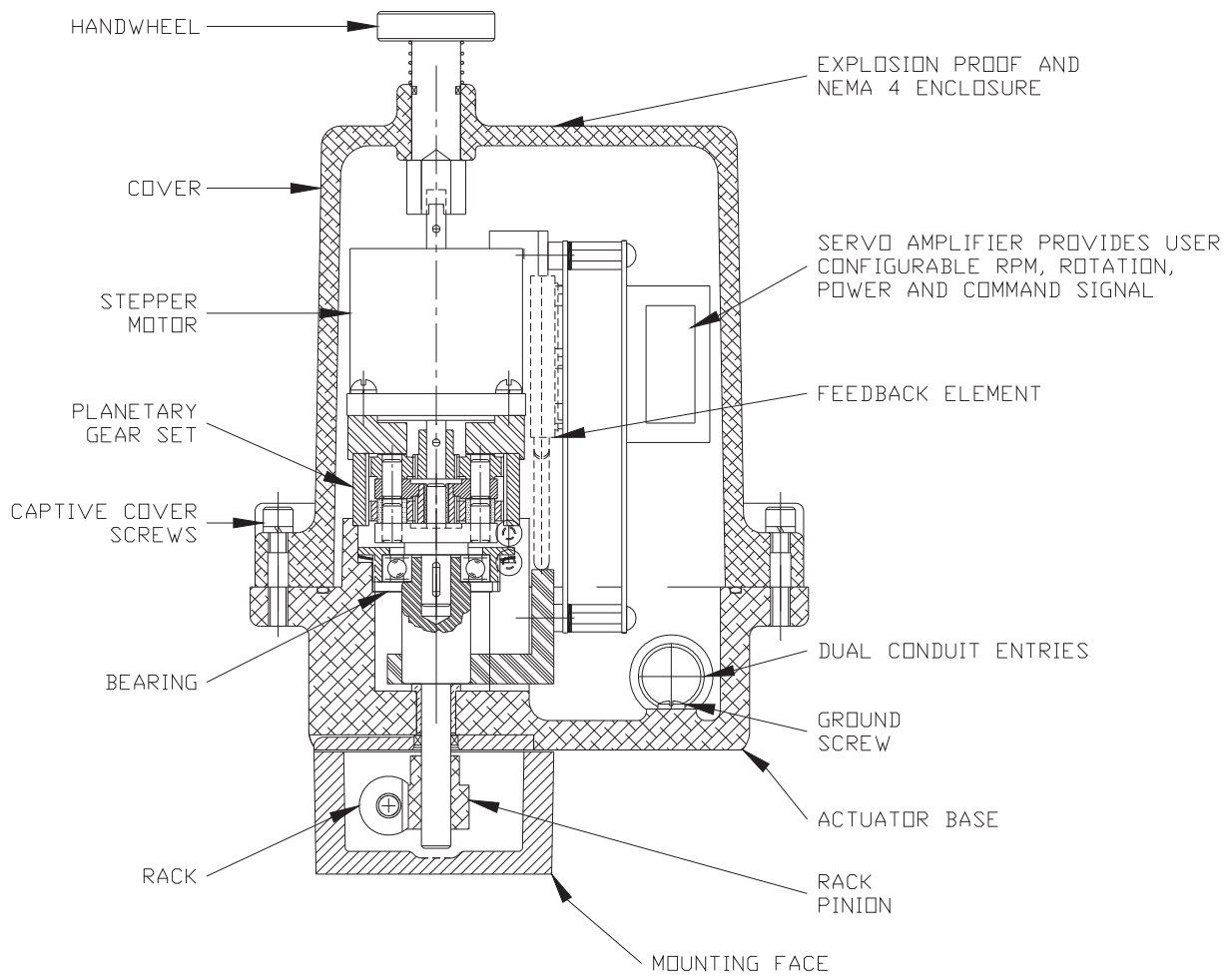

LA-1000 Series Speed/Thrust Curve

To calculate stroke time of LA-1020 with speed/thrust of 30/50, use:

$$\text{Stroke time (sec.)} = \frac{\text{Total stroke in inches (mm)} \times 60}{\text{Speed of actuator in inches/min. (mm/min.)}}$$

Example:
 6 inch stroke = $\frac{6 \times 60}{30} = 12 \text{ sec.}$

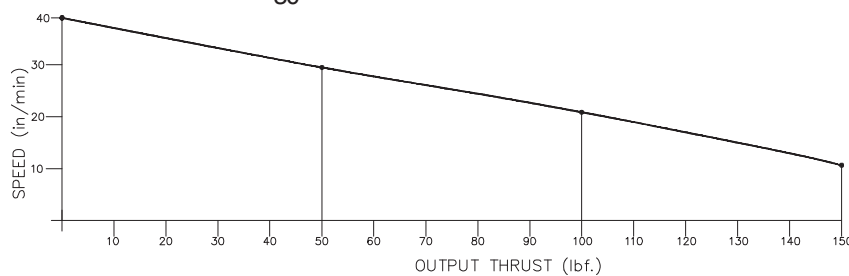

LA-1000 Major Dimensions

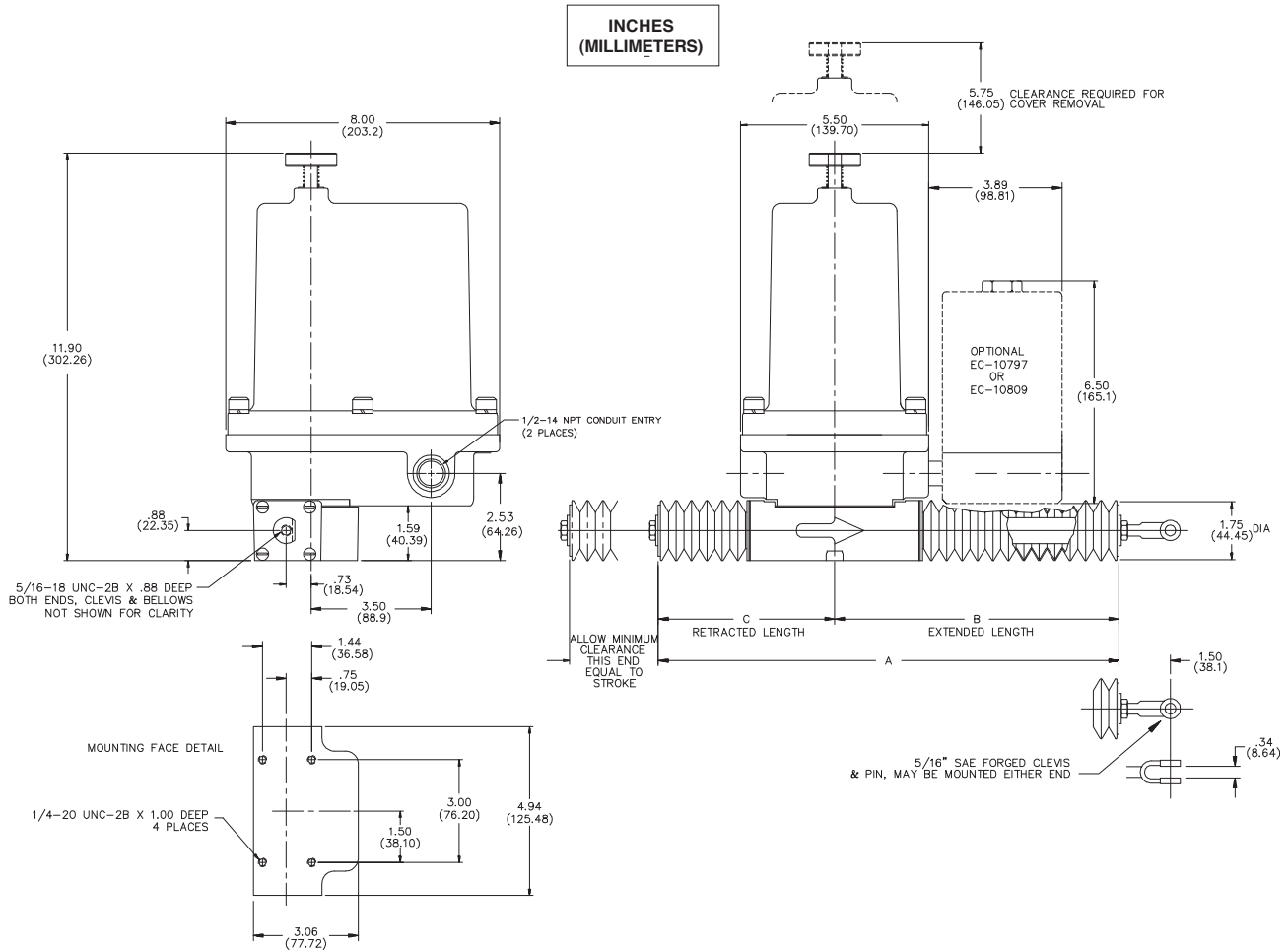

STROKE	A	B	C
0.75-3 (19-76)	12.38 (314)	7.69 (195)	4.69 (119)
3-6 (76-152)	17.38 (441)	11.69 (297)	5.69 (145)
6-9 (153-229)	22.38 (568)	15.69 (399)	6.69 (170)
9-12 (229-305)	27.38 (695)	19.69 (500)	7.69 (195)
12-15 (305-381)	32.38 (882)	23.69 (602)	8.69 (221)
15-18 (381-457)	42.38 (1076)	31.69 (805)	10.69 (272)

These dimensions are subject to change without notice and should not be used for preparation of drawings or fabrication of installation mounting. For current installation manuals and other product information, see www.rotork.com

VA-1000 Series Component Identification

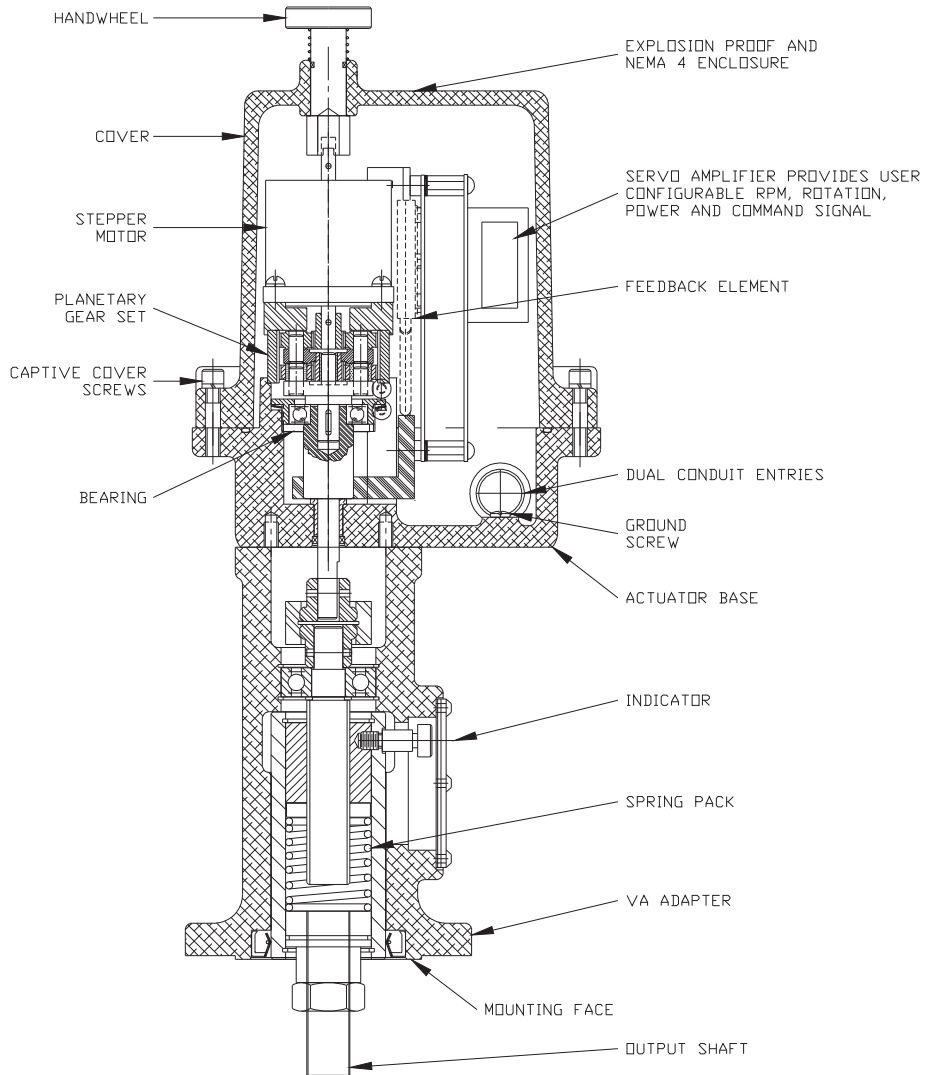

VA-1000 Series Speed/Thrust Curve

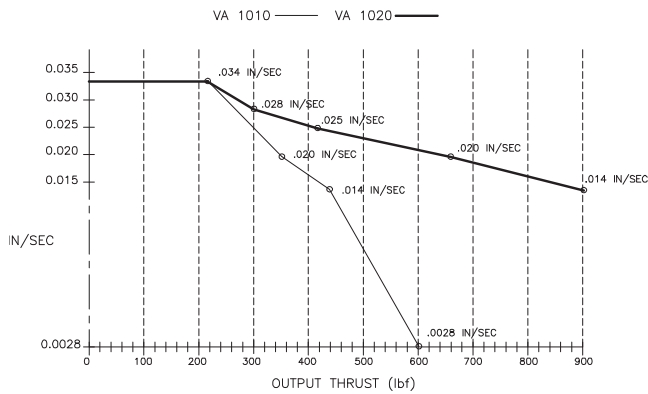

To calculate shift time (total stroke), use this formula:

$$\text{Shift time (sec.)} = \frac{\text{Total stroke in inches}}{\text{Stroke rate of actuator in in./sec.}}$$

Example: 0.75 inch stroke, 400 lbf thrust $\frac{0.75}{0.025} = 30 \text{ sec. (VA-1020)}$

$$\frac{0.75}{0.017} = 44.1 \text{ sec. (VA-1010)}$$

NOTE: On models operating in the 12-23 VDC range, maximum output thrust is limited to 423 lbf. There is no rating change when input voltage is 24 VDC or greater

VA-1000 Major Dimensions

INCHES
(MILLIMETERS)

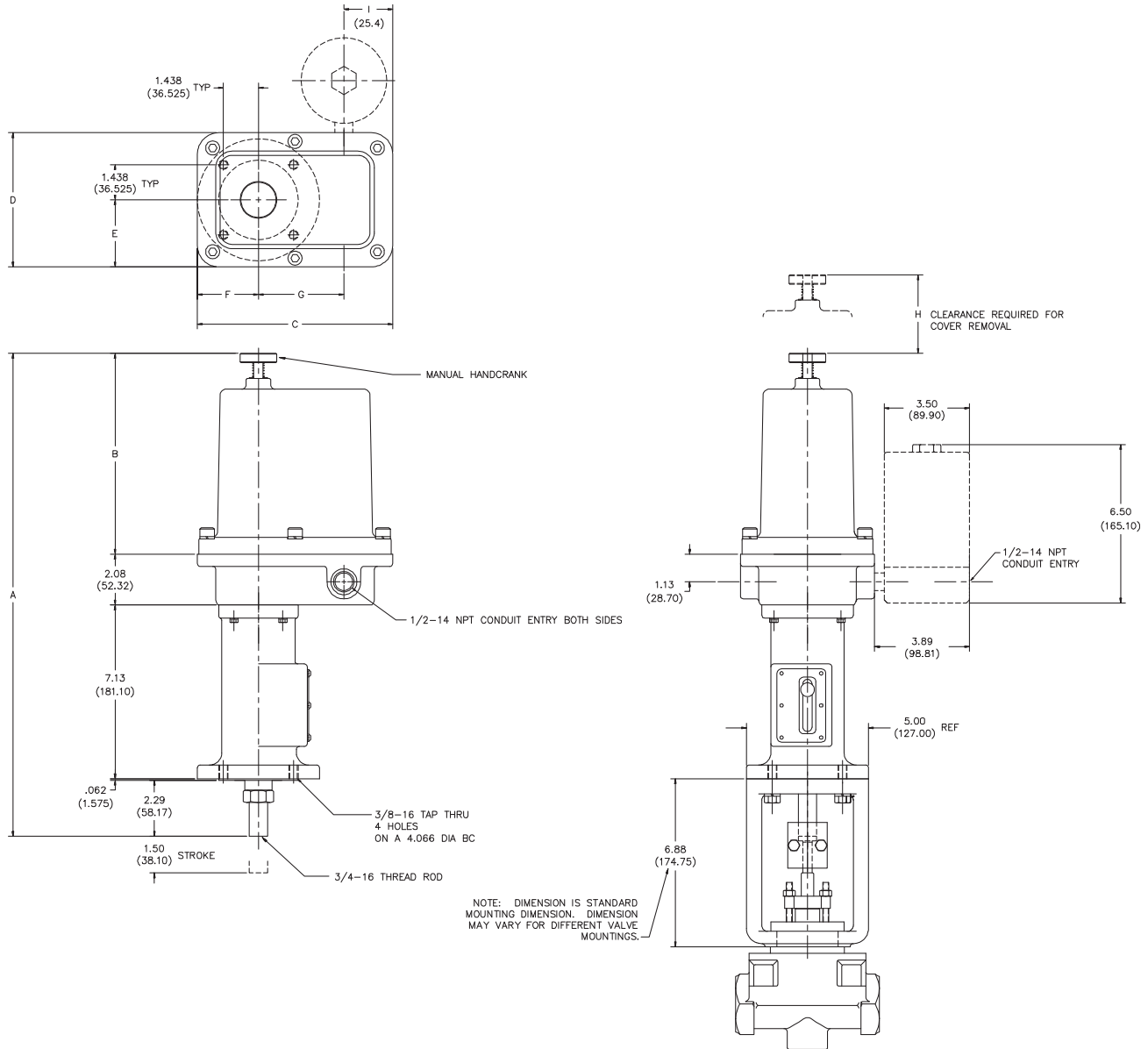

	A	B	C	D	E	F	G	H	I
VA-1015	18.9 (480.06)	7.35 (186.69)	7.13 (181.1)	5.25 (133.35)	2.63 (66.8)	2.38 (60.45)	3.00 (76.20)	5.25 (33.35)	1.75 (44.45)
VA-1020	21.2 (541.02)	8.25 (209.55)	8.00 (203.2)	5.5 (139.7)	2.75 (69.85)	2.5 (63.5)	3.5 (88.9)	5.75 (146.05)	2.00 (50.8)

These dimensions are subject to change without notice and should not be used for preparation of drawings or fabrication of installation mounting. For current installation manuals and other product information, see www.rotork.com

Installation Wiring

GENERAL

All wiring should be done in accordance with prevailing codes by qualified personnel.

Typical wiring diagrams are shown on page 8. *Actual wiring should follow the print supplied with the actuator.*

Fusing must be installed in line power, and should be of the slow blow type. Recommend 1 amp for AC input models and 5 amp for DC input models.

Wiring should be routed to the actuator through one of the two 1/2 inch conduit openings. Generally, one conduit will contain input power and earth ground wires. The other conduit would then contain low level input and output signal wiring.

It is recommended that all low level signal wiring be a shielded type with the shield grounded at source common.

After installation, it is recommended that all conduits be sealed to prevent water damage.

Strip 0.22 inch (5.6mm) of insulation from the wire and insert this bare end into the appropriate terminal location, utilizing an insertion tool or a small screwdriver.

Maximum recommended wire size is 14 AWG, and minimum is 26 AWG.

WIRING TO TB1

Input power terminates at TB1. For ac models, terminal 1 is line, and terminal 2 is neutral. For DC models, terminal 1 is positive (+), and terminal 2 is negative (-). Terminal strip tabs are pressed down to insert wires.

WIRING TO TB2

LS1 and LS2 may be used as optional end of travel limit switches. The incoming power supply earth ground should be securely connected to the green ground screw located inside the actuator base between the two conduit entries.

WIRING TO TB3

If LS1, LS2, LS3 and LS4 are used as auxiliary position limit switches, connection is to terminals 1 through terminal 4. Maximum voltage is 40 VDC and maximum current is 40 mA.

4-20 mA position feedback signal wires connect to terminals 9 (+) and 10 (-).

Increasing command signal will result in an increasing position feedback signal. Operation of the transmitter requires an external dc power supply in the range of 12 VDC (minimum) to 36 VDC (maximum) and a load connected in series with one lead from the power supply.

$\frac{\text{Power Supply Voltage} - 8 \text{ VDC}}{0.020\text{A}} \quad P = \text{load resistance}$ <p><i>Example:</i></p> $\frac{24 \text{ VDC} - 8 \text{ VDC}}{0.020\text{A}} = 800 \text{ ohms maximum load}$
--

WIRING TO TB4

This terminal strip is only used on models with 3W option (3 wire, 120 or 240 VAC incremental control), and is located near the top of the PC board assembly.

Start-up Information

START UP FOR LOW LEVEL CURRENT OR VOLTAGE COMMAND SIGNALS

1. **Power.** Before applying AC or DC power to TB1 of the upper power supply board, as the appropriate model requires, set slide switch to the correct voltage. For DC input, slide switch position is not important.
2. **Command Switch.** For 4-20 mA current command place dipswitch 3 in the ON (down) position. For voltage command place dipswitch 3 in the ON (down) position for 0-5 VDC or OFF (up) position for 0-10 VDC. Split range command may be enabled for a current command by placing dipswitch 4 in the ON (down) position. To select the range of the actuator place dipswitch 5 ON (down) for 12-20 mA or OFF (up) for 4-12 mA.
3. **Model Switch.** For SM, VA, and LA units place dipswitch 6 in the ON (down) position. For MV units place dipswitch 6 in the OFF (up) position.
4. **Auto Switch.** Place DIP Switch 1 to ON (Down) to place actuator in AUTO mode.
5. **Setpoints.** These are the end of travel extremes corresponding to the actuator output shaft positions for low (4 mA for current command input or 0 VDC for voltage command input); and high (20 mA for current command input, 5 VDC for 0-5 VDC voltage command input or 10 VDC for 0-10 VDC voltage command input) command signal levels. They are set by the ZERO and SPAN push buttons and adjusting knob. All settings require the holding of a push button and the turning of the adjusting knob.
 - A. Set the command signal to lowest level, normally 4 mA. Press and hold ZERO (S1) and LOS(S5) pushbuttons until D5 is illuminated to calibrate low command value (approx. 2 seconds).
 - B. Adjust LO setpoint (ZERO) by holding ZERO push button (S1) and turning adjusting knob to move actuator output shaft to desired ZERO position. Rotating the adjusting knob CW will cause the output shaft to extend on linear units, or rotate CW on rotary units. Rotating the adjusting knob CCW will cause the output shaft to retract on linear units, or rotate CCW on rotary units. For fine adjustments, turn the adjusting knob slowly. The knob is speed sensitive, so the faster it is turned, the more displacement of the actuator will occur. The yellow (DEC) LED will illuminate while actuator is moving toward the LO setpoint. Release button.
 - C. Adjust transmitter low setting (4 mA) by pressing and holding ZERO (S1) and LOS (S5) pushbuttons until D5 is illuminated (approx. 2 seconds). While holding pushbuttons, turn adjusting knob CW to increase transmitter low setting, or CCW to decrease setting.
 - D. Set the command signal to highest level, normally 20 mA. Press and hold SPAN (S2) and LOS(S5) pushbuttons until D5 is illuminated to calibrate high command value (approx. 2 seconds).
- E. Adjust HI setpoint (SPAN) by holding SPAN push button (S2) and turning adjusting knob to move actuator output shaft to desired SPAN position. Rotating the adjusting knob CCW will cause the output shaft to retract on linear units, or rotate CCW on rotary units. For fine adjustments, turn the adjusting knob slowly. The adjusting knob is speed sensitive, so the faster it is turned, the more displacement of the actuator will occur. The green (INC) LED will illuminate while actuator is moving toward the HI setpoint. Release button.
- F. Adjust transmitter high setting (20 mA) by pressing and holding SPAN (S2) and LOS (S5) pushbuttons until D5 is illuminated (approx. 2 seconds). While holding pushbuttons, turn adjusting knob CW to increase transmitter high setting, or CCW to decrease transmitter high setting.
- G. To set up the actuator in a reverse acting fashion for linear units, set the ZERO position beyond the SPAN position, which will cause the output shaft to retract on an increasing command signal. For rotary units, set the ZERO position beyond the SPAN position, which will cause the output shaft to rotate CW on an increasing command signal. The factory setting for linear units is to extend with an increasing signal. The factory setting for rotary units is to rotate CCW with an increasing signal.
6. **Deadband.** This adjustment establishes the actuator servo sensitivity. It is factory set at 1% and should not be field adjusted. If the actuator begins to oscillate (Green and Yellow LEDs turn on and off rapidly), decrease the sensitivity by holding deadband push button (S4) and turning adjusting knob CW until oscillation stops. Release button.
7. **Speed.** Adjust Speed is preset at the factory. To adjust speed, hold the speed push button (S3) and turn the adjusting knob CW to increase or CCW to decrease actuator speed. Note that actuator force and speed are related, see speed/force curves.
8. **Loss of Signal Preset.** This adjustment establishes the position to which the actuator will travel upon a loss of command signal condition. To activate this setting, SW2 must be OFF (Up). Adjust the setting by holding the LOS push button (S5) and turning the adjusting knob to set the preset position. Turn the adjusting knob CW to extend the feedback potentiometer, and CCW to retract it.
9. **Auxiliary Limit Switches.** LS-1, LS-2, LS-3 and LS-4 are available for customer use. They are adjusted with trim pots on upper PC board, and the adjacent red LEDs indicate state.
10. **Verify all settings** by running the actuator through its travel range several times.
11. **Reset defaults.** Factory presets may be restored by depressing and holding SPEED (S3), DEADBAND (S4), and LOS (S5) until D5 is illuminated (2 seconds).

Start-up Information

START UP FOR INCREMENTAL CONTROL

1. **Power.** Before applying AC or DC power to TB1 of the upper power supply board, as the appropriate model requires, set slide switch to the correct voltage. For DC input, slide switch position is not important.
2. **Command Switch.** For 4-20 mA current command place dipswitch 3 in the ON (down) position. For voltage command place dipswitch 3 in the ON (down) position for 0-5 VDC or OFF (up) position for 0-10 VDC. Split range command may be enabled for a current command by placing dipswitch 4 in the ON (down) position. To select the range of the actuator place dipswitch 5 ON (down) for 12-20 mA or OFF (up) for 4-12 mA.
3. **Model Switch.** For SM, VA, and LA units place dipswitch 6 in the ON (down) position. For MV units place dipswitch 6 in the OFF (up) position.
4. **Two isolated, dry contact closures** are used to position the actuator. These contacts are customer supplied and may be within a remotely located controller or may be push buttons or switches used for manual control. *Do not exceed 50 feet of run length.*
5. **Place DIP Switch 1** to OFF (Up) position to place the actuator in manual mode.
 - A. Close DEC contact. The actuator will move toward the low command position, and the yellow LED will illuminate. Once low command position has been reached, actuator travel will stop.
 - B. Adjust LO setpoint (ZERO) by holding ZERO push button (S1) and turning adjusting knob to move actuator output shaft to desired position. Turn the adjusting knob CW to extend the output shaft, and CCW to retract the output shaft. Release button.
6. **Deadband.** The deadband adjustment has no influence in this mode of operation.
7. **Speed.** Speed is preset at the factory. To adjust speed, hold the speed push button (S3) and turn the adjusting knob CW to increase or CCW to decrease actuator speed. Note that actuator torque and speed are related, see speed/torque curve on page 4.
8. **Auxiliary Limit Switches.** LS-1, LS-2, LS-3 and LS-4 are available for customer use. They are adjusted with trim pots on upper PC board, and the adjacent red LEDs indicate state.
9. **Verify all settings** by running the actuator through its travel range several times.
10. **Reset defaults.** Factory presets may be restored by depressing and holding SPEED (S3), DEADBAND (S4), and LOS (S5) until D5 is illuminated (approximately 2 seconds).

LOWER PC BOARD

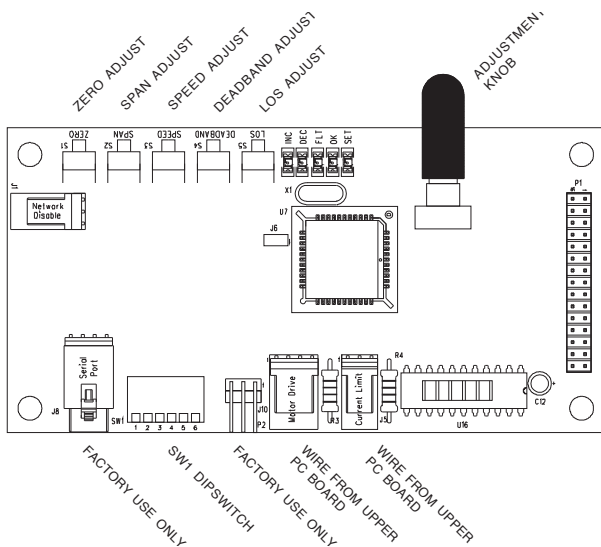

DIP SWITCH CONFIGURATIONS SW1

Switch	Switch Position	Function
1	On (down)	Auto
	Off (up)	Manual
2	On (down)	LOS- lock in place
	Off (up)	LOS- go to preset
3	On (down)	4-20 mA, 0-5 VDC command
	Off (up)	0-10 VDC command
4	On (down)	Split range enabled
	Off (up)	Split range disabled
5	On (down)	12-20 mA, if split range is enabled
	Off (up)	4-12 mA, if split range is enabled
6	On (down)	SM, VA, LA unit
	Off (up)	MV unit

Typical Wiring Diagram

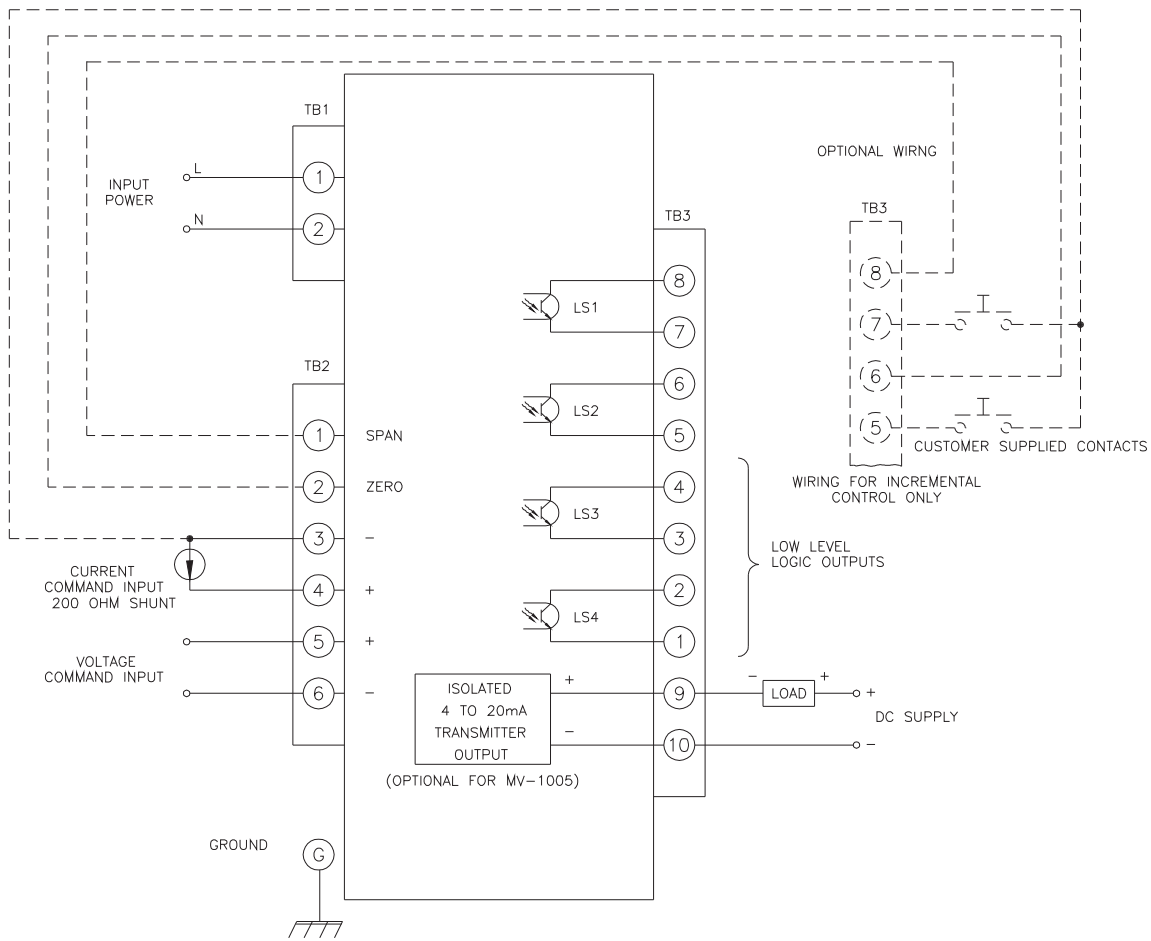

Due to wide variations in the terminal numbering of actuator products, actual wiring of this device should follow the print supplied with the unit.

Troubleshooting Guide

VISUAL TROUBLESHOOTING

For visual troubleshooting, LEDs are provided to display the status of the actuator. These are located on the opposite side of the lower board as SW1. The identification of these LEDs are shown in the table below, and are ordered as the LEDs appear: left to right.

LED	Function
Microprocessor running (D4)	This LED flashes when the microprocessor is running. If this is not on, verify power to the board.
Actuator Increasing	This LED is on when the actuator is moving in the increasing direction.
Actuator Decreasing	This LED is on when the actuator is moving in the decreasing direction.
Fault	1 Flash - Indicates a loss of 4-20 mA signal (LOS).
	2 Flashes - Indicates a stall condition.
	3 Flashes - Indicates an electronic component failure.

Hazardous Locations

NOTE: This section covers actuator installation in Hazardous locations. All guidelines must be followed except when specifically noted.

WARNING - SHOCK HAZARD

- EXPLOSION PROOF and DUST-IGNITION PROOF ACTUATORS are not explosionproof or dust-ignitionproof until final installation is complete. Hazardous location enclosures must be installed in accordance with The National Electric Code requirements as well as state and local codes.
- Actuators must be installed in accordance with IEC/EN 60079-14, Electrical apparatus for explosive atmospheres, Part 14. Electrical installations in hazardous areas (other than mines).
- Do not open while energized.
- Do not open while in flammable gas or dust atmosphere.

ENVIRONMENT

Standard Voltages:

120/240 VAC 12-36 VDC, Power 36 VA

Temperature Limits:

-40 to 140 °F (-40 to 60 °C)

Vibration Limits:

4 - 15 Hz @ 0.5 ± 0.1 mm amplitude max.

Altitude:

Up to 3,280 ft. (1000 m) above mean sea level.

IDENTIFICATION LABEL



An identification label is attached to each actuator. When ordering parts, requesting information or service assistance, please provide all of the label information.

IECEx LABEL

Note: IECEx Applies to SM-1020 ONLY

Rotork Process Controls <small>5607 WEST DOUGLAS AVENUE MILWAUKEE, WISCONSIN 53218 (414) 461-9200 Fax: (414) 461-1024 E-Mail: rpdinfo@rotork.com</small>				WARNINGS: DO NOT OPEN WHILST ENERGIZED DO NOT OPEN WHILE A FLAMMABLE GAS OR DUST ATMOSPHERE IS PRESENT CABLE ENTRIES CAN REACH 105°C IN AN AMBIENT OF 60°C 
MODEL:		LAST TWO DIGITS OF SERIAL NUMBER DENOTE YEAR OF MANUFACTURE		
V:	Hz:	PH:	A:	
WIRING DIA:				
CUSTOMER P/N:				
CERTIFICATE No:		IECEx SIR 09.0074X		
RPC P/N:				
ALL CABLE ENTRIES TAPPED:				
Ex d IIB T4 Gb Ex t IIIC T105°C Db IP6X Tamb = -40°C to +60°C				
P/N 53B-046281-001				

ATEX LABEL

Rotork Process Controls <small>5607 WEST DOUGLAS AVENUE MILWAUKEE, WISCONSIN 53218 (414) 461-9200 Fax: (414) 461-1024 E-Mail: rpdinfo@rotork.com</small>				 1725	 II2Gdc
MODEL:		LAST TWO DIGITS OF SERIAL NUMBER DENOTE YEAR OF MANUFACTURE		WARNINGS: DO NOT OPEN WHILE A FLAMMABLE GAS AND/OR DUST ATMOSPHERE IS PRESENT CABLE ENTRIES CAN REACH 117°C IN AN AMBIENT OF 60°C CABLE ENTRY TYPE TAPPED 1/2" NPT 	
MV-1020 1020 / 5 / 10		1234E03			
V:	Hz:	PH:	A:		
WIRING DIA: 95C-036051-1					
CUSTOMER P/N:					
CERTIFICATE No:		SIRA02ATEX1188			
RPC P/N:					
Ex d IIB T4 Gb Ex t IIIC T135 °C Db IP6X Ta= -40 °C to +60 °C					
ENCLOSURE FASTENERS TO BE 304SS WITH MIN. YIELD STRENGTH OF 65,000psi OR MEDIUM CARBON STEEL QUENCHED AND TEMPERED MIN. YIELD STRENGTH OF 92,000psi (GRADE 5)					
P/N 53B-041591					

MODEL NUMBER: MV1020

Actuator Series

SERIAL NUMBER: 1234 E 03

Sequential Number Year Built
 Month Built

Hazardous Locations

HAZARDOUS RATINGS

ATEX II 2 GDc

Ex d IIB T4 Gb
 Ex t IIIc T135 °C Db IP6X
 Ta = -40 °C to +60 °C

IECEX- SM-1020 only

Ex d11b T4 Gb
 Ex t111C T 105 °C Db IP6x
 Tamb -40 to +60 °C

Actuator Characteristics relating to the hazardous environment:

- The actuator was designed in accordance to 94/9/EC
- The actuators are manufactured from aluminium alloy with stainless steel shafts and oilite bronze bushes and carbon steel fasteners.
- The lid securing fasteners must be steel quenched and tempered SAE Grade 5 or optional stainless steel. Grade A2-70 to EN ISO 3506 - 1:1997.
- All external seals are manufactured from Nitrile which is suitable for use in an ambient temperature range of -40 to +60 °C.
- The user must insure that the operating environment and any materials surrounding the actuator cannot lead to a reduction in the safe use of, or the protection afforded by, the actuator.
- Where appropriate, the user must ensure the actuator is suitably protected against its operating environment.
- The window had passed the Resistance to Impact test at a value related to the low risk of mechanical danger. This shall be taken into account by the user during installation and the equipment shall only be installed where there is a low risk of mechanical danger.

In accordance with Clause 5.1 of IEC EN60079-1, the critical dimensions of the flame paths are:

Flamepath	Maximum Gap (Inch)	Minimum L (Inch)
Enclosure Lid/Base	0.003	0.367 (I)/0.76 (L)
Output Shaft/ Output Shaft Bushing	0.007	0.625
Powered Hand Crank Shaft/ Hand Crank Shaft Bushing	0.007	0.495
Output Shaft Bushing/ Enclosure Base	-0.0005	0.620 MV 0.528 SM1010 0.617 SM1015 - 1020
Powered Hand Crank Bushing/Enclosure Lid	-0.0005	0.492
Non Powered Hand Crank/Enclosure Lid	0.003	0.820
Feedback Shaft to Bushing (MV only)	0.003	1.120
Feedback Shaft to Enclosure Base (MV only)	-0.0005	1.120

INSTALLATION

Installation should be carried out by a competent person in accordance with IEC/EN 60079-14, Electrical apparatus for explosive atmospheres, part 14 (electrical installations in hazardous areas other than mines).

- Where cables enter the unit, suitably certified and appropriate cable glands or conduit entries must be used.
- All unused cable entry points must be sealed with a suitable certified and appropriate blanking element.
- Must use certifiable cable or conduit entries. Also the blanking of unused cable entry points must be done with suitable certified blanking elements.
- Lid securing screws must be: Steel, quenched and tempered, SAE Grade 5 or optional stainless steel. Grade A2-70 to EN ISO 3506-1:1997.

MAINTENANCE

- Rotork Process Controls actuators are maintenance free. It is recommended that you remove the cover and visually inspect the actuator on an annual basis.
- Maintenance must be performed only by qualified personnel. Voltages hazardous to your health are applied to these actuators. De-energize all sources of power before removing actuator cover. Failure to follow these precautions may result in serious injury or death. ATEX approved actuators must be repaired and overhauled in accordance with IEC/EN 60079-19, Electrical apparatus for explosive atmospheres, Part 19. Repair and overhaul for apparatus used in explosive atmospheres (other than mines).
- Lubrication: The gearing is permanently lubricated. Re-lubrication is only required during repairs to the power gearing. The bronze bushings are lubricated with a few drops of SAE-10 or 20 NON-DETERGENT oil. Re-lubricate when repairs are made.
- **WARNING:** Static Hazard LA units must only be cleaned with a damp cloth.

Notes



rotork®

Redefining Flow Control



www.rotork.com

A full listing of our worldwide sales and service network is available on our website.

Rotork plc
Brassmill Lane, Bath, UK
tel +44 (0)1225 733200
fax +44 (0)1225 333467
email mail@rotork.com

USA
Rotork Process Controls
tel +1 (414) 461 9200
fax +1 (414) 461 1024
email rpcinfo@rotork.com

Scan with your smart phone
for more information on
this product range



PUB044-001-00
Issue 04/14

Formerly P371E. As part of a process of on-going product development, Rotork reserves the right to amend and change specifications without prior notice. Published data may be subject to change. For the very latest version release, visit our website at www.rotork.com
The name Rotork is a registered trademark. Rotork recognizes all registered trademarks.
Published and produced in the UK by Rotork Controls Limited. POWTG0414