

rotork®

Gears

**MANUAL
FOR
INSTALLATION
AND
OPERATING**

For gearbox model ILG/D

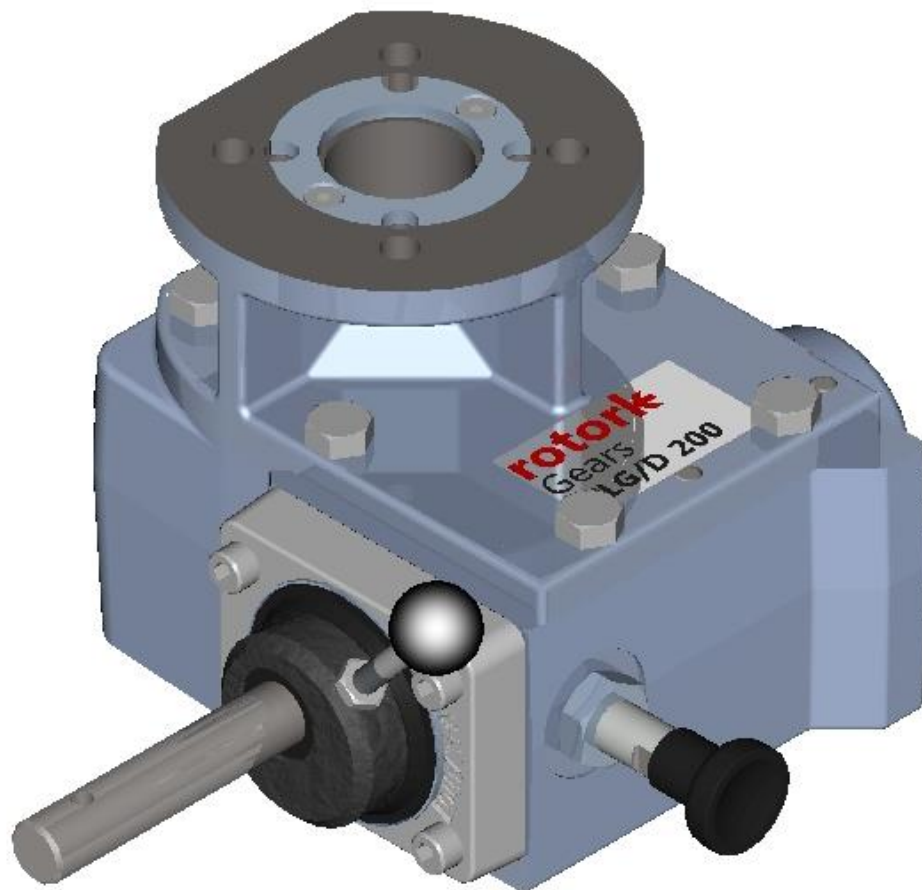

1. Preface	3
1.1 Introduction.....	3
2 Technical data Specifications.....	3
3. Handling and safety precautions	4
3.1 Qualification of staff	4
3.2 Commissioning	4
3.3 Operation.....	4
3.4 Protective measures.....	4
3.5 Maintenance	4
3.6 Storage	4
3.7 Long-term storage	4
3.8 Packing.....	5
3.9 Handling.....	5
3.10 IP rating and environmental conditions.....	5
3.11 Stem shaft water ingress.....	5
3.12 Paint	5
3.13 Primer.....	5
3.14 Seals	5
3.15 Grease	5
3.16 Correct use	6
3.17 Installation and operating	6
3.18 Disposal.....	6
3.19 Identification	6
3.20 Handweel type.....	6
3.21 Drive options and bottom side PCD options	7
4. Installation: mounting to the valve.	7
5. Adjustment of the stopscrews	9
6. Operating	12
7. Standard conditions.....	14
8. IP Rating	15
9. Certificates.....	16
10. Reach	17

1. Preface

1.1 Introduction

Rotork Gears BV produces gearboxes of different types and sizes. The model ILG/D is a declutchable override quarter turn gearbox for double acting pneumatic or electric actuators. The ILG/D is intended for manual operation of the valve, in case of failure of the automatic actuator system.

NB. This manual is valid only for the standard ILG/D gearboxes of Rotork Gears BV. For special versions, the specifications and model can differ. Rotork Gears BV is not responsible for any damage caused by incorrect use of the gearbox.

2 Technical data Specifications

2.1 maximum allowable input- and output torque.

Gearbox	Connection to actuator	connection to valve	Max. Torque [Nm]	
			Input	Output
Type	ISO 5211	ISO 5211/1		
ILG/D 100	F05-F07	F05-F07	13	150
ILG/D 200	F05-F07	F05-F07	26	250
ILG/D 600	F07-F10-F12	F07-F10-F14	60	750
ILG/D 900	F10-F12-F14	F10-F12-F14	125	1450
ILG/D 1500	F12-F14-F16	F10-F12-F14-F16	160	2485
ILG/D 2400	F14-F16	F12-F14-F16	188	3390
ILG/D 5000	F16-F25	F16-F25	298	7450
ILG/D 8000	F16-F25	F16-F25	120	8135
ILG/D 16000	F25-F30	F25-F30	140	17000
ILG/D 232-10	F07	F07-F10-F12	25	250

Table 1 : connection data of gearboxes

3. Handling and safety precautions

Be sure to read and understand this manual before installation and use of our gearboxes. All personnel working with this gearbox must be familiar with the instructions in this manual and observe the instructions given. Safety instructions must be observed to avoid personal injury or property damage.

3.1 Qualification of staff

Assembly, commissioning, operation, and maintenance must be carried out exclusively by suitably qualified personnel authorised by the end user or contractor. Prior to working on this product, the staff must have thoroughly read and understood these instructions and, furthermore, know and observe officially recognised rules regarding occupational health and safety. Work performed in explosive atmospheres is subject to special regulations which have to be observed. The end user or contractor is responsible for respecting and to be in control of these regulations, standards, and laws.

3.2 Commissioning

Prior to commissioning, it is important to check that all settings are in compliance with the requirements of the application. Incorrect settings might present a danger to the application, e.g. cause damage to the valve or the installation. The manufacturer will not be held liable for any consequential damage. Such risk lies entirely with the user.

3.3 Operation

Prerequisites for safe and smooth operation:

- Correct transport, proper storage, mounting and installation, as well as careful commissioning.
- Only operate the gearbox if it is in perfect condition while observing these instructions.
- Immediately notify Rotork Gears BV about any faults and damage and allow for corrective measures.
- Observe recognised rules for occupational health and safety. Observe the national regulations.

3.4 Protective measures

The end user or the contractor is responsible for implementing the required protective measures on site, such as enclosures, barriers or personal safety equipment for the staff.

3.5 Maintenance

To ensure reliable gearbox operation, the maintenance instructions included in this manual must be observed. Any gearbox modification requires the consent of the manufacturer. A Rotork Gears BV gearbox requires only little maintenance. To ensure that the gearbox is always ready to operate, we recommend for gearboxes the following measures. Three (3) months after commissioning and each year:

- Check the bolts on top of the gearbox;
- Check the bolts on the valve flange;
- Perform a test run every six months;
- Check the gearbox for leakage of grease;
- For gearboxes with permanent vibration and exposure above 60°C, checks should be performed at shorter intervals.

3.6 Storage

The gearboxes that are not yet installed need to be stored inside in a safe way to avoid accidents. Also avoid storage in areas subjected to high temperature extremes and /or areas subjected to large amounts of humidity and dust. Protect against floor dampness by storage on a shelf or on a wooden pallet. Apply suitable corrosion protection agent to bare surfaces.

3.7 Long-term storage

If the Gearbox must be stored for a long period (more than 6 months) the following points must be observed.

Prior to storage:

- Protect uncoated surfaces, in particular the output drive parts and mounting surface, with long-term corrosion protection agent.

At an interval of approximately 6 months:

- Check for corrosion. If first signs of corrosion show, apply new corrosion protection.

3.8 Packing

Our products are protected and packed by special packaging for the transport from the factory to the customer. The packaging is not suitable for storage outside. If long-term storage outside in the packaging from the factory is required, this should be mentioned during ordering and extra costs could be applicable. The packaging consists of environmentally friendly materials which can easily be separated and recycled. We use the following packaging material: wood, cardboard, paper, and PE foil. For the disposal of the packaging material, we recommend recycling and collection centres.

3.9 Handling

Never drop the gearbox or otherwise subject it to strong impact. Lift the gearbox horizontal on the valve. The input shaft or hand wheel cannot be used for lifting the gearbox. Do not lift the gearbox when it is assembled to the valve.

3.10 IP rating and environmental conditions

The enclosure protection IP65 (on request IP67 - IP68) only refers to the interior of the gearboxes and not to the stem shaft coupling compartment. (*See table. 6 - IP rating*) The Rotork Gears ILG/D gearboxes can be used at ambient temperatures from -20 to + 120°C. Other temperature ranges are available on request. Suitability for any specific application is not claimed. IP rating is done in accordance to a standard test protocol. It is recommended that users carry out tailor made tests to prove the product is fit for purpose for the specific environmental conditions. For example marine environment, tropical conditions, cold or very hot conditions, chemical sites with acids or salty conditions requires the end user to assess the fit for purpose. When the product is used in areas with high temperature fluctuations it is recommended to use pressure compensators to prevent pressure differences between the outside environment and the interior of the gearbox.

3.11 Stem shaft water ingress

Water can enter into the coupling compartment along the valve shaft, this would lead to corrosion. Therefore a suitable anticorrosive (or sticky grease) must be applied on the inside top bore hole of the gearbox and coupling before mounting. When the manual override is operated in a humid or corrosive environment it is required to apply liquid seal on the bottom flange between the valve and the ILGD and between the top flange of the ILGD and the actuator on top. This will prevent corrosion of the coupling.

3.12 Paint

We deliver our gearboxes in different RAL colours, our standard average paint thickness is 60 microns, suitable for installation in a clean and dry industrial indoor environment. Our process consists of a phosphating pre-treatment followed by our standard DTM (direct to metal) paint system (Polyaspartic) or primer paint. Other paint systems are on request. For exposure to corrosive outside environment and other non-standard environments, paint system are to be advised by the customer including IP rating. On request we can deliver other paint systems and thicknesses (*see table 5 standard conditions and options*)

3.13 Primer

On request we deliver gearboxes in primer. Standard primer is a 1K industry primer which has a maximal lifetime of 1, 5 month and must be stored only in indoor, clean and dry conditions. On request zinc primer can be supplied which has a maximal lifetime of 3 months when free from zinc salts and free from contamination and stored in a clean exterior. In industrial or marine conditions this should be reduced to the practical minimum.

3.14 Seals

Rotork Gears BV is using a silicone low volatile liquid seal between cover lid and body. Loosening the top bolts of the cover plate from the gearbox can break the seal resulting to leakage. Rotork Gears BV will not be held liable when the top bolts are opened without notification. Once opened a new liquid sealing must be applied. Liquid seals kits may be obtained from Rotork Gears BV. During the order process it should be mentioned when gearboxes are exposed to high- or low temperatures. Seals made of elastomeric materials are subject to ageing. All NBR seals subject to rotating parts are lubricated with MI-setral 9-M. Gearboxes for low temperatures up to minus 60 degrees Celsius are built with special EPDM O-rings.

3.15 Grease

Rotork Gears BV is applying grease that is non-self-igniting and do not present an explosion hazard. Dependent on the environmental conditions different greases can be used such as high temperature grease, silicone free grease, foodgrade grease or oxygen free grease. Gearboxes for minus 60 degrees Celsius are built with 75%

filling level of grease. Gearboxes are filled for life but on customer request grease nipples are an option to be mentioned during order process.

3.16 Correct use

Prior to installation, be sure the gearbox will **NOT** be overloaded during normal use. For this, verify that valve size and required opening torque do not exceed the values given for the gearbox. For the maximum allowable torque on the gearbox, (see table 1). ILGD gearboxes can only be used for manual operation.

3.17 Installation and operating

Not observing the rules as stated in this manual, can lead to damage and/or personal injuries. Qualified personnel must be fully aware of the instructions as described in this manual. Only when the instructions are observed, correct operation of the gearboxes can be guaranteed.

3.18 Disposal

Never dispose a gearbox at a general disposal site/depot. The gearbox has to be offered to a disposal depot for recycling. The iron parts can be used for recycling. The seals are of nitrile and can be used for plastic recycling. The grease may not be discharged to sewer- or surface water. It has to be disposed according to local regulations.

3.19 Identification

Each gearbox has a nameplate. On this nameplate you find the following standard information:

- Model type - Rotork Gears BV order.nr with line.nr - Production date and other customer information, when required.

N.B. Information on the name plate is important and is required in case of non-conformities or requests. In case of non-conformity, please send a description of the complaint, details from the nameplate with clear photograph(s) to sales.gearsbv@rotork.com.

3.20 Handwheel type

Size in mm	Handwheel Type - weight Kgs (lbs)				
	CD (casted)	PS (pressed steel)	SG (Steel welded)	S (Stainless steel)	F (Steel welded)
50	0.11 (0.24)	-	-	-	-
75	0.21 (0.46)	-	-	-	-
100	0.32 (0.71)	0.15 (0.33)	-	-	-
125	0.54 (1.19)	0.2 (0.44)	-	-	-
150	-	-	1 (2.20)	0.4 (0.88)	-
160	-	0.35 (0.77)	-	-	-
200	1 (2.20)	0.75 (1.65)	1.35 (2.98)	1 (2.20)	1 (2.20)
250	-	1.5 (3.31)	1.4 (3.09)	-	-
300	-	-	1.8 (3.97)	-	1.5 (3.31)
315	-	2 (4.41)	-	-	-
350	-	-	2.3 (5.07)	1.5 (3.31)	-
400	-	3.5 (7.72)	2.8 (6.17)	-	2.2 (4.85)
450	-	-	3 (6.61)	-	-
500	-	-	3.5 (7.72)	-	3 (6.61)
600	-	-	4.5 (9.92)	-	3.2 (7.05)
700	-	-	5 (11.02)	-	5.5 (12.13)
800	-	-	5.5 (12.13)	-	6.6 (14.55)
900	-	-	6 (13.23)	-	7.2 (15.87)

Table 2. Handwheel type – weight Kgs (lbs)

3.21 Drive options and bottom side PCD options

Figure 1 shows the different drive options. Special drive requirements on request. We deliver ILG/D standard off-center. On request we can deliver on center with reduced tapping depths and dowel pin hole depths (See figure 2)

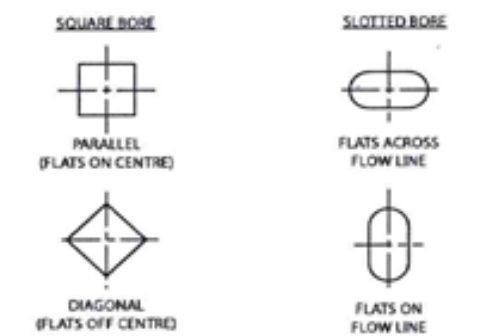

Figure 1. Drive options

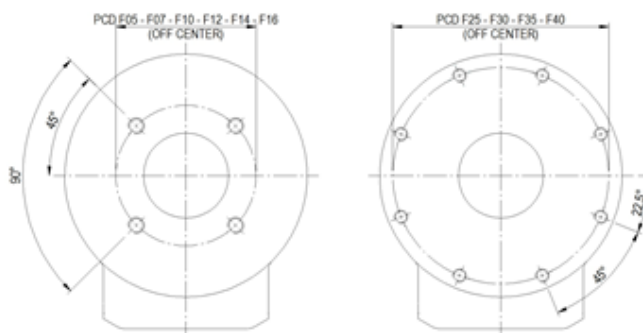

Figure 2: Bottom PCD options

4. Installation: mounting to the valve.

The ILG/D is a manual declutchable override quarter turn gearbox for double acting actuators.

For connection data, maximum allowable input- and output torque refer to table 1. This manual describes the installation of the gearbox and its parts. The intention of the ILG/D gearbox is to operate the valve in case of a failing actuator system or emergency situation. Standard we deliver our ILG/D gearboxes in right handed position, the gearbox is observed from above (top view) with set screws pointing downwards. The shaft is than at the top pointing to the right (right handed gearbox).

The gearbox is designed to be mounted on top of the valve as in picture 4. The Gearbox is not constructed for heavy side loads. Apart from side loads in case of horizontal or mounting under an angle, also the selector for manual or auto is not designed for use under an angle in a humid or corrosive environment as under an angle water will deposit on the selector and potentially give corrosion when not operated frequently. This can cause malfunction.

1. The gearbox is standard delivered in the closed position. If the ILGD needs to be delivered in open position, this needs to be mentioned during in the order.
2. It is recommended to mount a handwheel on the inputshaft, before assembling the gearbox to the valve.

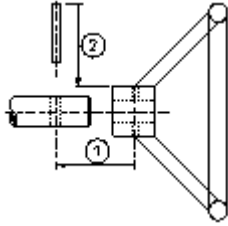

Figure 3: mounting handwheel

3. Check if the bolt circle of the flanges (of gearbox and valve) coincide. Also check if the valve stem and the bore at the bottom of the gearbox match.
4. Make sure the valve is in the closed position. If not, close the valve before continuing.
5. Check if the gearbox is in fully closed position by turning the handwheel clockwise.
6. In case of use of studbolts for fixing the gearbox to the valve, it is recommended to screw them into the bottom flange of the gearbox before mounting the gearbox to the valve.
7. The use of a gasket or liquid seal between the flange of the valve and gearbox is recommended especially in humid or corrosive environment as previously described.
8. The gearbox is mounted perpendicular to the valve (see figure 4).

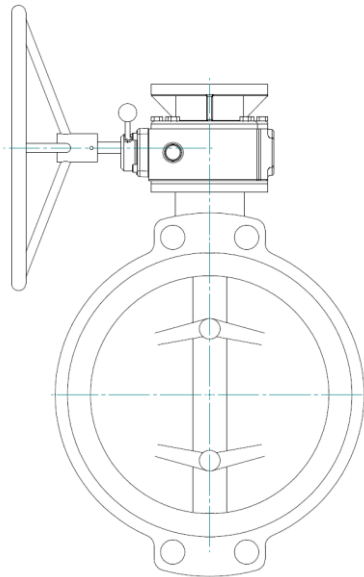

Figure 4: Gearbox perpendicular and on top of the valve

9. Fasten the gearbox to the valve with nut and ring. In case of use of bolts, for the maximum tapping depth, see table 3. For tightening, refer to standard VDI 2230.

PCD	F05	F07	F10	F12	F14	F16	F25	F30	F35	F40
max. screw depth	8	11	13	16	18	18	18	18	30	36

Table 3: maximum tapping depth per pitch center diameter

10. The 3/2-valve is optional and meant for gearbox mode detection. The 3/2 vent valve is open (and vents to atmosphere) with the gearbox in manual mode.

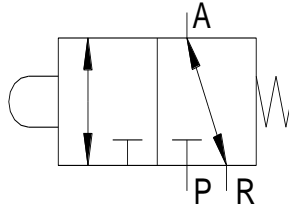

Figure 5: port designation

11. The assembly is now ready for adjustment. (See chapter 5).

5. Adjustment of the stopscrews

The gearbox is mounted on top of the valve (see chapter 4).

1. In case of a pneumatic actuator, be sure the actuator depressurised.
2. Put the gearbox in the manual-mode by turning the handle 90 degrees counter clockwise (see 'operating' and/or figure 6: 1 (pull the nob) → 2 turn the selector → 3 loose the nob and make sure it is released in.
3. Turn the valve into fully closed position by turning the handwheel clockwise. When the fully closed position can not be achieved, loosen the stopscrew-close (see figure 6) Continue turning the handwheel until the valve is fully closed.
4. Turn the stop screw back into the gearbox until blocked (handtight). Secure the stopscrew–close with the counternut.

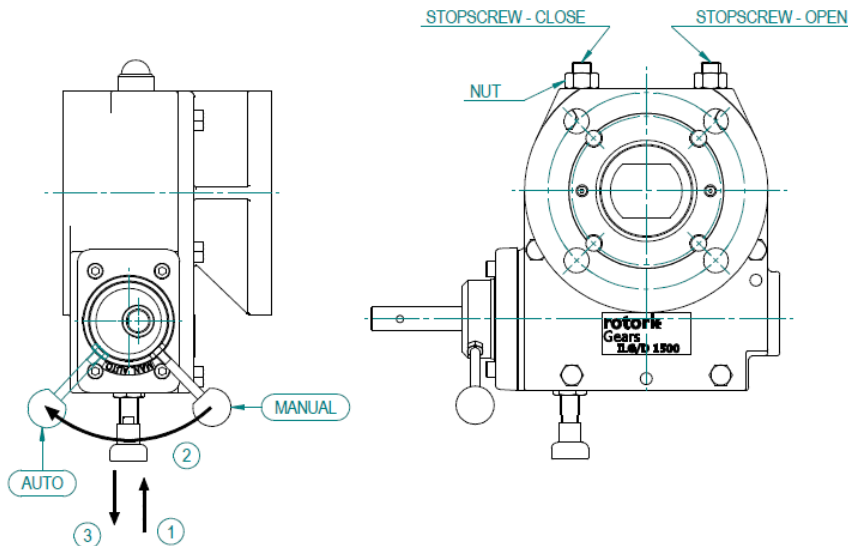

Figure 6: ILG/D gearbox stopscrew adjustment

5. Open the valve by turning the handwheel counter-clockwise. When the fully open position can not be achieved, loosen the stopscrew-open (see figure 6). Continue turning the handwheel until the valve is fully open.
6. Turn the stop-screw back into the gearbox until blocked (handtight). Secure the stopscrew–open with the counternut.
7. Close the valve completely with the handwheel.
8. Pull the knob outwards (3) and turn the handle (clockwise) until knob falls back into its locked-position (2).
9. Adjustment completed. The gearbox is now ready for manual or automatic operation.
10. Prior to mounting an actuator,
 - a. Adjust the stopscrews.
 - b. Position the driveshaft (see figure 7) in top of the gearbox.
 - c. Make sure the actuator is in closed position.

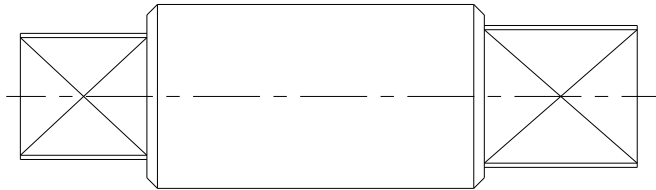

Figure 7: Driveshaft example from an ILG/D gearbox

For the ILGD gearboxes, the set screws contain bonded seals. This is to prevent oil leakage from inside the gearbox when the gearboxes are mounted on the valve. When adjusting the set screws more than once it may result in a loss of the bonded seal and it is advised to apply Loctite Threadlock 242. It is also important to lock the screws properly with a torque according to the table below.

TYPE	SCREW SIZE	TORQUE TIGHTNESS lbs ft	TORQUE TIGHTNESS Nm
SOCKET HEAD	M4	2 - 3	3 - 4
	M5	4 - 6	5 - 8
	M6	7 - 10	9 - 13
	M8	16 - 24	21 - 32
	M10	32 - 47	42 - 63
	M12	55 - 82	74 - 110
	M16	136 - 204	182 - 247
	M20	266 - 400	357 - 535
HEXAGON HEAD	M6	4 - 6	5 - 8
	M8	10 - 15	13 - 20
	M10	19 - 29	26 - 39
	M12	34 - 51	46 - 68
	M16	84 - 126	113 - 169
	M20	170 - 255	231 - 364
	M24	294 - 441	399 - 598
DURLOK	M8	30 - 45	40 - 60
	M10	57 - 86	77 - 115
	M12	101 - 151	135 - 203
	M16	246 - 370	330 - 496
	M20	476 - 713	638 - 956
SOCKET CAP w / NORDLOCK WASHER	M8	18 - 27	24 - 36
	M10	35 - 52	47 - 71
	M12	60 - 91	82 - 124
	M16	148 - 221	200 - 300
	M20	289 - 434	392 - 588
	M24	502 - 752	680 - 1020

Table 4: Tighten force in Nm

6. Operating

The ILG/D is a declutchable manual override quarter turn gearbox for double acting pneumatic or electric actuators. For maximum allowable input- and output torque, refer to table 1.

When switching from auto to manual or during operating the manual gearbox in manual mode, it must be made sure the actuator is not operating or able to operate the gearbox as this may lead to damage.

The gearbox is delivered in automatic mode: valve-operating by actuator.

1. The gearbox is manually operated by handwheel.
2. Prior to manual operation, the gearbox has to be put into manual mode. To achieve this, refer to figure 8 and follow the next points :
 - i. Pull the knob outwards (3). Secure the knob in this position.
 - ii. Turn the handle counter clockwise (2) and release the knob. Continue turning the handle until the knob falls back into locking position (1).
- NB When the handle can not be fully turned over $\pm 90^\circ$, turn the handwheel slightly. Continue turning the handle until full engagement is achieved (knob returns to start position).
- iii. The gearbox is ready for manual operation.

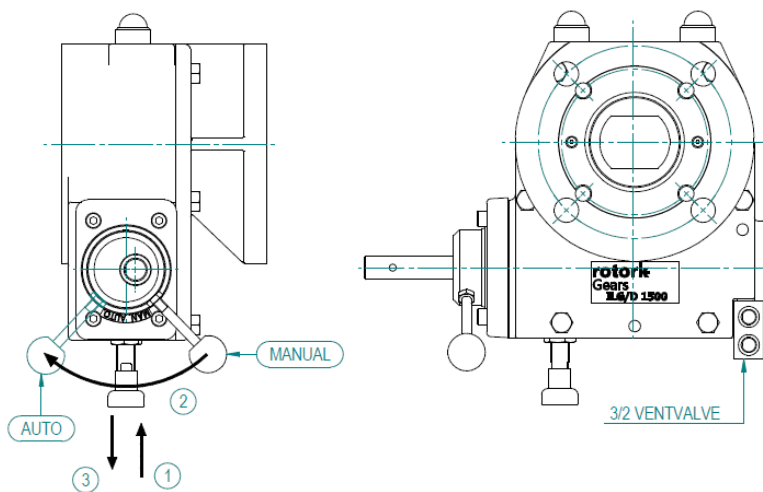

Figure 8: ILG/D gearbox

3. To close the valve, turn the handwheel clockwise.
4. Stop turning until the required valve position is achieved. The number of turns needed from totally open to totally close the valve is in table 4.
5. When the valve can not be totally opened (or closed), analyse the cause first to and solve it.
6. In case of malfunction of the gearbox Rotork Gears can be contacted for help. It is important to explain the malfunction, include all details of the nameplate together clear photographs. The report and the pictures can be send to sales.gearsbv@rotork.com.
7. Turn the hand wheel the end stops are reached until blocked.
8. Declutch the gearbox:
 - i. Pull de knob outwards (3).
 - ii. Turn the handle clockwise (2) and release the knob. Continue turning the handle until the knob falls into its locking position (1).
9. In case of opening the valve, follow procedure described in the previous points, except point 3: to open the valve, turn the handwheel counter-clockwise.

type gearbox	Number of turns
ILG/D 100	10
ILG/D 200	8.75
ILG/D 600	11.5
ILG/D 900	10.75
ILG/D 1500	14.25
ILG/D 2400	17
ILG/D 5000	26
ILG/D 8000PR3	78
ILG/D 16000PR6	117
ILG/D 232-10	9.25

Table 5: number of turns to open / close.

7. Standard conditions

Conditions	
Enclosure protection (See table 4: IP rating)	Standard: IP65 Option: IP67 Option: IP68
Paint protection Options:	Standard: <ul style="list-style-type: none"> ILG/D range 60 microns. Suitable for installation in clean and dry industrial indoor units. 120 microns. Suitable for installation in industrial outdoor units water, gas or power plants with a low pollutant concentration Higher thickness on request. Suitable for installation in occasionally or permanently outdoor atmosphere with a moderate pollutant concentration (e.g. in waste water treatment plants, chemical/oil/gas industry) Other paint systems on request
Pre treatment	Standard: Chemical treatment (phosphating) Option: Sandblasting SA 2.5 Option: Other pre-treatments on request
Paint Paint Primer Zinc primer	Standard: QD polyaspartic direct to metal paint Options: Epoxy coat, other paint systems on request Standard: 1K industry primer (maximum lifetime 1,5 month stored only in indoor, clean and dry conditions) Options: Zinc primer (maximum lifetime 3 months when free from zinc salts and free from contamination and stored in clean exterior conditions. In industrial or marine conditions this interval should be reduced to the practical minimum.
Colour Paint thickness Paint thickness Paint thickness Paint thickness	Standard: different RAL colours on request Standard: 60 microns (QD polyaspartic) Options: 120 microns higher thickness on request (Epoxy coat or QD polyaspartic) Standard: 40 microns (1K industry primer) Options: 40 – 60 microns (zinc primer)
Grease Ambient temperature	Standard: Renolit CLX 2 grease Standard: – 20°C to + 120°C Options: – 40°C to + 120°C Options: – 60°C to + 120°C Options: Other types of grease (low temperature, food, silicone free or high temperature) on request
Set screws cover Shafts Handwheels Padlockable plunger system	Standard: Plastic nutcaps with dubo ring Option: W-nuts with dubo ring Option: W-nuts with washer for – 60°C specification Option: W-nuts with copper ring Standard: Standard protected shafts Option: Stainless steel shaft different classifications Option: extended shaft Standard: Pressed steel RAL9005 Standard: Steel welded RAL9005 Option: Stainless steel handwheels Option: To prevent unauthorized people to operate the gearbox

Table 6: Standard conditions and options

8. IP Rating

Solid Particle protection

The first digit indicates the level of protection that the enclosure provides against access to hazardous parts (e.g., electrical conductors, moving parts) and the ingress of solid foreign objects.

Level	Object size protected against	Effective against
6	Dust tight	No ingress of dust; complete protection against contact

Liquid ingress protection

The second digit indicates the level of protection that the enclosure provides against harmful ingress of water.

Level	Protected against	Testing for	Details
5	Water jets	Water projected by a nozzle (6.3 mm) against enclosure from any direction shall have no harmful effects.	Test duration: at least 3 minutes Water volume: 12.5 litres per minute Pressure: 30 kPa at distance of 3 m
6	Powerful water jets	Water projected in powerful jets (12.5 mm nozzle) against the enclosure from any direction shall have no harmful effects.	Test duration: at least 3 minutes. Water volume: 100 litres per minute. Pressure: 100 kPa at distance of 3m.
7	Immersion up to 1 m	Ingress of water in harmful quantity shall not be possible when the enclosure is immersed in water under defined conditions of pressure and time (up to 1 m of submersion).	Test duration: 30 minutes Immersion at depth of at least 1 m measured at bottom of device, and at least 15 cm measured at top of device
8	Immersion beyond 1 m	The equipment is suitable for continuous immersion in water under conditions which shall be specified by the manufacturer. Normally, this will mean that the equipment is hermetically sealed. However, with certain types of equipment, it can mean that water can enter but only in such a manner that it produces no harmful effects.	Test duration: continuous immersion in water Depth specified

Table 7. IP rating

9. Certificates

Atex

Directive EC 94/9/EG states the directive only applies to equipment which is capable of causing an explosion through its own potential sources of ignition. The gearboxes from type AB, 242, 232, 300, ILG/S and ILG/D don't have their own potential source of ignition, so directive EC 94/9/EG doesn't apply. Therefore we state that:

Operation of gearboxes type series AB, 232 and 300 with the marking:



II 2 G D c 120 C

In areas with explosive gas atmospheres Zone I and II Category 2 (and 3)
and explosive dust atmospheres Zone 21 and 22 Categories 2 (and 3)



- II** : This product meets the requirements for explosion prevention
- 2** : in a potential explosive surrounding, other than in mines,
- G D** : with a high level of safety, based on normal operation and anticipated risks
- c** : suitable for a possible explosive atmosphere caused by gases, vapours, mists of air/dust mixtures
- 120C** : safety obtained by constructive solutions.
- 120C** : indicating the maximum surface temperature in °C

Certificates of conformity

Rotork Gears BV certify that the Gearbox models AB, 242, 232 and 300 supplied conforms in all respects to our specifications and have been subject to our Quality System conforming to BS EN ISO9001:2008

Other certificates

For other certificates please contact our sales department, these are on request an need to be ordered in the preliminary stages. The following certificates we can provide:

- EUR 1 certificate
- Certificate of origin
- GOST certificate
- Certificate of Conformity
- 2.2 certificate
- Long term supplier declaration

10. Reach

Dear Customer,

REACH REGULATIONS: ROTORK'S POSITION

Rotork's responsibilities with regard to the REACH regulations are under the user section of the regulations; Rotork are not manufacturers or importers of chemicals or substances however we Use substances that will contain chemicals.

Statement:

Rotork use only main stream materials such as aluminium, copper and iron and substances such as oil, grease and brand named products, which are highly likely to be registered under REACH. Our products, including finish coatings, contain no Substances listed below.

Substance Name	CAS Number
Anthracene	120-12-7
4,4'- Diaminodiphenylmethane	101-77-9
Dibutyl phthalate	84-74-2
Cyclododecane	294-62-2
Cobalt dichloride	7646-79-9
Diarsenic pentaoxide	1303-28-2
Diarsenic trioxide	1327-53-3
Sodium dichromate, dihydrate	7789-12-0
5-tert-butyl-2, 4, 6-trinitro-mxylene (musk xylene)	81-15-2
Bis (2-ethyl(hexyl)phthalate) (DEHP)	117-81-7
Hexabromocyclododecane (HBCDD)	25637-99-4
Alkanes, C10-13, chloro (Short Chain Chlorinated Paraffins)	85535-84-8
Bis(tributyltin)oxide	56-35-9
Lead hydrogen arsenate	7784-40-9
Triethyl arsenate	15606-95-8
Benzyl butyl phthalate	85-68-7

Rotork do not foresee any loss of supply in any of the materials and substances that we current use in our products.