



Keeping the World Flowing
for Future Generations



HOB/MPR Series

Hand Operated Bevel Gearbox

Rotork HOB/MPR gear operators are manufactured from high quality materials and life tested ensuring that maximum performance, quality and reliability are consistently maintained.

Operating temperature normally ranges from -40 to +120 °C (-40 to +250 °F), although other temperature ranges are available on request.

Application

Designed for manual applications, the HOB/MPR bevel gear operators are for use on gate valves, globe valves and penstocks.

Environmental Specification

- Sealed to IP67 for standard environment
- Optional IP68

Features

- Carefully chosen ratios to meet manual rim effort requirements
- Protected steel input shaft
- Totally enclosed gearing
- Cast iron gearcase
- Ductile iron baseplate
- Grease filled for life
- Maintenance free
- Protected fasteners
- Primed finish

Options

- High temperature to +150 °C (+302 °F) or +200 °C (+392 °F)
- Low temperature to -60 °C (-76 °F)
- Stainless steel input shaft
- Coating for aggressive environments
- Mechanical and electrical position indicators
- Fixed and flexible extensions
- Interlock safety system
- Padlockable handwheels
- Two speed input reducers
- 2 or 3 input shafts available at 90° and 180° to each other
- Form A, B & C available
- Gloss paint finish

HOB/MPR Series

Gearbox Selection Chart

Gearbox	Output Torque (Nm)	Max Thrust (kN)	Ratio*		Mechanical Advantage**	
HOB3	315	75	3:1		2.6	
HOB4	380	54	2:1		1.7	
HOB4	680	54	6:1		5.1	
HOB4	850	54	4:1	16.7:1	3.4	12.1
HOB5	680	178	6:1		5.1	
HOB5	850	178	4:1	16.7:1	3.4	12.1
HOB6	1355	178	6:1		5.1	
HOB6	1700	178	16.7:1		12.1	
HOB7	1355	356	6:1		5.1	
HOB7	1700	356	16.7:1		12.1	
HOB8	2033	356	25.1:1		18.1	
HOB8	2376	356	24:1		17.3	
HOB8	2550	356	40.5:1		29.3	
HOB9	2033	445	25.1:1		18.1	
HOB9	2376	445	24:1		17.3	
HOB9	2550	445	40.5:1		29.3	
HOB10	3563	445	36:1		26	
HOB10	5423	445	60.8:1		43.9	
HOB11	3563	670	36:1		26	
HOB11	5423	670	60.8:1		43.9	
HOB12	8018	670	81:1		58.5	
HOB12	10846	670	153.6:1		104.7	
HOB13	8018	1000	81:1		58.5	
HOB13	10846	1000	153.6:1		104.7	
HOB14	8018	1557	81:1		58.5	
HOB14	10846	1557	153.6:1		104.7	

*Other ratios are possible. **The published M.A. is achieved after a few cycles.

DSB - Dual Shaft Bevel



180° version



90° version

90° & 180° DSB available for HOB4 to HOB11.

180° DSB available for HOB12 to HOB14.

Material Specification

Description	Material	UK Standard	USA Standard	DIN Standard	ISO Standard
Gearcase & End Cap	Cast Iron or SG Iron	BS EN 1561 EN-GJL-250 or BS EN 1563 EN-GJS-450-10	ASTM A48 35B/40B or ASTM A536 65-45-12	GG-25 or GGG-40	ISO 185 JL/250 or ISO 1083 JS 450-10
Baseplate	Ductile Iron	BS EN 1563, EN-GJS-450-10	ASTM A536 65-45-12	GGG-40	ISO 1083 JS 450-10
Output Gear	Ductile Iron or Steel	BS EN 1563 EN-GJS-700-2 or GB 3077-88 40Cr	ASTM A536 100-70-03 or ASTM A29 5140	GGG-70 or 41Cr4	ISO 1083 JS 700-2 or ISO 683 41Cr4
Input Gear	Steel	BS 970 605M36T	AISI/SAE 4340	42MnMo7	ISO 683 42 MnMo 7
Input Shaft	Protected Steel	STEEL BS970 605M36T WITH ELECTROPHORESIS TREATMENT	AISI/SAE 4340	42MnMo7	ISO 683 42 MnMo 7
Drive Sleeve Form B	Steel	BS 970 070M20	AISI/SAE 1023	C22	ISO 683 C20
Drive Sleeve Form A	Aluminium Bronze	BS 1400 AB2	ASTM B505 C95800	G-CuAl10Ni	ISO 4382 CuAl10Fe5Ni5
Fixing Screws	HT Steel Metric	BS 3692			
O-Ring Seals	Nitrile				
Thrust Bearings	Needle Roller Bearings (HOB14: Cylindrical roller bearings)				
Grease	Renolit CL-X2				
Planet Gear	Carbon Steel	EN 10083 C45	ASTM A29 1045	C45	ISO 683 C45E4
Planet Carrier	Ductile Iron	BS EN 1563, EN-GJS-400-15	ASTM A536 60-40-18	GGG-40	ISO 1083 JS 450-10
Planetary Gearcase	Ductile Iron	BS EN 1563, EN-GJS-400-15	ASTM A536 60-40-18	GGG-40	ISO 1083 JS 450-10

Note: Because of the company's policy of continuous improvement, Rotork reserves the right to change specification details without prior notice.

HOB/MPR Series

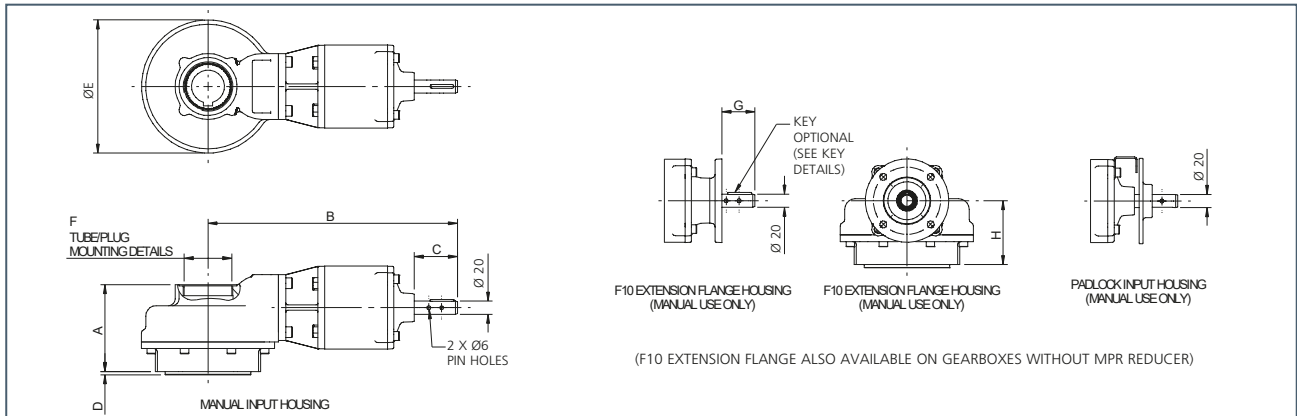

Gearbox	Ratio	Output	A	B	C	D	ØE	Key Details	F	G	H	Max Bore Rect. Key (mm)	Max Thread (inch)	Max Thread (mm)	Weight (kg)
HOB3	3:1	F10 & F12	77	178	81	3	190	6 x 6 x 36	M52x2	50	71	40	1.57	40	7
HOB3	3:1	F14	77	178	81	4	190	6 x 6 x 36	M52x2	50	71	40	1.57	40	7
HOB3	3:1	F16*	87	178	81	5	200	6 x 6 x 36	M52x2	50	81	40	1.57	40	8
HOB4	2.1, 4.1 & 6:1	F10	109	228	106	3	202	6 x 6 x 40	2.5" BSP	51	74	40	1.75	45	13
HOB4	16.7:1	F10	109	379	66	3	202	6 x 6 x 36	2.5" BSP	50	74	40	1.75	45	16
HOB5	4 & 6:1	F14	132	228	106	4	202	6 x 6 x 40	2.5" BSP	51	97	52	2.125	55	17
HOB5	4 & 6:1	F16	132	228	106	5	202	6 x 6 x 40	2.5" BSP	51	97	52	2.125	55	24
HOB5	16.7:1	F14	132	379	66	4	202	6 x 6 x 36	2.5" BSP	50	97	52	2.125	55	27
HOB5	16.7:1	F16	132	379	66	5	202	6 x 6 x 36	2.5" BSP	50	97	52	2.125	55	29
HOB6	6:1	F14	141	251	66	4	260	6 x 6 x 40	3.5" BSP	51	102	52	2.125	55	28
HOB6	6:1	F16	141	251	66	5	260	6 x 6 x 40	3.5" BSP	51	102	52	2.125	55	28
HOB6	16.7:1	F14	141	402	66	4	260	6 x 6 x 36	3.5" BSP	50	102	52	2.125	55	35
HOB6	16.7:1	F16	141	402	66	5	260	6 x 6 x 36	3.5" BSP	50	102	52	2.125	55	39
HOB7	6:1	F16	159	251	66	5	260	6 x 6 x 40	3.5" BSP	51	120	68	2.875	73	35
HOB7	6:1	F25	159	251	66	5	267	6 x 6 x 40	3.5" BSP	51	120	68	2.875	73	45
HOB7	16.7:1	F16	159	402	66	5	260	6 x 6 x 36	3.5" BSP	50	120	68	2.875	73	42
HOB7	16.7:1	F25	159	402	66	5	267	6 x 6 x 36	3.5" BSP	50	120	68	2.875	73	52
HOB8	25.1:1 & 24:1	F16	191	474	66	5	320	6 x 6 x 36	4" BSP	50	130	68	2.875	73	62
HOB8	40.5:1	F16	191	408	66	5	320	6 x 6 x 36	4" BSP	50	130	68	2.875	73	66
HOB8	25.1:1 & 24:1	F25	191	474	66	5	320	6 x 6 x 36	4" BSP	50	130	68	2.875	73	68
HOB8	40.5:1	F25	191	408	66	5	320	6 x 6 x 36	4" BSP	50	130	68	2.875	73	72
HOB9	25.1:1 & 24:1	F25	197	474	66	5	320	6 x 6 x 36	4" BSP	50	136	76	3.375	86	77
HOB9	40.5:1	F25	197	408	66	5	320	6 x 6 x 36	4" BSP	50	136	76	3.375	86	81
HOB9	25.1:1 & 24:1	F30	197	474	66	5	355	6 x 6 x 36	4" BSP	50	136	76	3.375	86	83
HOB9	40.5:1	F30	197	408	66	5	355	6 x 6 x 36	4" BSP	50	136	76	3.375	86	87
HOB10	36:1	F25	216	519	66	5	412	6 x 6 x 36	5" BSP	50	155	76	3.375	86	112
HOB10	60.8:1	F25	216	519	66	5	412	6 x 6 x 36	5" BSP	50	155	76	3.375	86	116
HOB10	36:1	F30	216	519	66	5	412	6 x 6 x 36	5" BSP	50	155	76	3.375	86	116
HOB10	60.8:1	F30	216	519	66	5	412	6 x 6 x 36	5" BSP	50	155	76	3.375	86	120
HOB11	36:1	F30	237	519	66	5	412	6 x 6 x 36	5" BSP	50	176	96	3.875	100	132
HOB11	60.8:1	F30	237	519	66	5	412	6 x 6 x 36	5" BSP	50	176	96	3.875	100	136
HOB11	36:1	F35	237	519	66	5	412	6 x 6 x 36	5" BSP	50	176	96	3.875	100	142
HOB11	60.8:1	F35	237	519	66	5	412	6 x 6 x 36	5" BSP	50	176	96	3.875	100	146
HOB12	81:1	F30	238	574	66	5	520	6 x 6 x 36	Ø195 Bore (4 x M10 on 220 PCD)	50	176	96	3.875	100	183
HOB12	81:1	F35	238	574	66	5	520	6 x 6 x 36	Ø195 Bore (4 x M10 on 220 PCD)	50	176	96	3.875	100	191
HOB12	153.6:1	F30	238	614	66	5	520	6 x 6 x 36	Ø195 Bore (4 x M10 on 220 PCD)	50	176	96	3.875	100	177
HOB12	153.6:1	F35	238	614	66	5	520	6 x 6 x 36	Ø195 Bore (4 x M10 on 220 PCD)	50	176	96	3.875	100	183
HOB13	81:1	F35	254	574	66	5	520	6 x 6 x 36	Ø195 Bore (4 x M10 on 220 PCD)	50	192	121	5	127	211
HOB13	81:1	F40	254	574	66	5	520	6 x 6 x 36	Ø195 Bore (4 x M10 on 220 PCD)	50	192	121	5	127	226
HOB13	153.6:1	F35	254	614	66	5	520	6 x 6 x 36	Ø195 Bore (4 x M10 on 220 PCD)	50	192	121	5	127	199
HOB13	153.6:1	F40	254	614	66	5	520	6 x 6 x 36	Ø195 Bore (4 x M10 on 220 PCD)	50	192	121	5	127	221
HOB14	81:1	F40	366	574	66	8	520	6 x 6 x 36	Ø195 Bore (4 x M10 on 220 PCD)	50	304	130	5.875	150	354
HOB14	153.6:1	F40	366	614	66	8	520	6 x 6 x 36	Ø195 Bore (4 x M10 on 220 PCD)	50	304	130	5.875	150	311

All dimensions in mm. * F16 does not meet ISO 5210 minimum thread engagement of 30mm; HOB3 has 20mm engagement.

Handwheel Selection Chart

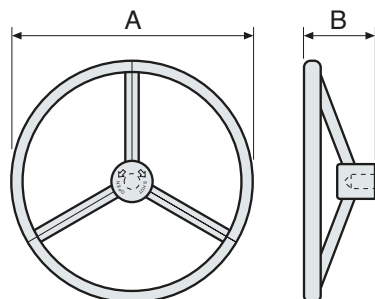

SG series handwheel

Handwheel Dimensions

Type	A	B
SG200	Ø200 (8")	80 (3,15")
SG250	Ø250 (10")	110 (4,33")
SG300	Ø300 (12")	115 (4,53")
SG350	Ø350 (14")	120 (4,72")
SG400	Ø400 (16")	130 (5,12")
SG450	Ø450 (18")	150 (5,91")
SG500	Ø500 (20")	150 (5,91")
SG600	Ø600 (24")	150 (5,91")
SG700	Ø700 (28")	150 (5,91")
SG800	Ø800 (32")	150 (5,91")
SG900	Ø900 (36")	160 (6,30")
SG1000	Ø1000 (40")	160 (6,30")

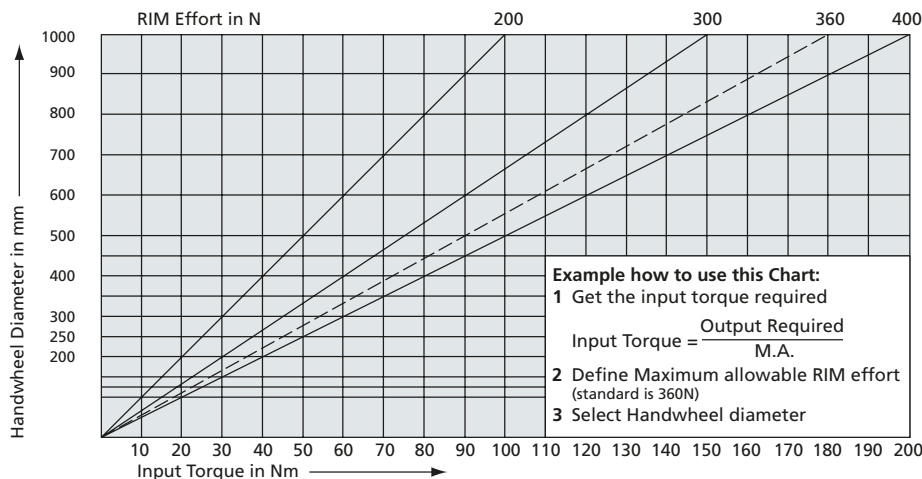

A full listing of the Rotork sales and service network is available on our website.

www.rotork.com

Rotork Gears UK
 tel +44 (0)113 256 7922
 email sales@rotorkgears.com

Corporate Headquarters
 Rotork plc
 tel +44 (0)1225 733200
 email mail@rotork.com

rotork®

Electric Actuators and Control Systems
 Fluid Power Actuators and Control Systems
 Gearboxes and Gear Operators
 Precision Control and Indication
 Projects, Services and Retrofit