

# rotork® Controls

This brochure provides a comprehensive overview of the applications and associated functions available with Rotork Q actuators - comprising Q Standard and Q Pak actuators.

The watertight 'Q' Range actuators have been designed using Rotork's world proven reliability in combination with the latest technology.

They provide a simple, cost-effective way of controlling small quarter-turn valves and dampers. Designed to meet industry's need for a compact and reliable watertight actuator where an IP68 (NEMA 6) enclosure is required. The 'Q' Range is a single-phase electric actuator which is available in two versions, both with the Rotork 'double-sealed' IP68 enclosure.

The Q-standard version is suitable for simple open/close duties where on/off control is required. This is achieved without the need for reversing contactors, giving simplified wiring.

The designs of the motor and limit switch mechanism ensure combined ease of setting and reliability in use.

The Q-pak version benefits from the addition of a specially designed control interface module which enables it to operate from a wide variety of remote control signals and provides status monitoring outputs.



## Q Range

**Watertight Single-Phase Electric  
Quarter-turn Actuators for  
part-turn valves and dampers**

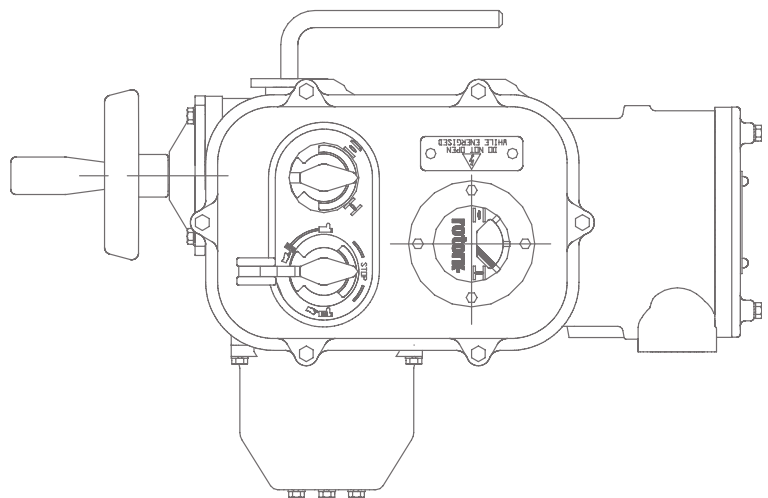

**Redefining Flow Control**

## Performance Summary

### Mechanical Data

Model	Electrical Supply (Volts)	90° Travel time (sec)		Torque†	Mounting base designation to		Maximum stem acceptance	
		50 Hz	60 Hz	Nm (lbsft)	ISO5211 (imperial)		mm (ins)	
					Standard	Optional	Bore/Keyway	A/F Square
Q100	220, 240	27, 18, 9	23, 15, 8	135	F05	F07	22*	16*
				(100)	(FA05)	(FA07)	( <sup>13</sup> / <sub>16</sub> *)	( <sup>5</sup> / <sub>8</sub> *)
	110, 115, 120	27, 18, 9	23, 15, 8	135	F05	F07	22*	16*
				(100)	(FA05)	(FA07)	( <sup>13</sup> / <sub>16</sub> *)	( <sup>5</sup> / <sub>8</sub> *)
Q300	220, 240	54, 36, 18	45, 30, 15	406	F10	F07	42**	30**
				(300)	(FA10)	(FA07)	(1 <sup>5</sup> / <sub>8</sub> )	(1 <sup>1</sup> / <sub>8</sub> )
	110, 115, 120	54, 36, 18	45, 30, 15	406	F10	F07	42**	30**
				(300)	(FA10)	(FA07)	(1 <sup>5</sup> / <sub>8</sub> )	(1 <sup>1</sup> / <sub>8</sub> **)

Q100/Q300 handwheel turns: 15

† Torque rating is maximum torque. Switch setting is in both directions.  
Torque output is adjustable from 30% to 100% of rated torque

Drive sleeves are normally supplied blank for machining by valve supplier

\* Maximum stem acceptance for both Q100 F05/FA05 and F07/FA07 bases

\*\* These dimensions apply to F10/FA10 base. With Q300 F07/FA07 base, max. acceptance is 28 mm bore or 20 mm A/F square hole.

### Electrical Data

Model	Electrical Supply (Volts)	Travel time (sec)		Starting Current (Amps)	Run Current (Amps)	Nominal (kW)	Power Factor
		50 Hz	60 Hz				
Q100	110, 115, 120	27	23	2.7	2.6	0.07	0.99
		18	15	3.2	2.3	0.10	0.97
		9	8	7.0	4.9	0.21	0.90
	220, 240	27	23	1.35	1.3	0.07	0.99
		18	15	1.65	1.2	0.10	0.95
		9	8	3.6	2.6	0.21	0.90
Q300	110, 115, 120	54	45	2.5	1.8	0.08	0.98
		36	30	6.0	3.1	0.14	0.95
		18	15	8.6	5.3	0.27	0.90
	220, 240	54	45	1.4	1.0	0.08	0.98
		36	30	2.9	1.6	0.14	0.95
		18	15	4.7	2.6	0.27	0.90

Motor poles

6

4

2

---

## Q Standard Specification

### Enclosure

Watertight to IEC529, IP68 (suitable for submersion under 3 metres head of water for 48 hours) NEMA 4 and 6. Even when the terminal cover is removed, the electrical compartment is protected to a level of IP67 from ingress of dirt and moisture.

### Temperature

The 'Q' Range has been designed for use in ambient temperatures from -30 to +70 °C.

### Vibration

The actuator can withstand plant induced vibration of 0.5g over a frequency range of 10 to 200 Hz and seismic vibration of 1g in a frequency range of 0.2 to 33 Hz. Structural integrity is maintained with a seismic vibration of up to 6g.

### Performance

Output torque available from 30 lbs.ft (40 Nm).

### Power Supply

The 'Q' Range of actuators is available as standard for use on the following single phase electrical supplies:

50 Hz-110 V, 220 V, 240 V

60 Hz-110 V, 115 V, 120 V, 127 V, 220 V and 240 V.

Other voltages can be supplied to special order. A tolerance of  $\pm 10\%$  applies to the above voltages. The motor is S2 rated for a 20% duty cycle according to IEC 34.2.

### Construction

The gearcase and all housings are diecast aluminium to BS1490. The main gearcase and motor housings are to grade LM4 with the remainder being LM24.



*Local control selectors*

### Output Drive

Easily removable blank, steel drive bush suitable for machining by customer to suit valve stem.

### Gearing

Double reduction worm and wheel with steel worm and aluminium bronze worm wheel. The second stage worm and wheel is self locking to ensure that the output cannot be back driven by valve reaction forces.

### Switches

Torque-limit and auxiliary limit switches are provided as detailed below and have the following electrical ratings on inductive loads:

110/240 VAC 15 A

110 VDC 0.25 A

50 VDC 2.5 A

24 VDC 3 A



*Torque switch setting*

### Torque-Limit Switches

One each for open and close ends of travel with normally closed contacts. Torque measurement is derived from the self locking output worm and wheel gearing, which avoids torque switch reset on the de-energization of the motor and its associated 'hammering' phenomenon.



*Auxilliary limit switch setting*

### Auxilliary Limit Switches

One auxiliary limit switch with a change over contact is provided for each direction of travel.

---

### Motor

A single-phase squirrel cage capacitor run, class F insulated induction motor is fitted. The motor is protected from overload by a thermostat.

### Local Indication

A mechanical, continuous position indicator is provided on the electrical compartment cover.

### Mounting

All flange mountings are in accordance with ISO5211. As an alternative, they are available with UNC thread holes. See page 2.

### Manual Operation

A handwheel is provided for manual operation, which is engaged by a padlockable hand/auto selection lever arranged for power preference. When engaged, the handwheel drives the second wormshaft. At no time can the handwheel be driven by the motor.



*Mechanical stop adjustment*

### Mechanical Stops

Externally adjustable mechanical stops are provided with a setting range of 80° to 100° of output movement. The setting of these provides travel limitation for both electrical and manual operation.

### Conduit Entries

Two off M32 or two off 1 inch ASA NPT.

### Q-Standard – Optional Extras

Two auxiliary limit switches each independently adjustable to any pointing of valve travel.

12 watt anti-condensation heater to suit motor supply voltage. Integrally mounted open/close and local/stop/remote selectors.

1 watt potentiometer for remote valve position indication. Externally powered 4-20 mA Current Position Transmitter (CPT).

## Q Pak Specification

The Q-pak comprises all the features of the Q-standard, as described above, with the addition of the control interface module.

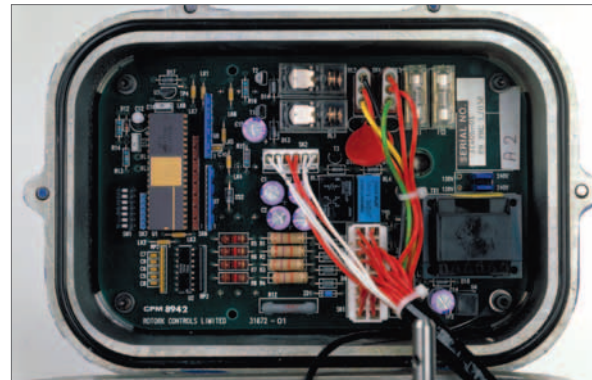

*Control interface module*

### Control Interface Module

This module incorporates a deep cover which houses a printed circuit board with logic circuits, control switches and a transformer. The cover carries open/close and local/stop/remote selectors. The logic circuits allow either internally or externally fed remote controls. Other facilities include: motor running indication, monitor relay and emergency shut down (ESD) facility.

### Q-Pak - Optional Extras

With the addition of Rotork manufactured cards the Q Pak actuator options include:

- Folomatic proportional control
- Internally powered Current Position Transmitter
- Bus Control Systems

### Bus Control Systems



The Rotork Pakscan system is capable of controlling and monitoring up to 240 field devices (actuators or other devices) using a master station connected by serial or ethernet to a DCS. A local HMI, which has a full colour integral display, shows the status of all the field devices, the current state of the communications ports, system alarms and diagnostic information, plus actuator control and set up facilities. Remote access to the asset management features are available via the built in web pages as well as the status, diagnostic, set up and control facilities provided by the local HMI.



In addition to being fully compatible with Rotork Pakscan, the Q Pak actuators can be seamlessly integrated into many other fieldbus digital control systems, such as Profibus, Foundation Fieldbus, DeviceNet and Modbus.



# rotork®

## Controls

### Inside the Q Range Actuator

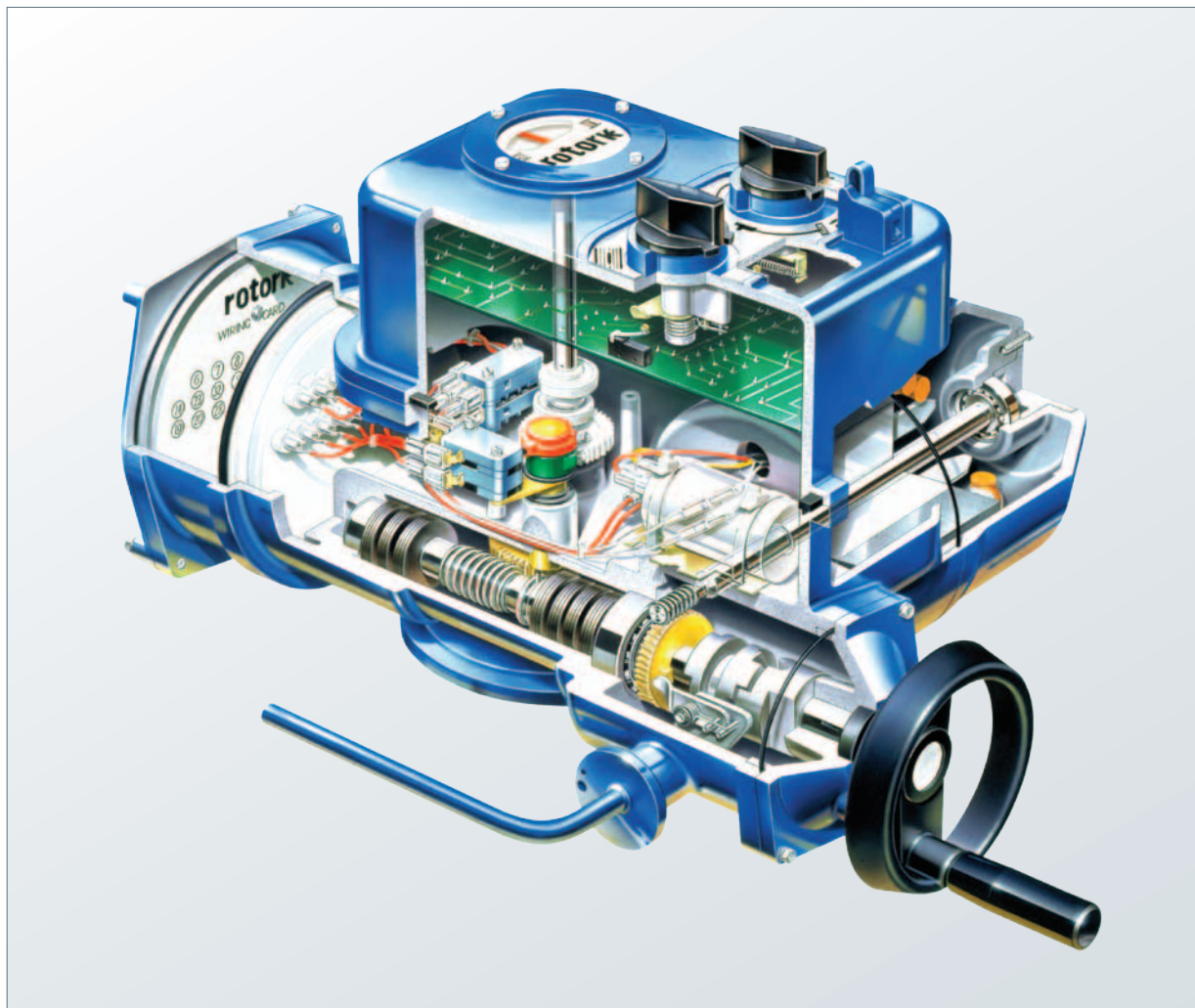

#### Features

- Reliability of single-phase squirrel cage motors.
- Simple remote control for basic applications.
- Rugged compact double-sealed watertight enclosure providing environmental protection during plant construction and cabling.
- Positive travel limitation by externally adjustable mechanical stops.
- Simple action auxiliary switch setting.
- Declutchable handwheel with padlockable hand/auto selector arranged for power preference.
- Self locking electrical and manual drive.
- Q-pak version gives compatibility with standard Rotork control and monitoring configurations.





A full listing of our worldwide sales and service network is available on our website.

[www.rotork.com](http://www.rotork.com)

*UK*

Rotork plc

*tel* +44 (0)1225 733200

*fax* +44 (0)1225 333467

*email* [mail@rotork.com](mailto:mail@rotork.com)

*USA*

Rotork Controls Inc.

*tel* +1 (585) 247 2304

*fax* +1 (585) 247 2308

*email* [info@rotork.com](mailto:info@rotork.com)

**Controls**

Electric Actuators and Control Systems

**Fluid Systems**

Fluid Power Actuators and Control Systems

**Gears**

Gearboxes and Gear Operators

**Site Services**

Projects, Services and Retrofit