

rotork®

Keeping the World Flowing
for Future Generations

IQ SIL option

IQ actuators for use in applications up to SIL 3



sira
CERTIFICATION

cass

Reliability in critical flow control applications



› Reliable operation when it matters

Assured reliability for critical applications and environments. Whether used infrequently or continuously, Rotork products will operate reliably and efficiently.

› Quality-driven global manufacturing

We offer products that have been designed with over 60 years of industry and application knowledge.

Our research and development ensures cutting edge products are available for multiple applications across multiple industries.

› Customer focused service and worldwide support

Rotork solve customer challenges and develop new solutions that are tailored to the needs of our clients.

We offer dedicated, expert service and support from initial inquiry, to product installation, to long-term after sales care.

› Low cost of ownership

Long-term reliability prolongs service life.

Rotork helps to reduce long-term cost of ownership and provides greater efficiency to process and plant.

IQ SIL option

Section	Page	Section	Page
Rotork	2	Advanced IQ features for SIL applications	7
Available 3 rd generation IQ SIL actuators	4	Typical remote control circuit diagram	9
Safety features	5	IQ remote control circuitry for SIL applications	10
IQ SIL reliability data for SIL applications	6		



Comprehensive product range serving multiple industries

Rotork products offer improved efficiency, assured safety and environmental protection across sectors such as the Power, Oil & Gas, Water & Wastewater, HVAC, Marine, Mining, Pulp & Paper, Food & Beverage, Pharmaceutical and Chemical sectors.

Market leaders and technical innovators

We have been the recognised market leader in flow control for over 60 years.

Our customers rely upon Rotork for innovative solutions to safely manage the flow of liquids, gases and powders.

Global presence, local service

We are a global company with local support.

Manufacturing sites, service centres and sales offices throughout the world provide unrivalled customer services, fast delivery and ongoing, accessible support.

Environmental Social and Governance is at the heart of our business

We have a range of policies in place that support our performance across environmental, social and governance topics. The majority of our policies are publicly available.

Rotork IQ actuators, including the SIL Safety Function Control Module option, are SIRA certified for use in SIL 2 safety applications using a 1 out of 1 actuated valve configuration (1oo1). Safety functions are “Stayput” and “Move to Limit”. **Where SIL 3 is required, IQ SIL may be used in a 1oo2 actuated valve configuration (redundant mode).**

For the types shown below there is no restriction on actuator size or speed. Refer to publication PUB002-038 for actuator sizes, speeds and torque performance details.

Due to the strict design and implementation requirements necessary, IQ SIL option is limited to the actuator type, power supply and duty rating displayed in the table below. For more information on control and monitoring options available with the IQ SIL option, refer to pages 7 and 8.

- › Suitable for use in safety systems up to SIL 2/3
- › As standard, IQ has the ability to stayput in a SIL 2 safety system
- › IQ SIL option allows a 'Move to Limit' safety function
- › Partial stroke capabilities
- › Full datalogger available
- › Supported by Rotork
- › Externally certified
- › Supported by full reliability data
- › Complements Rotork's range of electro-hydraulic spring-return actuators
- › For part-turn applications the IQT has the ability to stayput in safety systems up to SIL 2

Operation

The SIL option replaces the standard IQ control board to provide redundant control in order to carry out the specified safety function. In addition, electro-mechanical and mechanical component reliability has been assessed and quantified, meeting reliability requirements of SIL 1/2/3 applications.

A safety function status relay provides indication of the actuator's safety function ability to complete. Status is also duplicated locally on the actuator display.

In order to meet the requirements of SIL as certified by SIRA, IQ SIL actuators must be installed, commissioned, operated and maintained/proof tested in accordance with the safety manual publication PUB002-057.

Safety Functions

The two safety functions applicable to valve actuators are:

Safety Function 1 (SF1) – Stayput (High Demand)

The actuator shall not move without a valid SF1 command signal. If an internal failure is detected the actuator will give an alarm signal.

In order to meet the requirements of SIL 2 for Safety Function 1 the actuator must be controlled for opening and closing using two input signals; SF1 and a control command from a remote input or a network command. If the SF1 signal is not present, the actuator will not move. If the SF1 signal is removed while in operation, the actuator will stop. Safety Function 1 can be configured for operation in local control mode in addition to remote operation.

Safety Function 2 (SF2) – Move to Limit (Low Demand)

If an SF2 signal is active, the actuator will perform the commissioned SF2 action (open, close). If an internal failure is detected the actuator will give an alarm signal.

For Safety Function 2, a single, maintained SF2 signal derived from a normally closed contact (break to move to limit) is required. SF2 operation will override any existing remote open or close signal while applied. Safety Function 2 can be configured for operation in local and/or stop mode in addition to remote mode.

Combined Safety Functions 1 & 2 – Stayput + Move to Limit

To stayput as per Safety Function 1 or perform the commissioned SF2 action as per Safety Function 2. Safety Function 1 or Safety Function 2 can be set as the priority action. Safety function operation can be configured for local and/or stop in addition to remote mode.

Safety Functions

There are two different safety functions which the actuators can perform – Safety Function 1 (Stayput) and Safety Function 2 (Move to Limit).

Safety Function 1 (Stayput)

This can be used to prevent the actuator from responding to spurious remote control signals, or to ensure that, in the case of emergency, the actuator will not move.

- With IQ mk3 actuators this is a high demand safety function
- High Demand means that the safety function can be performed at any time, without the need for proof testing

Safety Function 2 (Move to Limit)

This can be configured to perform an Open or Close action. This will cause the actuator to move to the configured end-of-travel limit.

- This is a low demand safety function
- End-of-travel seating action can be configured for Torque* or Limit

*When seating on Torque, the actuator will override torque protection mid-travel. Once past the electrical limit, the actuator will seat on the user configured torque value. (Default – 40%).

Certification

The IQ mk3 valve actuator (certified by CSA-Sira: FSP15001) has been assessed and certified by CSA Group UK (formerly SIRA Test & Certification) against the requirements of IEC61508:2010 up to SIL 2 (1oo1) and SIL 3 (1oo2).

The certification has been issued considering the availability of a partial proof test function (known as ‘powered operation’). The PFD & SIL have been calculated using the formula shown below.

$$PFD_{pvst} = \left[DCF \times \lambda_{DD} \left(MTTR + \frac{T_{pvst}}{2} \right) + (1 - DCF) \times \lambda_{DU} \times \frac{T_{pti}}{2} \right] \times (1 - PFD_{avg_em}) + PFD_{avg0} \times PFD_{avg_em}$$

Fig. 1. Formula for calculating PFD and SIL.

Constant	Variable
Diagnostic Coverage Factor (DCF)	Probability of Failure on Demand (No PVST)
Dangerous Undetected Failure Rate (λ_{DU})	Proof Test Interval (T_{pti})
Dangerous Detected Failure Rate (λ_{DD})	Powered Operation Interval (T_{pvst})
Probability of Failure on Demand for Module performing PVST (PFD_{avg_em})	Mean Time To Repair (MTTR)

The constants are fixed parameters for which the values can be found in the SIL Certificate. The variables can be defined by the end user to meet the requirements of their specific application.

Powered operation

Powered operation can be used to improve PFD values if necessary.

Powered operation is any verified movement of the actuator, following a valid Local or Remote command, in the Open and Close direction. Powered operation can be verified locally or remotely.

- Local powered operations must be verified at the actuator through visual observation of movement
- Remote powered operations can be verified by using SIL Relay indication

Example – Actuator configured for a Close SF2 action

If the actuator receives a valid REMOTE CLOSE command followed by a REMOTE OPEN command, an energised SIL Relay will confirm that the actuator has moved in the correct direction, therefore verifying a Powered Operation has been completed. If the actuator receives a valid LOCAL CLOSE command the operator can verify movement visually, thus confirming the Power Operation has been completed.

The list of faults detected by the SIL Relay is below:

- Removing power to the actuator
- Internal electronics error
- SIL Config Mode – If the actuator is in commissioning mode
- SIL Deactivated – If the actuator has not been set up
- EEPROM Error – Faulty EEPROM hardware has been detected
- Thermostat Trip detected
- SIL Wrong Direction – If the actuator tried to do an ESD but detected that the direction is wrong
- Configuration error detected
- Stalled - For SF2 only. No movement detected by the actuator, following a valid remote or local command

The reliability data provided is applicable to the complete actuator, up to and including the actuator output drive assembly. It does not include the valve, valve drive components or second stage gearboxes. The integrity/reliability of the electrical power supply and user derived control signals are not included in the actuator reliability assessment.

The reliability data in the tables below assume powered operation (PO) has been carried out at least once every six months. Refer to PUB002-057 or SIRA certificate FSP 150001 for full reliability data information.

Safety Function 1: Stayput	Symbol	IQ10 - 18	IQ19 - 25	IQ35	IQ40	IQ70 - 95
Subsystem type		Type B	Type B	Type B	Type B	Type B
Hardware fault tolerance	hFT	0	0	0	0	0
Safe diagnosed failures	λ_{SD}	0	0	0	0	0
Safe undiagnosed failures	λ_{SU}	1.15E-05	1.15E-05	1.15E-05	9.60E-06	9.60E-06
Dangerous diagnosed failures	λ_{DD}	0	0	0	0	0
Dangerous undiagnosed failures	λ_{DU}	4.00E-07	5.00E-07	6.00E-07	4.40E-07	4.70E-07
Probability of failure per hour	pFH	5.00E-07	5.00E-07	5.00E-07	4.60E-07	4.60E-07
Safe failure fraction	sFF	96%	96%	96%	95%	95%
SIL capability		SIL 2	SIL 2	SIL 2	SIL 2	SIL 2

Safety Function 2: Move to limit	Symbol	IQ10 - 18	IQ19 - 25	IQ35	IQ40	IQ70 - 95
Proof test interval (hours)	t1	8760	8760	8760	8760	8760
Mean time to repair	mTTR	24	24	24	24	24
Subsystem type		Type B	Type B	Type B	Type B	Type B
Hardware fault tolerance	HFT	0	0	0	0	0
Safe diagnosed failures	λ_{SD}	1.98E-05	8.24E-06	8.24E-06	8.18E-06	8.18E-06
Safe undiagnosed failures	λ_{SU}	6.62E-05	6.41E-05	6.45E-05	6.35E-05	6.25E-05
Dangerous diagnosed failures	λ_{DD}	7.34E-07	7.68E-07	7.68E-07	7.84E-07	7.84E-07
Dangerous undiagnosed failures	λ_{DU}	1.70E-06	1.96E-06	1.88E-06	1.77E-06	2.51E-06
Diagnostic coverage	dC	30%	28%	29%	31%	37%
Safe failure fraction	sFF	98%	97%	97%	98%	97%
Probability of failure on demand	pFD	4.00E-03	4.60E-03	4.40E-03	4.10E-03	5.80E-02
SIL capability (low demand mode)		SIL 2	SIL 2	SIL 2	SIL 2	SIL 2

Certificate reference: Size 1 = IQ10, IQ12, IQ18 Size 2 = IQ19, IQ20, IQ25 Size 3 = IQ35 Size 4 = IQ40, IQ70 Size 5 = IQ90, IQ91, IQ95

Actuator selection and sizing

The selection of actuator type and size is dependent on the valve type (multi-turn or part-turn) and the required operating forces (torque and/or thrust). Actuator performance data is provided in publication PUB002-038. An online actuator sizing guide is available at www.rotork.com. Contact Rotork for further help or advice.

The following conditions will be applied:

- Rotork will size the actuator based on the supplied valve data. No additional safety factors will be added unless expressly requested
- The valve or valve drive components must be capable of safely withstanding the supplied actuator stall torque and/or developed thrust at stall torque. For design purposes, stall torque must be considered to be at least two times supplied actuator/actuator-gearbox combination rated torque
- Under operation to move to limit (Safety Function 2), torque protection at the set value is active for valve seating unless set to stop on position. If the valve is obstructed mid travel during stroke, the actuator will apply up to stall torque in an attempt to complete the safety function. In the unlikely event of position sensor failure, stall torque may be developed at any position (obstructed / seating)

Actuator power

The actuator electrical power supply integrity does not fall within the scope of the actuator reliability data. Users must ensure the integrity of the actuator power supply meets the requirements of the target SIL for the SIS.

Actuator control

All IQ network and analogue control options are available with the SIL option. Process control and reporting will be available as normal, however to invoke Safety Function 1 or 2 hardwired control inputs must be used and have priority. This arrangement allows the actuator to be under control of the basic process control system (BPCS) for normal operation by network, analogue or hardwired control, while also integrating it with the safety instrumented system (SIS) using hardwired signals to prevent operation or for priority safety shutdown.

With a network or analogue control option fitted or with basic hardwired control, for Safety Function 1 withdrawal of the SF1 input signal will prevent operation. In the case of Safety Function 2, removal of the SF2 hardwired signal will cause the actuator to carry out the SF2 action as configured. Refer to example IQ mk3 circuit diagram 700B0000 and control connection drawing RWS120 on the following pages. Safety Function 1 and 2 can be combined and user configured as to which has priority.

In order to meet the requirements of SIL 2 for Safety Function 1, the actuator must be controlled for opening and closing using two input signals; SF1 and a control command from a remote input or a network command. If the SF1 signal is not present, the actuator will not move. If the SF1 signal is removed while in operation, the actuator will stop.

For Safety Function 2, a single, maintained SF2 signal derived from a normally closed contact (break to Move to Limit) is required. SF2 operation will override any existing remote open or close signal while applied.

Safety Function 1 and Safety Function 2 can be configured to override local control and stop mode.



Modbus®

HART
COMMUNICATION PROTOCOL

Pakscan™



Actuator indication

Fault status relay

The SIL option includes a status relay contact providing remote indication that the system has detected an invalid or fault condition and has performed the safety function, or, the safety function cannot be applied or could be overridden. The actuator LCD display also provides fault status indication.

Indication contacts

The actuator has four configurable contacts, S1 to S4 available for indication including open and closed position limit indication and intermediate position indication (configurable). An optional four configurable contacts, S5 to S8 can be provided if an additional relay indication is required.

A full list of available functions is provided in publication PUB002-040.

Monitor relay

The monitor relay will indicate one or more of the following conditions:

- Loss of one or more of the power supply phases
- Loss of control circuitry supply
- Actuator selected for local control
- Thermostat tripped
- Local / remote control pushbutton set to Local stop

Analogue 4-20 mA position indication

The Current Position Transmitter (CPT) provides a non-contacting internally or externally fed 4-20 mA analogue signal proportional to valve position. Selectable for minimum signal corresponding to fully Closed or fully Open position with automatic zero and span setting.

NOTE: Indication outputs S1 to S8, Monitor Relay and the CPT analogue position signal do not fall within the scope of the actuator reliability assessment and therefore should not form part of the SIS.

User must ensure the integrity of indication meets the requirements of the SIL target for the SIS. If necessary, limit position indication should be derived from devices external to the actuator and driven directly from the valve obdurator.



Typical remote control circuit diagram

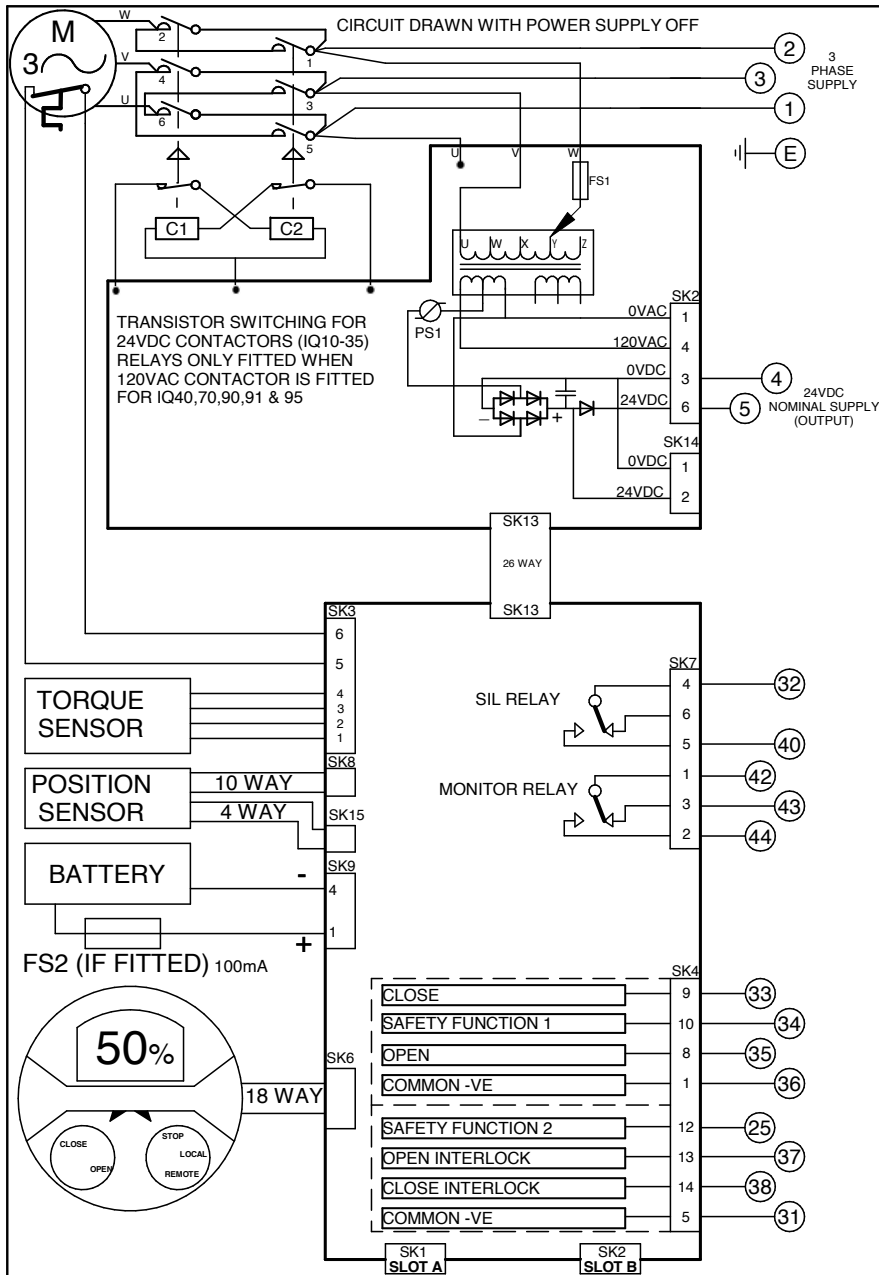

FOR TYPICAL REMOTE CONTROL DETAILS, SEE DOCUMENT
RWS120

TRANSFORMER TAPPING OPTIONS	
Tap	Nominal 50/60Hz
TYPE 1	
W	220/230
X	380/400
Y	400,415/420
Z	440/460
FUSE FS 1=250mA ANTI-S URGE	
TYPE 2	
W	346/380
X	480/500
Y	240/240
Z	550/575
FUSE FS 1=250mA ANTI-S URGE	
TYPE 3	
X	660/660-690
Y	690/-
FUSE FS 1=150mA ANTI-S URGE	

REFER TO SHEET 2 FOR NOTES & OPTION PCB'S IF FITTED

SIL NOTES (Superseeding Sheet 2 Notes)

Independently Certified to IEC61508-2 (2010) as an element suitable for use in safety related systems up to and including SIL 2 (1oo1) and SIL 3 (1oo2). Must be installed, commissioned, tested and operated fully in accordance with the Safety Manual. Refer to SIL Safety Manual - PUB002-057

SIL STAYPUT (Safety Function 1): The control signal must be applied to terminal 34 before an open or closed control signal will operate the actuator. This is a high demand safety function, actuator will not move spuriously.

If the safety function is configured for SIL STAYPUT only, terminal 25 will be a standard (Non-SIL) ESD terminal, as per PUB002-040.

SIL MOVE TO LIMIT (Safety Function 2): The control signal must be removed to terminal 25 to cause the actuator to move to the configured end of travel position (Open or Close limit). This is not a maintained input, SF2 control signal must be removed for the duration of operation to the configured limit position. This is a low demand safety function.

If the safety function is configured for SIL MOVE TO LIMIT (SF2) ONLY, terminal 34 will be a standard Stop/Maintain input in accordance with PUB002-041.

Safety Function 1 + Safety Function 2: Where both safety functions are required, the priority and functions must be configured in accordance with the SIL Safety Manual - PUB002-057. The common for SF1 (terminal 36) and SF2 (terminal 31) are independent allowing the control signal to be derived from separate, independent systems. If required, where signals are derived from the same system, the commons can be linked together. SF1 and SF2 Signals must be within the range 16-60VDC, positive supply switched only.

Iss	Date	Chkd	Revision Details	www.rotork.com		IQ + SIL			
4	061216	PMJ	EXTRA NOTE ADDED FOR TERMINAL 34.	ROTORK CONTROLS LTD BATH, BA1 3JQ ENGLAND Tel:01225-733200	ROTORK CONTROLS INC ROCHESTER NY 14624, USA Tel:585-247-2304	Drawn by: PMJ Date : 030614 Base WD: 700B0000 Job No : -- MI No : --	Circuit Diagram Number 700B0000	Issue No 5	Sheet 1 of 2
5	160217	PMJ	SIL NOTES PAGE 1 ADDED						

IQ remote control circuitry for SIL applications – DC voltage only

To meet the requirements of SIRA certificate FSP 15001 for SIL applications the following DC remote control connections must be made. The safety integrity assessment for the remote control circuits is the responsibility of others and does not form part of the actuator assessment.

Before putting the actuator into service, it must be installed and commissioned in accordance with IQ mk3 SIL safety manual publication PUB002-057.

The *Bluetooth*® wireless setting tool enables configuration of all actuator settings.

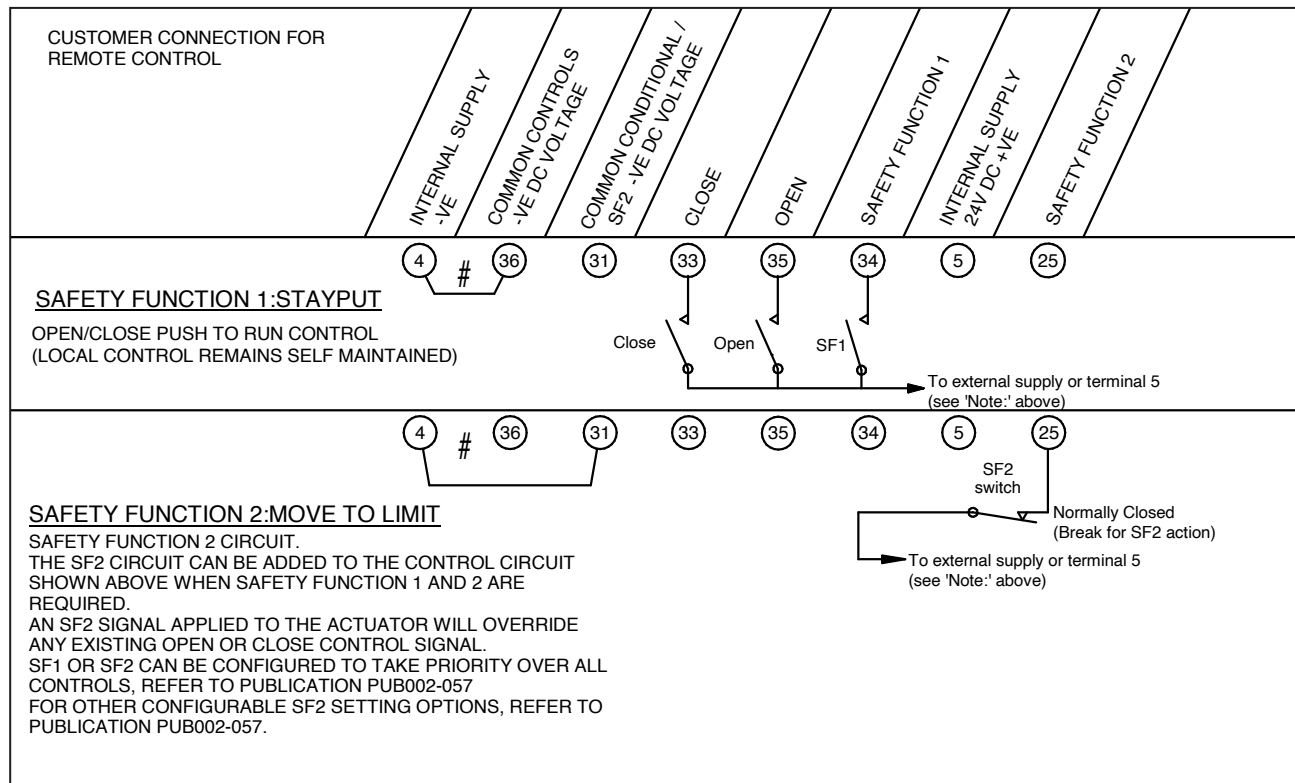

Note:

Independently Certified to IEC61508-2 (2010) as an element suitable for use in safety related systems up to and including SIL 2 (1001) and SIL 3 (1002). Must be installed, commissioned, tested and operated fully in accordance with the Safety Manual. Refer to SIL Safety Manual - PUB002-110.

SIL STAYPUT (Safety Function 1): The control signal must be applied to terminal 34 before an open or closed control signal will operate the actuator. This is a high demand safety function, actuator will not move spuriously. The SIL STAYPUT function is not applicable for LOCAL control.

Internally supplied:

Fit links '#' as shown and connect remote control contacts to internal supply on terminal 5.

Externally supplied:

Connect control contacts to external supply DC +VE. Connect supply DC -VE to terminals 36 & 31.

rotork®



www.rotork.com

A full listing of our worldwide sales and service network is available on our website.

Rotork plc
Brassmill Lane, Bath, UK
tel +44 (0)1225 733200
email mail@rotork.com

PUB002-104-00
Issue 10/23

As part of a process of on-going product development, Rotork reserves the right to amend and change specifications without prior notice. Published data may be subject to change. For the very latest version release, visit our website at www.rotork.com

The name Rotork is a registered trademark. Rotork recognises all registered trademarks. The Bluetooth® word mark and logos are registered trademarks owned by Bluetooth SIG, Inc. and any use of such marks by Rotork is under license. Published and produced in the UK by Rotork. POLTG1123