

## Keeping the World Flowing for Future Generations

### IQ19 optimised for penstock, sluice gates and gate valve applications

The IQ19 complements our existing IQ range and is optimised for larger stem acceptance. More commonly used in the water industry, the IQ19 is designed primarily for use with penstocks, sluice gates or gate valves with oversized stems.

- Torque output 135 Nm (100 lbf.ft)
- Rising stem acceptance up to 51 mm / 2" diameter
- 18-72 rpm @ 50 Hz, 21-86 rpm @ 60 Hz

#### Benefits of the 3<sup>rd</sup> Generation IQ

##### Unrivalled Industry Leading Reliability

- Continuous position tracking at all times, even without power
- On power loss, graphical interface, remote indication and datalogger are maintained and accessible
- Extended life and mounting in any orientation with oil bath lubrication
- Water ingress protection, not reliant on terminal cover or cable gland sealing – double-sealed to IP66/68 7 m for 72 hours
- Built-in protection by using independent torque and position sensing
- Safe emergency, motor-independent, handwheel operation available at all times
- Certified for safety applications (SIL2/3)
- Drive bush bearings sealed for life – no maintenance required
- Backed by Rotork global support

##### Simple, Secure Commissioning and Configuration

- Rapid and secure commissioning and configuration even without power
- Non-intrusive setting in any environmental conditions – no cover removal required, using Rotork intrinsically safe setting tool
- Easy installation and valve maintenance using detachable thrust bases
- Remote operation, configuration and commissioning up to 100 m from actuator with Remote Hand Station



## IQ Range - IQ19

#### Asset Management and Preventative Maintenance

- Real time valve and actuator performance information viewable on screen
- Safe and secure data download via non-intrusive and intrinsically safe setting tool
- Field upgradeable and configurable control and indication options using setting tool
- Compatible with *Pakscan* P4 digital control and monitoring system plus all leading field bus networks
- Detailed trend analysis, diagnostics and datalogger available, on-screen, downloadable and via *Pakscan* Plus network

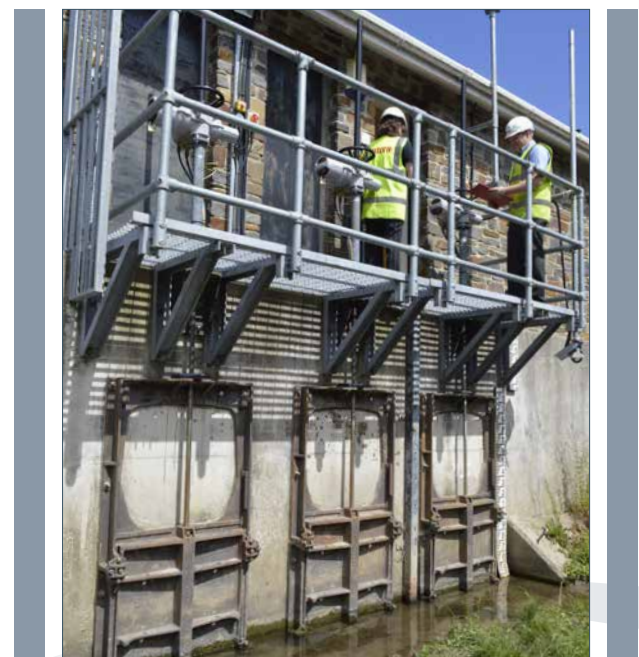

### IQ19 Stem Acceptance

Removable aluminum bronze drive couplings supplied for machining. Maximum stem acceptance diameter:

ISO 5210 Coupling: A Rising	mm	51
	inches	2

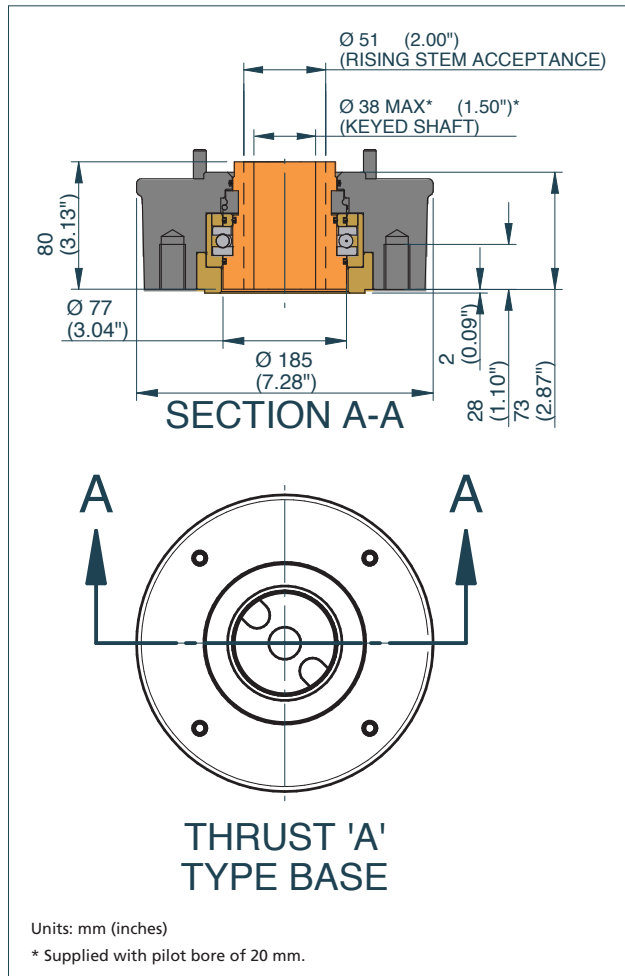

### IQ19 Performance

RPM	50 Hz	18	24	36	48	72
	60 Hz	21	29	43	57	86
Torque	Nm	135	135	135	135	135
	lbf.ft	100	100	100	100	100

For additional torque values please see the full IQ range brochure PUB002-038.

### Watertight and Hazardous Area Enclosure Certification

Through the use of non-intrusive commissioning and adjustment using the Rotork *Bluetooth*® Setting Tool Pro, covers never need removing and therefore the hermetic, factory-sealed enclosure protects internal components for life. The terminal compartment is sealed from other areas by the Rotork double seal, maintaining watertight integrity even during site connection.

The IQ range of actuators are built in accordance with the following standards:

#### Non-Hazardous Enclosures

IEC 60529	IP66 / IP68, 7 metres / 72 hours
NEMA (US) / CSA (Canadian)	Type 4 & 6

#### Hazardous Area Enclosures

International Standards	FM, ATEX, CSA, IECEx
-------------------------	----------------------

### IQ19 Handwheels

Standard ratio	1:1
Option ratio	13.3:1

A full listing of the Rotork sales and service network is available on our website.

[www.rotork.com](http://www.rotork.com)

Corporate Headquarters  
Rotork plc  
tel +44 (0)1225 733200  
email [mail@rotork.com](mailto:mail@rotork.com)  
USA  
Rotork Controls Inc.  
tel +1 (585) 247 2304  
email [mail@rotork.com](mailto:mail@rotork.com)

rotork®

Electric Actuators and Control Systems  
Fluid Power Actuators and Control Systems  
Gearboxes and Gear Operators  
Precision Control and Indication  
Projects, Services and Retrofit