





CHECK LIST

Checking actuator settings requires the use of  and  keys only. Displays on actuator show set values. Return to the start of the setting procedure (Position Display) by pressing  and  together. Checking may be carried out with the actuator in either Setting or Checking mode.



Until C1 (DIRECTION TO CLOSE) is displayed



Clock

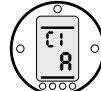

Anti-clock



To display C2 (CLOSE ACTION)



Limit

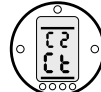

Torque



To display C3 (OPEN ACTION)



Limit

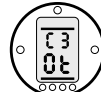

Torque



To display t C (TORQUE VALUE CLOSING)





Display shows selected torque



To display t C (TORQUE VALUE CLOSING)



Display shows selected torque

Press  and  together to return to Position Display and move valve to fully closed condition checking that closed symbol and lamp appear just as the limit of travel is reached.

Move valve to fully open position checking that open symbol and lamp appear just as the limit of travel is reached.

UK Head Office

Rotork Controls Limited
Brassmill Lane
Bath BA1 3JQ
England
Tel: +44 (0) 1225 733200
Fax: +44 (0) 1225 333467
Email: mail@rotork.co.uk

USA Head Office

Rotork Controls Inc
675 Mile Crossing Blvd
Rochester
NY 14624 USA
Tel: +1 585 328 1550
Fax: +1 585 328 5848
Email: info@rotork.com

A listing of Rotork worldwide can be found on <http://www.rotork.com>

As we are continually developing our products, the design of Rotork actuators are subject to change without notice. The name Rotork is a registered trademark



BASIC SETTING INSTRUCTIONS



Actuator Indicator Display Window

Hold setting tool directly in front of indicator window.
Range 0.5 metres (18 inches)

 Across Key

 Plus Key

 Red Local / Stop / Remote Selector.
Select to "Local"

Down Key 

Minus Key 

Enter Key 

Setting Tool

These instructions enable the actuator to be configured to suit the valve and must be carried out before electrical start up. For complete instructions see Publication E170E.



POSITION DISPLAY

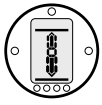

Switch on actuator power supply - select Local control. Setting may take place with display indicating closed, mid travel or open. Display will not indicate true position until position limit settings have been completed.
When using the setting tool press key until display changes

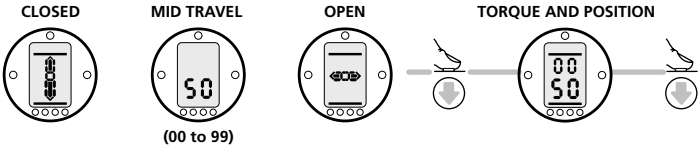

PASSWORD DISPLAY

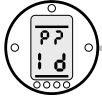

Default password is I d - do not change



Bar indicators appear confirming that setting mode has been entered. If bar indicators are not displayed, the actuator is in checking mode and settings cannot be changed.

OTHER ACTUATOR SETTINGS

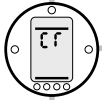

Site configuration of indication and control options (see Publication E170E)

VALVE CONTROL DISPLAY



C1 (DIRECTION TO CLOSE)

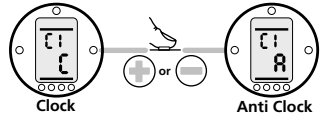

C2 (CLOSE ACTION)

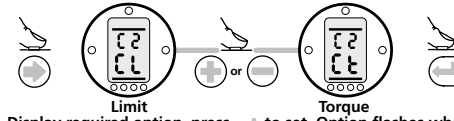

C3 (OPEN ACTION)

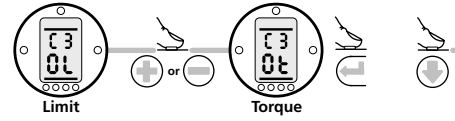

Display required option, press ← to set. Option flashes when entered.

TORQUE VALUE DISPLAYS



tC (TORQUE VALUE CLOSING)

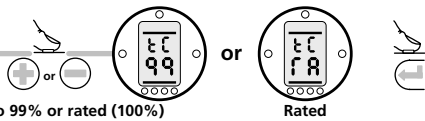

40% to 99% or rated (100%)

Rated

tO (TORQUE VALUE OPENING)

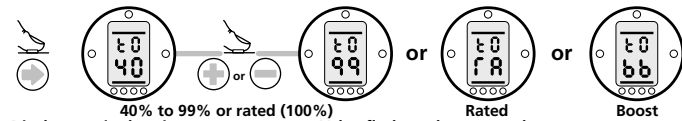

40% to 99% or rated (100%)

Rated

Boost

Display required option, press ← to set. Value flashes when entered.

TRAVEL LIMITS

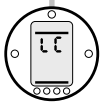

LC (LIMIT CLOSED)

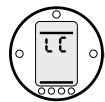

Manually operate the actuator to the fully closed position and back-off half to one turn of the actuator output.

LO (LIMIT OPEN)

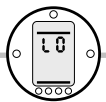

Manually operate the actuator to the fully open position and back-off half to one turn of the actuator output.

When the ← is pressed the bars will flash and the appropriate indicator lamp will be illuminated.

POSITION DISPLAY

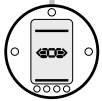

Initial actuator settings are now complete and it is possible to operate the actuator electrically.

It is possible to return to the position display from anywhere in the setting procedure by pressing ↓ and → together.

