

rotork®

Keeping the World Flowing
for Future Generations

Corrosion protection



IQ, IQT, CK and CMA range actuators

Corrosion protection for IQ, IQT, CK and CMA



IQ and IQT range actuators

The standard Rotork paint system has been developed over the past 50 years to offer suitable protection for the vast majority of actuation applications.

In certain scenarios, additional protection is required for especially arduous conditions.

The standard paint colour for IQ3 and IQ3 Pro range actuators is BS4800 00-A-05 Light Grey – 80% gloss. Base, handwheel and hand/auto lever is RAL9005 Black – 70% gloss for IQ variants and unpainted black plastic for IQT variants.

This paint protection applies to IQ, IQS, IQD, IQM, IQL, IQML, IQT, IQTM and IQTF actuators.



CK range actuators

The same proven paint system developed for IQ is applied to CK. This includes increased protection for operation in arduous environments.

The standard paint colour for CK actuators is RAL5024 Pastel Blue – 80% gloss. Handwheel and hand/auto lever is RAL9005 Black – 70% gloss.

This paint protection applies to CK, CK_R, CK_A, CK_{RA}, CK_C and CK_{RC} actuators.

Note: PX three coat offshore wet paint system is not available for CK range actuators.



CMA range actuators

The same proven paint system developed for IQ and CK is applied to CMA. This includes increased protection for operation in arduous environments.

The standard paint finish is RAL5010 (blue, polyester powder coated to Rotork specification RS237). Optional paint colours and finishes are available, please contact Rotork for details.

Unpainted units are available for OEM customers.

This paint protection applies to CML, CMR and CMQ actuators.

Note: PX three coat offshore wet paint system is not available for CMA range actuators.

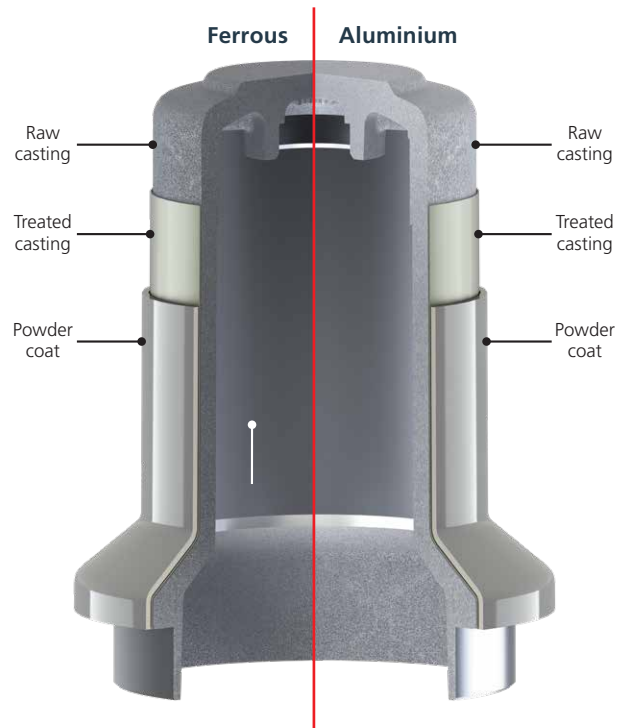

P1 – Standard paint system

Aluminium castings go through a multi-stage cleaning and chrome-free surface conversion pre-treatment process to provide an excellent surface for powder coat to be applied with strong adhesion.

The steel hand/auto lever is plated to apply a continuous, unbroken sacrificial zinc alloy layer which ensures long term corrosion protection.

The iron base is submerged in zinc phosphate solution before being cold water rinsed.

All surfaces are then coated with an architectural grade polyester powder coat with excellent exterior durability and colour retention.

P1 provides a hard coating, resistant to mechanical damage such as chips and scratches. P1 is optimised for inside or outside applications in normal onshore environments.

Overall film thickness: 100 µm

Corrosion protection for IQ, IQT, CK and CMA

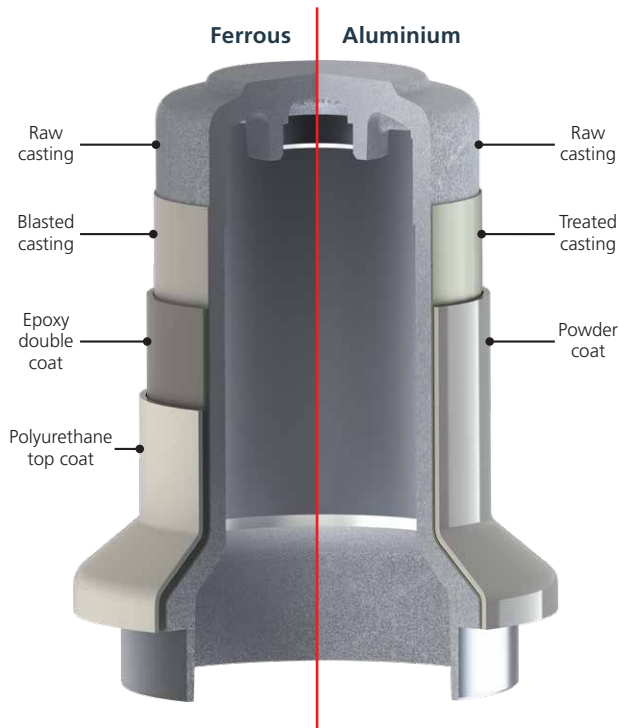

P2 – Standard paint system plus offshore coating combination

Aluminium castings receive the same treatment as P1.

The steel handwheel, hand/auto lever and iron base are coated with off-shore paint.

P2 provides cost effective improvement to corrosion protection optimised for coastal and marine applications.

Overall film thickness:

100 µm for aluminium components

320 µm for steel and iron components

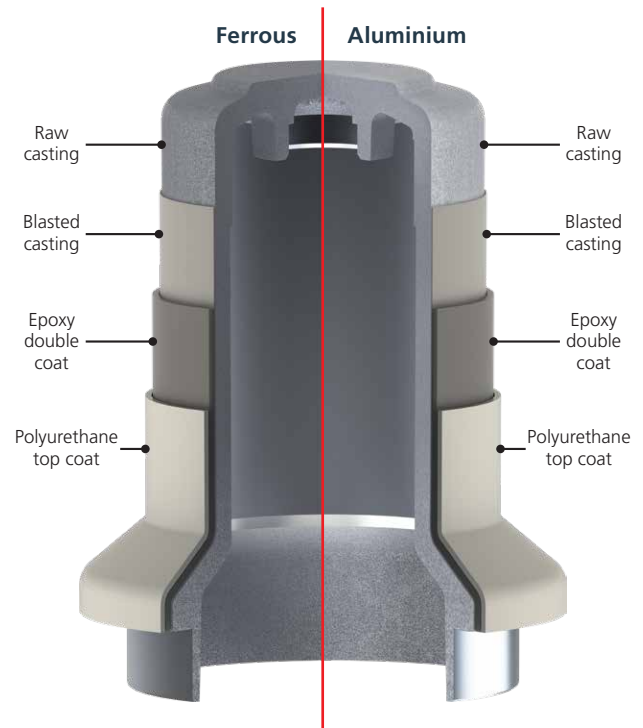

PX – Three coat offshore wet paint system (IQ and IQT range only)

All surfaces are abrasive blast cleaned before receiving two coats of high build epoxy, followed by a polyurethane top coat.

PX provides a high level of corrosion protection in harsh environments with a high durability. PX is designed for offshore and marine applications.

Overall film thickness: 320 µm

Note: PX three coat offshore wet paint system is not available for CK and CMA range actuators

Corrosion protection for IQ, IQT, CK and CMA

Below is a table showing the recommended Rotork paint system for each environment.

Corrosivity category	Durability		
	Low (2-5 years)	Medium (5-15 years)	High (>15 years)
C1	P1	P1	P1
C2	P1	P1	P1
C3	P1	P1	P1
C4	P1	P1	P2
C5-M – Marine	P1	P2	P2
C5-I – Industrial	P2	P2	PX*

* C5-I – Industrial (PX) is not available for CK and CMA range actuators.

For reference, ISO 12944-2 category definitions are shown below.

Corrosivity category	Typical environments - Exterior	Typical environments - Interior
C1	–	Heated buildings with clean atmospheres e.g. offices, shops, schools, hotels.
C2	Atmospheres with low levels of pollution. Mostly rural areas.	Unheated buildings where condensation may occur, e.g. depots, sports halls.
C3	Urban and Industrial atmospheres, moderate sulphur dioxide pollution. Coastal areas with low salinity.	Production rooms with high humidity and some air pollution, e.g. food processing plants, laundries, breweries, dairies.
C4	Industrial areas and coastal areas with moderate salinity.	Chemical plants, swimming pools, coastal ship and boatyards.
C5-M – Marine	Coastal and offshore areas with high salinity.	Buildings or areas with almost permanent condensation and with high pollution.
C5-I – Industrial	Industrial areas with high humidity and aggressive atmospheres.	Buildings or areas with almost permanent condensation and with high pollution.

For very high durability (>25 years) and CX corrosivity category please contact Rotork.

A full listing of the Rotork sales and service network is available on our website.

www.rotork.com

Corporate Headquarters

Rotork plc

tel +44 (0)1225 733200

email mail@rotork.com

rotork[®]

Electric Actuators and Control Systems

Fluid Power Actuators and Control Systems

Gearboxes and Gear Operators

Precision Control and Indication

Projects, Services and Retrofit

PUB001-023-00

Issue 09/24

As part of a process of on-going product development, Rotork reserves the right to amend and change specifications without prior notice. Published data may be subject to change. For the very latest version release, visit our website at www.rotork.com

The name Rotork is a registered trademark. Rotork recognises all registered trademarks. Published and produced in the UK by Rotork. POLTG0824