

rotork®

Keeping the World Flowing
for Future Generations

Actuator-Gearbox Combination

Installation and Maintenance Instructions

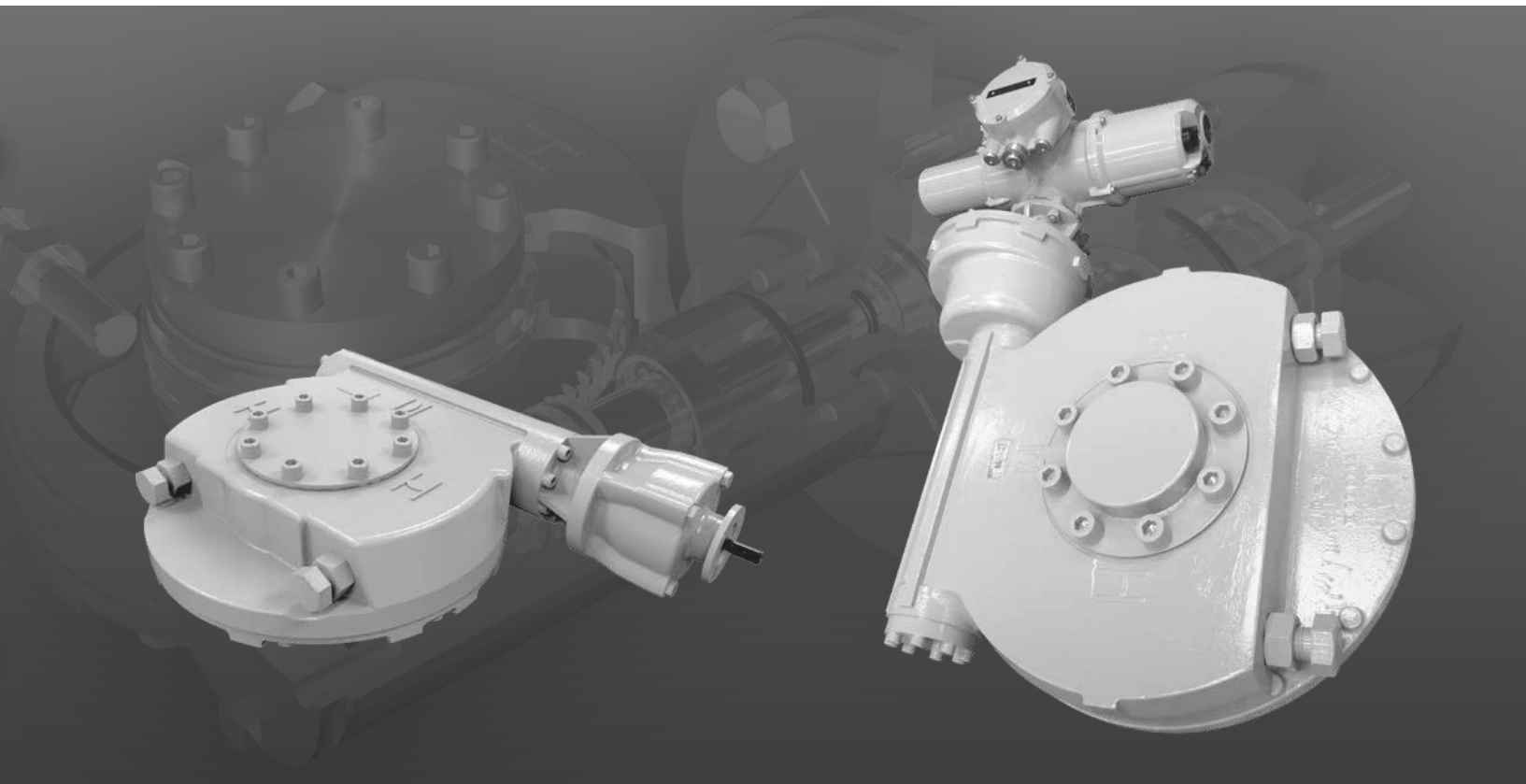

Contents

Section	Page	Section	Page
1. Introduction	3	7. Gearbox Installation IW, MOW, MTW, IB and IS ranges	7
2. Health and Safety	4	7.1 Introduction	7
3. Combination Types	5	7.2 Installation and maintenance of worm combinations	8
4. Storage	5	7.2.1 Output sleeve removal, machining and refitting	8
5. Unpacking	5	7.2.2 Mounting to the valve	9
6. Handling	6	7.2.3 Baseplate thread depths	10
		7.2.4 Setting the gearbox stops to suit the valve (IW and MOW only)	11
		7.2.5 Worm combination maintenance	11
		7.3 Installation and maintenance for multi-turn IB and IS combinations	12
		7.3.1 Output sleeve removal, machining and refitting	12
		7.3.2 Mounting to the valve	13
		7.3.3 Gearboxes IB2 to IB13 and IS2 to IS13, IS15 and IS17	14
		7.3.4 Gearboxes IB14 and IS14, IS16, and IS18-IS21	15
		7.3.5 All IB and IS Gearboxes	16
		7.3.6 Maintenance instructions for IB and IS gear operators	16
		7.4 Paint repair procedure	17
		7.5 Reference	17
		7.6 Rotork Gears ATEX Declaration of Conformity	18

1. Introduction

The electrical installation, maintenance and use of supplied equipment should be carried out in accordance with the National Legislation and Statutory Provisions relating to the safe use of this equipment applicable to the site. This instruction manual must be read in conjunction with the actuator Installation and Maintenance manual supplied with the actuator and normally located in the actuator terminal compartment during shipment.

Installation and maintenance manuals are the property of the final owner of the equipment and therefore must be retained with the actuator-gearbox combination during onward shipping.

This manual assumes that the actuator-gearbox combination has been coupled together by Rotork or its agent and is therefore supplied ready for attachment to the intended valve. It is the responsibility of the installer to satisfy themselves that the supplied combination is suitable for the intended valve in terms of, but not limited to, torque and/or thrust output and rating, mechanical loading and attachment.

For the purposes of this manual, an actuator supplied mechanically coupled to a gearbox will be referred to as a "combination".

The actuator type and gearbox type are recorded on their respective nameplates.

⚠ This manual contains important safety information. Please ensure it is thoroughly read and understood before installing, operating or maintaining the equipment.

⚠ This manual is produced to enable a competent person to install the combination. Only persons competent by virtue of their training or experience should install, maintain and repair the supplied combination.

⚠ The actuator and gearbox weights are stated on their respective nameplates. Total combination weight is the sum of the two nameplate weights.

⚠ WARNING

Combinations may present an unbalanced load.

⚠ WARNING

With respect to hand wheel operation, under no circumstances should any additional lever device such as a wheel-key or wrench be applied to the hand wheel in order to develop more force when closing or opening the valve. This may cause damage to the valve and/or gearbox or may cause the valve to become stuck in the seated/back seated position.

⚠ WARNING

Damage to protective coatings may invalidate warranty and should be correctly rectified.

Unless otherwise specified the actuator and gearbox are supplied assembled. In the case of part-turn (IW, MOW) combinations, the gearbox stops have been set to a nominal 90°. Limits for multi-turn actuator-gearbox combinations (IB, IS and MTW) are set for the specified valve turns, or where valve turns have not been specified, a nominal value.

⚠ IW and MOW gearbox stops must be re-set for the stroke of the valve after combination installation. Refer to Section 7.

2. Health and Safety

This manual is produced to enable a competent user to install, operate, adjust and inspect Rotork combinations designed for valve and damper operation. Only persons competent by virtue of their training or experience should install, maintain and repair Rotork actuators and gearboxes.

Work undertaken must be carried out in accordance with the instructions in this and any other relevant manuals. The user and those persons working on this equipment should be familiar with their responsibilities under any statutory provisions relating to the Health and Safety of their workplace. Due consideration of additional hazards should be taken when using the combination with other equipment. Should further information and guidance relating to the safe use of the Rotork products be required, it will be provided on request.

The electrical installation, maintenance and use of these combinations should be carried out in accordance with the National Legislation and Statutory Provisions relating to the safe use of this equipment, applicable to the site of installation. For the UK: Electricity at Work Regulations 1989 and the guidance given in the applicable edition of the "IEE Wiring Regulations" should be applied. Also the user should be fully aware of his duties under the Health and Safety Act 1974. For the USA: NFPA70, National Electrical Code® is applicable. Refer to supplied actuator Installation and Maintenance manual.

The mechanical installation should be carried out as outlined in this manual and also in accordance with relevant standards such as British Standard Codes of Practice. If the actuator and gearbox have nameplates indicating suitability for installation in hazardous areas then the actuator-gearbox combination may be installed in Zone 1, Zone 21, Zone 2 and Zone 22 (or Div 1 or Div 2, class I or Class II) classified hazardous area locations only. It should not be installed in hazardous area locations with an ignition temperature less than 135 °C, unless suitability for lower ignition temperatures has been indicated on the actuator and gearbox nameplates. It should only be installed in hazardous area locations compatible with the gas groups stated on the nameplate. The electrical installation, maintenance and the use of the actuator-gearbox combination should be carried out in accordance with the code of practice relevant for that particular Hazardous Area certification. No inspection or repair should be undertaken unless it conforms to the specific hazardous area certification requirements. Under no circumstances should any modification or alteration be carried out on the actuator-gearbox combination as this could invalidate the hazardous area approval certification. Access to live electrical conductors is forbidden in the hazardous area unless this is done under a special permit to work, otherwise all power should be isolated and the actuator moved to a non hazardous area for repair or attention.

WARNING: MOTOR TEMPERATURE

Under normal operation the temperature of actuator's motor cover surfaces can exceed 60 °C above ambient.

WARNING: ENCLOSURE MATERIALS

The gearbox enclosure may include cast iron, SG iron, carbon steel or stainless steel. For actuator enclosure material details, refer to the actuator installation and maintenance instructions.

The user must ensure that the operating environment and any materials surrounding the actuator cannot lead to a reduction in the safe use of, or the protection afforded by, the actuator. Where appropriate the user must ensure the actuator is suitably protected against its operating environment.

3. Combination Types

Standard combinations of actuator and gearbox ranges include the following. Other combinations may be supplied.

Combination Output Type	Gearbox Range	Actuator Range		Comments
		IQ / CK / AWT / A	IQM / CKR / M	
Quarter-turn Output	IW	✓	X	Standard 90° Worm
	MOW	X	✓	Modulating 90° Worm
Multi-turn – Thrust	IB	✓	✓	Bevel gear
	IS	✓	✓	Spur gear
Multi-turn – Non-thrust	MTW	✓	✓	Worm multi-turn, high ratio-low turns

4. Storage

If the combination cannot be installed immediately store it in a clean dry place until you are ready install on the valve.

5. Unpacking

Combinations are packed in a variety of configurations depending on size, type and quantity of the consignment.

It is the responsibility of the individual unpacking and handling the combination to carry out a risk assessment for the supplied arrangement to ensure safe working. Refer to Section 6 - Handling.

Packaging material used may include wood, cardboard, polyethylene and steel. Packaging should be recycled according to local regulations.

6. Handling

The mechanical installation should be carried out as outlined in this manual and also in accordance with relevant standards such as for the UK, HSE Safe use of lifting equipment – Lifting Operations and Lifting Equipment Regulations 1998: Approved Code of Practice and guidance.

⚠ Only trained and experienced personnel should carry out handling. At all times, safe handling must be ensured.

⚠ Each combination must be assessed to identify all risks associated with handling.

⚠ Individual weights for the actuator and gearbox are recorded on their respective nameplates/ labels.

⚠ The combination total weight is the sum of the actuator weight and the gearbox weight as recorded on their respective nameplates. See example below.

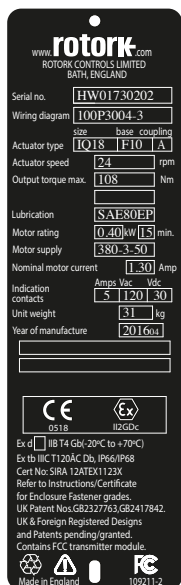

⚠ Once connected to the valve, each combination – valve assembly must be assessed on an individual basis for safe handling/lifting. Never lift the complete combination-valve assembly via the gearbox.

⚠ If it is necessary to lift the combination using lifting equipment, certified soft slings are recommended. Damage to protective coatings may invalidate warranty unless correctly rectified.

⚠ Before handling combinations comprising IB and IS gearboxes it is recommended that a temporary bolt and washer fixture be installed to prevent the IB/IS output drive sleeve assembly becoming detached. Refer to 7.3.

⚠ Slings from the gearbox alone to lift the combination is recommended but balance (combination CofG) must be assessed to ensure safe lifting.

⚠ Where the weight of the gearbox equals or exceeds that of the actuator, slinging from the actuator alone is not permissible.

⚠ Where the weight of the gearbox equals or is less than that of the actuator, slinging from the actuator alone to lift the combination is permissible but balance (combination CofG) must be assessed to ensure safe lifting.

Where it is necessary to use lifting equipment, the combination should be slung in the correct orientation to suit attachment the valve flange/shaft.

⚠ Combinations present an unbalanced load.

⚠ The combination must be fully supported until full valve shaft/stem engagement is achieved and the combination is secured to the valve flange.

⚠ Ensure the valve is fully supported and capable of accepting increased weight and change of centre of gravity resulting from the addition of the combination.

7. Gearbox Installation IW, MOW, MTW, IB and IS ranges

⚠ This manual contains important safety information. Please ensure it is thoroughly read and understood before installing the gearbox.

⚠ This manual is produced to enable a competent person to install, operate, adjust and inspect Rotork gearboxes. Only persons competent by virtue of their training or experience should install, maintain and repair Rotork gearboxes.

⚠ The gearbox weight is recorded on the packaging and on a label attached to the gearbox.

⚠ WARNING: Gearbox may present an unbalanced load.

⚠ WARNING: With respect to handwheel operation of Rotork gearboxes, under no circumstances should any additional lever device such as a wheel-key or wrench be applied to the handwheel in order to develop more force when closing or opening the valve as this may cause damage to the valve and/or gearbox or may cause the valve to become stuck in the seated/backseated position.

⚠ WARNING: Damage to protective coatings should be correctly rectified and may invalidate warranty.

7.1 Introduction

Unless otherwise specified the gearbox is supplied assembled. In the case of ¼ turn gearboxes, the gearbox stops have been set to a nominal 90° open and close position.

⚠ The IW gearbox stops must be re-set for the stroke of the valve after combination installation.

7. Gearbox Installation IW, MOW, MTW, IB and IS ranges

7.2 Installation and maintenance of worm combinations

7.2.1 Output sleeve removal, machining and refitting

Gearbox sizes IW12 to IW16 have an output which is directly machined as specified with the order. All other worm gearbox combinations have a removable output sleeve. See Item 1, Fig.1.

Fig. 1 shows the removal of the output sleeve from the gearbox. See Fig. 2 for removing the output sleeve without damaging the sealing faces.

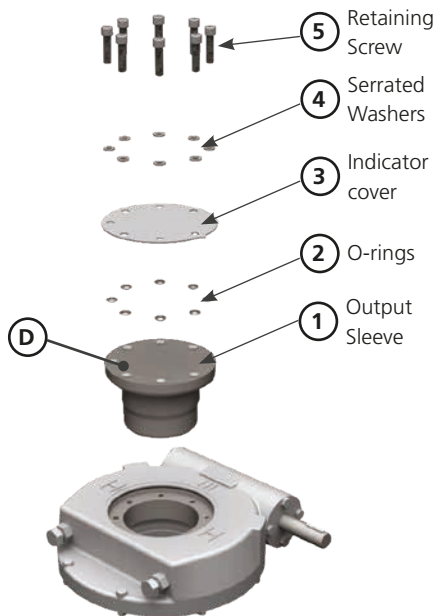

Fig. 1 - IW3-11 Output Sleeve Fitting

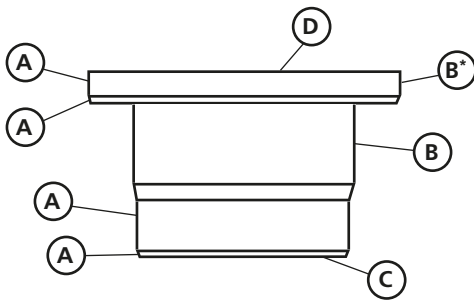

Fig. 2 - IW Output Sleeve, Important Surfaces

Important Notes for Fig. 2:

- A:** The surfaces marked 'A' are sealing or bearing faces and must not be damaged.
- B:** The surfaces marked 'B' can be used for chucking the output sleeve. *Note, this surface can only be used for chucking on MTW gearboxes. NOT IW or MOW units.

C: To remove the output sleeve from the gearbox, a force may have to be applied to the face marked 'C' of the output sleeve.

D: It is recommended to apply silicon sealant to the face marked 'D' when fitting the indicator plate.

Unless specifically requested at the ordering stage, the output sleeve will be supplied blank and must be machined to suit the valve shaft.

Referring to the item numbers in Fig. 1, the output sleeve can be easily removed from the top of the gearbox by first removing the retaining screws (5). The screws are either serrated under their heads or are fitted with serrated washers (4). Then remove the indicator/cover plate (3).

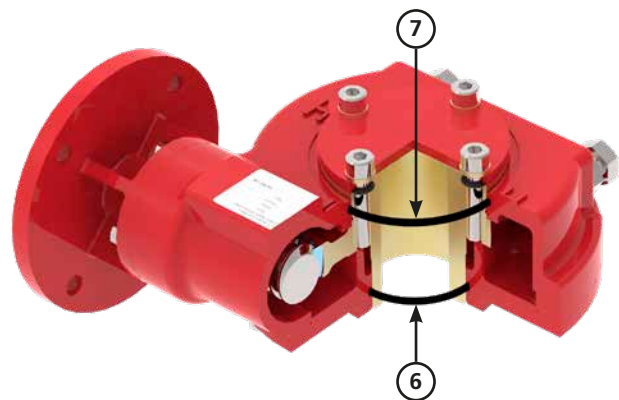

Fig. 3 - O-Ring Inspection

Referring to Fig. 3, O-rings (6) and (7) are to be inspected for damage, greased and properly seated before re-fitting the output sleeve. If the O-ring is damaged then it should be replaced prior to fitting the output sleeve.

⚠ WARNING:
Removing the retaining screws will result in the loss of control of the valve.

Referring to Fig. 1, O-rings (2) are used to seal the indicator plate, output sleeve and retaining screws. Upon final installation on the valve, screws (5) must be tightened to the correct torque figures as shown on the label on the underside of the indicator/cover plate.

Before re-fitting the output sleeve after machining, check that the surfaces marked 'A' in Fig. 2 are not damaged. Damaged surfaces can break the gearbox seals and cause water ingress or grease leakage. Applying a thin layer of grease to the faces marked 'A' will make refitting of the sleeve easier.

As detailed in Fig. 1 and Fig. 2, it is recommended that silicon sealant is applied to face 'D' to seal the indicator/cover plate to the output sleeve. Taking care not to apply sealant to the O-rings (2) or the sealing faces with the O-rings.

7. Gearbox Installation IW, MOW, MTW, IB and IS ranges

Before re-assembly, clean and de-grease the top face of the output sleeve, underside of the indicator/cover plate, and the socket head cap screws. Make a note of the tightening torque required for the output sleeve screws on the label on the underside of the indicator plate. Insert the screws and washers into the holes in the indicator/cover plate, as per Fig. 1.

It is essential to fit the two part washers the correct way round with the cam faces of the washers joining. Place the O-rings over the screw threads and against the indicator plate.

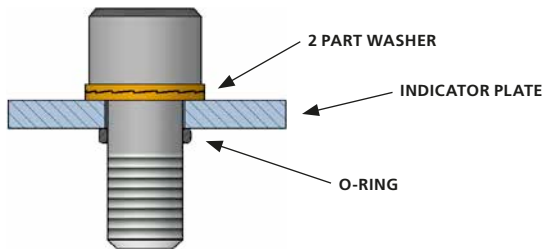

Fig. 4

Apply a thin coat of silicon sealant to the top face of the output sleeve. Place the indicator on the output sleeve, with the indicator pointer in the correct orientation if applicable. Engage each screw through the indicator and output sleeve into the tappings in the gear quadrant. Fasten the screws evenly. As the screws start to tighten, press down on the indicator plate to extrude any excess sealant. Wipe away the excess. Tighten each screw to the recommended torque previously noted.

⚠ WARNING:
It is absolutely essential to assemble and torque tighten the screws immediately after the sealant is applied to the indicator/cover plate and screws. Any delay will allow the sealant to start to cure. This will result in a flexible joint being formed between the output sleeve and indicator/cover plate. This joint would relax over time, allowing the screws to loosen.

7.2.2 Mounting to the valve

⚠ WARNING: Ensure the valve is fully supported and capable of accepting increased weight and change of centre of gravity resulting from the addition of the gearbox combination.

If the gearbox has been supplied with a handwheel, it is recommended that this be fitted to the gearbox before mounting onto the valve. This will make it easier to rotate the gearing to pick up on the valve stem, either key, flats or square.

- 1) Ensure gearbox output is in the same relative position as the valve shaft (open or closed). Gearbox output position can be moved by rotating the input shaft or turning the actuator handwheel.
- 2) Apply a ring of silicone sealant around the mounting face of the flange, the ring should be at the same radius from the shaft as the bolt holes. Apply small rings of sealant around each of the bolt holes to completely seal the faces (see Fig. 5)

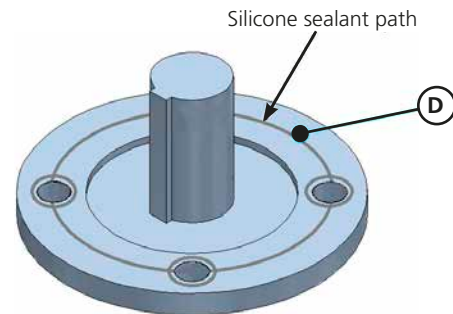

Fig. 5 - Sealing of Valve Mounting Flange

Important Note for Fig. 5:

- D: It is recommended that flanges be sealed on assembly with silicon sealant. The face marked 'D' on Fig. 5 shows where sealant can be applied to the valve mounting flange.
- 3) Align gearbox baseplate flange square and parallel to valve flange (see Fig. 5), It is recommended that flanges be sealed on assembly with silicon sealant. Grease the output sleeve and the valve shaft.
 - 4) Engage gearbox output sleeve onto the valve shaft ensuring the valve shaft keyway, square etc. is in alignment (if necessary rotate output sleeve – refer to Fig. 1)
 - 5) It is essential that the gearbox baseplate is flush with the valve bonnet flange before the mounting screws are tightened. Mounting screws or studs/nuts must be high tensile steel (grade 8.8 or higher). Firmly tighten down fixings onto the valve flange to the torque required. See Table 5 in section 7.5.

7. Gearbox Installation IW, MOW, MTW, IB and IS ranges

7.2.3 Baseplate thread depths

Gearbox	Base	Min Tap Depth	Max Drill Depth
IW3 / MOW3	F/FA10, F/FA12	18	24
	F/FA14, F/FA16	24	27
IW4 / MOW4	F/FA12, F/FA14	16	20
	F/FA16	30	34
IW5 / IW52 / MOW5	F/FA14, F/FA16	20	25
	F/FA25	16	20
	F/FA25	30	34
IW6 / IW62 / IW63 / MOW6	F/FA16, F/FA25	16	26
	F/FA16, F/FA25, F/FA30	20	26
	F/FA30	30	34
IW7 / IW72 / MOW7	F/FA16, F/FA30	24	29
	F/FA30	24	28
	F/FA35	30	40
IW8 / IW82 / MOW8	F/FA25, F/FA30, F/FA35, F/FA40	24-36	30-40
	F/FA25, F/FA30, F/FA35	30	36
	F/FA40, F/FA48	36	46
IW9 / MOW9	F/FA30, F/FA35, F/FA40	25-36	34-44
	F/FA30, F/FA35, F/FA40	25-36	46
	F/FA40, F/FA48	36	44
IW10 / MOW10	F/FA35, F/FA40	30-36	41-46
	F/FA48	36	46
	F/FA60	36	46
IW11 / IW11BB / IW115 / IW115BB / MOW11	F/FA35, F/FA40, F/FA48	30-36	44
	F/FA60	36	39
IW12 / IW13	F/FA40, F/FA48, F/FA60	38	48
	F/FA48, F/FA60	38	48

Table 1 - Baseplate Mounting Hole Details

7. Gearbox Installation IW, MOW, MTW, IB and IS ranges

7.2.4 Setting the gearbox stops to suit the valve (IW and MOW only)

This procedure should be carried out by the valvemaker/supplier and should be done when the valve opening and closing operations can be visibly checked. Once installed within the pipe the stops should not be altered without the authorisation of the valve maker/supplier.

The gearbox stops are factory set but require adjusting for optimum valve performance. If an actuator is to be used to operate the gearbox, then the mating faces between the gearbox input flange and the actuator output must be sealed prior to assembly using a ring of silicone sealant applied at the same radius as the bolt holes, a small ring of sealant should be applied around each bolt hole to completely seal the faces (see Fig. 5). The actuator limit and torque switch settings should be set up according to the actuator manufacturer's recommendations. The gearbox open & closed stop screws should then be set (see Fig. 6).

Close the valve, using the actuator where applicable. Referring to Fig. 6, use the indicator plate (3) pointer as an indication of position.

Loosen the lock nuts (7) and turn the stop screws out approximately 3 complete turns, apply a small amount of silicone sealant to the threads where the screws meet the gearcase. Operate the gearbox to the closed position and screw in stop screw (8) until it touches the gearbox quadrant (6). Rotate the screw back one turn, then tighten the lock-nut (7) to secure the stop screw. Open the valve with the actuator, and then repeat the process with the open position stop screw. If the stop screws are re-adjusted at a later date then silicone sealant must be re-applied.

Note – movement between baseplate (10) and gearcase (9) can occur when operating at near rated torques. It is recommended that regular maintenance occurs to verify baseplate screws (11) are correctly torqued.

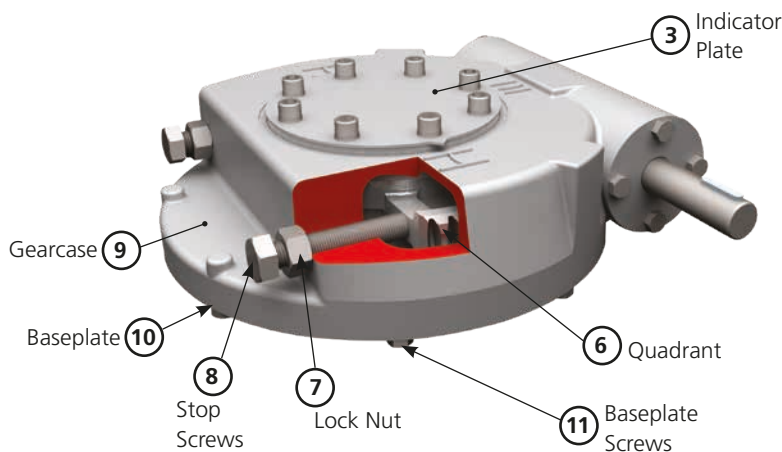

Fig. 6 - Setting Stop-Bolts

7.2.5 Worm combination maintenance

Under normal operating conditions, no maintenance is required for the gearbox. Should the valve be taken out of service for overhaul, the gearbox baseplate may be removed and the lubricant changed using one of the lubricants in Table 2. The baseplate must be sealed using silicone sealant on re-assembly, unless fitted with O-rings. These should be replaced.

Gearbox	Manufacturer	Name	Temp. Range
IW	Fuchs	Renolit CL-X2	-60 to +120 °C
MOW	Fuchs	Renolit LST 0	-20 to +120 °C
MTW	Fuchs	Renolit EPLITH 00	-10 to +120 °C

Table 2 - Recommended Lubrication for Worm Gearboxes

An equivalent extreme pressure lubricant may be used. For extreme temperature applications, please consult Rotork Gears.

7. Gearbox Installation IW, MOW, MTW, IB and IS ranges

7.3 Installation and maintenance for multi-turn IB and IS combinations

7.3.1 Output sleeve removal, machining and refitting

IB and IS range of gearboxes have a removable output sleeve. Unless specifically requested at the ordering stage, the output sleeve will be supplied blank and must be machined to suit the valve stem. Before re-fitting the output sleeve after machining, check that the surfaces marked 'A' in Fig. 7 are not damaged.

Damaged surfaces can break the gearbox seals or bearings and cause water ingress or grease leakage.

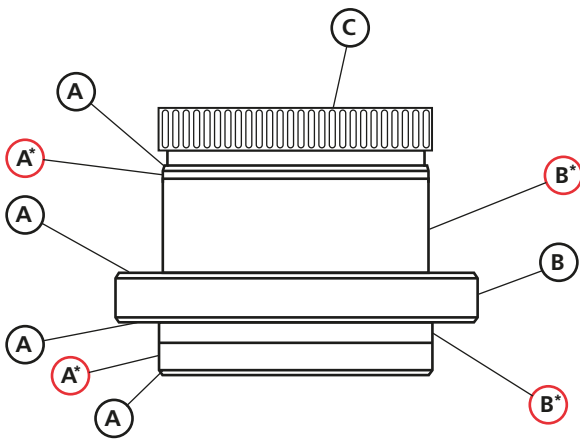

Fig. 7 - Splined Output Sleeve - Important Surfaces

Important Notes for Fig. 7:

A: The surfaces marked 'A' are sealing faces and must not be damaged.

B: The surface marked 'B' can be used for chucking the output sleeve for machining.

C: To remove the output sleeve from the gearbox, a force may have to be applied to the face marked 'C' of the output sleeve.

An anti-friction compound containing molybdenum disulphide, such as MI-Setral-9M should be applied to the faces marked with '*' and highlighted in red in Fig. 7, before inserting the output sleeve back into the gearbox. For clarification on the suitability of an anti-friction compound, please contact Rotork Gears.

Referring to Fig. 8 below, note that the output sleeve arrangement is identical for IB and IS gearboxes. The sleeve (14) can be easily removed from the gearbox by first removing the spigot ring (15) from the baseplate (16). A small force may have to be applied to the face marked 'C' in Fig. 7 to assist in removing the sleeve.

⚠ WARNING: It is imperative that the thrust bearings in the output are fitted correctly, along with the output sleeve and the spigot ring. That is, the needle thrust bearings **MUST** have a thrust washer (12) at each side of the needle race (13). A bearing / washer assembly **MUST** be fitted at each side of the output sleeve thrust shoulder.

⚠ WARNING: Bearings, Output sleeve and Valve Stem/shaft should be thoroughly greased with appropriate grease before fitting anytime they are fitted into the gearbox/valve. Note the spigot ring has an internal and external seal that should also be greased.

The IB and IS output sleeves are splined and may have to be rotated slightly to engage with the mating spline in the output gear.

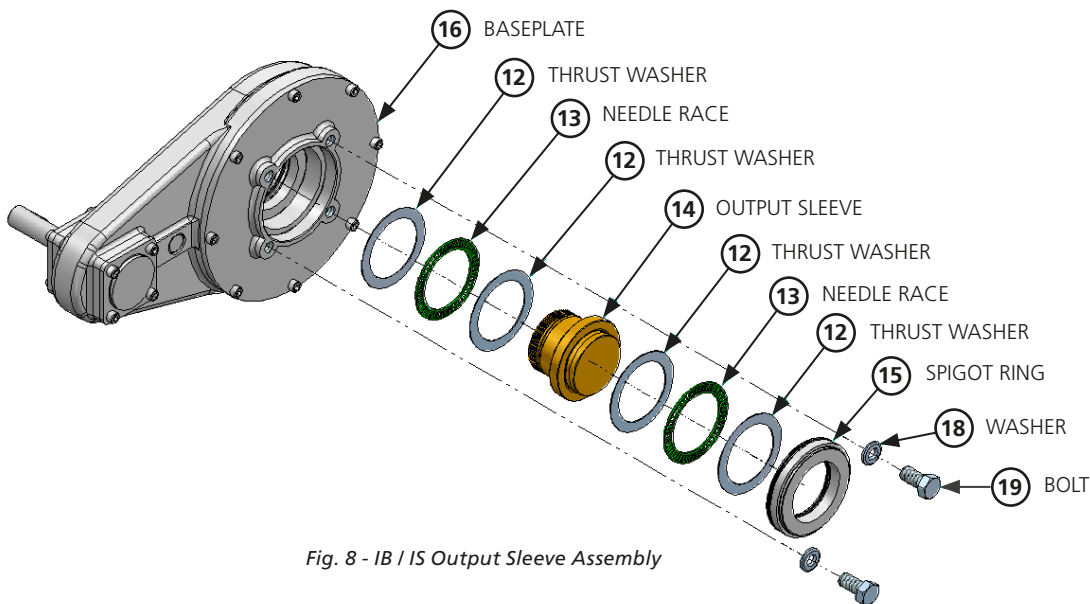

Fig. 8 - IB / IS Output Sleeve Assembly

7. Gearbox Installation IW, MOW, MTW, IB and IS ranges

⚠ WARNING – We recommend fitting a nut (19) and washer (18) fixture into the base of the gearbox as demonstrated in Fig. 8 and Fig. 9. Note that the washers must overlap the spigot ring (15). This will stop the output sleeve assembly from becoming detached from the main body. The bolts and washers are not supplied by Rotork Gears.

If the gearbox has been supplied with a handwheel, it is recommended that this be fitted to the gearbox before mounting onto the valve. This will make it easier to rotate the gearing to pick up the valve stem, key, thread or spline location.

7.3.2 Mounting to the valve

⚠ WARNING: Ensure the valve is fully supported and capable of accepting increased weight and change of centre of gravity resulting from the addition of the actuator-gearbox combination. The recommended maximum unsupported length for cover tubes is shown in table 3.

⚠ WARNING: Bearings, Output sleeve and Valve Stem/shaft should be thoroughly greased with appropriate grease before fitting into the gearbox/valve. Note the spigot ring has an internal and external seal that should also be greased.

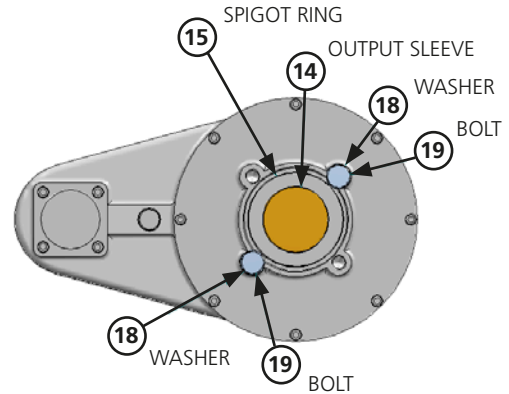

Fig. 9 - Securing Spigot Example

7. Gearbox Installation IW, MOW, MTW, IB and IS ranges

7.3.3 Gearboxes IB2 to IB13 and IS2 to IS13, IS15 and IS17

In addition to the points in Section 7.3.1, it is recommended that the machined output sleeve assembly is assembled onto the valve stem first and then the gearbox lowered onto the output sleeve assembly. See Fig. 10 and Fig. 11 for assembly details.

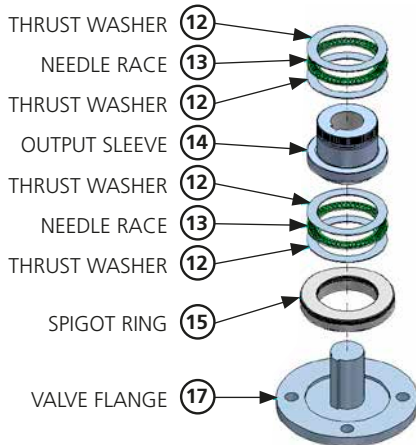

Fig. 10 - Valve Stem Assembly

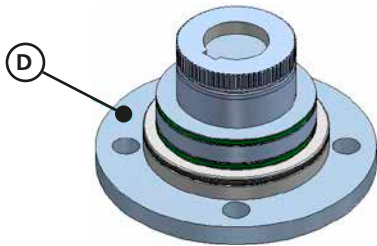

Fig. 11 - Valve Stem (Assembled)

Fit the machined output sleeve (14), thrust bearings (12 & 13) and baseplate spigot ring (15) on the valve shaft as shown in the Fig. 10. Bearings should be lubricated with the appropriate grease (see Table 4). Grease the bearings, output sleeve and valve stem. Note that the spigot ring has an internal and external seal that should also be greased.

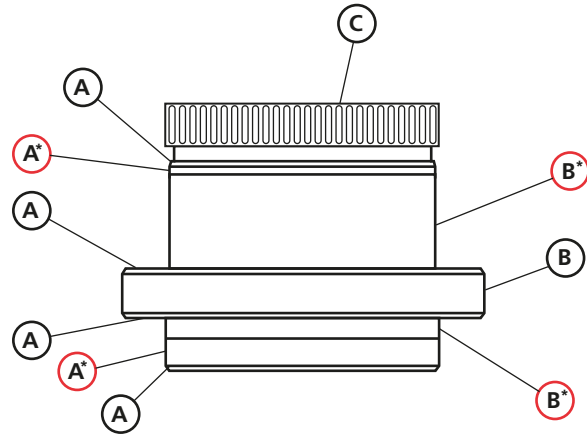

Fig. 12 - Splined Output Sleeve - Important Surfaces

Important Notes for Fig. 12:

- A:** The surfaces marked 'A' are sealing faces and must not be damaged.
- B:** The surface marked 'B' can be used for chucking the output sleeve for machining.
- C:** To remove the output sleeve from the gearbox, a force may have to be applied to the face marked 'C' of the output sleeve.

An anti-friction compound containing molybdenum disulphide, such as MI-Setral-9M should be applied to the faces marked with '*' and highlighted in red in Fig. 12, before inserting the output sleeve back into the gearbox. For clarification on the suitability of an anti-friction compound, please contact Rotork Gears.

7. Gearbox Installation IW, MOW, MTW, IB and IS ranges

7.3.4 Gearboxes IB14 and IS14, IS16, and IS18-IS21

In addition to the points in Section 7.3.1, it is recommended that the cylindrical roller bearings and machined output sleeve are assembled onto the valve stem first and then the gearbox lowered to locate on the output sleeve assembly. See Fig. 13 for assembly details:

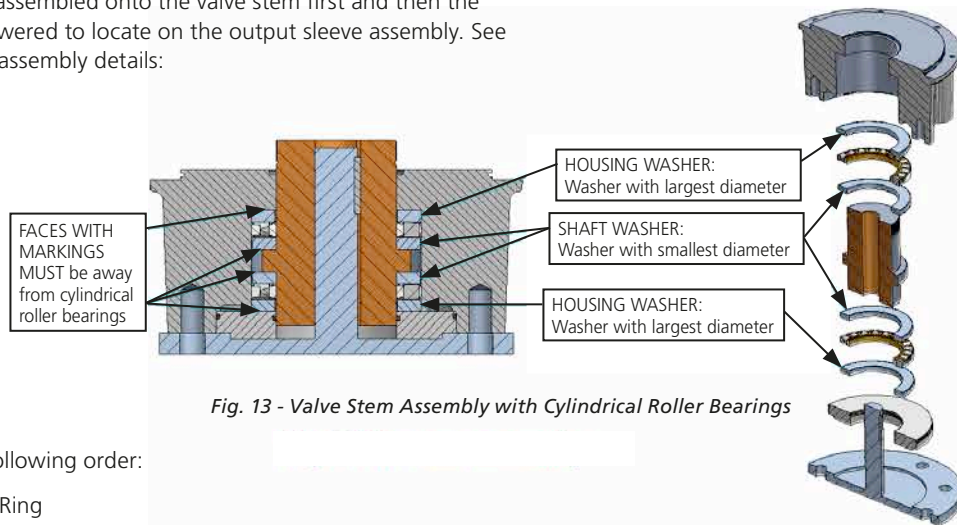

Fig. 13 - Valve Stem Assembly with Cylindrical Roller Bearings

Fit in the following order:

- Spigot Ring
- Housing Washer (Largest Outside Diameter),
- Bearing
- Shaft Washer (Smallest Outside Diameter),
- Output Sleeve
- Shaft Washer (Smallest Outside Diameter),
- Bearing
- Housing washer (Largest Outside Diameter)

The washer faces that are either chamfered or have markings MUST FACE AWAY from the bearings to decrease wear on the bearing. Bearings should be lubricated with the appropriate grease. Grease the output sleeve and valve stem. Note that the spigot ring has an internal and external seal that should also be greased.

Important Notes for Fig. 14:

- A:** The surfaces marked 'A' are sealing faces and must not be damaged.
- B:** The surface marked 'B' can be used for chucking the output sleeve for machining.
- C:** To remove the output sleeve from the gearbox, a force may have to be applied to the face marked 'C' of the output sleeve.

An anti-friction compound containing molybdenum disulphide, such as MI-Setral-9M should be applied to the faces marked with '*' and highlighted in red in Fig. 14, before inserting the output sleeve back into the gearbox. For clarification on the suitability of an anti-friction compound, please contact Rotork Gears.

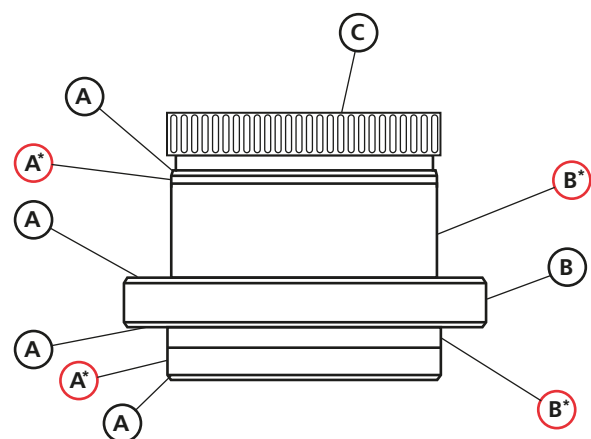

Fig. 14 - Splined Output Sleeve - Important Surfaces

7. Gearbox Installation IW, MOW, MTW, IB and IS ranges

7.3.5 All IB and IS Gearboxes

- Ensure that the gearbox baseplate is parallel to the valve flange when lowering. This will avoid jamming.
- It is recommended that a silicon sealant is used between the gearbox baseplate and the valve flange. 'D' in Fig. 5 highlights where this sealant should be applied.
- When lowering the gearbox onto the valve rotate the handwheel to ensure the gearbox internal splines correctly engage with the external splines on the output sleeve. Once engaged keep lowering the gearbox until the valve and gearbox flanges are in contact. Align mounting base holes and secure using screws or studs with a minimum tensile strength of 800 N/mm². Tighten fasteners onto the valve flange to the torque required. See Table 5 in Section 7.5.
- For rising stem valves, a cover tube must be fitted to protect the valve stem. **⚠ WARNING: Do not pack the cover tube with grease as this can lead to a pressure build up in the cover tube.** Screw or bolt the cover tube into the gearbox and seal with a suitable sealant to prevent water ingress.
- Cover tubes are extensions to the gearcase and thus, damage to the cover tube can cause damage to the gearcase. It is essential that the cover tubes are protected or supported to avoid side loads as a result of the environment or the application. See Table 3:

Gearbox	Maximum unsupported tube length
IB3 to IB5, IS4 to IS5	2.0 m (6.6 ft)
IB6 to IB7, IS6 to IS7	2.8 m (9.2 ft)
IB8 to IB9, IS8 to IS9	3.0 m (9.8 ft)
IB10 to IB14, IS10 to IS20	5.0 m (16.4 ft)

Table 3 - Maximum Unsupported Tube Lengths

- When an actuator is being installed to the input of the gearbox, it is important to apply a ring of silicone sealant between the mating faces prior to assembly (see Fig. 5).

7.3.6 Maintenance instructions for IB and IS gear operators

All gear cavities are lubricated for life with Fuchs Renolit CL-X2 grease. Under normal operating conditions, no maintenance is required for the gearbox but should the valve be taken out of service for overhaul, the gearbox baseplate may be removed and the grease changed using the following recommended lubricant. The baseplate must be sealed using silicone sealant on re-assembly, unless fitted with an O-ring. All O-rings should be renewed.

An anti-friction compound containing molybdenum disulphide, such as MI-Setral-9M should be applied to the faces marked with '*' and highlighted in red in Fig. 12, before inserting the output sleeve back into the gearbox. For clarification on the suitability of an anti-friction compound, please contact Rotork Gears.

Note: All thrust elements and bearing cavities must be re-greased and re-fitted in the correct order. The recommended lubricant is shown in Table 4.

Gearbox	Manufacturer	Name	Temp. Range
IB and IS	Fuchs	Renolit CL-X2	-60 to +120 °C

Table 4 - Recommended Lubrication for Bevel and Spur Gearboxes

An equivalent extreme pressure lubricant may be used. For extreme temperature applications, please consult the factory.

7. Gearbox Installation IW, MOW, MTW, IB and IS ranges

7.4 Paint repair procedure

If paint repair is required, the following procedure should be followed:

- Clean surface using solvent if necessary
- Rinse surface with clean fresh water to remove any foreign matter and traces of solvent
- Abrade area using wet and dry sandpaper, or power sander, feather edges of sound intact paint around damaged area by 2.5 cm
- Apply paint system as per originally applied to unit ensuring that dry film thickness (dft) limits are met and time is allowed for each coat to cure. All as per the paint manufacturer's data sheets

Ambient Conditions - No cleaning or coating application shall be undertaken if:

- The relative humidity is more than 85%
- The metal temperature is less than 3 °C above the dew point
- The ambient conditions are outside those stated in the paint manufacturer's data sheet for each coating
- Coatings shall only be applied or cured at ambient and steel temperatures above 10 °C or otherwise recommended by paint supplier.

7.5 Reference

Table 5 shows recommended tightening torques for mounting the gearbox to the valve.

Gearbox to valve fixing must conform to Material Specification ISO Class 8.8, yield strength 628 N/mm² to use Table 5 below:

Imperial Size (Hex)	Torque Nm	Torque lbf.ft
3/8"	34	25
7/16"	55	40
1/2"	83	61
9/16"	120	89
5/8"	166	122
3/4"	291	215
7/8"	469	346
1"	702	518
1 1/4"	1,403	1,035
1 1/2"	2,441	1,800

Metric Size (Hex) Nm	Torque Nm	Torque lbf.ft
M5	5	4
M6	9	6
M8	21	15
M10	41	30
M12	71	53
M16	177	131
M20	346	255
M24	598	441
M30	1,189	877
M36	2,079	1,533

Table 5 - Torque Tightening Figures

7. Gearbox Installation IW, MOW, MTW, IB and IS ranges

7.6 Rotork Gears ATEX Declaration of Conformity

Rotork Gears

Rotork UK Limited
9 Brown Lane West
Leeds
LS12 6BH
UNITED KINGDOM

Rotork Gears BV
Postbus 98
7580 AB
Losser
THE NETHERLANDS

Rotork Gears Srl
Viale Europa 17
20090 Cusago (MI) Italy
ITALY

Declares under our sole responsibility that the following ranges of gear operators:

IB	AB	DSIR
RAB	232	WG
HOB	242	
NTB	300	
IS	ILG/S	
HOS	ILG/D	
IW		
MOW		
MTW		

and the following optional gearbox mechanical equipment:

IR	ECL	DSIR
AS Lever Arm		
Travelling Nut		
Temperature Compensator		
MABD		
MPR		

and their derivatives conform to the relevant provisions of the ATEX products directive 2014/34/EU.

Assessed for group II, category 2 for gas and dust explosive atmospheres.

Compliance with the Essential Health and Safety Requirements has been assessed by reference to the following standards:

EN 13463-1 Non electrical equipment for potentially explosive atmospheres. Basic method and requirements.
EN 13463-5 Non electrical equipment for potentially explosive atmospheres. Protection by constructional safety.

Signed for and on behalf of Rotork Gears



Steve Watkins

Engineering Project Manager

rotork®



www.rotork.com

A full listing of our worldwide sales and service network is available on our website.

Rotork plc
Brassmill Lane, Bath, UK
tel +44 (0)1225 733200
email mail@rotork.com

PUB000-124-00
Issue 02/18

As part of a process of on-going product development, Rotork reserves the right to amend and change specifications without prior notice. Published data may be subject to change. For the very latest version release, visit our website at www.rotork.com

The name Rotork is a registered trademark. Rotork recognises all registered trademarks. Published and produced in the UK by Rotork. POWB1120