

1	2		3		4		5		6		7		8		
INPUT FLANGE DETAILS							MOUNTING HOLES - BOLT CIRCLE (OFF CENTRES)								
INPUT FLANGE	FLANGE O/DIA. + THICKNESS	SHAFT DIA.	RECESS DIA.	RECESS DEPTH	HOLE DETAILS (45° OFF CENTRES)	KEY DETAILS	ISO 5211 / MSS SP-101 MOUNTING OPTION	HOLE DETAILS (22.5° OFF CENTRES)	STANDARD	MIN BORE	SQ KEY MAX BORE	SQ KEY SIZE	RECT. KEY MAX BORE	RECT. KEY SIZE	SQ BORE MAX
ISO F25	Ø300 x 20 (Ø11.81" x 0.787")	Ø50.00-0.05 (Ø1.969"-0.002")	Ø200.10+0.10 (Ø7.878"+0.004")	5 (0.20")	8 x Ø16.5 ON Ø254.0 P.C. (8 x Ø0.65" ON Ø10.00" P.C.)	14x9x55 (0.55"x0.35"x2.17")	ISO F40*	8 x M36 x 36 (1.42") DEEP ON Ø406.0 (Ø15.98") P.C.	BS4235	-	-	-	178	45 x 25	□ 132.1 (5.20")
FA25							FA40*		8 x 1.25" UNC x 36 (1.42") DEEP ON Ø406.4 (Ø16.00") P.C.	ANSI B17.1	-	6.50"	1.1/2" SQ.	6.50"	
			Ø152.30+0.17 (Ø5.996"+0.007")					DIN 6885	-	-	-	178	45 x 25		

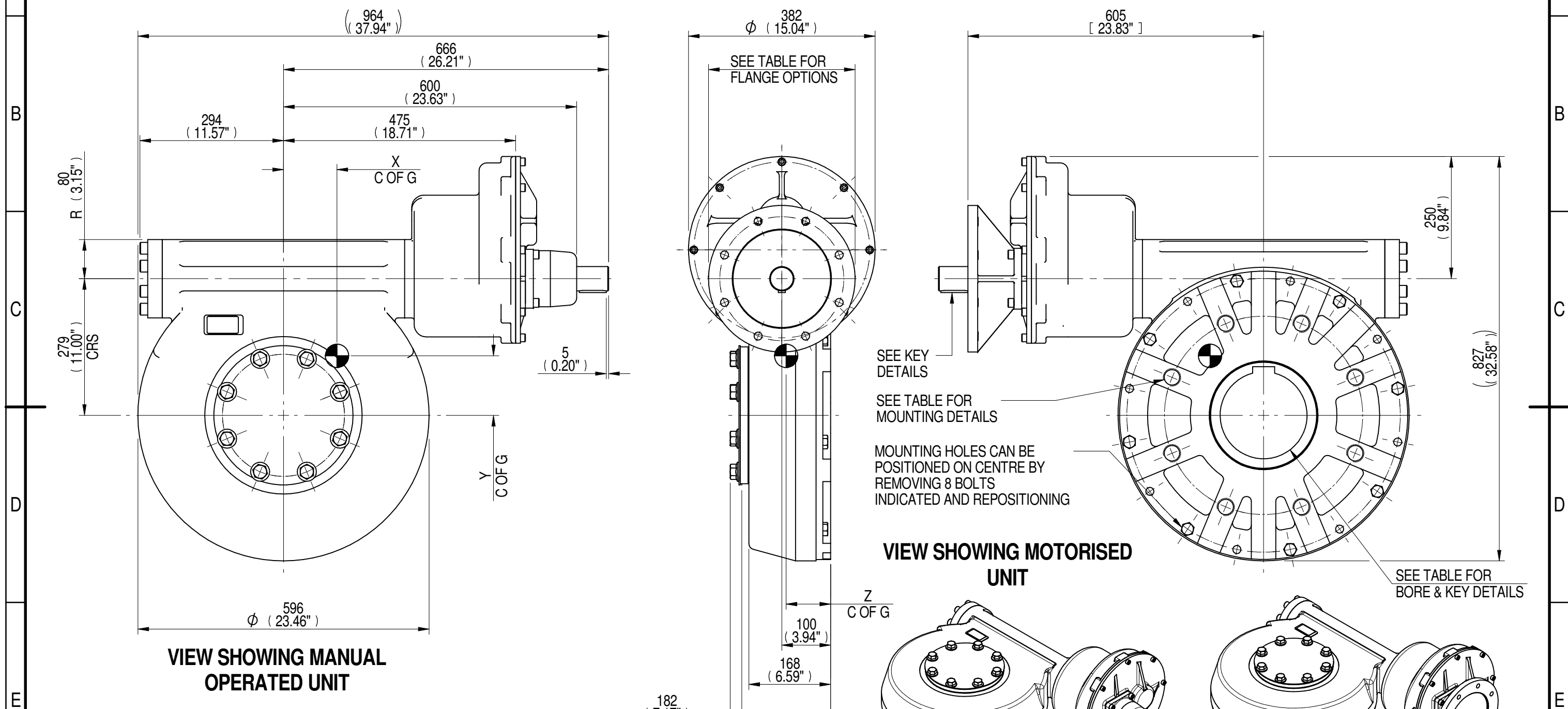

VIEW SHOWING MANUAL OPERATED UNIT

VIEW SHOWING MOTORISED UNIT

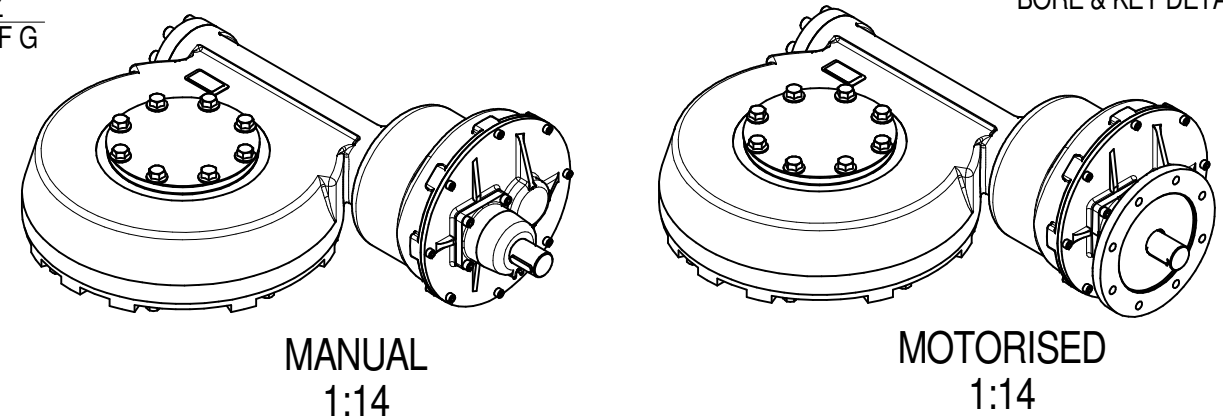

PLAN VIEW OF GEARBOX IN CLOSED POSITION SHOWING STANDARD KEYWAY POSITIONS. ALTERNATIVES AVAILABLE ON REQUEST

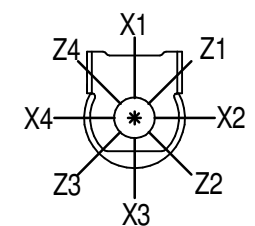

NOTES:
 1. * THREAD DEPTH DOES NOT MATCH ISO STANDARD
 2. CENTRE OF GRAVITY POSITION IS INDICATIVE FOR STANDARD BUILD WHEN IN POSITION SHOWN

RATIO	M.A.±10%	WEIGHT (Kg)	MAX OUTPUT (Nm)	MAX INPUT (Nm)	X	Y	Z
DESCRIPTION	TORQUE			CENTRE OF GRAVITY			
2940	1100	-	42030	38	-	-	-
2520	900	317	42030	47	115	125	91
2347	875	-	42030	48	-	-	-
2160	855	312	42030	49	109	121	91
1440	570	313	42030	74	109	121	91
1080	428	311	42030	98	108	121	91
960	380	313	42030	111	110	122	91

AS PART OF CONTINUOUS PRODUCT DEVELOPMENT, ALL DETAILS SUBJECT TO CHANGE WITHOUT PRIOR NOTICE. FOR UP TO DATE DETAILS PLEASE VISIT www.rotork.com

rotork Gears
 LEEDS - UK
www.rotork.com

This drawing is confidential and is the property of Rotork Gears and must not be reproduced either wholly or partly. All rights in respect of patents, designs and copyrights are reserved. ©2015

Document Type **PUBLICITY**
 Dimensions in mm

Title
MTW9 MULTI-TURN GEARBOX, 960/1080/1440/2160/2347/2520/2940:1, F25/FA25 INPUT, F40/FA40 OUTPUT

Drawing Number
PUB-MTW9IR3-F25-F40

Sheet 1 of 1 Size A3