

INPUT FLANGE DETAILS							MOUNTING HOLES - BOLT CIRCLE (OFF CENTRES)								
INPUT FLANGE	FLANGE O/DIA. + THICKNESS	SHAFT DIA.	RECESS DIA.	RECESS DEPTH	HOLE DETAILS (45° OFF CENTRES)	KEY DETAILS	ISO 5211 / MSS SP-101 MOUNTING OPTION	HOLE DETAILS (45° OFF CENTRES)	STANDARD	MIN BORE	SQ KEY MAX BORE	SQ KEY SIZE	RECT. KEY MAX BORE	RECT. KEY SIZE	SQ BORE MAX
ISO F10	Ø125 x 16 (Ø4.92" x 0.63")	Ø20.00-0.05 (Ø0.787"-0.002")	Ø70.05+0.15 (Ø2.758"+0.006")	4 (0.16")	4 x Ø10.5 ON Ø102.0 P.C. (4 x Ø0.41" ON Ø4.02" P.C.)	6x6x40 (0.24"x0.24"x1.57")	ISO F14*	4 x M16 x 16 (0.63") DEEP ON Ø140.0 (Ø5.51") P.C.	BS4235	-	-	-	76.0	22 x 14	□ 62.0 (2.44")
FA10			Ø58.70+0.15 (Ø2.311"+0.006")				FA14*		4 x 5/8" UNC x 16 (0.63") DEEP ON Ø139.7 (Ø5.50") P.C.	ANSI B17.1	-	2.75"	3/4" SQ.	3.00"	
								DIN 6885	-	-	-	76.0	22 x 14		

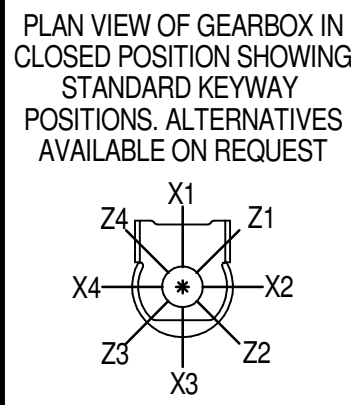
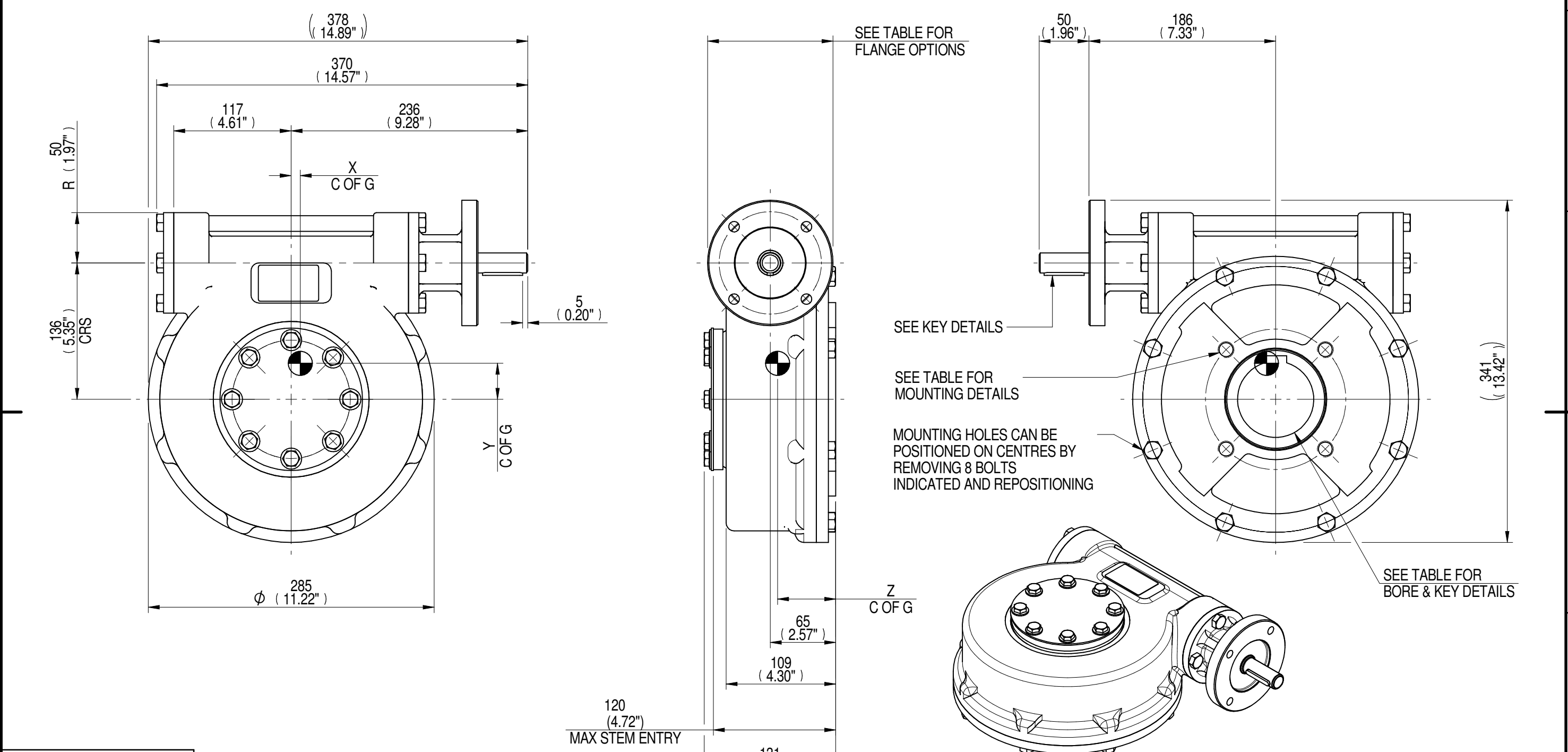

NOTES:
 1. * THREAD DEPTH DOES NOT MATCH ISO STANDARD
 2. CENTRE OF GRAVITY POSITION IS INDICATIVE FOR STANDARD BUILD WHEN IN POSITION SHOWN

70	23	38	2847	124	9	36	58
40	17	40	2847	167	9	35	58
RATIO	M.A. ± 10%	WEIGHT (Kg)	MAX OUTPUT (Nm)	MAX INPUT (Nm)	X	Y	Z
DESCRIPTION			TORQUE		CENTRE OF GRAVITY		

AS PART OF CONTINUOUS PRODUCT DEVELOPMENT, ALL DETAILS SUBJECT TO CHANGE WITHOUT PRIOR NOTICE. FOR UP TO DATE DETAILS PLEASE VISIT www.rotork.com

rotork Gears
 LEEDS - UK
www.rotork.com

This drawing is confidential and is the property of Rotork Gears and must not be reproduced either wholly or partly. All rights in respect of patents, designs and copyrights are reserved. ©2015

Document Type **PUBLICITY**
 Dimensions in mm

Title
MTW5 MULTI-TURN GEARBOX, 40/70:1 F10/FA10 INPUT, F14/FA14 OUTPUT

Drawing Number
PUB-MTW5-F10-F14

Sheet 1 of 1 Size A3

Iss. 01