

INPUT FLANGE DETAILS							MOUNTING HOLES - BOLT CIRCLE (OFF CENTRES)								
INPUT FLANGE	FLANGE O/DIA. + THICKNESS	SHAFT DIA.	RECESS DIA.	RECESS DEPTH	HOLE DETAILS (45° OFF CENTRES)	KEY DETAILS	ISO 5211 / MSS SP-101 MOUNTING OPTION	HOLE DETAILS (22.5° OFF CENTRES)	STANDARD	MIN BORE	SQ KEY MAX BORE	SQ KEY SIZE	RECT. KEY MAX BORE	RECT. KEY SIZE	SQ BORE MAX
ISO F14	Ø175 x 15 (Ø6.89" x 0.59")	Ø30.00-0.05 (Ø1.181"-0.002")	Ø100.05+0.15 (Ø3.939"+0.006")	5 (0.20")	4 x Ø16.5 ON Ø140.0 P.C. (4 x Ø0.65" ON Ø5.51" P.C.)	8x7x55 (0.31"x0.28"x2.17")	ISO F35*	8 x M30 x 36 (1.42") DEEP ON Ø356.0 (Ø14.02") P.C.	BS4235	-	-	-	178	45 x 25	□ 132.1 (5.20")
FA14			BS46						-	-	-	6.75"	1.75" x 1.25"		
		Ø95.25+0.15 (Ø3.750"+0.006")					FA35*	8 x 1" UNC x 36 (1.42") DEEP ON Ø355.6 (Ø14.00") P.C.	ANSI B17.1	-	6.50"	1.1/2" SQ.	6.50"	1.5" x 1"	
									DIN 6885	-	-	-	178	45 x 25	

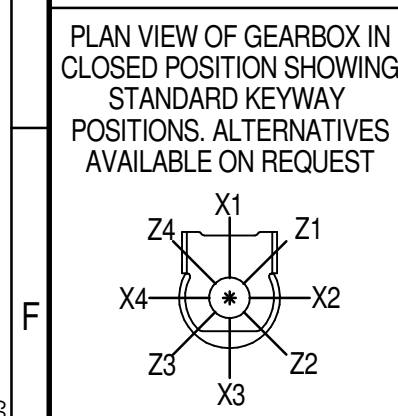
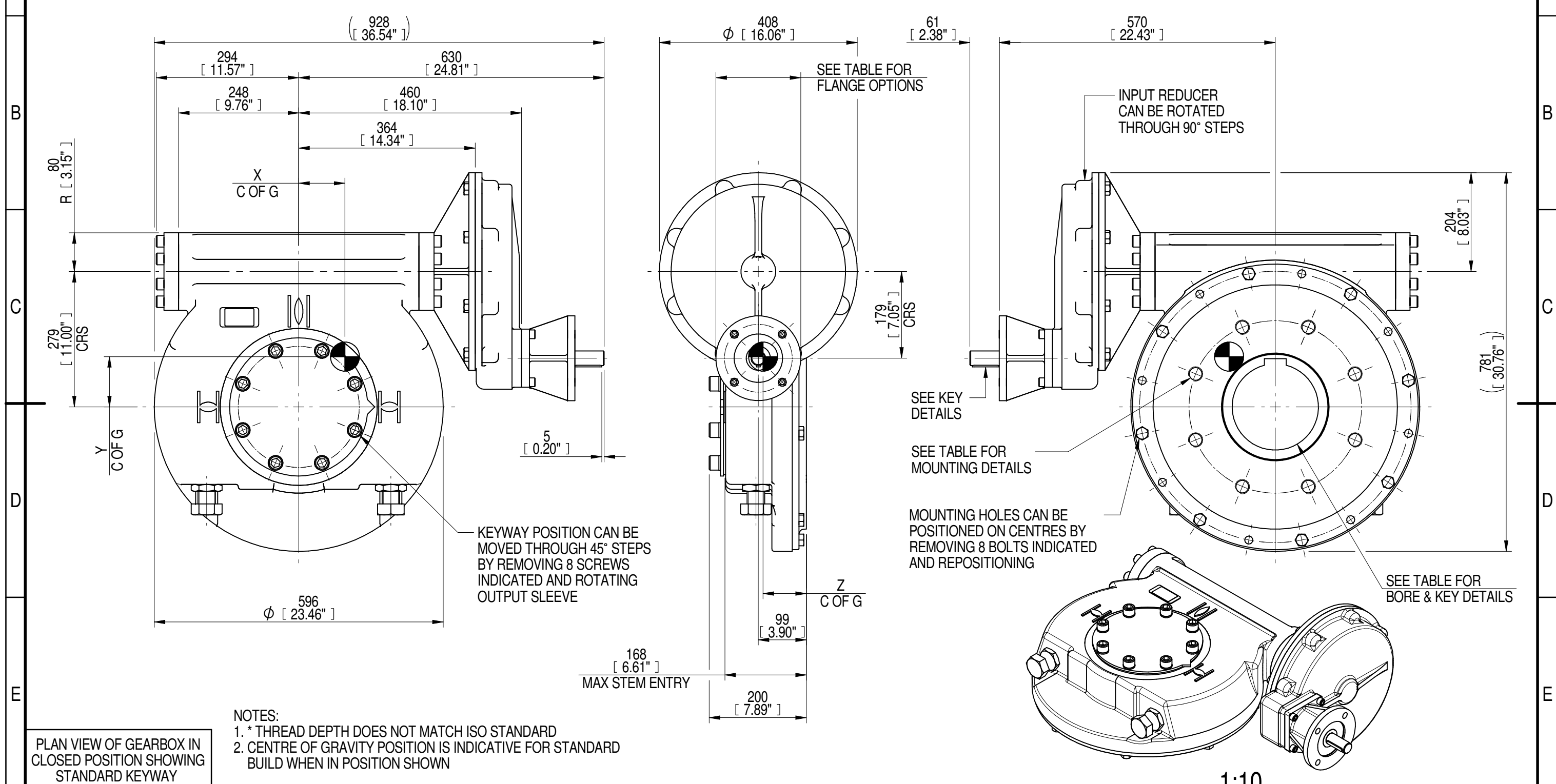

NOTES:
 1. * THREAD DEPTH DOES NOT MATCH ISO STANDARD
 2. CENTRE OF GRAVITY POSITION IS INDICATIVE FOR STANDARD BUILD WHEN IN POSITION SHOWN

RATIO	TURNS TO CLOSE	M.A. ± 10%	WEIGHT (Kg)	MAX OUTPUT (Nm)	MAX INPUT (Nm)	X	Y	Z
720	180	285	288	48809	171	98	106	89
540	135	214	286	48809	228	96	105	89
480	120	189	286	48809	258	95	104	89
360	90	142	286	48809	344	96	105	89
240	60	95	287	48809	514	96	104	89
180	45	71	286	48809	687	95	103	89
DESCRIPTION			TORQUE			CENTRE OF GRAVITY		

AS PART OF CONTINUOUS PRODUCT DEVELOPMENT, ALL DETAILS SUBJECT TO CHANGE WITHOUT PRIOR NOTICE. FOR UP TO DATE DETAILS PLEASE VISIT www.rotork.com

	This drawing is confidential and is the property of Rotork Gears and must not be reproduced either wholly or partly. All rights in respect of patents, designs and copyrights are reserved. ©2016	Document Type PUBLICITY	Title IW/MOW9 QUARTER TURN GEARBOX, 180/240/360/480/540/720 : 1, F14/ FA14 INPUT : F35/ FA35 OUTPUT
	LEEDS - UK www.rotork.com	Dimensions in mm 	Drawing Number PUB-IW9FBIR2-F14-F35
Sheet 1 of 1 Size A3			