

1	2		3		4		5		6			7		8	
INPUT FLANGE DETAILS							MOUNTING HOLES - BOLT CIRCLE (OFF CENTRES)								
INPUT FLANGE	FLANGE O/DIA. + THICKNESS	SHAFT DIA.	RECESS DIA.	RECESS DEPTH	HOLE DETAILS (45° OFF CENTRES)	KEY DETAILS	ISO 5211 / MSS SP-101 MOUNTING OPTION	HOLE DETAILS (22.5° OFF CENTRES)	STANDARD	MIN BORE	SQ KEY MAX BORE	SQ KEY SIZE	RECT. KEY MAX BORE	RECT. KEY SIZE	SQ BORE MAX
ISO F10	Ø125 x 15 (Ø4.92" x 0.59")	Ø20.00-0.05 (Ø0.787"-0.002")	Ø70.05+0.15 (Ø2.758"+0.006")	4 (0.16")	4 x Ø10.5 ON Ø102.0 P.C. (4 x Ø0.41" ON Ø4.02" P.C.)	6x6x40 (0.24"x0.24"x1.57")	ISO F35*	8 x M30 x 36 (1.42") DEEP ON Ø356.0 (Ø14.02") P.C.	BS4235	-	-	-	157	40 x 22	□ 122.9 (4.84")
FA10			ANSI B17.1						-	5.625"	1.1/2" SQ.	6.00"	1.1/2" x 1"		
	DIN 6885	-	-	-	157	40 x 22									

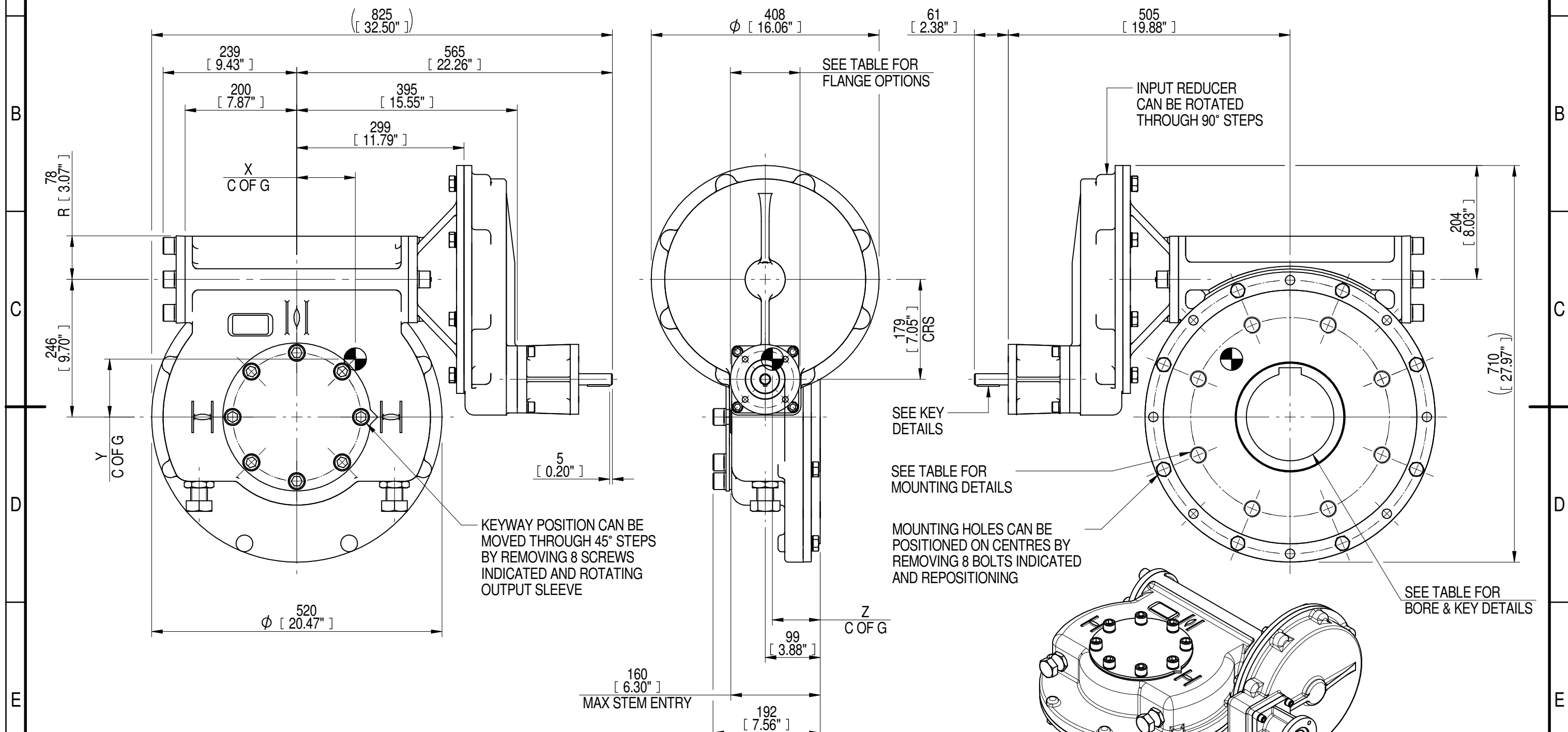

PLAN VIEW OF GEARBOX IN CLOSED POSITION SHOWING STANDARD KEYWAY POSITIONS. ALTERNATIVES AVAILABLE ON REQUEST



NOTES:  
 1. \* THREAD DEPTH DOES NOT MATCH ISO STANDARD  
 2. CENTRE OF GRAVITY POSITION IS INDICATIVE FOR STANDARD BUILD WHEN IN POSITION SHOWN

720	180	285	209	37000	130	107	105	86
540	135	214	207	37000	173	105	104	86
480	120	189	206	37000	196	105	104	86
RATIO	TURNS TO CLOSE	M.A. ± 10%	WEIGHT (Kg)	MAX OUTPUT (Nm)	MAX INPUT (Nm)	X	Y	Z
DESCRIPTION				TORQUE		CENTRE OF GRAVITY		

AS PART OF CONTINUOUS PRODUCT DEVELOPMENT, ALL DETAILS SUBJECT TO CHANGE WITHOUT PRIOR NOTICE. FOR UP TO DATE DETAILS PLEASE VISIT [www.rotork.com](http://www.rotork.com)

**rotork** Gears  
 LEEDS - UK  
[www.rotork.com](http://www.rotork.com)

This drawing is confidential and is the property of Rotork Gears and must not be reproduced either wholly or partly. All rights in respect of patents, designs and copyrights are reserved. ©2016

Document Type **PUBLICITY**  
 Dimensions in mm

Title  
**IW/MOW82 QUARTER TURN GEARBOX, 480/540/720 : 1, F10/ FA10 INPUT : F35/ FA35 OUTPUT**

Drawing Number  
**PUB-IW82FBIRL-F10-F35**

Iss. 01

Sheet 1 of 1 Size A3