

1	2		3		4		5		6				7		8
INPUT FLANGE DETAILS							MOUNTING HOLES - BOLT CIRCLE (OFF CENTRES)								
INPUT FLANGE	FLANGE O/DIA. + THICKNESS	SHAFT DIA.	RECESS DIA.	RECESS DEPTH	HOLE DETAILS (45° OFF CENTRES)	KEY DETAILS	ISO 5211 / MSS SP-101 MOUNTING OPTION	HOLE DETAILS (22.5° OFF CENTRES)	STANDARD	MIN BORE	SQ KEY MAX BORE	SQ KEY SIZE	RECT. KEY MAX BORE	RECT. KEY SIZE	SQ BORE MAX
ISO F14	Ø175 x 15 (Ø8.89" x 0.59")	Ø20.00-0.05 (Ø0.787"-0.002")	Ø100.05+0.15 (Ø3.939"+0.006")	5 (0.20")	4 x Ø16.5 ON Ø140.0 P.C. (4 x Ø0.65" ON Ø5.51" P.C.)	6x6x40 (0.24"x0.24"x1.57")	ISO F25*	8 x M16 x 16 (0.63") DEEP ON Ø254.0 (Ø10.00") P.C.	BS4235	-	-	-	102	28 x 16	□ 83.3 (3.28")
FA14			BS46						-	3.625"	1" SQ.	3.75"	1" x 3/4"		
	ANSI B17.1	-	3.75"	7/8" SQ.	3.875"	1" x 3/4"									
	DIN 6885	-	-	-	102	28 x 16									

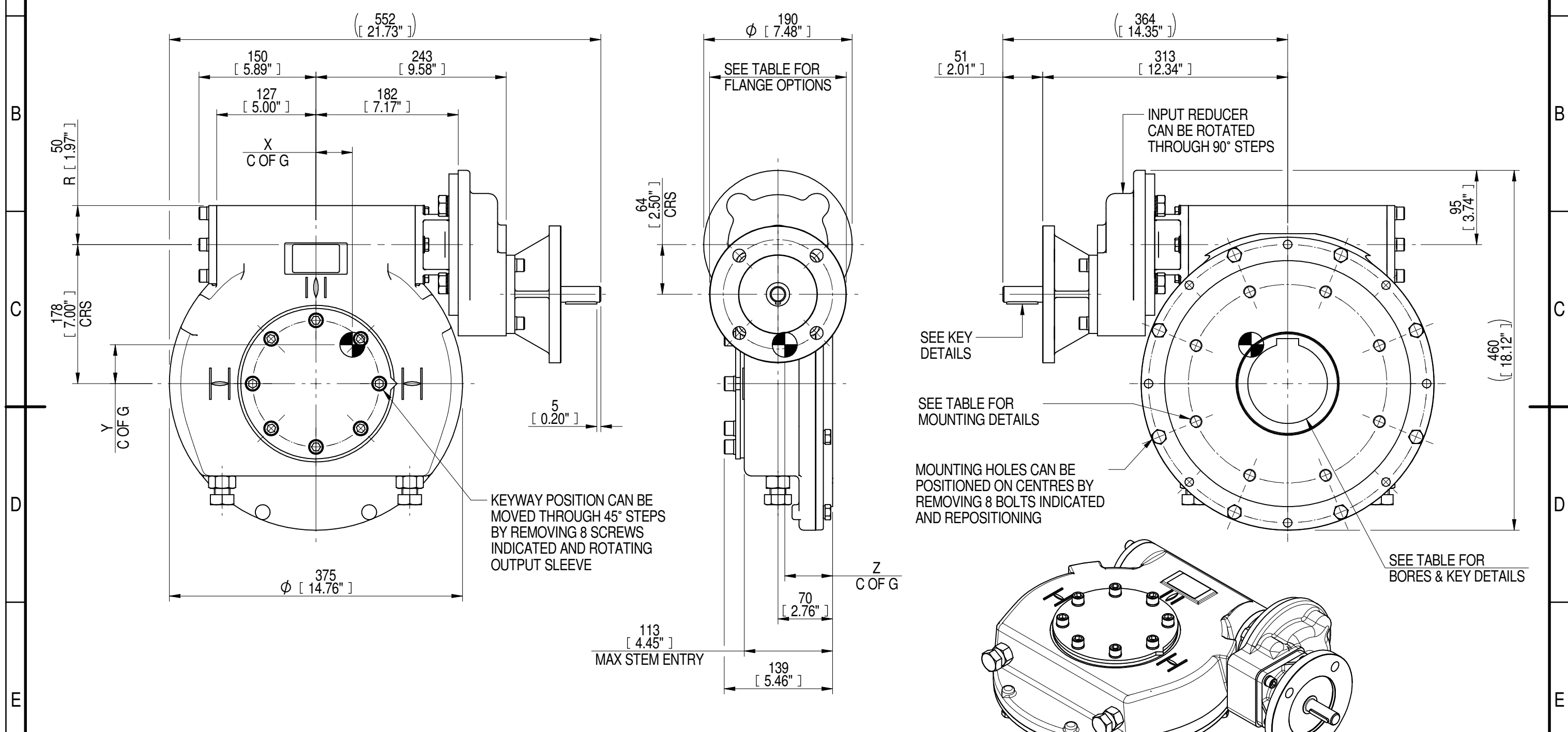

PLAN VIEW OF GEARBOX IN CLOSED POSITION SHOWING STANDARD KEYWAY POSITIONS. ALTERNATIVES AVAILABLE ON REQUEST

- NOTES:
1. * THREAD DEPTH DOES NOT MATCH ISO STANDARD
2. CENTRE OF GRAVITY POSITION IS INDICATIVE FOR STANDARD BUILD WHEN IN POSITION SHOWN

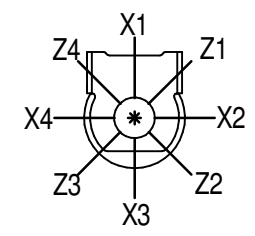

RATIO	TURNS TO CLOSE	M.A.±10%	WEIGHT (Kg)	MAX OUTPUT (Nm)	MAX INPUT (Nm)	X	Y	Z
280	70	88	72	11000	125	48	51	61
210	53	66	72	11000	167	47	50	61
140	35	44	71	11000	250	47	50	61
DESCRIPTION				TORQUE		CENTRE OF GRAVITY		

AS PART OF CONTINUOUS PRODUCT DEVELOPMENT, ALL DETAILS SUBJECT TO CHANGE WITHOUT PRIOR NOTICE. FOR UP TO DATE DETAILS PLEASE VISIT www.rotork.com

<p>LEEDS - UK www.rotork.com</p>	<p>This drawing is confidential and is the property of Rotork Gears and must not be reproduced either wholly or partly. All rights in respect of patents, designs and copyrights are reserved. ©2016</p>	<p>Document Type PUBLICITY</p> <p>Dimensions in mm</p>	<p>Title IW/MOW63 QUARTER TURN GEARBOX, 140/210/280 : 1, F14/ FA14 INPUT : F25/ FA25 OUTPUT</p>
			<p>Drawing Number PUB-IW63FBIRS-F14-F25</p>
<p>Sheet 1 of 1 Size A3</p>		<p>Iss. 01</p>	