

INPUT FLANGE DETAILS		MOUNTING HOLES - BOLT CIRCLE (OFF CENTRES)				STEM ACCEPTANCE IN ACCORDANCE TO STANDARD											
INPUT FLANGE	FLANGE O/DIA.	SHAFT DIA.	RECESS DIA.	RECESS DEPTH	HOLE DETAILS (OFF CENTRES)	KEY DETAILS	ISO 5211 / MSS SP-101 MOUNTING OPTION	HOLE DETAILS (OFF CENTRES)	MAX OUTSIDE DIA. INCLUDING DRILLED HOLES	MIN INSIDE DIA. INCLUDING DRILLED HOLES	SQ BORE MAX	STANDARD	MIN BORE	SQ KEY MAX BORE	SQ KEY SIZE	RECT. KEY MAX BORE	RECT KEY SIZE
ISO F10	Ø125 x 10 (Ø4.92" x 0.393")	Ø20.00-0.05 (Ø0.787"-0.002")	Ø70.05+0.15 (Ø2.758"+0.006")	4 (0.16")	4 x Ø10.5 ON Ø102.0 P.C. (4 x Ø0.41" ON Ø4.02" P.C.)	6x6x40 (0.24"x0.24"x1.57")	ISO F16*	4 x M20 x 20 (0.79") DEEP ON Ø165.0 (Ø6.50") P.C.	Ø294 (11.57")	Ø156 (6.14")	□ 83.3 (3.28")	BS4235	-	-	-	102	28 x 16
FA10			4 x 3/4" UNC x 19 (0.75") DEEP ON Ø165.0 (Ø6.50") P.C.				ANSI B17.1	-				3.625"	1" SQ.	3.75"	1" x 3/4"		
			Ø58.70+0.15 (Ø2.311"+0.006")				FA16*					DIN 6885	-	-	-	102	28 x 16

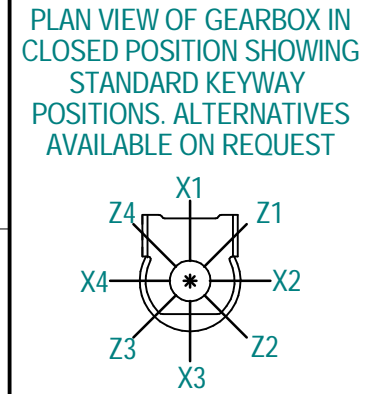
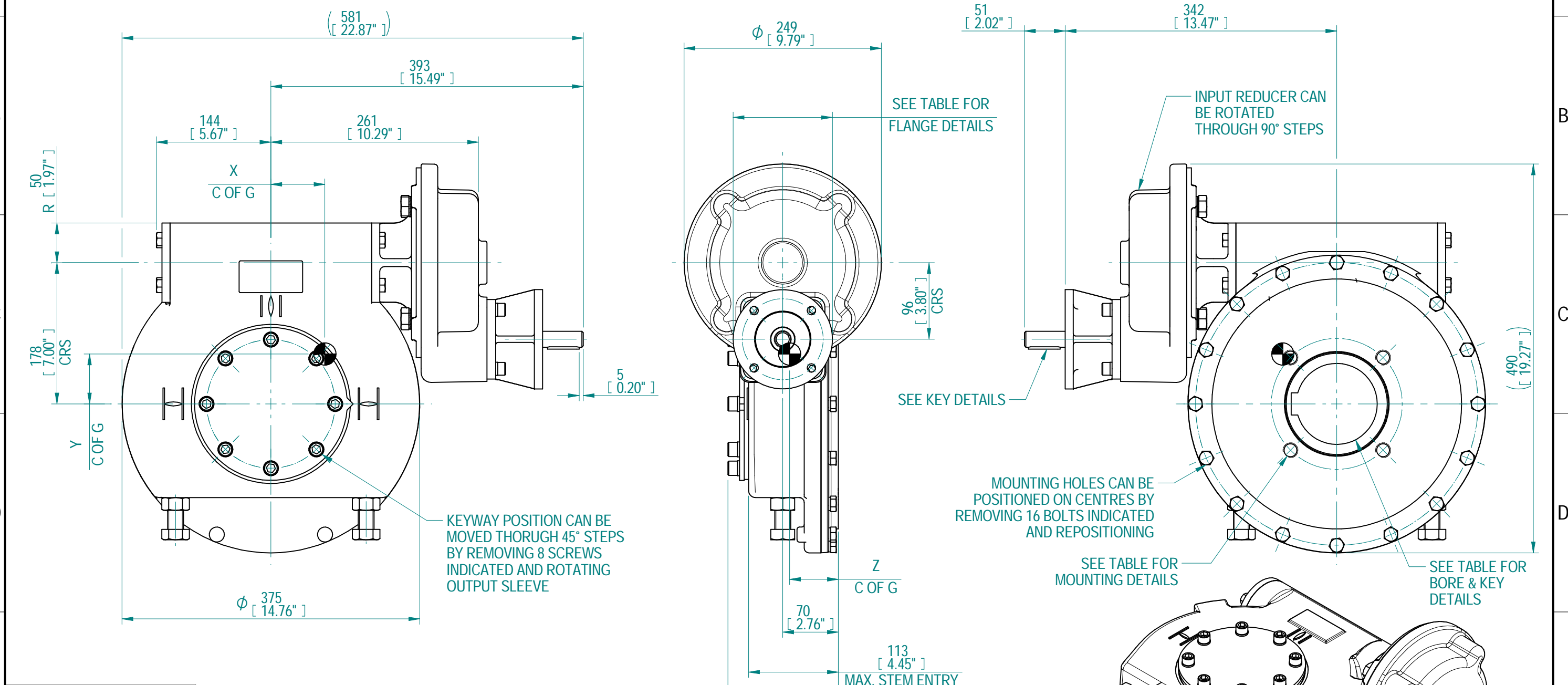

- NOTES:
- OTHER INPUT AND OUTPUT OPTIONS AVAILABLE - SEE 'IW GEARBOX BROCHURE' AT WWW.ROTORK.COM FOR FURTHER DETAILS.
 - CENTRE OF GRAVITY POSITION IS INDICATIVE FOR STANDARD BUILD WHEN IN POSITION SHOWN.
 - * THREAD DEPTH DOES NOT MATCH ISO STANDARD.
 - WEIGHT AND C OF G DIMENSIONS WILL VARY +/-1% DEPENDING ON RATIO.

RATIO	456	114	145	85	9924	68	68	63	61
	385	96	122			81			

Rev	ECN	Revised	Rev. Approved	Date	Change Description
1-0	EC1603	S.Bailey	C.Flesher	2021-04-28	Endcap and Flange fasteners changed from Durlok to Hex Head

AS PART OF CONTINUOUS PRODUCT DEVELOPMENT, ALL DETAILS SUBJECT TO CHANGE WITHOUT PRIOR NOTICE. FOR UP TO DATE DETAILS PLEASE VISIT www.rotork.com

rotork Gears
Leeds - UK
www.rotork.com

© 2020 Rotork Group of Companies. All rights reserved. This document and its contents may not be reproduced, distributed, transmitted, displayed, published, or broadcast, in whole, or in part, without the prior, express written permission of Rotork Group of Companies.

Dimensions in mm
Scale 1:5

Title **IW6 IR1L QUARTER TURN GEARBOX**

Created S.Monish 2019-09-24
Checked V.G.Balaji 2019-10-09
Approved J.Dickinson 2019-11-07

Drawing Number **PUB-IW6-IR1L**
Rev 1-0

Nominal Mass **SEE TABLE** Size A3 Sheet 1 of 1

Template Issue - 2018-05-10