

INPUT FLANGE DETAILS		MOUNTING HOLES - BOLT CIRCLE (OFF CENTRES)					STEM ACCEPTANCE IN ACCORDANCE TO STANDARD										
INPUT FLANGE	FLANGE O/DIA.	SHAFT DIA.	RECESS DIA.	RECESS DEPTH	HOLE DETAILS (OFF CENTRES)	KEY DETAILS	ISO 5211 / MSS SP-101 MOUNTING OPTION	HOLE DETAILS (OFF CENTRES)	MAX OUTSIDE DIA. INCLUDING DRILLED HOLES	MIN INSIDE DIA. INCLUDING DRILLED HOLES	SQ BORE MAX	STANDARD	MIN BORE	SQ KEY MAX BORE	SQ KEY SIZE	RECT. KEY MAX BORE	RECT KEY SIZE
ISO F10	Ø125 x 10 (Ø4.92" x 0.393")	Ø20.00-0.05 (Ø0.787"-0.002")	Ø70.05+0.15 (Ø2.758"+0.006")	4 (0.16")	4 x Ø10.5 ON Ø102.0 P.C. (4 x Ø0.41" ON Ø4.02" P.C.)	6x6x40 (0.24"x0.24"x1.57")	ISO F14*	4 x M16 x 20 (0.79") DEEP ON Ø140.0 (Ø5.51") P.C.	Ø198 (7.79")	Ø122 (4.80")	□ 62 (2.44")	BS4235	-	-	-	76	22 x 14
FA10			4 x 5/8" UNC x 20 (0.79") DEEP ON Ø139.7 (Ø5.50") P.C.				FA14*	4 x 5/8" UNC x 20 (0.79") DEEP ON Ø139.7 (Ø5.50") P.C.				ANSI B17.1	-	2.75"	3/4" SQ.	3"	3/4" x 1/2"
			Ø58.70+0.15 (Ø2.311"+0.006")									DIN 6885	-	-	-	76	22 x 14

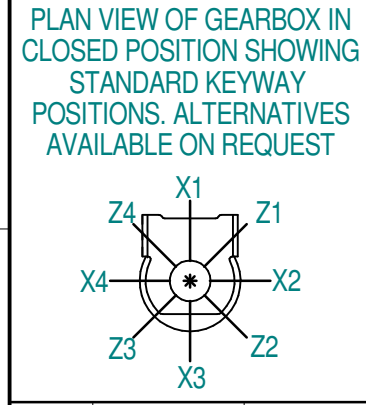
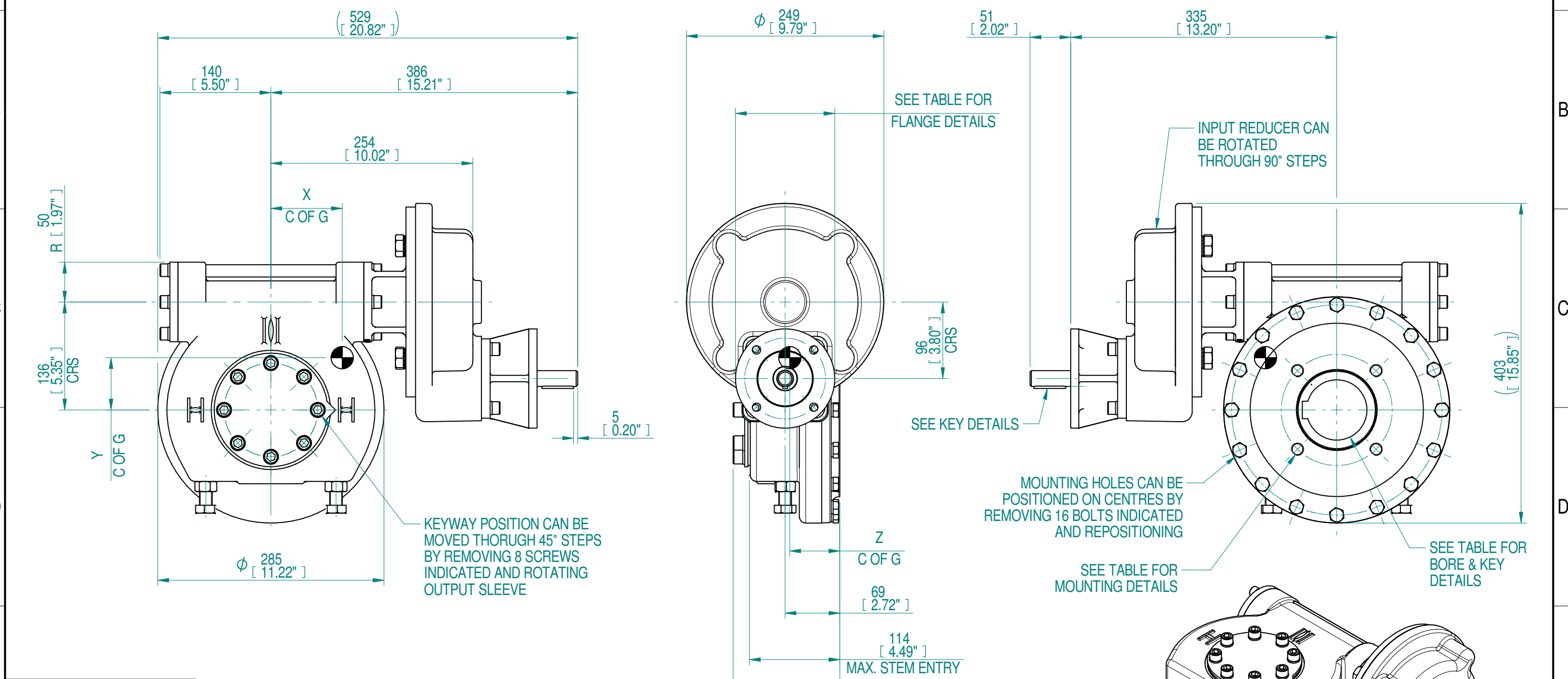

- NOTES:
- OTHER INPUT AND OUTPUT OPTIONS AVAILABLE - SEE 'IW GEARBOX BROCHURE' AT WWW.ROTORK.COM FOR FURTHER DETAILS.
 - CENTRE OF GRAVITY POSITION IS INDICATIVE FOR STANDARD BUILD WHEN IN POSITION SHOWN.
 - * THREAD DEPTH DOES NOT MATCH ISO STANDARD.
 - WEIGHT AND C OF G DIMENSIONS WILL VARY +/-1% DEPENDING ON RATIO.

RATIO	TURNS TO CLOSE	M.A. (±10%)	WEIGHT (KG)	MAX OUTPUT (Nm)	MAX INPUT (Nm)	X	Y	Z
288	72	91	63	8000	88	90	66	63
243	61	77			104			

Rev	ECN	Revised	Rev. Approved	Date	Change Description
0-1		J.Dickinson	J.Dickinson	2019-11-12	Include secondary units

AS PART OF CONTINUOUS PRODUCT DEVELOPMENT, ALL DETAILS SUBJECT TO CHANGE WITHOUT PRIOR NOTICE. FOR UP TO DATE DETAILS PLEASE VISIT www.rotork.com

rotork Gears
Leeds - UK
www.rotork.com

©2019 Rotork Group of Companies. All rights reserved. This document and its contents may not be reproduced, distributed, transmitted, displayed, published, or broadcast, in whole, or in part, without the prior, express written permission of Rotork Group of Companies.

Dimensions in mm
Scale 1:5

Title **IW56 IR1L QUARTER TURN GEARBOX**

Created S.Monish 2019-09-24
Checked V.G.Balaji 2019-09-27
Approved J.Dickinson 2019-11-08

Drawing Number **PUB-IW56-IR1L**
Rev 0-1

Nominal Mass **SEE TABLE** Size A3 Sheet 1 of 1