

1	2		3		4		5		6		7		8				
INPUT FLANGE DETAILS					MOUNTING HOLES - BOLT CIRCLE (OFF CENTRES)					STEM ACCEPTANCE IN ACCORDANCE TO STANDARD							
INPUT FLANGE	FLANGE O/DIA.	SHAFT DIA.	RECESS DIA.	RECESS DEPTH	HOLE DETAILS (OFF CENTRES)	KEY DETAILS	ISO 5211 / MSS SP-101 MOUNTING OPTION	HOLE DETAILS (OFF CENTRES)	MAX OUTSIDE DIA. INCLUDING DRILLED HOLES	MIN INSIDE DIA. INCLUDING DRILLED HOLES	SQ BORE MAX	STANDARD	MIN BORE	SQ KEY MAX BORE	SQ KEY SIZE	RECT. KEY MAX BORE	RECT KEY SIZE
ISO F25	Ø350 x 20 (Ø13.77" x 0.787")	Ø75.00-0.05 (Ø2.95"-0.002")	Ø200.10+0.10 (Ø7.878"+0.004")	5 (0.20")	8 x Ø16.5 ON Ø254.0 P.C. (8 x Ø0.65" ON Ø10.00" P.C.)	22x14x140 (0.86"x0.55"x5.51")	ISO F40*	8 x M36 x 36 (1.42") DEEP ON Ø406.0 (Ø15.98") P.C.	Ø835 (32.87")	Ø366 (14.40")	□ 180 (7.08")	BS4235	-	-	-	272	63 x 32
FA25			FA40*				8 x 1.25" UNC x 36 (1.42") DEEP ON Ø406.4 (Ø16.00") P.C.	ANSI B17.1				-	9.5"	2 1/2" SQ.	10.25"	2 1/2" x 1 3/4"	
			Ø152.30+0.17 (Ø5.996"+0.007")									DIN 6885	-	-	-	272	63 x 32

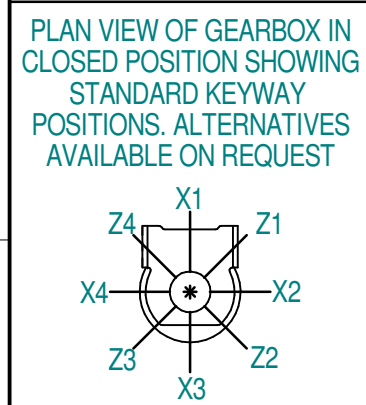
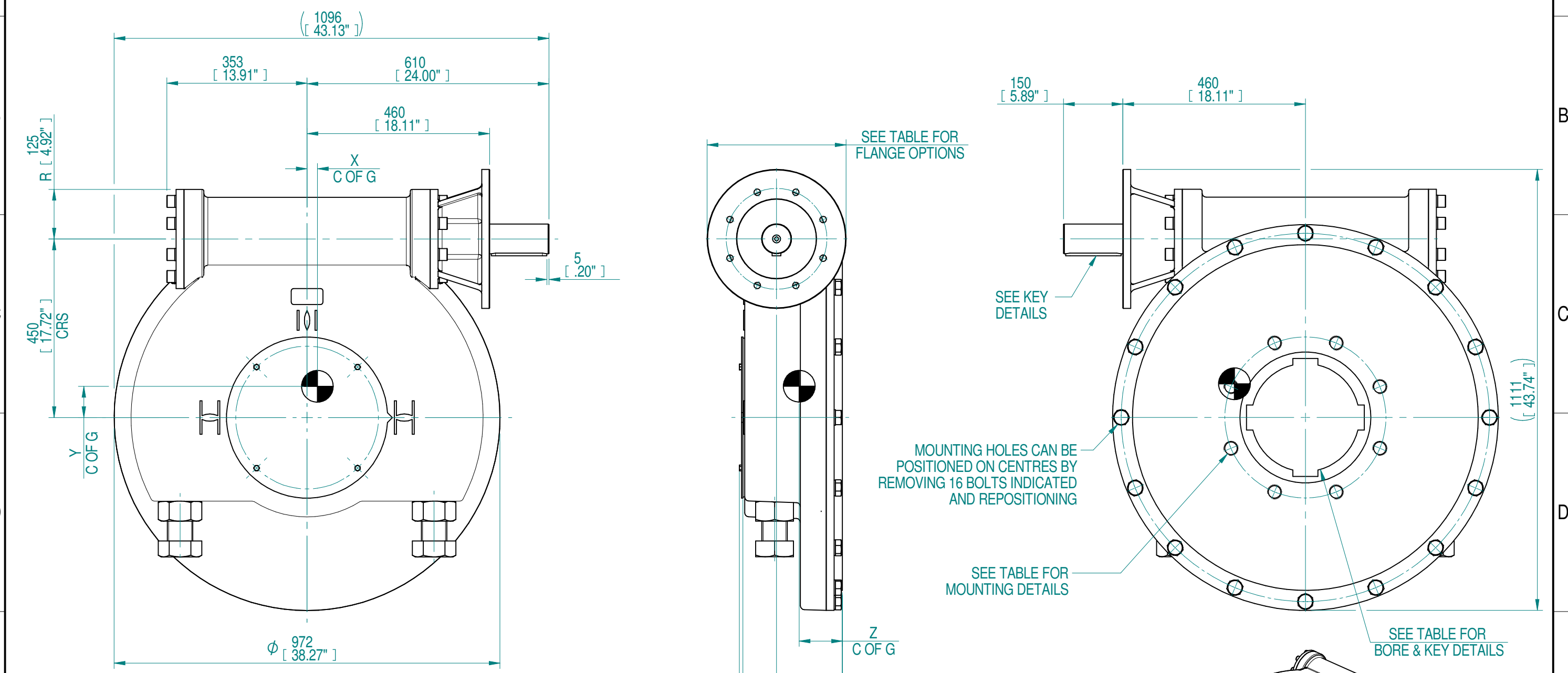

- NOTES:
- OTHER INPUT AND OUTPUT OPTIONS AVAILABLE - SEE 'IW GEARBOX BROCHURE' AT [WWW.ROTORK.COM](http://WWW.ROTORK.COM) FOR FURTHER DETAILS.
  - CENTRE OF GRAVITY POSITION IS INDICATIVE FOR STANDARD BUILD WHEN IN POSITION SHOWN.
  - \* THREAD DEPTH DOES NOT MATCH ISO STANDARD.
  - WEIGHT AND C OF G DIMENSIONS WILL VARY +/-1% DEPENDING ON RATIO.

70	18	27	868	180000	6561	26	79	109
RATIO	TURNS TO CLOSE	M.A. ± 10%	WEIGHT (KG)	MAX OUTPUT (Nm)	MAX INPUT (Nm)	X	Y	Z
DESCRIPTION						CENTRE OF GRAVITY		

0-0		S.Monish	J.Dickinson	2019-11-12	First issue			
Rev	ECN	Revised	Rev. Approved	Date	Change Description			

AS PART OF CONTINUOUS PRODUCT DEVELOPMENT, ALL DETAILS SUBJECT TO CHANGE WITHOUT PRIOR NOTICE. FOR UP TO DATE DETAILS PLEASE VISIT [www.rotork.com](http://www.rotork.com)

**rotork** Gears  
LEEDS - UK  
[www.rotork.com](http://www.rotork.com)

©2019 Rotork Group of Companies. All rights reserved. This document and its contents may not be reproduced, distributed, transmitted, displayed, published, or broadcast, in whole, or in part, without the prior, express written permission of Rotork Group of Companies.

Dimensions in mm  
Scale 1:10

Title **IW126 N QUARTER TURN GEARBOX 10" BORE BASIC RATIO**

Created S.Monish 2019-10-15  
Checked V.G.Balaji 2019-10-15  
Approved J.Dickinson 2019-11-12

Drawing Number **PUB-IW126-N-1**  
Rev 0-0

Nominal Mass **SEE TABLE** Size A3 Sheet 1 of 1

Template Issue - 2018-05-10