

1	2		3		4		5		6			7		8	
INPUT FLANGE DETAILS							MOUNTING HOLES - BOLT CIRCLE (OFF CENTRES)								
INPUT FLANGE	FLANGE O/DIA. + THICKNESS	SHAFT DIA.	RECESS DIA.	RECESS DEPTH	HOLE DETAILS (OFF CENTRES)	KEY DETAILS	ISO 5211 / MSS SP-101 MOUNTING OPTION	HOLE DETAILS (22.5° OFF CENTRES)	STANDARD	MIN BORE	SQ KEY MAX BORE	SQ KEY SIZE	RECT. KEY MAX BORE	RECT. KEY SIZE	SQ BORE MAX
-	-	Ø50.00-0.05 (Ø1.969"-0.002")	-	-	-	14x9x55 (0.55"x0.35"x2.17")	ISO F35*	8 x M30 x 36 (1.42") DEEP ON Ø356.0 (Ø14.02") P.C.	BS4235	-	-	-	203	50 x 28	□ 152.6 (6.00")
-	-	-	-	-	-	-	FA35*	8 x 1" UNC x 36 (1.42") DEEP ON Ø355.6 (Ø14.00") P.C.	ANSI B17.1	-	7.375"	1.3/4" SQ.	7.625"	2" x 1.3/8"	
-	-	-	-	-	-	-	-	-	DIN 6885	-	-	-	203	50 x 28	

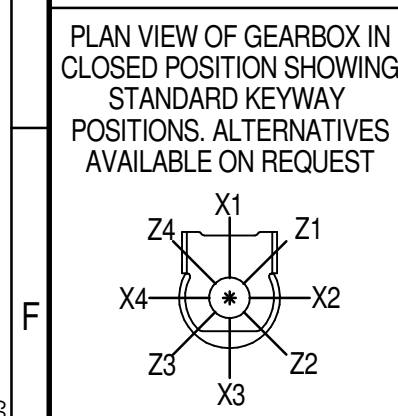
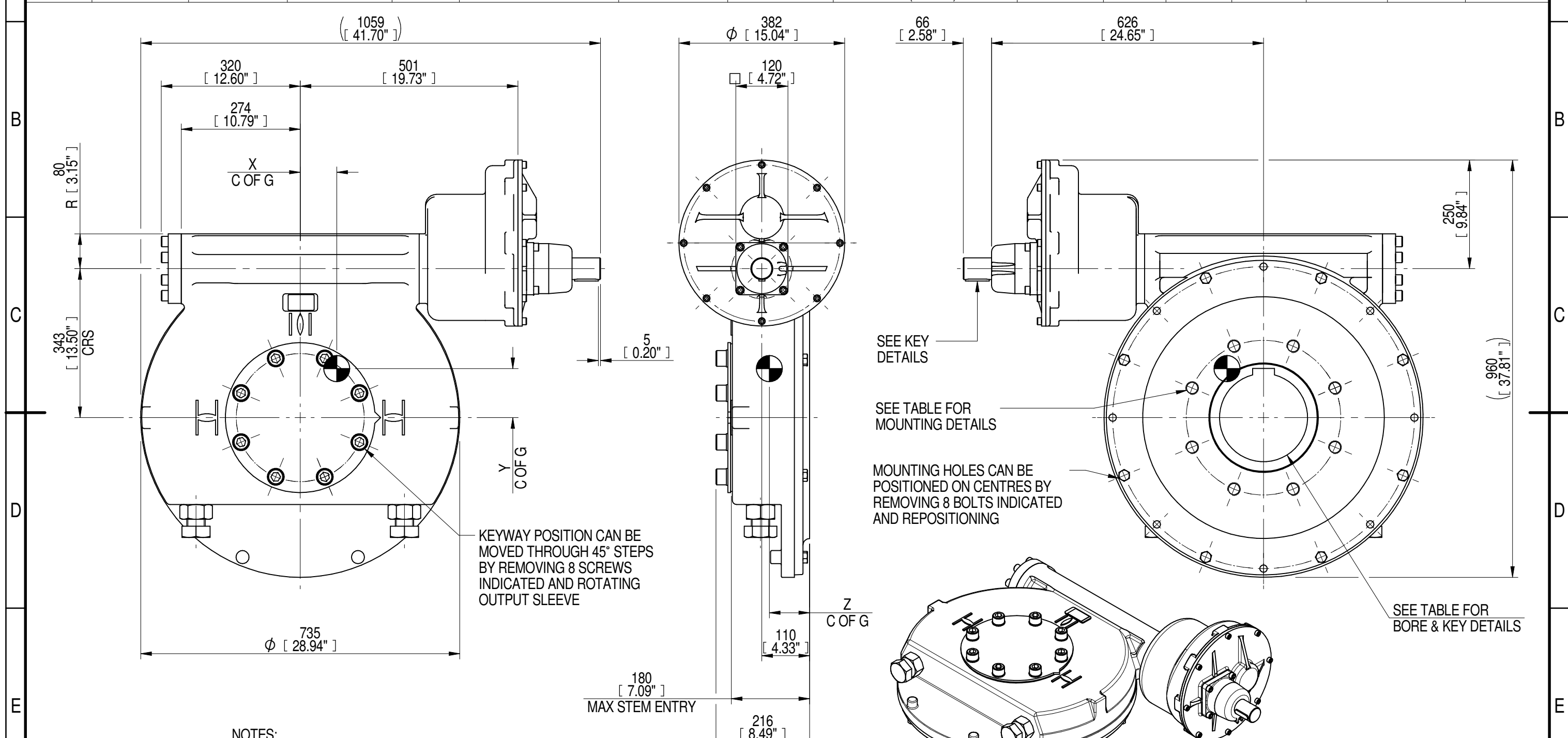

NOTES:
 1. * THREAD DEPTH DOES NOT MATCH ISO STANDARD
 2. CENTRE OF GRAVITY POSITION IS INDICATIVE FOR STANDARD BUILD WHEN IN POSITION SHOWN

RATIO	TURNS TO CLOSE	M.A. ± 10%	WEIGHT (Kg)	MAX OUTPUT (Nm)	MAX INPUT (Nm)	X	Y	Z
DESCRIPTION			TORQUE		CENTRE OF GRAVITY			
3000	750	1188	393	88130	74	84	112	93
2520	630	998	398	88130	88	89	117	93
2160	540	855	393	88130	103	83	112	93
1440	360	570	394	88130	155	84	113	93
1080	270	428	392	88130	206	82	112	93
960	240	380	394	88130	232	84	113	93

AS PART OF CONTINUOUS PRODUCT DEVELOPMENT, ALL DETAILS SUBJECT TO CHANGE WITHOUT PRIOR NOTICE. FOR UP TO DATE DETAILS PLEASE VISIT www.rotork.com

	Document Type PUBLICITY	Title IW/MOW10 QUARTER TURN GEARBOX, 960/1080/1440/2160/2520/3000 : 1, MANUAL INPUT: F35/ FA35 OUTPUT	Drawing Number PUB-IW10FBIR3-2-MAN-F35	Iss. 01
	Dimensions in mm			
LEEDS - UK www.rotork.com	This drawing is confidential and is the property of Rotork Gears and must not be reproduced either wholly or partly. All rights in respect of patents, designs and copyrights are reserved. ©2016			