

1	2		3		4		5		6			7		8	
INPUT FLANGE DETAILS							MOUNTING HOLES - BOLT CIRCLE (OFF CENTRES)								
INPUT FLANGE	FLANGE O/DIA. + THICKNESS	SHAFT DIA.	RECESS DIA.	RECESS DEPTH	HOLE DETAILS (22.5° OFF CENTRES)	KEY DETAILS	ISO 5211 / MSS SP-101 MOUNTING OPTION	HOLE DETAILS (22.5° OFF CENTRES)	STANDARD	MIN BORE	SQ KEY MAX BORE	SQ KEY SIZE	RECT. KEY MAX BORE	RECT. KEY SIZE	SQ BORE MAX
ISO F25	Ø300 x 20 (Ø11.81" x 0.787")	Ø50.00-0.05 (Ø1.969"-0.002")	Ø200.10+0.10 (Ø7.878"+0.004")	5 (0.20")	8 x Ø16.5 ON Ø254.0 P.C. (8 x Ø0.65" ON Ø10.00" P.C.)	14x9x55 (0.55"x0.35"x2.17")	ISO F40*	8 x M36 x 36 (1.42") DEEP ON Ø406.0 (Ø15.98") P.C.	BS4235 BS46	- -	- -	- -	203 7.625"	50 x 28 2" x 1.3/8"	□ 152.6 (6.00")
FA25			Ø152.30+0.17 (Ø5.996"+0.007")				FA40*	8 x 1.25" UNC x 36 (1.42") DEEP ON Ø406.4 (Ø16.00") P.C.	ANSI B17.1 DIN 6885	- -	7.375" -	1.3/4" SQ. -	7.625" 203	2" x 1.1/2" 50 x 28	

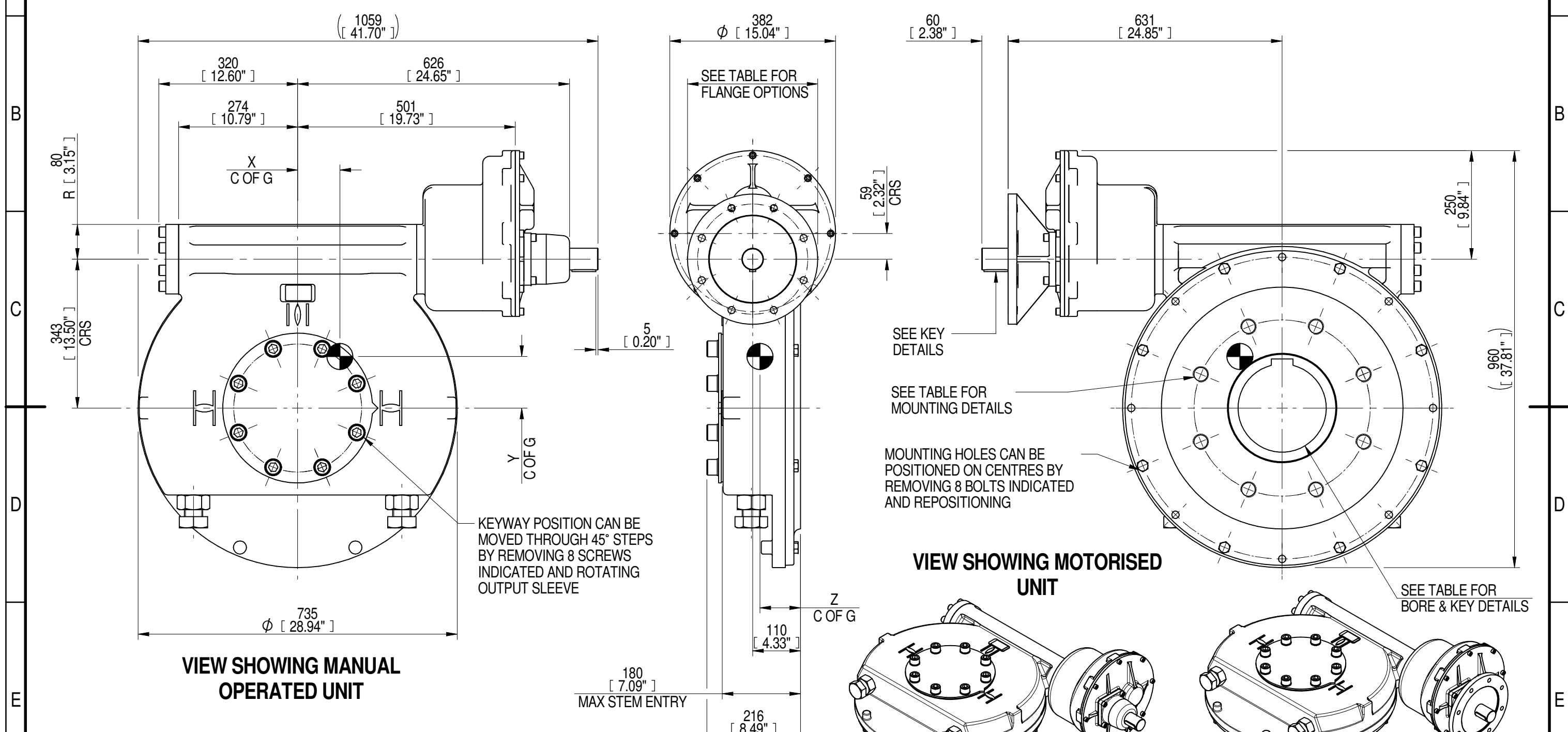

PLAN VIEW OF GEARBOX IN CLOSED POSITION SHOWING STANDARD KEYWAY POSITIONS. ALTERNATIVES AVAILABLE ON REQUEST



NOTES:  
 1. \* THREAD DEPTH DOES NOT MATCH ISO STANDARD  
 2. CENTRE OF GRAVITY POSITION IS INDICATIVE FOR STANDARD BUILD WHEN IN POSITION SHOWN

RATIO	URNS TO CLOSE	M.A. ± 10%	WEIGHT (Kg)	MAX OUTPUT (Nm)	MAX INPUT (Nm)	X	Y	Z
720	180	285	404	65078	228	97	119	93
540	135	214	402	65078	304	96	118	93
360	90	142	404	65078	458	98	119	93
240	60	95	406	65078	685	99	120	93
180	45	71	403	65078	917	97	119	93
DESCRIPTION			TORQUE			CENTRE OF GRAVITY		

AS PART OF CONTINUOUS PRODUCT DEVELOPMENT, ALL DETAILS SUBJECT TO CHANGE WITHOUT PRIOR NOTICE. FOR UP TO DATE DETAILS PLEASE VISIT [www.rotork.com](http://www.rotork.com)

**rotork** Gears  
 LEEDS - UK  
[www.rotork.com](http://www.rotork.com)

This drawing is confidential and is the property of Rotork Gears and must not be reproduced either wholly or partly. All rights in respect of patents, designs and copyrights are reserved. ©2016

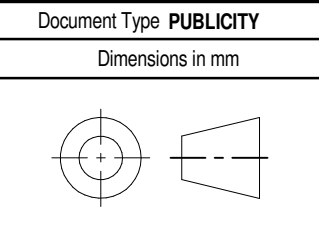

Title <b>IW/MOW10 QUARTER TURN GEARBOX, 180/240/360/540/720 : 1, MANUAL, F25/FA25 INPUT: F40/ FA40 OUTPUT</b>		Iss. 01
Drawing Number <b>PUB-IW10FBIR3-1-F25-F40</b>		
Sheet 1 of 1	Size A3	