

1	2		3		4		5		6				7		8
INPUT FLANGE DETAILS							MOUNTING HOLES - BOLT CIRCLE (OFF CENTRES)								
INPUT FLANGE	FLANGE O/DIA. + THICKNESS	SHAFT DIA.	RECESS DIA.	RECESS DEPTH	HOLE DETAILS (45° OFF CENTRES)	KEY DETAILS	ISO 5211 / MSS SP-101 MOUNTING OPTION	HOLE DETAILS (22.5° OFF CENTRES)	STANDARD	MIN BORE	SQ KEY MAX BORE	SQ KEY SIZE	RECT. KEY MAX BORE	RECT. KEY SIZE	SQ BORE MAX
ISO F10	Ø125 x 15 (Ø4.92" x 0.59")	Ø20.00-0.05 (Ø0.787"-0.002")	Ø70.05+0.15 (Ø2.758"+0.006")	4 (0.16")	4 x Ø10.5 ON Ø102.0 P.C. (4 x Ø0.41" ON Ø4.02" P.C.)	6x6x40 (0.24"x0.24"x1.57")	ISO F40*	8 x M36 x 36 (1.42") DEEP ON Ø406.0 (Ø15.98") P.C.	BS4235	-	-	-	203	50 x 28	□ 152.6 (6.00")
FA10			Ø58.70+0.15 (Ø2.311"+0.006")				FA40*	8 x 1.25" UNC x 36 (1.42") DEEP ON Ø406.4 (Ø16.00") P.C.	ANSI B17.1	-	7.375"	1.3/4" SQ.	7.625"	2" x 1.1/2"	
								DIN 6885	-	-	-	-	203	50 x 28	

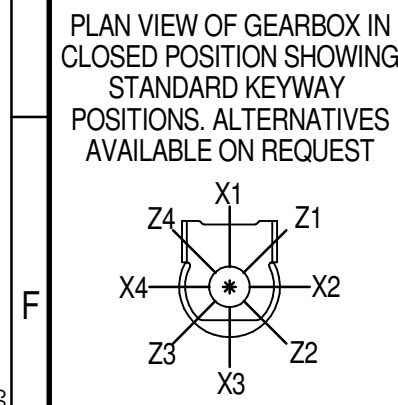
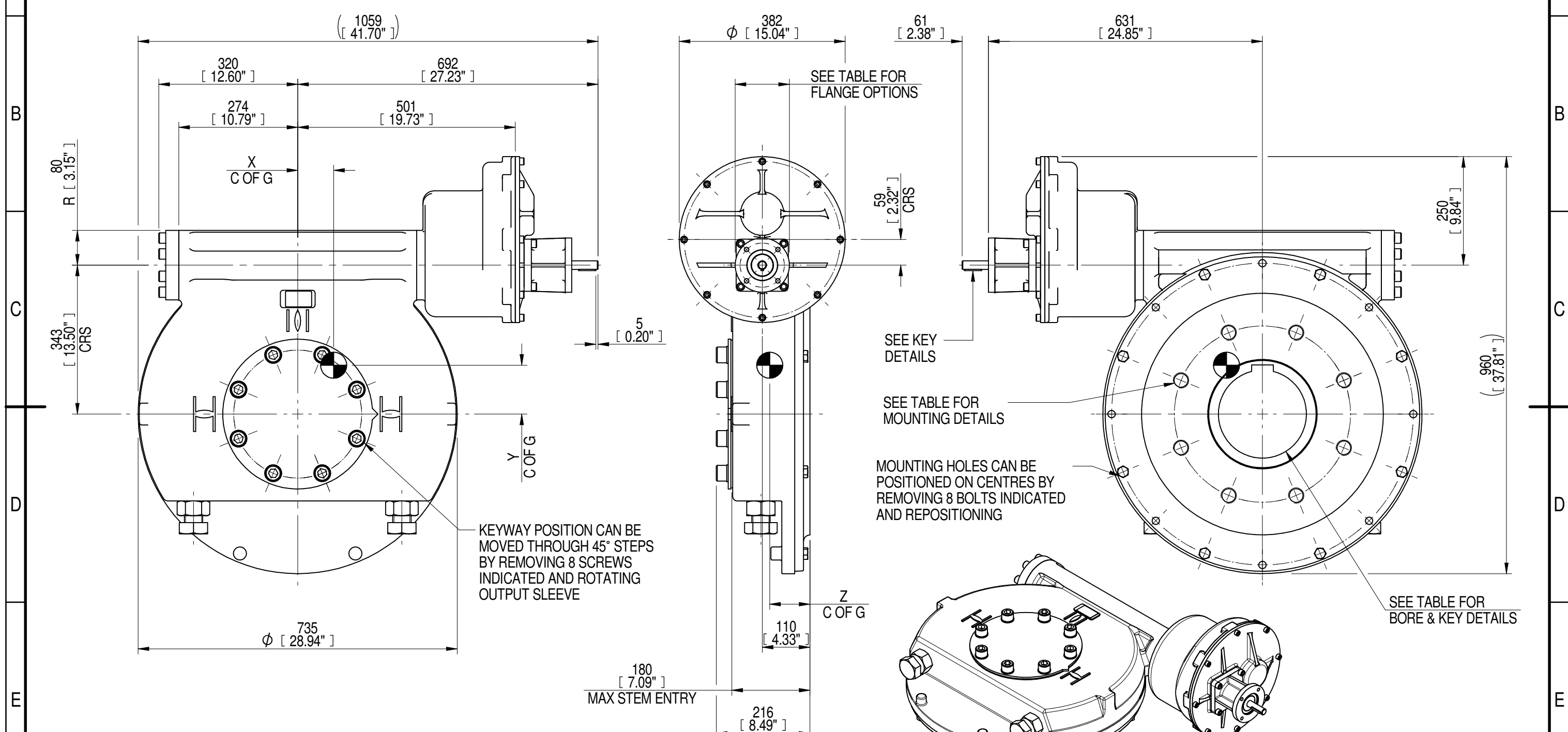

NOTES:
 1. * THREAD DEPTH DOES NOT MATCH ISO STANDARD
 2. CENTRE OF GRAVITY POSITION IS INDICATIVE FOR STANDARD BUILD WHEN IN POSITION SHOWN

RATIO	TURNS TO CLOSE	M.A. ± 10%	WEIGHT (Kg)	MAX OUTPUT (Nm)	MAX INPUT (Nm)	X	Y	Z
720	180	285	393	65078	228	83	113	93
540	135	214	391	65078	304	81	111	93
360	90	142	393	65078	458	84	112	93
240	60	95	395	65078	685	85	114	93
180	45	71	393	65078	917	83	113	93
DESCRIPTION			TORQUE			CENTRE OF GRAVITY		

AS PART OF CONTINUOUS PRODUCT DEVELOPMENT, ALL DETAILS SUBJECT TO CHANGE WITHOUT PRIOR NOTICE. FOR UP TO DATE DETAILS PLEASE VISIT www.rotork.com

rotork Gears
 LEEDS - UK
www.rotork.com

This drawing is confidential and is the property of Rotork Gears and must not be reproduced either wholly or partly. All rights in respect of patents, designs and copyrights are reserved. ©2016

Document Type **PUBLICITY**
 Dimensions in mm

Title
IW/MOW10 QUARTER TURN GEARBOX, 180/240/360/540/720 : 1, F10/ FA10 INPUT: F40/ FA40 OUTPUT

Drawing Number
PUB-IW10FBIR3-1-F10-F40

Sheet 1 of 1 Size A3