

INPUT FLANGE DETAILS					MOUNTING HOLES - BOLT CIRCLE (OFF CENTRES)				STEM ACCEPTANCE IN ACCORDANCE TO STANDARD							
INPUT FLANGE	FLANGE O/DIA. + THICKNESS	SHAFT DIA.	RECESS DIA.	RECESS DEPTH	HOLE DETAILS 22.5°(OFF CENTRES)	KEY DETAILS	ISO 5211 / MSS SP-101 MOUNTING OPTION	HOLE DETAILS 9° (OFF CENTRES)	MAX STEM SCREW ACCEPTANCE	STANDARD	MIN BORE	SQ KEY MAX BORE	SQ KEY SIZE	RECT. KEY MAX BORE	RECT KEY SIZE	SQ BORE MAX
F30	Ø350 x 20	Ø50.00 - 0.05	Ø230.10 + 0.05	6	8 HOLES Ø20.5 ON Ø298.0 P.C.	14x9x80	F60	20 HOLES M36x54 DEEP ON Ø603.0 P.C.	Ø225	BS4235 BS46	107.1 4.217"	- 7.500"	- 1.875"	206.0 7.750"	50 x 28 2" x 1.375"	□ 166 AF □ 6.535" AF
FA30	(Ø13.78" x 0.79")	(Ø1.969" - 0.002")	(Ø7.000" + 0.002")	(0.24")	8 HOLES (Ø0.81") ON (Ø11.73") P.C.	(0.55"x0.35"x3.15")	FA60	20 HOLES (1.25"UNCx2.13") DEEP ON (Ø23.74") P.C.	(Ø8.750")	ANSI B17.1 DIN 6885	4.217" 107.1	7.500" -	1.750" -	7.750" 206.0	2" x 1.50" 50 x 28	□ 6.535" AF □ 166 AF

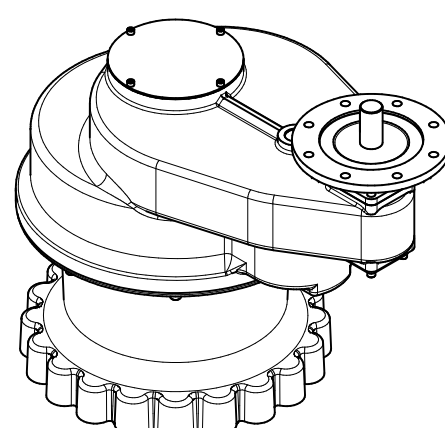

PLAN VIEW OF GEARBOX IN CLOSED POSITION SHOWING STANDARD KEYWAY POSITIONS. ALTERNATIVES AVAILABLE ON REQUEST

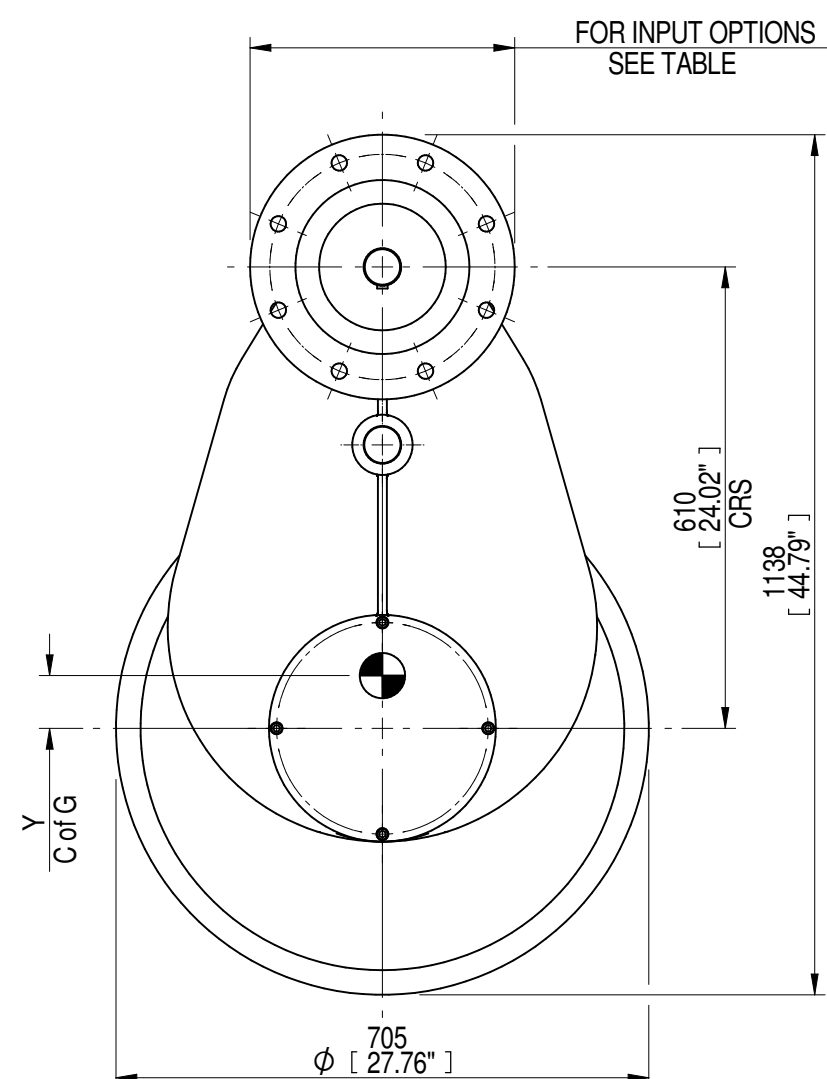
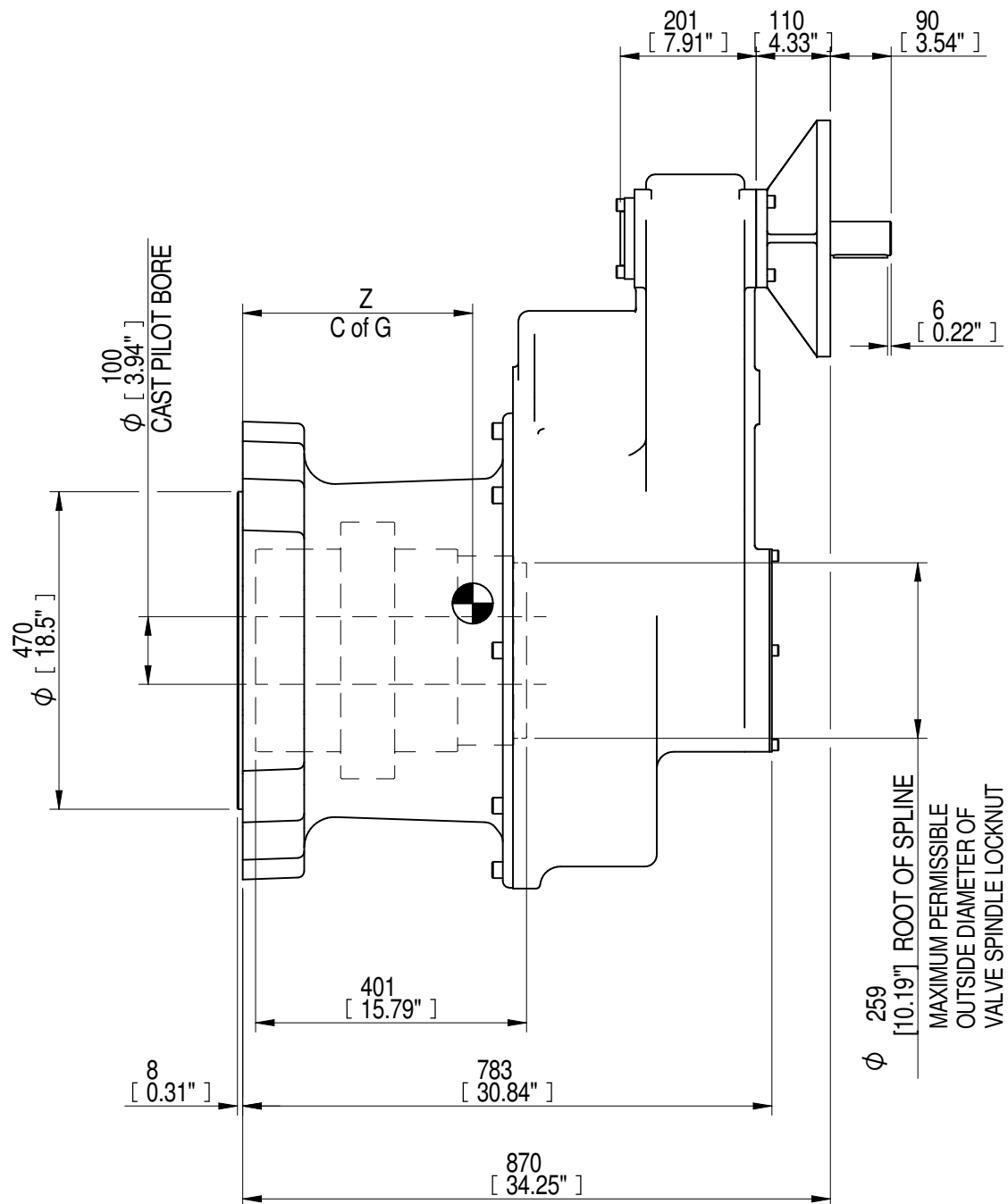
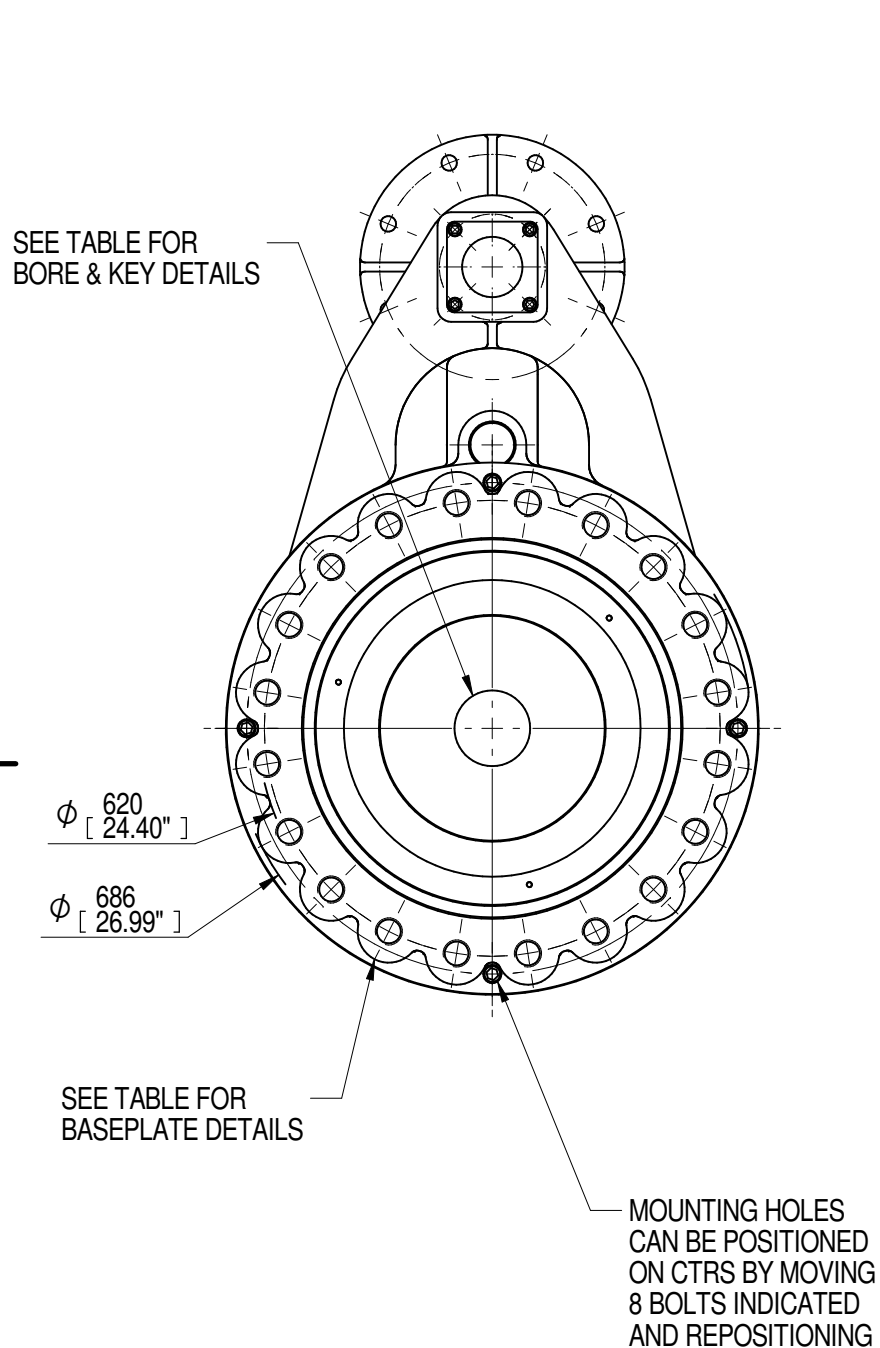
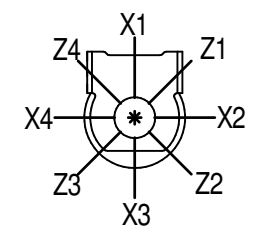

DESCRIPTION			TORQUE		CENTRE OF GRAVITY		
RATIO	M.A.	WEIGHT	MAX OUTPUT	MAX INPUT	X	Y	Z
15	13.650	1020 Kg	43386	3178	0	70	340
24	21.680	1017 Kg	43386	2001	0	68	340

AS PART OF CONTINUOUS PRODUCT DEVELOPMENT, ALL DETAILS SUBJECT TO CHANGE WITHOUT PRIOR NOTICE. FOR UP TO DATE DETAILS PLEASE VISIT www.rotork.com

 Leeds - UK www.rotork.com	This drawing is confidential and is the property of Rotork Gears and must not be reproduced either wholly or partly. All rights in respect of patents, designs and copyrights are reserved. © 2014		Document type PUBLICITY	Title IS21 GEARBOX F30/FA30 INPUT F60/FA60 OUTPUT	
	Created E CHANG 02/01/2014 Checked M JONES 15/01/2014 Approved		Dimensions in mm Scale 1:10		Drawing Number PUBIS21-F30-F60
			Sheet 1 of 1	Size A3	Rev B