

- NOTES**
- FOUR BASE OPTIONS ARE DETAILED TO SUIT THE RELEVANT COUPLING ARRANGEMENT.
 - THE REQUIRED BASE FOR THE SIDE & END VIEWS SHOULD BE LOADED TO MTG POSITION INDICATED.
 - ** REMOVAL ALLOWANCE REQUIRED.

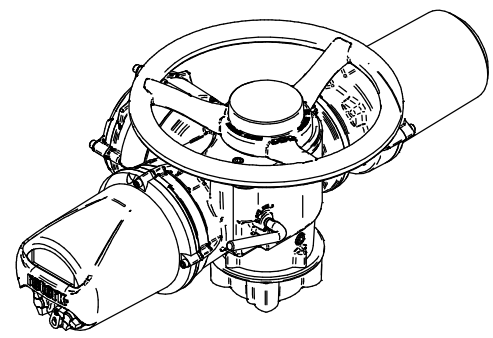

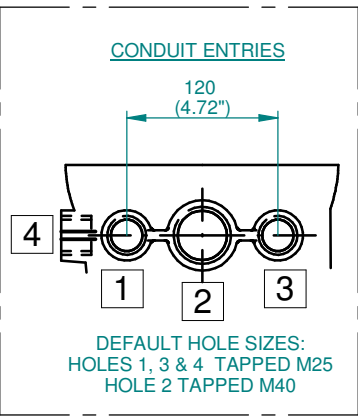

- NOTES**
- FOUR BASE OPTIONS ARE DETAILED TO SUIT THE RELEVANT COUPLING ARRANGEMENT.
 - THE REQUIRED BASE FOR THE SIDE & END VIEWS SHOULD BE LOADED TO MTG POSITION INDICATED.
 - ** REMOVAL ALLOWANCE REQUIRED.

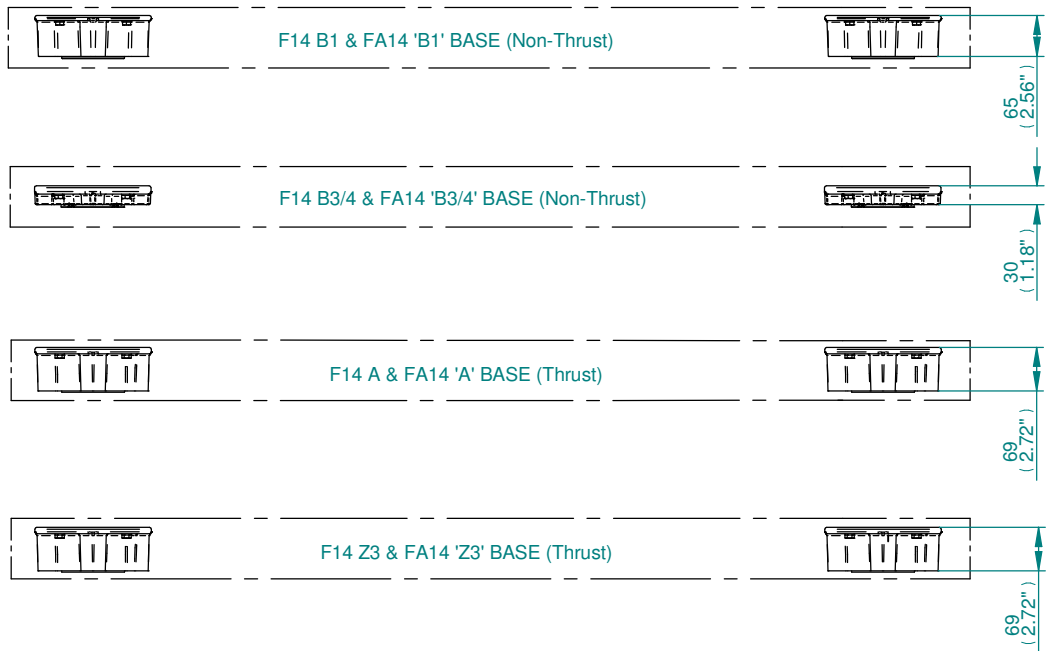
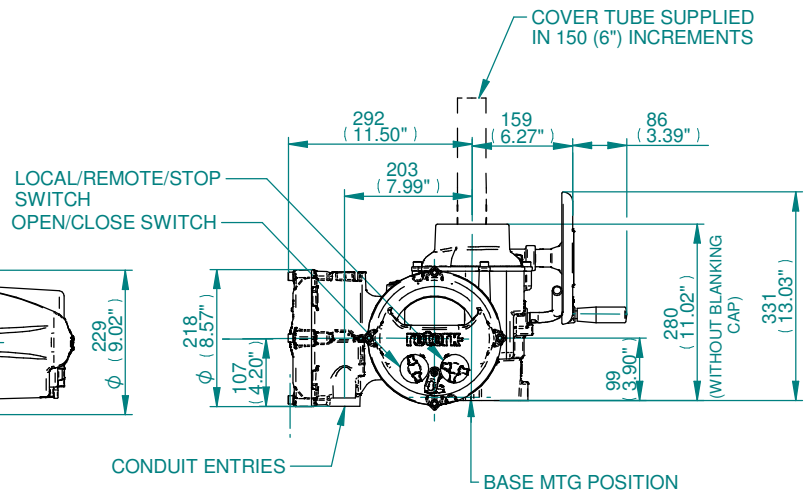
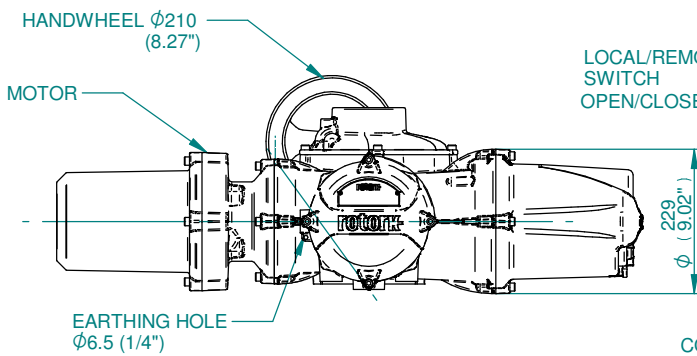
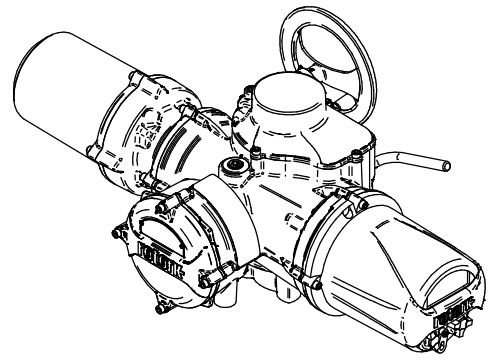
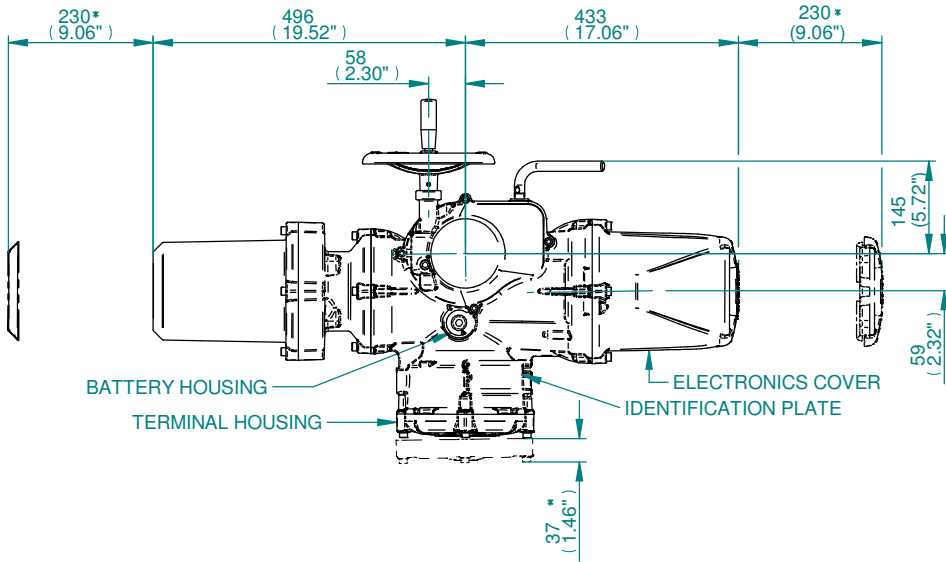
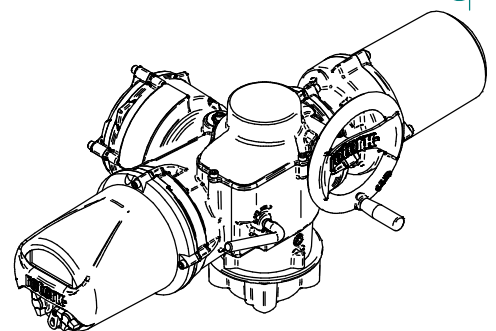

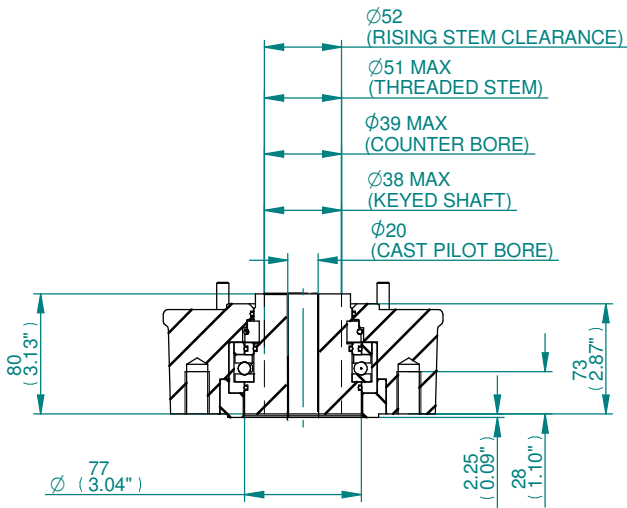

TYPICAL 'A' COUPLING DETAILS

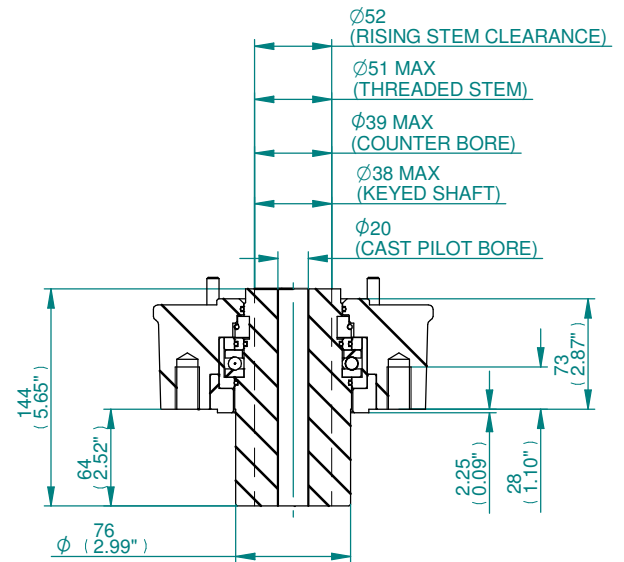

TYPICAL 'Z3' COUPLING DETAILS

NOTE : COUPLINGS WITHOUT PILOT BORE AVAILABLE IF SPECIFIED WITH ORDER.

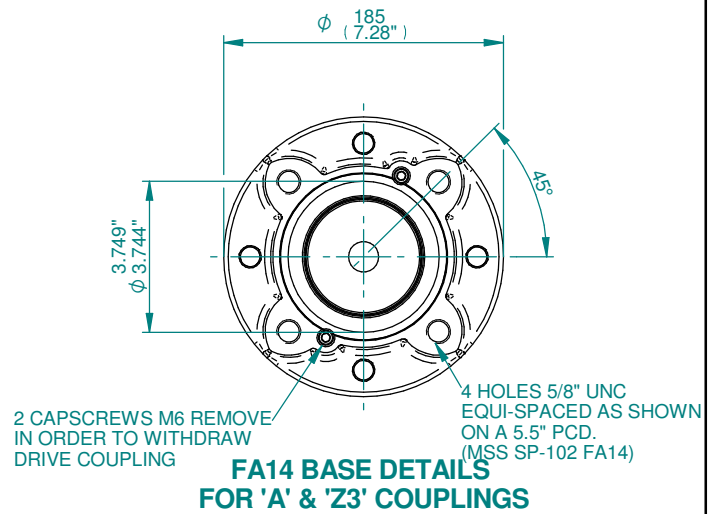
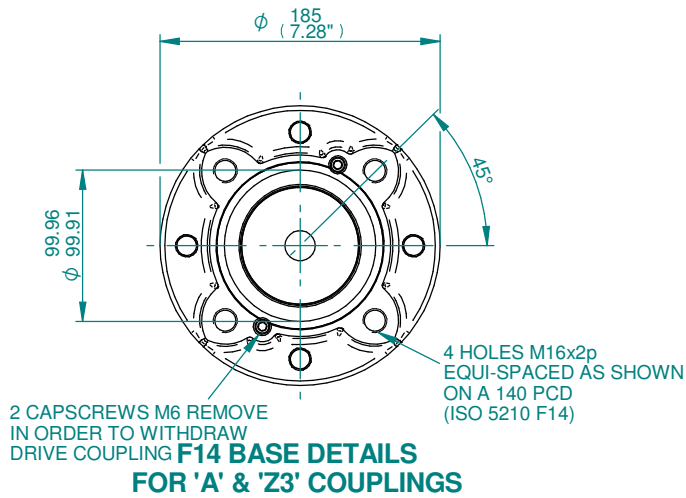

IQ3 SIZE 20-25 THRUST BASES

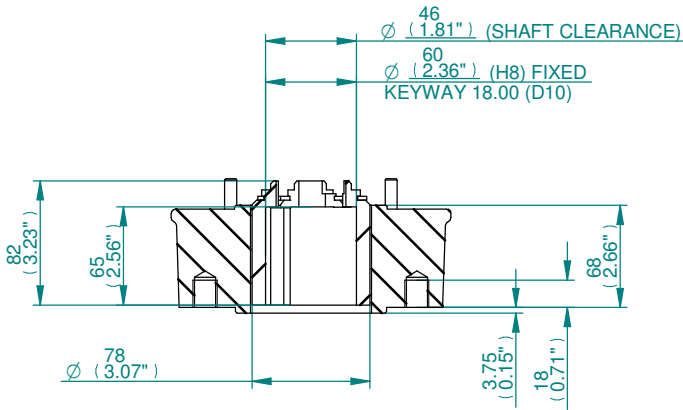

TYPICAL 'B1' COUPLING DETAILS

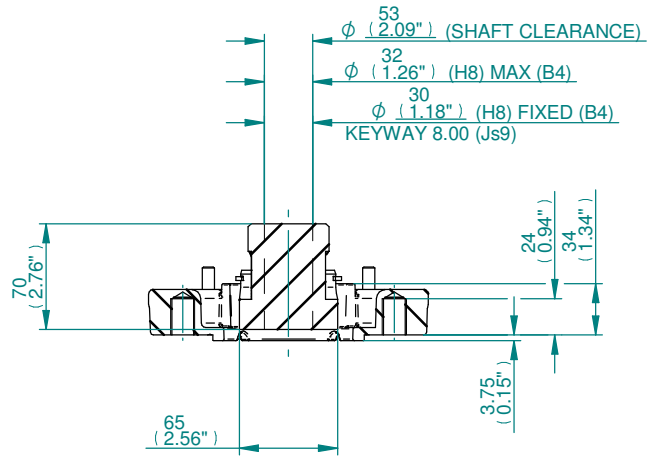

TYPICAL 'B3/B4' COUPLING DETAILS

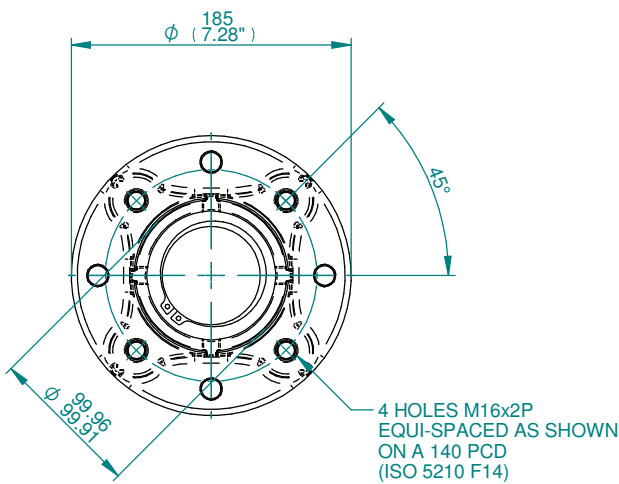

F14 BASE DETAILS FOR 'B1' & 'B3/B4' COUPLINGS

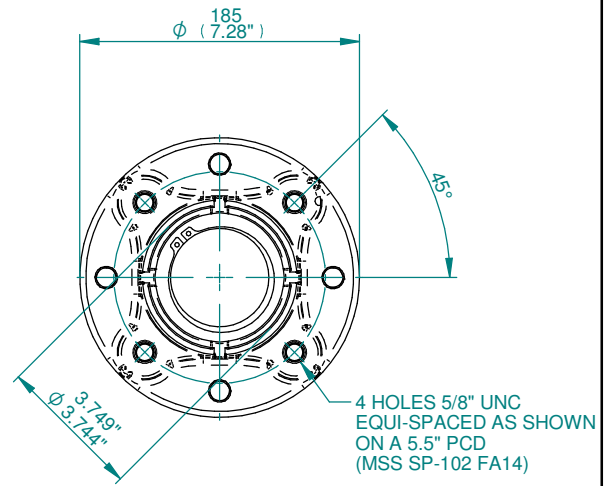

FA14 BASE DETAILS FOR 'B1' & 'B3/B4' COUPLINGS

**IQ3 SIZE 20-25
NON-THRUST BASES**